

Force

- » Peak: 312 - 780 N
- » Continuous: 51 - 102N

Maximum Velocity

- » Up to 5.9 m/s

Feedback

- » Built-in position sensor
- » 1V pk-pk sin/cos
- » 12 micron repeatability

Range of motion

- » 27~309 mm

Dimensions

- » W x H: 54 x 95mm
- » Rod diameter: 25mm

Applications

- » Packaging
- » Material Handling
- » Automated Assembly
- » Bio-medical

The OEM advantage

- » Reliable and cost-effective
- » Flexible position control
- » High speed and acceleration
- » Clean, quiet operation
- » No maintenance or adjustment

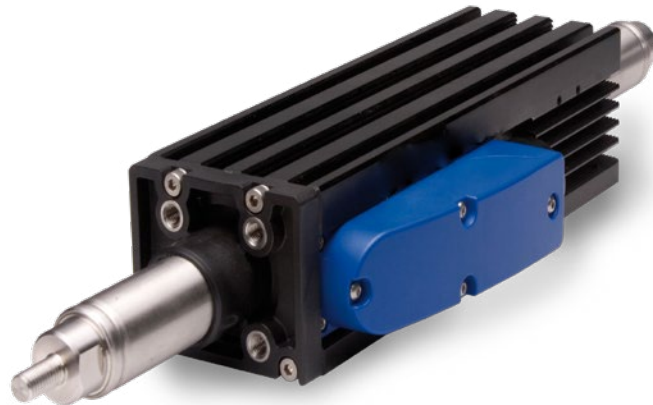

The ServoTube Actuator is an optimal solution for industrial position control. Faster than a ballscrew with the clean reliability of a linear forcer. ServoTube is a cost-effective alternative to air cylinders in applications requiring greater flexibility and control.

The ServoTube Actuator incorporates an IP67 rated forcer and a sealed stainless steel thrust rod enclosing rare-earth magnets. Four models deliver a continuous force range of 51~102 N (11~23 lb) with peak forces up to 780 N (175 lb). Twelve stroke lengths are available from 27~309 mm.

The magnetic design of ServoTube generates 12 micron (0.47 mil) repeatability and 350 micron (14 mil) accuracy from a non-contact, integral position sensor. No external encoder is required. Position output is industry standard 1V pk-pk sin/cos signals.

An internal dry bearing provides clean, quiet, maintenance-free performance. Life expectancy far exceeds typical ballscrew solutions.

The ServoTube Actuator is ideal for push/pull/lift material handling, packaging and automated assembly applications. ServoTube accepts a range of industry standard accessories for simple mechanical integration.

ELECTRICAL SPECIFICATIONS

FORCER TYPE	2504		2506		2508		2510		units
	S ⁽¹⁾	P ⁽¹⁾	S ⁽¹⁾	P ⁽¹⁾	S ⁽¹⁾	P ⁽¹⁾	S ⁽¹⁾	P ⁽¹⁾	
Peak force @ 25°C ambient for 1 sec	312	156	468	234	624	312	780	390	N
Peak current @ 25°C ambient for 1 sec	20		20		20		20		Apk
With 25 x 25 x2.5cm heatsink plate									
Continuous stall force @ 25°C ambient ⁽²⁾	51.2		69.5		86.4		102.4		N
Continuous stall current @ 25°C ambient	2.31	4.62	2.10	4.20	1.96	3.92	1.86	3.72	Arms
	3.27	6.54	2.97	5.94	2.77	5.54	2.62	5.24	Apk
Without heatsink plate									
Continuous stall force @ 25°C ambient ⁽²⁾	42.5		59.5		75.1		90.0		N
Continuous stall current @ 25°C ambient	1.92	3.84	1.80	3.60	1.70	3.40	1.63	3.26	Arms
	2.72	5.44	2.54	5.08	2.41	4.82	2.31	4.62	Apk
Force constant (sine commutation)	22.1	11.0	33.1	16.5	44.1	22.0	55.2	27.6	N/Arms
	15.6	7.8	23.4	11.7	31.2	15.6	39.0	19.5	N/Apk
Back EMF constant (phase to phase)	18.0	9.0	27.0	13.5	36.0	18.0	45.0	22.5	Vpk/m/s
Fundamental forcer constant	6.47		7.92		9.13		10.24		N/√W
Eddy current loss	9.51		12.55		15.58		18.61		N/m/s
Resistance @ 25°C (phase to phase)	6.02	1.50	9.02	2.25	12.03	3.01	15.04	3.76	Ohm
Resistance @ 100°C (phase to phase)	7.75	1.94	11.63	2.91	15.51	3.88	19.39	4.85	Ohm
Inductance @ 1kHz (phase to phase)	3.90	0.97	5.85	1.46	7.80	1.95	9.75	2.44	mH
Electrical time constant	0.65		0.65		0.65		0.65		ms
Maximum working voltage	380		380		380		380		V d.c.
Pole pitch (one electrical cycle)	51.2		51.2		51.2		51.2		mm
Peak acceleration ⁽³⁾	394	197	483	241	542	271	586	293	m/s ²
Maximum speed ⁽⁴⁾	5.9	4.4	5.3	5.1	4.7	5.6	4.2	5.8	m/s

Notes:

⁽¹⁾ S=series forcer phases, P=parallel forcer phases

⁽²⁾ Reduce continuous stall force to 89% at 40°C ambient

⁽³⁾ Based on a moving thrust rod with 27mm stroke and no payload

⁽⁴⁾ Based on a moving thrust rod with triangular move over maximum stroke and no payload

THERMAL SPECIFICATIONS

FORCER TYPE	2504	2506	2508	2510	units
Maximum phase temperature	100	100	100	100	°C
Thermal resistance Rth _{phase-housing}	0.41	0.27	0.20	0.16	°C/Watt
With 25 x 25 x2.5cm heatsink plate					
Power dissipation @ 25°C ambient	62.3	77.0	89.2	100.2	Watt
Thermal resistance Rth _{housing-ambient}	0.79	0.69	0.64	0.59	°C/Watt
Without heatsink plate					
Power dissipation @ 25°C ambient	43.1	56.4	67.6	77.3	Watt
Thermal resistance Rth _{housing-ambient}	1.33	1.06	0.91	0.81	°C/Watt
Thermal time constant	1188	1276	1377	1486	s

MECHANICAL SPECIFICATIONS

FORCER TYPE	2504	2506	2508	2510	units
Maximum stroke	309	309	309	309	mm
Forcer mass (excluding thrust rod and cable)	1.25	1.70	2.25	2.65	kg
Thrust rod mass/metre	3.5	3.5	3.5	3.5	kg/m

OUTLINE DRAWINGS

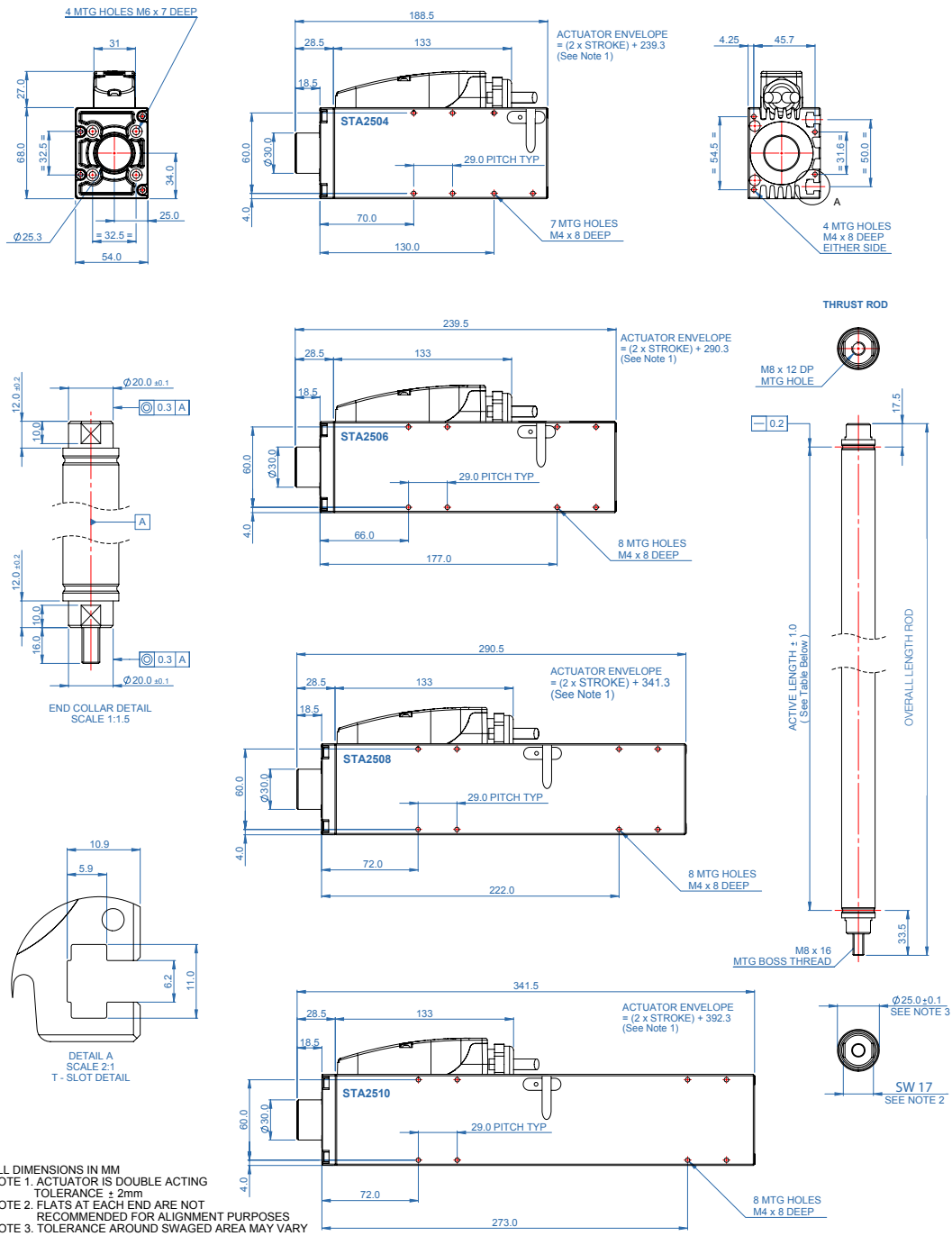

Stroke (mm)	2504	2506	2508	2510
Overall length rod				
27	266	317	368	419
53	292	343	394	445
78	317	368	419	470
104	343	394	445	496
130	369	420	471	522
155	394	445	496	547
181	420	471	522	573
206	445	496	547	598
232	471	522	573	624
258	497	548	599	650
283	522	573	624	676
309	548	599	650	701

Longer strokes are possible depending on the application

POSITION SENSOR

The position sensor outputs analogue, differential sine and cosine signals for providing position feedback. Shown below are the relationships between forcer phase back EMF and position sensor outputs for one direction of motion (as shown by arrows). It should be noted that +SIN or -SIN is always in phase with forcer phase U. For the motion shown, -SIN is in phase with forcer phase U. For motion in the opposing direction +SIN is in phase with forcer phase U.

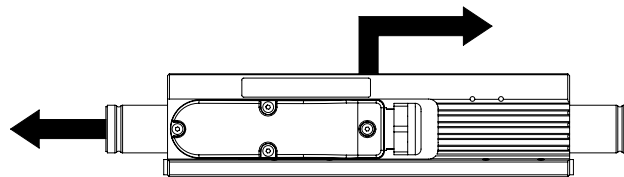
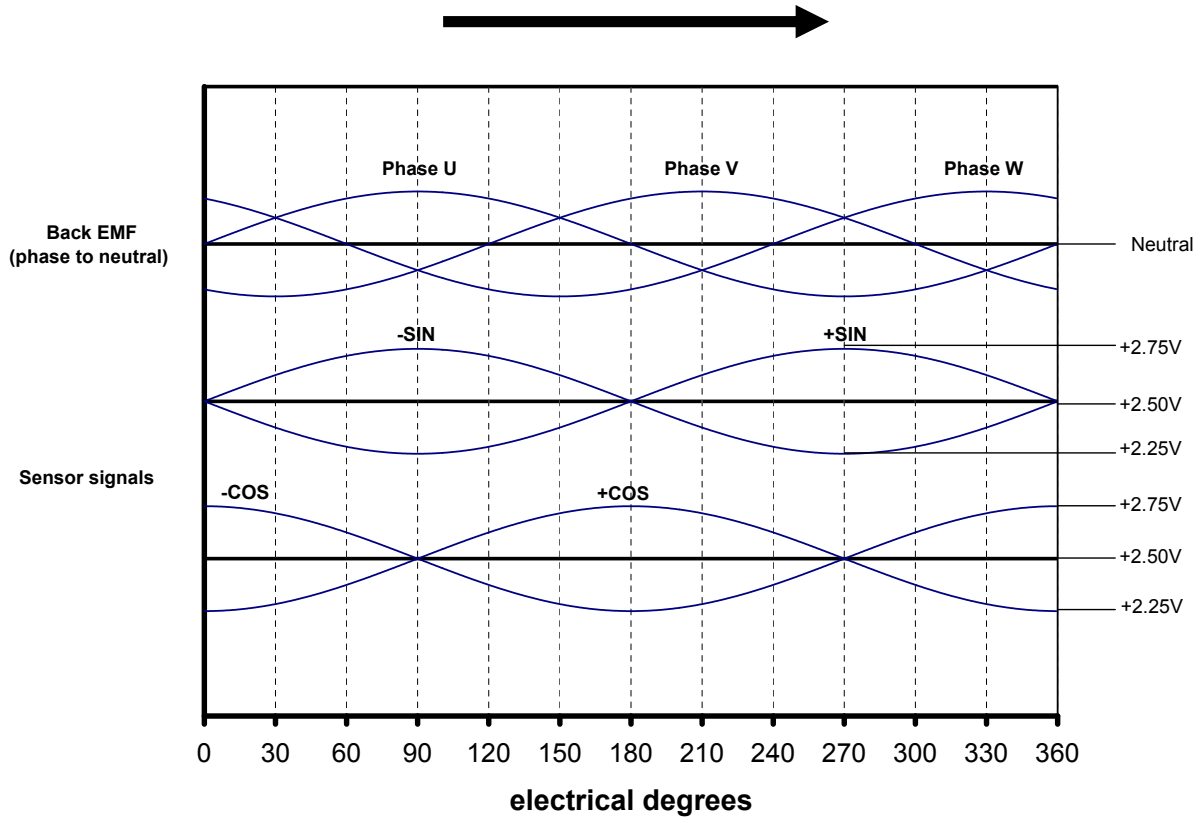

SPECIFICATION	VALUE	units
Output signal period	51.2	mm
Signal amplitude (between +/- signals)	1	Vpk-pk
Output current	± 10	mA
Supply voltage	5 ± 0.25	Vd.c.
Supply current (output current=0)	15 ± 5	mA
Resolution ⁽¹⁾	12	micron
Position repeatability ⁽²⁾	± 12	micron
Absolute accuracy ⁽³⁾	± 350	micron

Notes:

- ⁽¹⁾ Dependent on amplifier (indication with 12 bit resolution)
- ⁽²⁾ Dependent on amplifier. Under constant operating conditions. Self-heating of the forcer will cause expansion in the thrust rod during the initial warm up period. In high duty applications (corresponding to an internal forcer temperature of 80°C) a 1 metre thrust rod will expand typically by 250 microns.
- ⁽³⁾ Maximum error over 1 metre under constant operating conditions.

FORCER OVER TEMPERATURE SENSOR



It is strongly recommended that the forcer over-temperature sensor is connected to the drive amplifier or servo controller **at all times** in order to reduce the risk of damage to the forcer due to excessive temperatures.

Protection is provided by three positive temperature coefficient (PTC) thermistors embedded in the forcer phases. As the forcer phase temperature approaches 100°C, the PTC thermistors exhibits a sharp increase in electrical resistance. This change in resistance can be detected by circuitry within the drive amplifier or servo controller and used to reduce or disable the output of the drive amplifier in order to protect the forcer.

SPECIFICATION	VALUE	units
Resistance in the temperature range -20°C to + 70°C	60 to 750	Ohms
Resistance at 85°C	≤1650	Ohms
Resistance at 95°C	≥3990	Ohms
Resistance at 105°C	≥12000	Ohms
Maximum continuous voltage	30	Vd.c.

FORCER ELECTRICAL CONNECTIONS

Connections are made within the termination box.

PIN NUMBER	FUNCTION
1	Phase U
2	Phase V
3	Phase W
Chassis	Earth/Screen

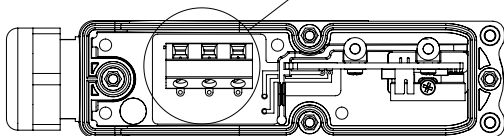
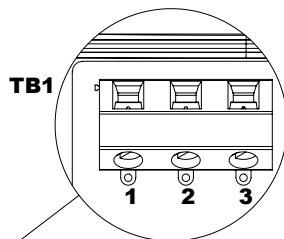

PIN NUMBER	FUNCTION
1	+SIN
2	-SIN
3	+COS
4	-COS
5	+5Vd.c.
6	0V
7	+TH (Thermistor)
8	-TH (Thermistor)

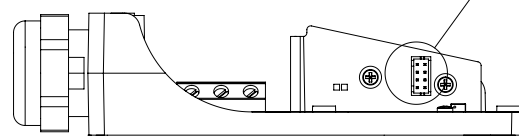
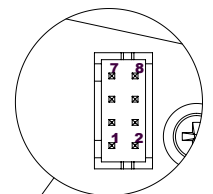

CABLE TYPE

The STA has two separate cables providing connections for forcer power and position sensor. Cable types are available in 3 metre, 5 metre or 10 metre lengths.

Cables are suitable for continuous flex or drag chain applications.

	POWER	SENSOR
Overall diameter (nominal)	8.0mm	5.8mm
Outer jacket material	PUR	PUR
Number of conductors	4	4 x twisted pair
Size of conductors	1.5mm ² (16 AWG)	0.14mm ² (26AWG)
Screened / Unscreened	Screened	Screened
Minimum bending radius - flexible routing	42mm	42mm
Operating temperature - flexible routing	-15°C to +80°C	-15°C to +80°C
Operating temperature - fixed routing	-30°C to +80°C	-30°C to +80°C

CABLE TERMINATION

The STA cable is available with three termination options. **Option F** has the wire ends stripped and solder tinned ready for termination. All other options are terminated with connectors that plug directly into the desired amplifier. The connections for all options are shown below: -

SENSOR FUNCTION	D - (XTL-S)	N - (ESR-Pollmeier)	F - (Flying leads)
+SIN	14	6	Blue
-SIN	13	7	Red
+COS	12	11	White
-COS	11	12	Brown
+5Vd.c.	4	10	Yellow
0V	5	15	Green
+TH (Thermistor)	10	5	Pink
-TH (Thermistor)	15	15	Grey
SCREEN	1+ shell	Shell	SCREEN
Connector type	15-way high density D	15-way high density D	-
Amplifier connection	J8	X6.2	-
POWER FUNCTION			
Forcer phase U	4	U	Black <u>1</u>
Forcer phase V	3	V	Black <u>2</u>
Forcer phase W	2	W	Black <u>3</u>
Earth (forcer body)	1	PE	Green/Yellow
SCREEN	1	Shell	SCREEN
Connector type	4-way 5mm pluggable terminal	4-way pluggable terminal	-
Amplifier connection	J2	X3	-

BRAKE INFORMATION (OPTIONAL)

When selecting the brake, the stroke is reduced by 60 mm.

ENVIRONMENT

The STA is intended for use in an environment within the following conditions:

SPECIFICATION	VALUE
Operating temperature	0°C to +40°C
Storage temperature	-25°C to +70°C
Ingress protection	IP67
Altitude (above mean sea level)	1000m
Overvoltage category	II
Pollution degree	2
EMC	light industrial

In addition, the STA is available with two environmental coating options. The forcer body is coated as standard with a 25 micron layer of black anodise that is suitable for general use. **Option H** has the forcer body coated with a 90 micron layer of hard natural anodise that is suitable for harsher environments. This option is available at a minimum quantity of 25 pieces per year.

ORDER CODE

Actuator

STA25 - - - -

Forcer

04, 06, 08, 10

Winding

S - Series
P - Parallel

Stroke

027, 053, 078, 104, 130, 155
181, 206, 232, 258, 283, 309

Stroke in mm

Environment

S - Standard
H - Harsh (on request)

Brake

blank - no brake
BR - Brake

Cable Termination

D - Xenus (XTL-S)
F - Flying leads
N - ESR Pollmeier

Cable Length

03 - 3 m
05 - 5 m
10 - 10 m

Cable Type

R - Robotic

Features

- » Vertical Holding Brake
- » Holding Force > 200N
- » 24 Volt DC supply
- » Fail Safe Operation



The OEM advantage

- » High holding force in small package
- » Reliable and cost-effective
- » No maintenance or adjustment

OVERVIEW

The ServoTube brake provides a solution to power down parking of vertical axes and controlled deceleration of axes during power fail conditions. The brake is a bolt-on addition to any STA25 forcer and is IP67 rated. It is a unidirectional self-jamming design, which uses the motor's motion to create the necessary forces for braking the system. To minimize size, the brake is designed to be reset by the motor itself. Once reset, it is held off by a compact 24V electromagnet. The motor is then free to operate as normal until the release of power to the brake.

OPERATION

From power-on, the brake must be released before normal operation of the motor.

Release:

1. Apply power to the forcer and drive the thrust rod UP by applying sufficient force to overcome the braking action (70-80N).
2. Continue driving UP until the STOP on the thrust rod activates the BRAKE RELEASE. Activation can be detected by the controller when velocity=0 or there is no change in position.
3. Apply 24V to brake solenoid.
4. Wait 100ms.
5. The brake will now hold off and the forcer can operate as normal.

Activate:

1. Remove 24V from the brake solenoid. The thrust rod will fall a very short distance before the brake activates.
2. Wait 100ms.
3. Disable the servo to remove power from the forcer.

SPECIFICATIONS

Angabe	Wert
Environment	
Operating temperature	0°C ... +40°C
Humidity (relative)	0 ... 95% (non-condensing)
Electrical data	
Power requirement	24VDC +/- 10%
Power dissipation	4 W
Brake	
Holding force	>200 N
Reset force (using motor)	50 ... 70 N
Mass	0,26 kg

OUTLINE DRAWINGS

SBA25

