

- » High efficiency
- » Output shaft with double ball bearings
- » All stages have straight toothing

- » Hoher Wirkungsgrad
- » Ausgangswelle doppelt kugellagert
- » Alle Getriebestufen geradverzahnt ausgeführt



Lifetime lubrication



High efficiency



Protection class (up to)



Vibration resistance

## Data/ Technische Daten | PLG 42 K - Ring gear made of plastic/ Hohlrads aus Kunststoff

Reduction ratio/ Untersetzungsverhältnis	-	4	6.25	8	16	25	32	50	64	100	128	156.25	200	256	312.5	400	512
Efficiency/ Wirkungsgrad	%	90			81				73								
Number of stages/ Stufenzahl	-	1			2				3								
Continuous torque/ Dauerdrehmoment	Nm	0.7			1.3				3								
Weight of gearbox/ Getriebege wicht	kg	0.16			0.20				0.25								
Axial load/ radial load* / Axiallast/ Radiallast*	N	150 / 230			150 / 230				150 / 230								

\* From center of shaft/ Ab Wellenmitte

## Dimensions in mm/ Maßzeichnung in mm

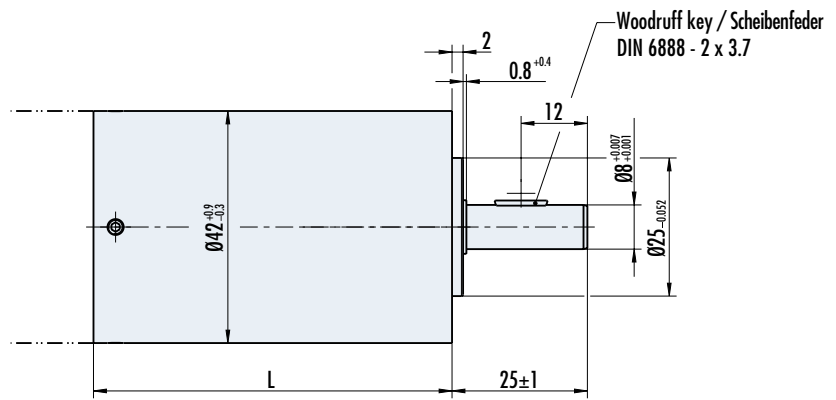
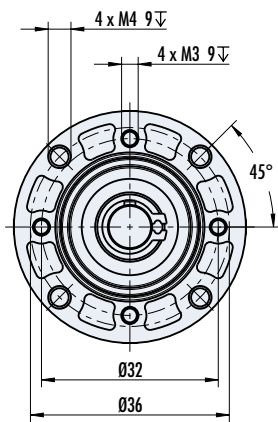

Length/ Länge L mm

1-stufig/ stage	46.8
2-stufig/ stage	58.6
3-stufig/ stage	70.4

Depending on the motor type, the mounting pattern may be rotated by 45°. Please ask us for details/  
Je nach Motortyp kann die Anbaulage um 45° gedreht sein. Bitte fragen Sie uns nach Details.