

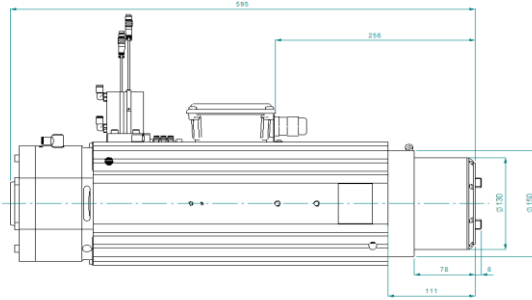

## Electrospindle ATC 8kW 12.000 rpm GX-1 8/6 12 NC I40T IDX

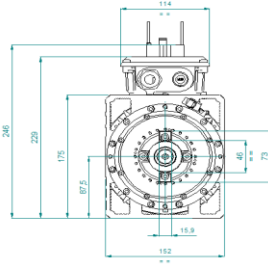

### Prestazioni - Performances

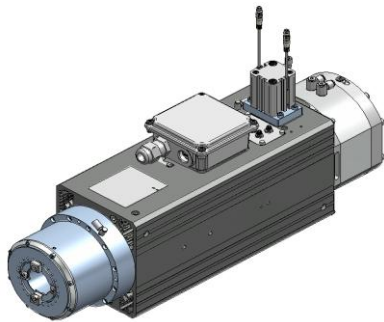
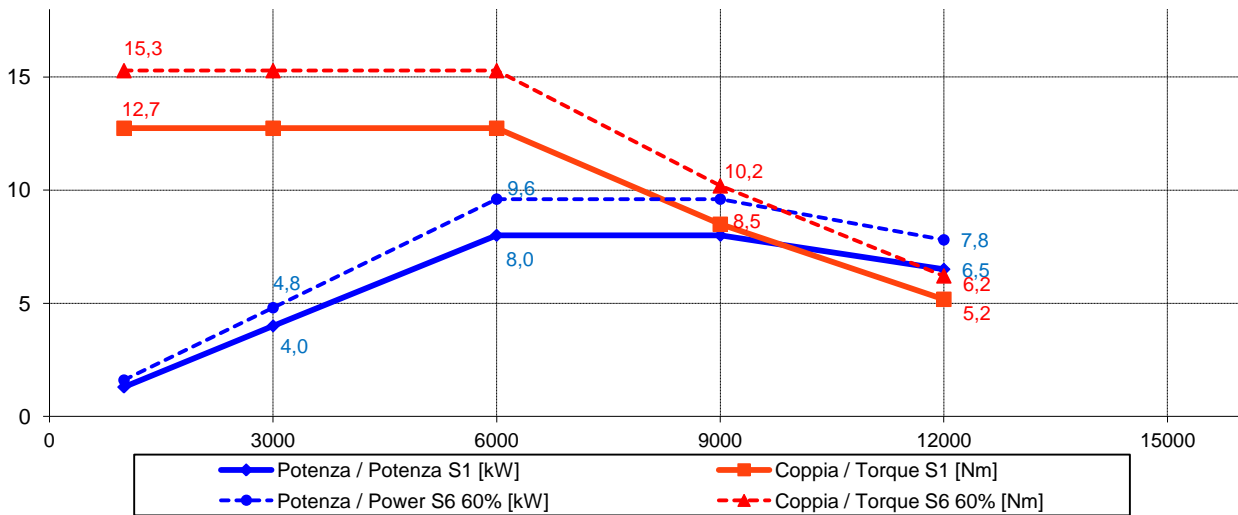

### Specifiche tecniche/ Technical Specifications

Tipologia elettromandrino / Electrospindle type

Attacco utensile / Tool interface

Velocità rotazione max / Max speed

Raffreddamento / cooling

Lubrificazione cuscinetti / Bearings lubrication

Connessione pneumatiche / Pneumatic connection

Potenza max. (S1 - S6) / Max. Power.(S1 - S6)

Coppia max. (S1 - S6) / Max. Torque (S1 - S6)

Corrente (S1 - S6) / Current (S1 - S6)

Tensione / Voltage

Rotazione / Rotation

Azionamento / Supply

Sensoristica / Sensors (connettori / plug-in connector M8)

Peso / Weight

Asincrono-4 poli / Asynchronous-4 poles

ISO 40T

12000 rpm

Ventola calettata su albero / Fan fitted on the shaft

Grasso a vita / Grease long life

Sblocco uten. / Release. tool: Ø6 6-6.5 bar

Blocco/Lock tool: Ø6 6-6,5 bar

Pressurizzazione / Air seal.: Ø4 6-6.5 bar

Index albero (x2) / Shaft index (x2): Ø4 1.5-2 bar

Ingresso acqua per giunto/Joint water inlet : G1/4

8 kW @6000 rpm (S1) / 9.6 kW @ 6000 rpm (S6)

12.7 Nm (S1) / 15.3 Nm (S6)

17 A (S1) / 20 A (S6)

380 V

CW - CCW

Con inverter / By inverter

S1 Afferraggio utensile / S1 Tool lock

S2 Pinza aperta / S2 Open clamp

S3 Rotazione albero / S3 Spindle rotation

Index albero (x2) / Shaft index (x2)

58 kg