

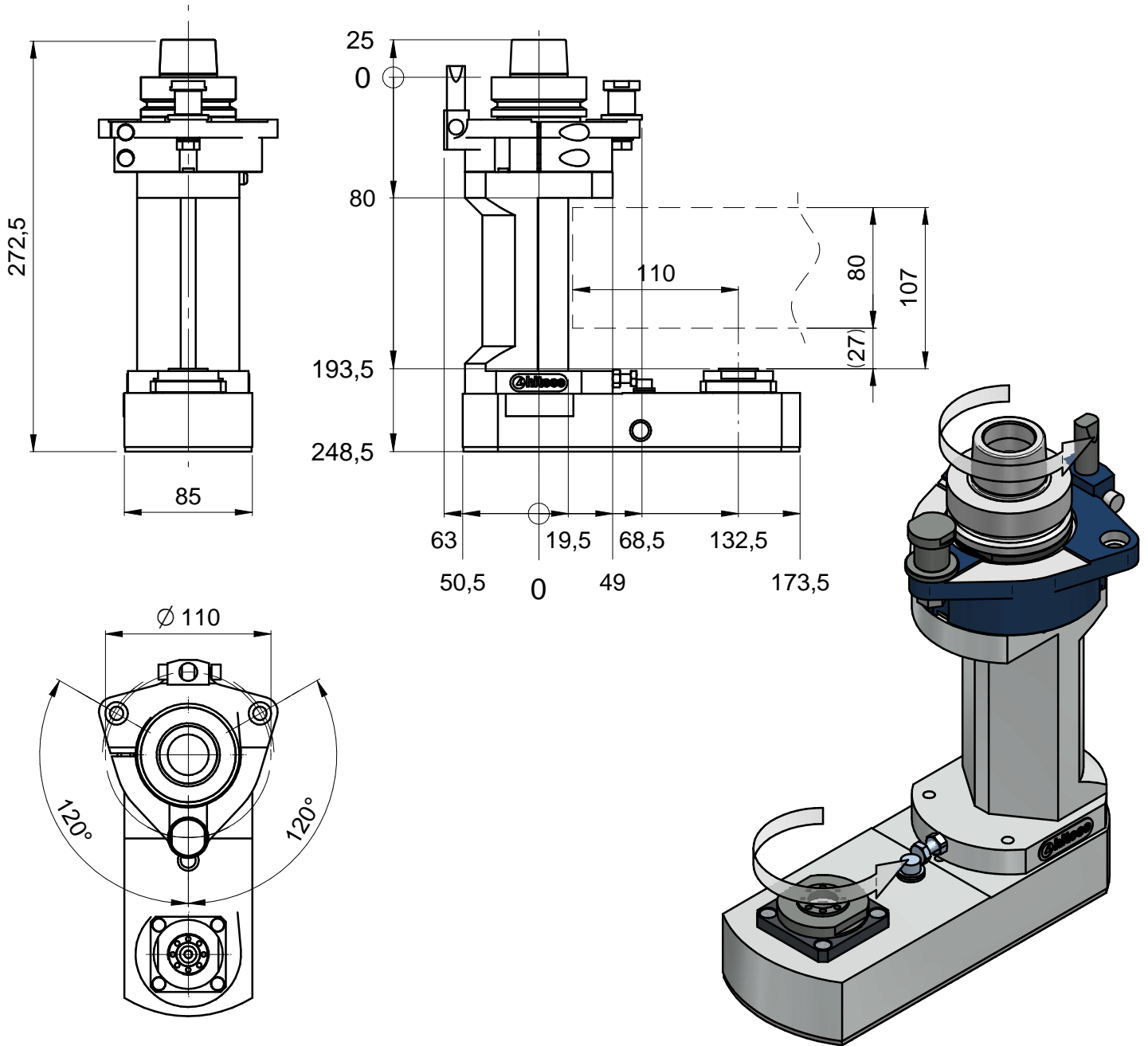

Unità Aggregata / Aggregate Unit : **Master Line DSIDE ER20 H195**
 Codice / Code : **ML.DSIDE.00/195N63F-H1**



Specifiche tecniche / Technical specifications

| | |
|--|----------------------------------|
| Attacco mandrino / Spindle coupling | HSK63F |
| Velocità Rotazione Max. / Max. Speed | 13000 rpm max * |
| Rapporto di trasmissione / Gear ratio | 1:1 |
| Senso Rotazione Mandrino/ Electrospindle rotation | VEDI DISEGNO- SEE DRAWING |
| Possibilita' inversione rotazione / Possibility to change electrospindle direction | NO |
| Attacco utensile / Tool coupling | ER20 |
| Diametro max.punta / Max. bit diameter | ø 13 mm |
| Profondita di lavorazione / Working depth | VEDI DISEGNO- SEE DRAWING |
| Diametro lama / Blade diameter | - |
| Temperatura / Temperature | 75 °C / 167 °F max |
| Connessione asse C / C axis connection type | HIT1 |
| Orientamento angolare/ aggregate rotation | 0 -360° in continuo / continuous |
| Peso | ~6 kg |
| * vedere manuale / see user manual | |