

Linear motor drive

**Function:**

This unit consists of a rectangular aluminium profile with 2 integrated roller guides. The linear motor DLM unit is based on the principle of a linear, synchronous AC motor.

The guiding profile is fitted with permanent magnets as stator (secondary part). The carriage is fitted with the actuator (primary part). The magnetic attraction causes a force between carriage and guiding profile also in the absence of current. This force can be used for the initial tension of the bearings. Several carriages (primary parts) can be driven independently on one guiding profile.

Fitting position: As required. Max. length 6.000 mm without joints.

Carriage mounting: By T-slots.

Unit mounting: By T-slots and mounting sets. The linear axis can be combined with any T-slot profile.

Carriage support: In the standard version, the carriage runs on 10 or 12 rollers which can be adjusted and serviced at a central servicing position. For longer carriages the number of rollers can be increased.
Repeatability $\pm 0,05$ mm. Repeated accuracy max. $\pm 0,05$ bis 4.000 mm, $\pm 0,1$ >4.000 mm.

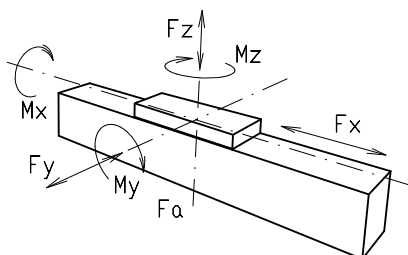
Forces and torques

F_z = external force by load
 F_a = magnetic attraction force
 F_{zm} = maximum force in consideration of motor power
 $F_{zm} = F_z + F_a$

Size	120			160			200		
Motor size	1	2	3	1	2	3	1	2	3
Forces/Torques _{dyn}									
F_a (N)	600	1200	1800	1200	1800	5500	3600	5500	11000
F_{zm} (N)	820	1640	2460	1590	8800	7030	5000	7500	13800
F_y (N)	700	700	470	1500	1000	450	3300	2200	1200
M_x (Nm)	180	90	60	280	190	130	600	400	220
M_y (Nm)	50	100	70	320	210	140	640	420	230
M_z (Nm)	22	33	50	90	100	120	200	170	210
Number of rollers	10	12	12	12	12	12	12	12	12
All forces and torques related to the following:									
existing values	$\frac{F_y}{F_{y_{dyn}}} + \frac{F_{zm}}{F_{zm_{dyn}}} + \frac{M_x}{M_{x_{dyn}}} + \frac{M_y}{M_{y_{dyn}}} + \frac{M_z}{M_{z_{dyn}}} \leq 1,5$								
table values									
Motor specifications F_x									
Motor size	1	2	3	1	2	3	1	2	3
Carriage weight (kg)	1,7	2,5	3,1	5,1	4,7	5,4	9,4	10,5	12,7
Weight primary part (kg)	0,7	1,4	2,0	1,4	3,7	5,2	4,5	6,4	8,4
permanent (N)	61	115	173	115	271	406	383	574	766
Max. (N) (1sek.)	162	323	485	323	607	911	868	1301	1735
Moving force without current									
N	3	5	6	5	8	9	7	11	12
Speed									
(m/sec) max	4			6			6		
Geometrical moments of inertia of aluminium profile									
I_x mm ⁴	$6,6 \times 10^5$			$22,2 \times 10^5$			$63,8 \times 10^5$		
I_y mm ⁴	$38,6 \times 10^5$			$122,0 \times 10^5$			$335,0 \times 10^5$		
Elastic modulus N/mm ²	70000			70000			70000		

Formula: DLM

$$f = \frac{F \cdot L^3}{E \cdot I \cdot 192}$$

f = deflection (mm)
 F = load (N)
 L = free length (mm)
 E = elastic modulus 70000 (N/mm²)
 I = second moment of area (mm⁴)

Positioning system DLM 120, 160, 200

Dimensions (mm)

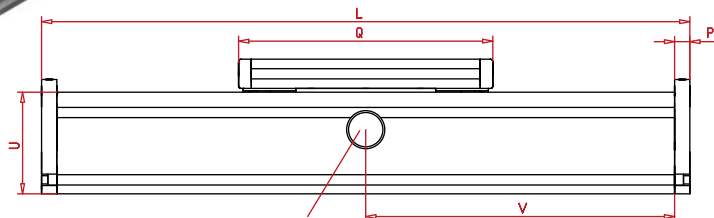
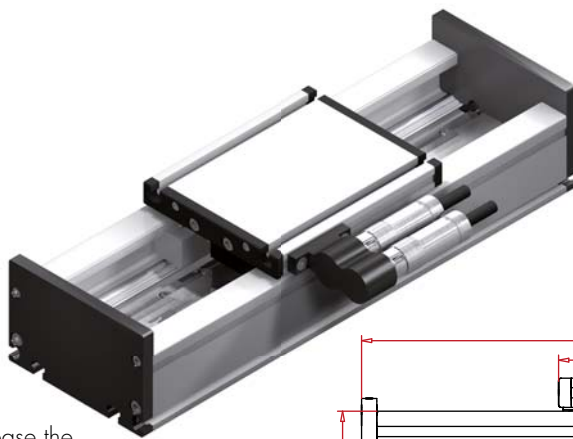
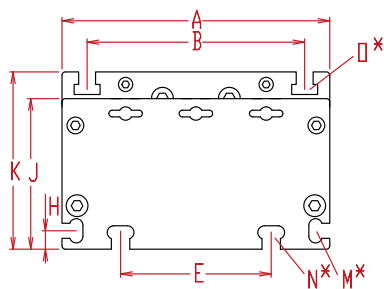

Increasing the carriage length will increase the basic length by the same amount.

*For slide nuts refer to chapter 2.2 page 2

$V = Q + 100 \text{ mm}$ $W = \text{servicing position}$

Size □	Basic length L	A	B	E	H	J	K	M for	N for	O for	P	U	Basic weight Motor size 1/2/3	Weight per 100 mm Motor size 1/2/3
DLM 120	Q + 30	120	96	78	10	68	79	M 5	M 6	M 6	10	60	5,2/7,2/9,2 Kg	1,0/1,0/1,0 Kg
DLM 160	Q + 30	160	130	90	11	90	106	M 6	M 8	M 8	12	80	12,6/15,6/20,7 Kg	1,6/2,0/2,0 Kg
DLM 200	Q + 35	200	160	140	15	110	129	M 8	M 10	M 10	15	100	26,9/30,5/37,9 Kg	2,6/2,6/2,6 Kg

0 Choice of guide body profile:

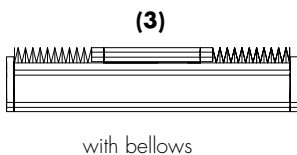
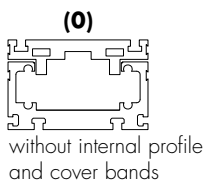

Stainless version upon request.

1 Measurement system:

- (1) Measurement system LE100 5V Resolution 0.05
- (2) Measurement system LE100 10,5-30V Resolution 0.05
- (3) Hall sensor
- (4) Measurement system provided by customer

1 Plug:



1 Motor size:

- (1) Motor size 1 with Q_1
 - (2) Motor size 2 with Q_2
 - (3) Motor size 3 with Q_3
 - (4) Supply with Q_1^*
 - (5) Supply with Q_2^*
 - (6) Supply with Q_3^*
- * = provided by customer

Dimensioning criteria for motor output						
	l_p □	b_p □	h_{ps} □	Q_1	Q_2	Q_3
120	Q - 70	55	38	196	276	372
160	Q - 70	71	50	316	360	461
200	Q - 70	85	62	410	444	610

l_p = length primary part; b_p = width primary part;
 h_{ps} = height primary part + height secondary part + interspaces primary-/secondary part

For standard carriage length see 'Q' in table.
 For digital controllers and linear encoder refer to chapter 9.1 page 10.

1500 Basic length + stroke = total length

DLM	160	0	0	1	1	0	0	1	01500
	Pos. 1	2	3	4	5	6	7		

Sample ordering code:

DLM160, Bahr Modultechnik Linearmotor, standard body profile, Measurement system LE100 5V, Plug Pos. 1, motor size 1, 1154 mm stroke.