

CARTRIDGE DDR™

Motor Mounting Instructions

Step 1 Check Machine Mounting Dimensions



Incorrect mounting dimensions can damage Motor and/or Machine.

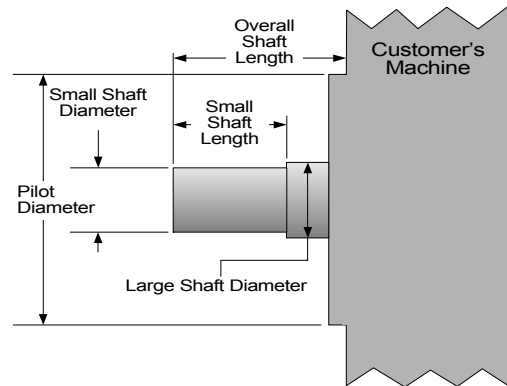

Check Here

| Diameter | C(H)09X | C(H)13X |
|-------------|--------------------------------------|--------------------------------------|
| Pilot | 9.170 - 9.172 [232.92 - 232.96] | 13.147 - 13.149 [333.94 - 333.98] |
| Large Shaft | 2.7554 - 2.7559 [69.988 - 69.999] | 3.1491 - 3.1496 [79.988 - 79.999] |
| Small Shaft | 2.3617 - 2.3622 [59.988 - 59.999] | 2.7554 - 2.7559 [69.988 - 69.999] |

| Shaft Length | C(H)091 | C(H)092 | C(H)093 |
|-------------------------|------------------|-------------------|-------------------|
| Small ± 0.005 [0.13] | 1.730 [43.94] | 3.470 [88.14] | 4.910 [124.71] |
| Overall ± 0.06 [1.5] | 3.540 [89.92] | 5.280 [134.11] | 6.720 [170.69] |

| Shaft Length | C(H)131 | C(H)132 | C(H)133 |
|-------------------------|-------------------|-------------------|-------------------|
| Small ± 0.005 [0.13] | 1.590 [40.39] | 3.300 [83.82] | 4.670 [118.62] |
| Overall ± 0.06 [1.5] | 4.490 [114.05] | 6.610 [167.89] | 9.980 [253.49] |

With a dial indicator measure shaft runout.
0.038 mm (0.0015 in) TIR

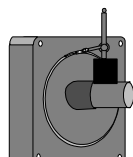

With a dial indicator mounted to the shaft, measure Pilot Concentricity.
0.05mm (0.002 in) TIR

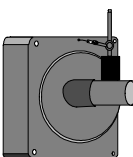

With a dial indicator mounted to the shaft, measure Mounting Surface Perpendicularity.
0.05 mm (0.002 in) TIR

Step 2 Secure Motor to Machine Frame

Check Here

Wipe down shaft and motor's rotor hub bore. Light oil residue is acceptable, but remove grease and other contaminants.

Insert the provided key into the keyway in the shaft with the point toward the end of the shaft.

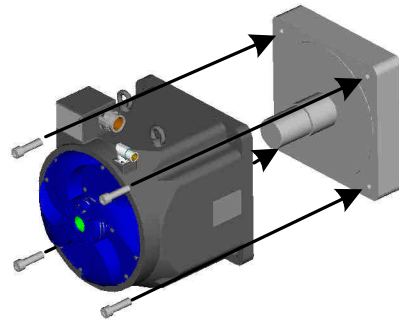

Slide motor onto the shaft. Secure the motor to machine frame using four (4) bolts (not included).

Step 3 Remove End Cover

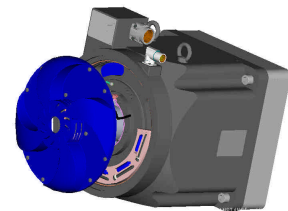

Using a Phillips screw driver, remove the blue end cover by loosening the pan head screws (eight (8) on the C(H)09 and twelve (12) on the C(H)13.

Step 4 Tighten Compression Coupling

Access compression coupling bolts through holes labeled "A". Use 6 mm hex bit attached to a torque wrench. There are (6) compression coupling bolts on C(H)09 motor and (10) on the C(H)13.

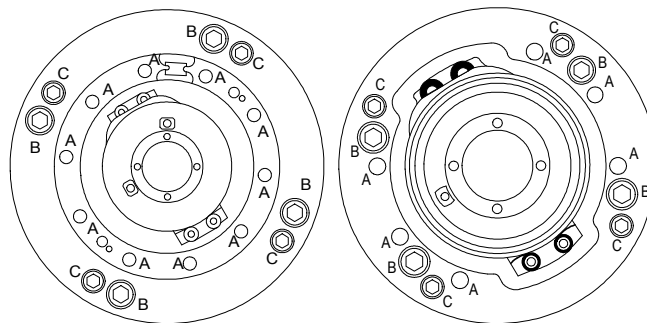

C13

C09

Hand tighten each bolt in a circular pattern to approximately 0.1 N-m (1 lb-in.).

Tighten each bolt in a circular pattern, twice around to 13 N-m (10 lb-ft).

Retighten each bolt in a circular pattern, twice around to 20 N-m (15 lb-ft).

Retighten each bolt in a circular pattern, twice around to 30 N-m (22 lb-ft).

Go around, tightening each bolt to 30 N-m (22 lb-ft) until no bolt moves (may take up to 8 complete revolutions).



Properly torque the compression coupling to avoid significant damage to the motor and the machine to which it is mounted.

Step 5 Remove and Secure Shipping Hardware

Check Here

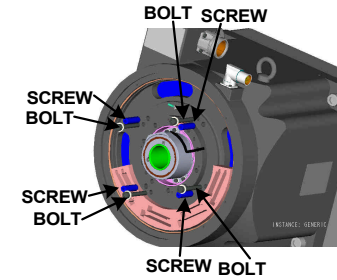

Remove (4) shipping bolts "B" and (4) set screws "C" using 6 mm hex wrench.

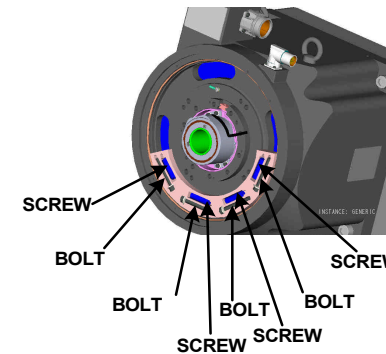

Place shipping bolts and set screws into foam holder.

Step 6 Confirm Free Rotation

Rotate load by hand to insure free movement.

Step 7 Replace End Cover

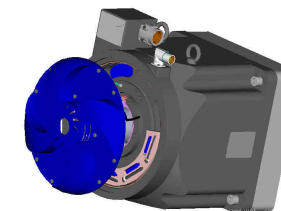

Ensure the O-ring on the outside of the end cover is in place.

Rotate the end cover until the alignment mark matches the corresponding mark on the housing.

Secure the end cover by tightening the pan head screws (eight (8) on the C(H)09 and twelve (12) on the C(H)13).

Congratulations!
Your CARTRIDGE DDR™ motor is ready for operation.

CARTRIDGE DDR™ Motor Removal Instructions

Step 1 Remove End Cover

Check Here

Using a Phillips screw driver, remove the blue end cover by loosening the pan head screws (8 screws on the C(H)09 and (12) screws on the C(H)13).



Step 2 Align Rotor

Through Bore Motors Turn Motor shaft by hand until the index mark on the rotor and stator of the encoder line up together.



Solid Shaft Motors Use a flashlight to look into the holes labeled "B". Turn the Motor shaft by hand until there is a threaded hole directly behind each of the four holes labeled "B".



Step 3 Install Set Screws

CAUTION Do not use any type of Loctite or thread lock on the shipping hardware.

Remove the (4) set screws from the foam holder and thread them onto the holes labeled "C". Using a 6 mm hex driver on a torque wrench, tighten each set screw to 0.1 N-m (1 lb-in).

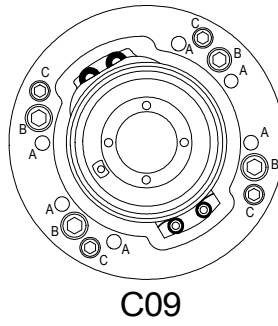
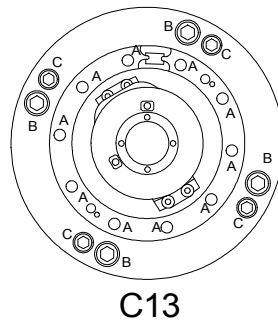
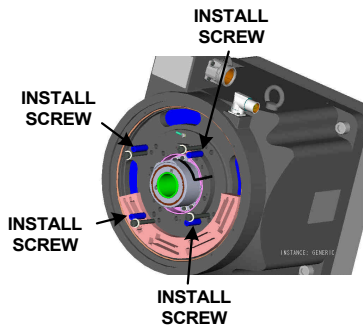

Step 4 Install Shipping Bolts

Check Here

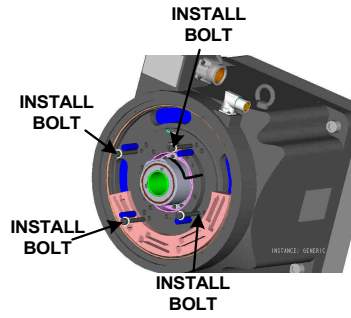

Remove the (4) shipping bolts from the foam holder and thread them into the holes labeled "B". Using a 6 mm hex driver on a torque wrench, tighten each shipping bolt to 16 N-m (12 lb-ft).

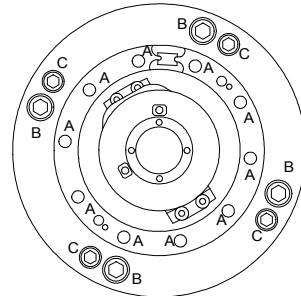

C13

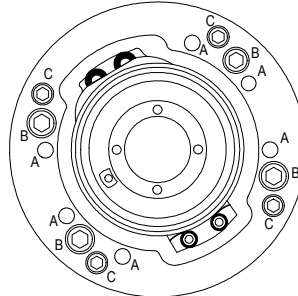

C09

Step 5 Loosen Compression Coupling Bolts

Using a 6 mm hex driver, loosen the compression coupling bolts through the holes labeled "A". There are six (6) compression coupling bolts on the C(H)09 motor and ten (10) on the C(H)13. Loosen the bolts in a circular pattern. Loosen 2 revolutions past the point where the bolts are finger tight. Check each bolt a second time to insure it is loose.



Step 6 Release Compression Coupling

Insert the 6 mm hex driver into one of the compression coupling bolt holes labeled "A" and seat it into the head of the bolt. Lightly tap it with a hammer to release the compression coupling. Repeat this step with another compression coupling bolt exactly opposite the one just tapped.



On C(H)133 models only, to release the rear compression coupling, insert a M6 x 1 x 120 screw or threaded rod into the holes labeled "D" and tighten until the part breaks loose.



Step 7 Replace End Cover

Ensure the O-ring on the outside of the end cover is in place.



Rotate the end cover until the alignment mark matches the corresponding mark on the housing.



Secure the end cover by tightening the pan head screws (eight (8) on the C(H)09 and twelve (12) on the C(H)13).



Step 8 Remove Motor From Machine

Remove the (4) mounting bolts securing the motor frame to the machine and slide the motor off the shaft. The threaded holes (M10 on C(H)09x or M12 on C(H)13x) beside the mounting holes are provided for jacking purposes, if necessary.



Step 9 Cover Mounting End

Secure a cardboard cover to the open mounting end of the motor.



CAUTION The mounting end of the motor is magnetized and will attract magnetic material. This end of the motor must be covered to insure proper cleanliness.

Customer Support

Danaher Motion products are available worldwide through an extensive authorized distributor network. These distributors offer literature, technical assistance, and a wide range of models off the shelf for the fastest possible delivery.

Danaher Motion sales engineers are conveniently located to provide prompt attention to customer needs. Call the nearest office for ordering and application information or for the address of the closest authorized distributor. If you do not know who your sales representative is, contact us:

203A Rock Road
Radford, VA 24141
Phone: 540-633-3400
Fax: 540-639-4162
Email: customer.support@danahermotion.com
Web: www.DanaherMotion.com

Danaher Motion® is a registered trademark of the Danaher corporation. Danaher Motion makes every attempt to ensure accuracy and reliability of the specifications in this publication. Specifications are subject to change without notice. Danaher Motion provides this information "AS IS" and disclaims all warranties, express or implied, including, but not limited to, implied warranties of merchantability and fitness for a particular purpose. It is the responsibility of the product user to determine the suitability of this product for a specific application.