

# TESTE BIROTATIVE BIROTARY UNITS



METAL

PLASTIC

ADVANCED  
MATERIALS

LIGHT  
ALLOY

WOOD

**HITECO**  
HIGH TECHNOLOGY COMPONENTS

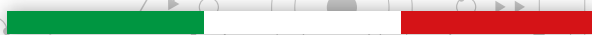

## Componenti ad **alta tecnologia** per produttori di macchine utensili.

--  
**High-tech components** for machine tool manufacturers.

Hiteco è specializzata nella progettazione e realizzazione di componenti elettromeccanici industriali ad alta tecnologia per le macchine utensili.

**Elettromandri ATC, elettromandri MTC, teste birotative, teste di foratura ed aggregati.**

--  
Hiteco is specialized in design and manufacture of high technology industrial electromechanical components for machine tools. **ATC electrospindles, MTC electrospindles, birotary heads, boring units and aggregates.**



Hiteco si propone sul mercato internazionale con un'ampia gamma di prodotti per la lavorazione di: **legno, plastica, materiali avanzati, vetro, pietra e metallo.**

--  
Hiteco offers a wide range of products on international market for **wood, plastic, advanced materials, glass, stone and metal processing.**



Hiteco nasce nel 1977 come divisione interna di **SCM Group**, azienda leader mondiale nella costruzione di macchine utensili per la lavorazione di una vasta gamma di materiali, realizzando un percorso di crescita esponenziale. Diventa nel 2008 **un'unità di profitto per servire il mercato terzi**. Oggi realizza prodotti di riferimento nel mercato dei componenti, diventando uno tra i più importanti player mondiali nel settore.

--  
Hiteco founded in 1977 as an internal division of the **SCM Group**, leading company in machine tools construction for processing a wide range of materials, had an increasingly exponential growth. In 2008 it become **a profit unit for external customers**. Today Hiteco offers key products for the components market, becoming one of the most important world players in the sector.



## Una **presenza capillare** per un **servizio best-in-class e worldwide.**

--  
**A capillary presence** for a **best-in-class** and **worldwide service.**

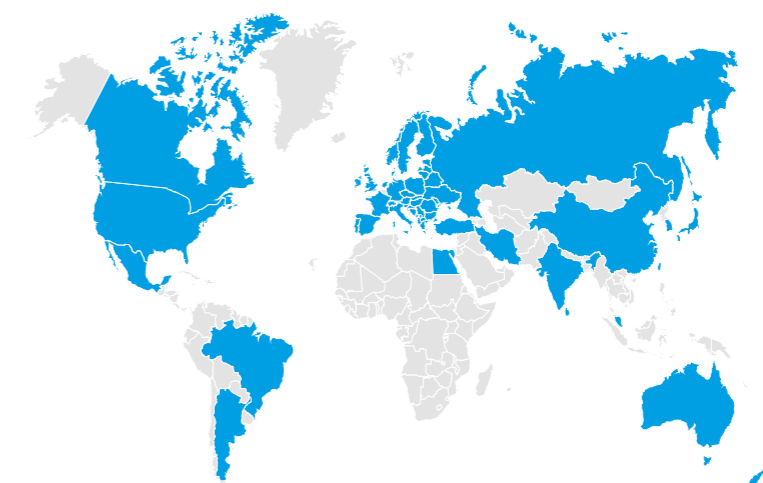

**La distribuzione capillare** dell'azienda risponde alla volontà di Hiteco di essere vicina al cliente con la presenza sul territorio di **tecnici specializzati** che sono garanzia di una risposta estremamente rapida e professionale: non solo per ridurre fermi macchina e problemi alla produzione, ma anche per creare valore aggiunto con la proposta di soluzioni efficaci ed innovative. Questa attenzione, oltre ai ridotti tempi di consegna, è uno dei motivi che ha portato Hiteco ad avere la più alta **customer satisfaction** nel mercato internazionale.

--  
**The widespread distribution** of the company responds to the desire of Hiteco to be close to the customer with the presence of **specialized technicians** on the territory who guarantee an extremely rapid and professional response: not only to reduce machine downtimes and production problems, but also to create added value with the proposal of effective and innovative solutions. Such care, in addition to reduced delivery times, is one of the reason that led Hiteco to have the highest **customer satisfaction** on the international market.



# INDICE INDEX



Dati tecnici e illustrazioni non sono vincolanti e, per il costante sviluppo di prodotti e servizi, HITECO si riserva il diritto di effettuare modifiche senza preavviso.

Technical data and illustrations are not binding and, for the constant development of products and services, HITECO reserves the right to make modifications without prior notice.

Copyright © Hiteco. Tutti i diritti riservati.

Copyright © Hiteco. All rights reserved.

## p.6 **SERIE ORBITAL (50°)**

Legno e materiali avanzati / Wood and advanced materials

- p. 6 Orbital J
- p. 8 Orbital J High Speed
- p. 10 Orbital K
- p. 12 Orbital K Plus
- p. 14 Orbital H

## p.14 **SERIE TILT (90°)**

Materiali avanzati, leghe leggere, plastica e legno / Advanced materials, light alloys, plastic and wood

- p. 16 Tilt J
- p. 18 Tilt J High Speed
- p. 20 Tilt K
- p. 22 Tilt K Plus
- p. 24 Tilt H
- p. 26 Tilt H Plus
- p. 28 Tilt V HT
- p. 30 Tilt V QT
- p. 32 Tilt W
- p. 34 Tilt TLP

**WOOD**

**PLASTIC**

**ADVANCED  
MATERIALS**

**LIGHT  
ALLOYS**

# SERIE ORBITAL ORBITAL J

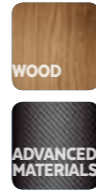

AVAILABLE WITH



## LAYOUT

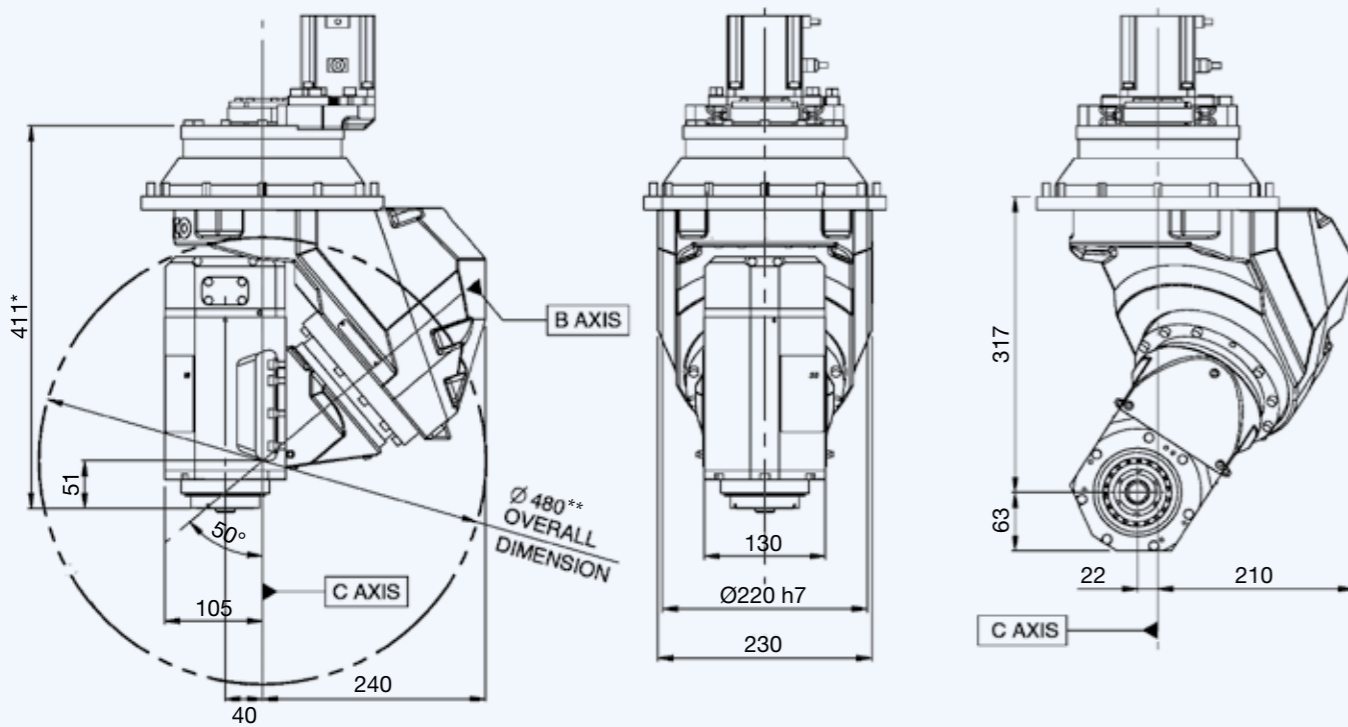

## OPTIONALS DELL'ELETTROMANDRINO / ELECTROSPINDLE OPTIONS

- Monitoraggio temperatura cuscinetti / Temperature monitoring of bearings
- Misuratore di velocità / Speed monitoring
- Sensori di vibrazione / Vibration sensor
- Encoder\*

## SPECIFICHE TECNICHE / TECHNICAL SPECIFICATIONS

\*Sono disponibili altre marche di motorizzazioni a richiesta  
\*Other engine brands are available on demand

	ASSE B / B AXIS	ASSE C / C AXIS
Servomotore / Servomotor	Yaskawa*	Yaskawa*
Potenza servomotore / Servomotor power	0,4 kW	0,4 kW
Encoder servomotore / Servomotor encoder	Assoluto Absolute 20 Bit	Assoluto Absolute 20 Bit
Riduttore / Gearbox	Harmonic Drive	Harmonic Drive
Coppia di stallo / Stall torque	320 Nm	320 Nm
Coppia di picco / Peak torque	570 Nm	570 Nm
Max rotazione asse / Max axis rotation	±185°	±320°
Freni meccanici / Mechanical blocking of axes	No	No
Velocità posizionamento max / Max. positioning speed	7.000°/'	7.000°/'
Precisione di posizionamento assi / Axis positioning accuracy	1 arcmin	1 arcmin
Peso / Weight		55 kg

## ELETTROMANDRINI DISPONIBILI / AVAILABLE ELECTROSPINDLES

### QX-2 8.5/12 24 63F NC

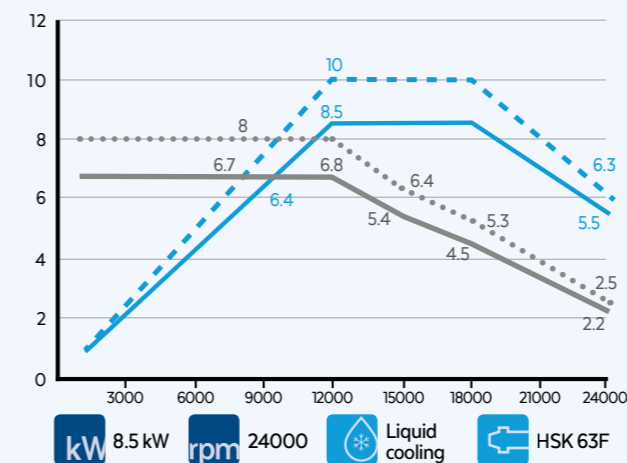

### QX-2 10/12 24 63F NC

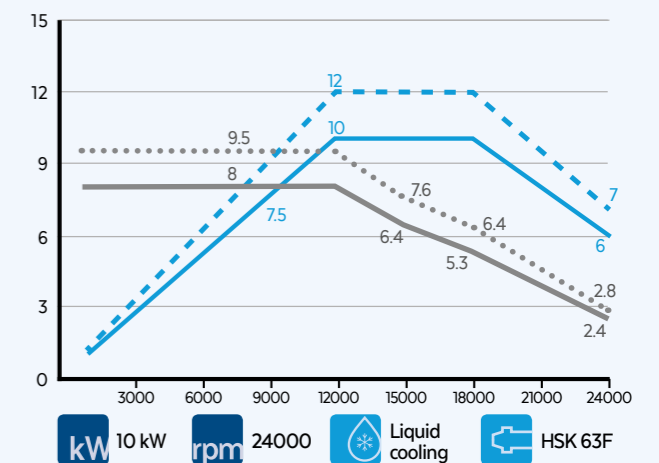

### QX-2 11/12 24 63F NC

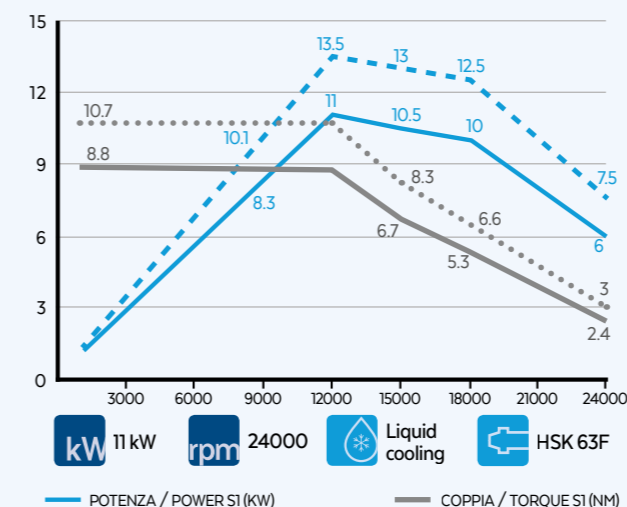

### QX-1C 5/12 21 63F NC

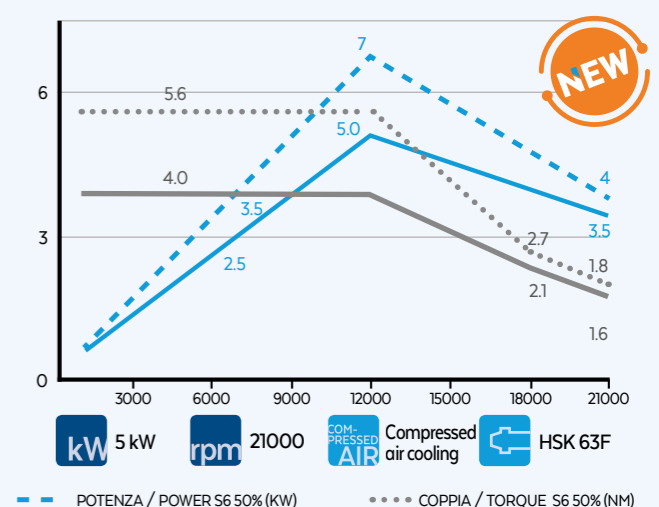

\*L'opzionale encoder comporta un aumento di 25 mm rispetto alla quota riportata nello schema / When the unit is with encoder the quote increases by 25 mm from the one represented in the plan  
\*\* Per altri motori +X mm / For other motors +X mm

# SERIE ORBITAL ORBITAL J High Speed

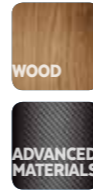

AVAILABLE WITH



## LAYOUT

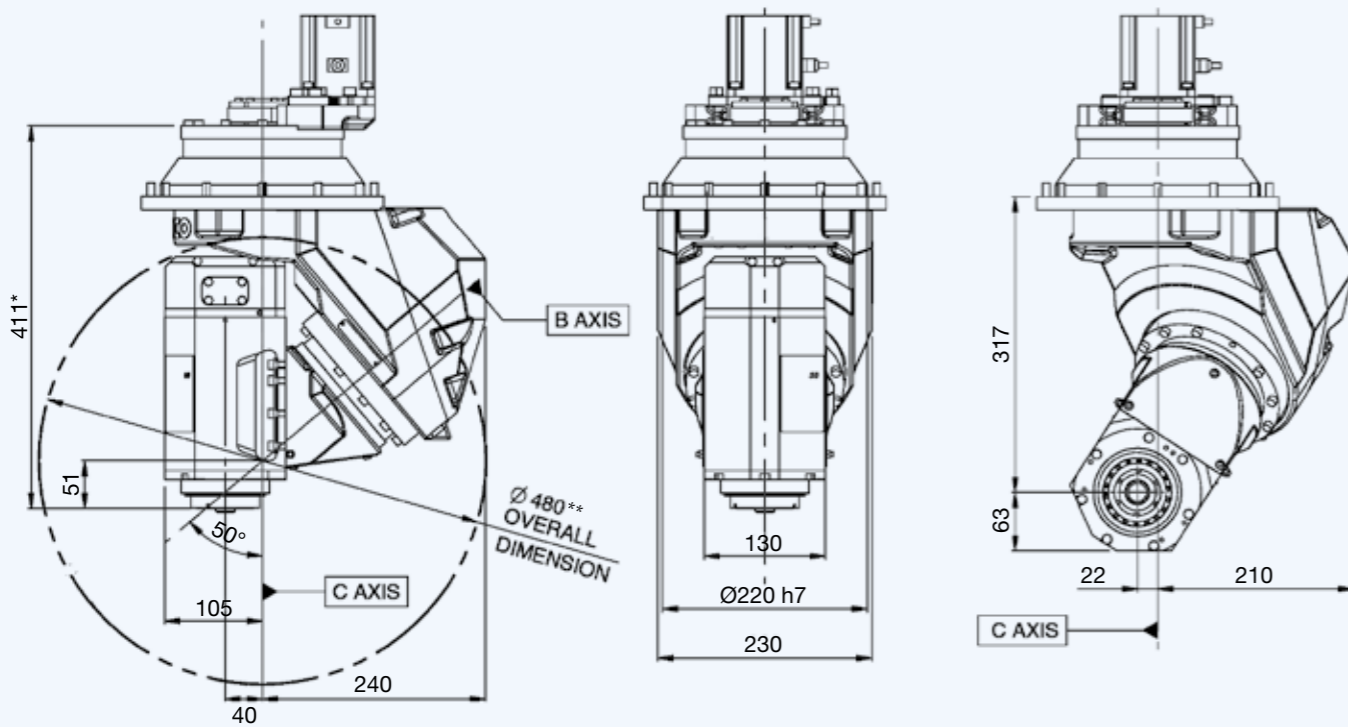

## OPTIONALS DELL'ELETTROMANDRINO / ELECTROSPINDLE OPTIONS

- Monitoraggio temperatura cuscinetti / Temperature monitoring of bearings
- Misuratore di velocità / Speed monitoring
- Sensori di vibrazione / Vibration sensor
- Encoder\*

\*L'opzionale encoder comporta un aumento di 25 mm rispetto alla quota riportata nello schema / When the unit is with encoder the quote increases by 25 mm from the one represented in the plan  
\*\* Per altri motori +X mm / For other motors +X mm

## SPECIFICHE TECNICHE / TECHNICAL SPECIFICATIONS

\*Sono disponibili altre marche di motorizzazioni a richiesta  
\*Other engine brands are available on demand

	ASSE B / B AXIS	ASSE C / C AXIS
Servomotore / Servomotor	Yaskawa*	Yaskawa*
Potenza servomotore / Servomotor power	0,4 kW	0,4 kW
Encoder servomotore / Servomotor encoder	Assoluto Absolute 20 Bit	Assoluto Absolute 20 Bit
Riduttore / Gearbox	Harmonic Drive	Harmonic Drive
Coppia di stallo / Stall torque	320 Nm	320 Nm
Coppia di picco / Peak torque	570 Nm	570 Nm
Max rotazione asse / Max axis rotation	±185°	±320°
Freni meccanici / Mechanical blocking of axes	No	No
Velocità posizionamento max / Max. positioning speed	7.000°/'	7.000°/'
Precisione di posizionamento assi / Axis positioning accuracy	1 arcmin	1 arcmin
Peso / Weight		55 kg

## ELETTROMANDRINI DISPONIBILI / AVAILABLE ELECTROSPINDLES

QX-2 8/15 36 40E NC

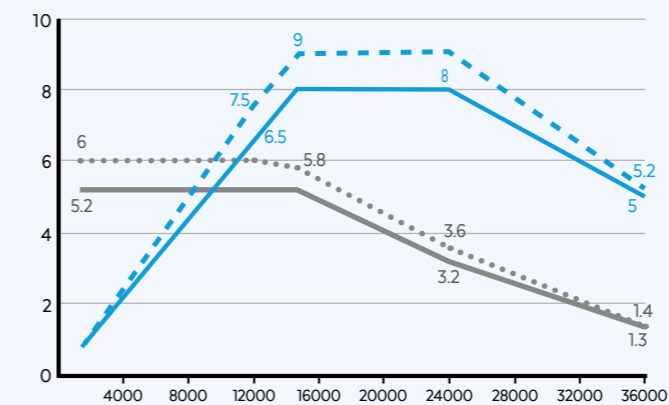

- 8 kW
- 36000 rpm
- Liquid cooling
- HSK 40E

QX-2 8/15 40 32E NC

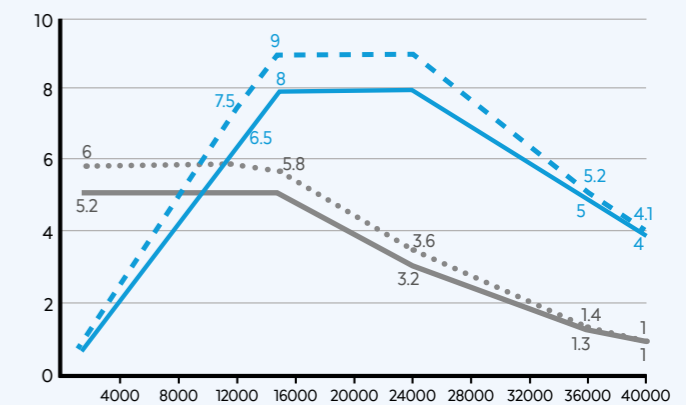

- 8 kW
- 40000 rpm
- Liquid cooling
- HSK 32E

— POTENZA / POWER SI (kW)    — COPPIA / TORQUE SI (NM)    - - - POTENZA / POWER S650% (kW)    ···· COPPIA / TORQUE S650% (NM)

# SERIE ORBITAL ORBITAL K

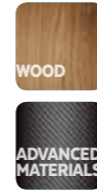

AVAILABLE WITH



## LAYOUT

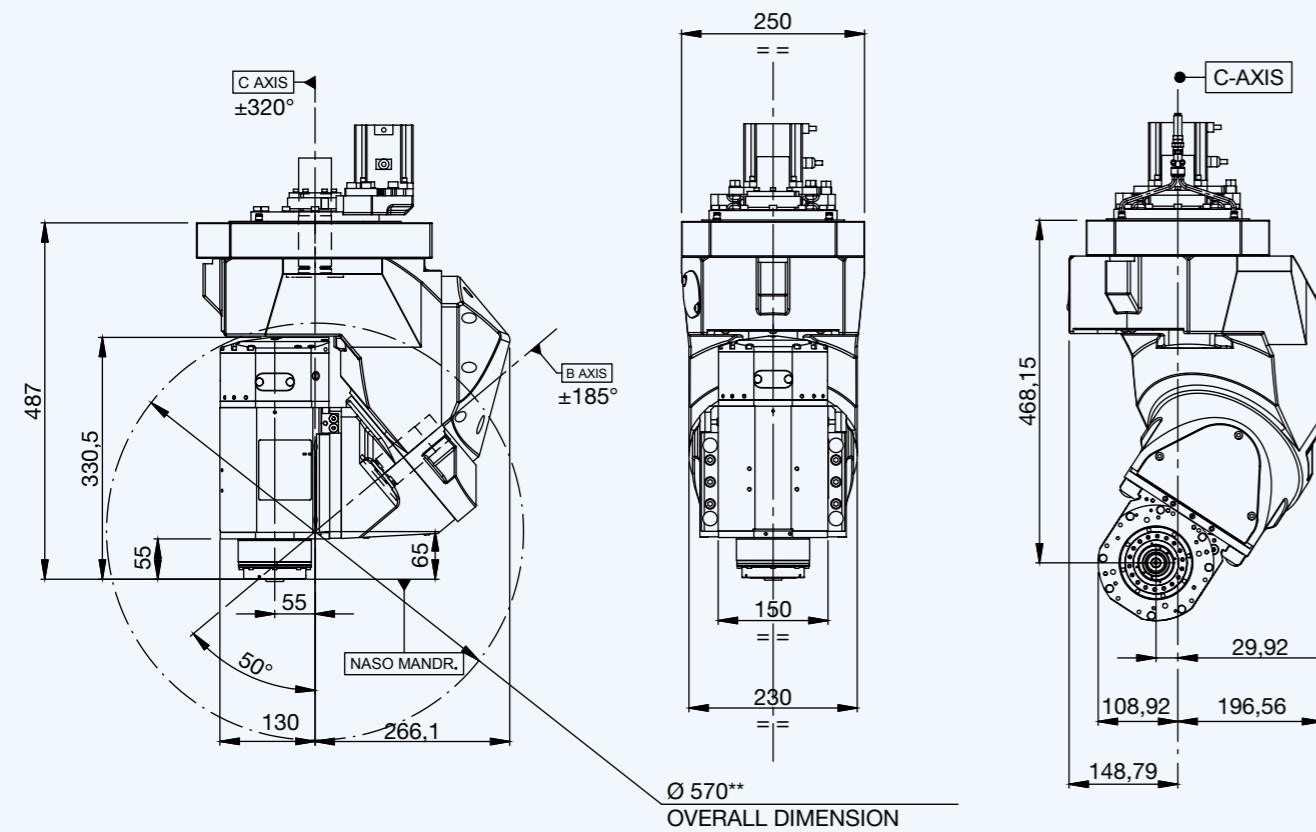

## OPTIONALS DELL'ELETTROMANDRINO / ELECTROSPINDLE OPTIONS

- Naso lungo / Long nose
- HSK 63E
- HSK 63A
- Monitoraggio temperatura cuscinetti / Temperature monitoring of bearings
- Misuratore di velocità / Speed monitoring
- Sensori di vibrazione / Vibration sensor
- Encoder

## SPECIFICHE TECNICHE / TECHNICAL SPECIFICATIONS

\*Sono disponibili altre marche di motorizzazioni a richiesta  
\*Other engine brands are available on demand

	ASSE B / B AXIS	ASSE C / C AXIS
Servomotore / Servomotor	Yaskawa*	Yaskawa*
Potenza servomotore / Servomotor power	0,4 kW	0,4 kW
Encoder servomotore / Servomotor encoder	Assoluto Absolute 20 Bit	Assoluto Absolute 20 Bit
Riduttore / Gearbox	Harmonic Drive	Harmonic Drive
Coppia di stallo / Stall torque	320 Nm	320 Nm
Coppia di picco / Peak torque	570 Nm	570 Nm
Max rotazione asse / Max axis rotation	±185°	±320°
Freni meccanici / Mechanical blocking of axes	No	Si / Yes
Velocità posizionamento max / Max. positioning speed	7.000°/'	7.000°/'
Precisione di posizionamento assi / Axis positioning accuracy	1 arcmin	1 arcmin
Peso / Weight		100 kg

## ELETTROMANDRINI DISPONIBILI / AVAILABLE ELECTROSPINDLES

PX-2 10/7 24 63F NC

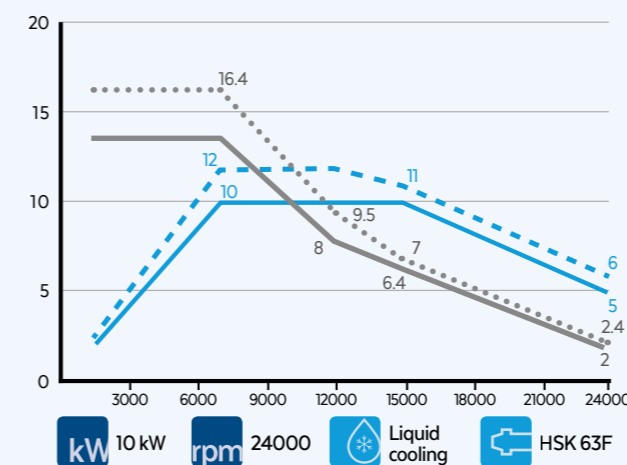

PX-2 12/12 24 63F NC

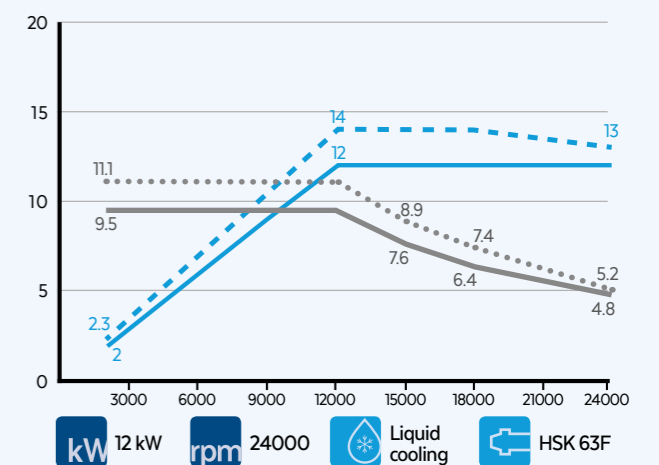

PX-2 15/12 24 63F NC

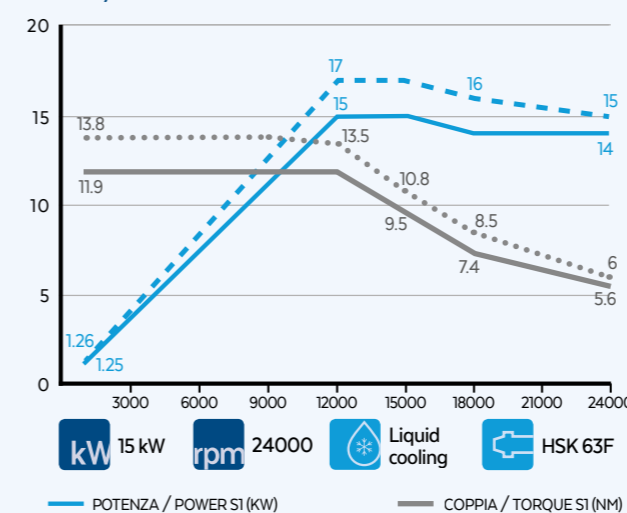

\*\* Per altri motori +X mm / For other motors +X mm

# SERIE ORBITAL ORBITAL K Plus



AVAILABLE WITH



## LAYOUT

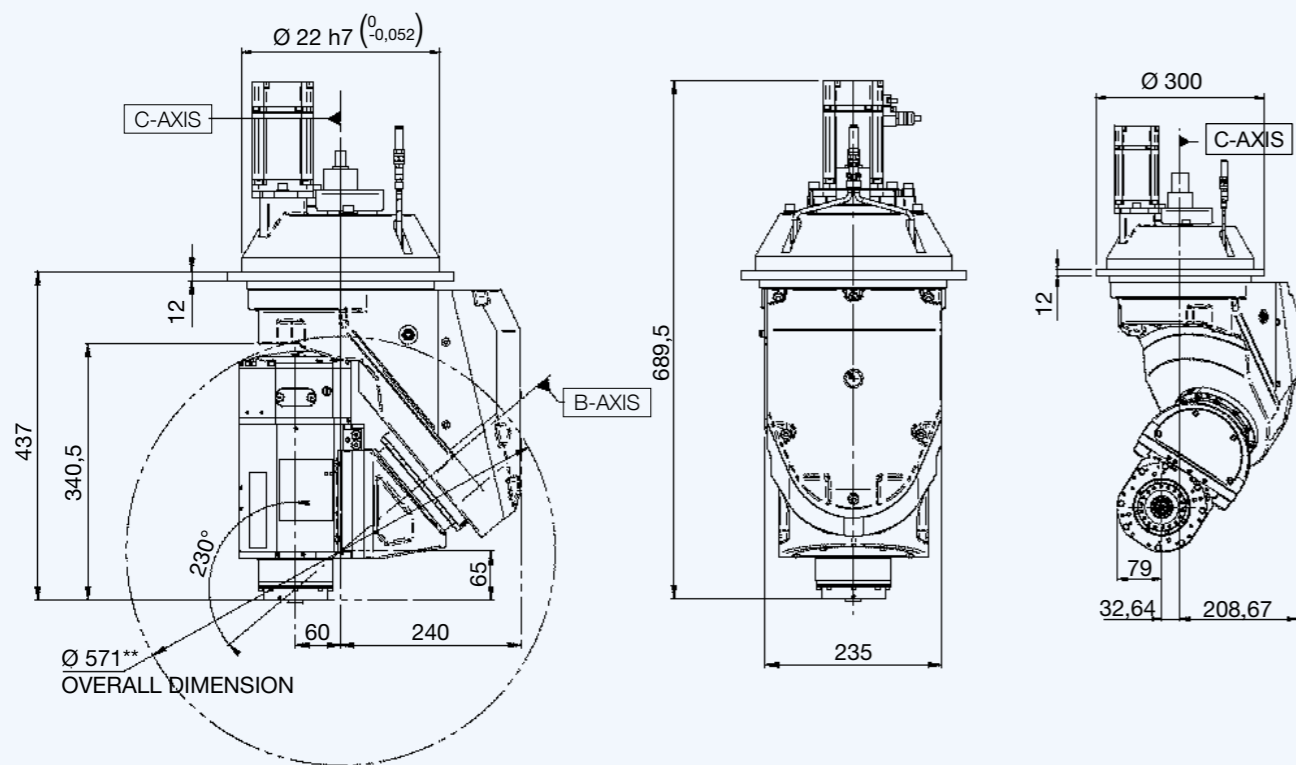

## OPTIONALS DELL'ELETTROMANDRINO / ELECTROSPINDLE OPTIONS

- Naso lungo / Long nose
- HSK 63E
- HSK 63A
- Monitoraggio temperatura cuscinetti / Temperature monitoring of bearings
- Misuratore di velocità / Speed monitoring
- Sensori di vibrazione / Vibration sensor
- Encoder

## SPECIFICHE TECNICHE / TECHNICAL SPECIFICATIONS

\*Sono disponibili altre marche di motorizzazioni a richiesta  
\*Other engine brands are available on demand

	ASSE B / B AXIS	ASSE C / C AXIS
Servomotore / Servomotor	Yaskawa*	Yaskawa*
Potenza servomotore / Servomotor power	0,4 kW	0,65 kW
Encoder servomotore / Servomotor encoder	Assoluto Absolute 20 Bit	Assoluto Absolute 20 Bit
Riduttore / Gearbox	Sumitomo	Sumitomo
Coppia di stallo / Stall torque	260 Nm	320 Nm
Coppia di picco / Peak torque	570 Nm	1030 Nm
Max rotazione asse / Max axis rotation	$\pm 185^\circ$	$\pm 320^\circ$
Freni meccanici / Mechanical blocking of axes	No	Si Yes
Velocità posizionamento max / Max. positioning speed	8.000°/'	10.000°/'
Velocità di lavoro max / Max. operating speed	4.800°/'	6.700°/'
Precisione di posizionamento assi / Axis positioning accuracy	1 arcmin	1 arcmin
Peso / Weight		90 kg

## ELETTROMANDRINI DISPONIBILI / AVAILABLE ELECTROSPINDLES

PX-2 13/7 24 63F NC

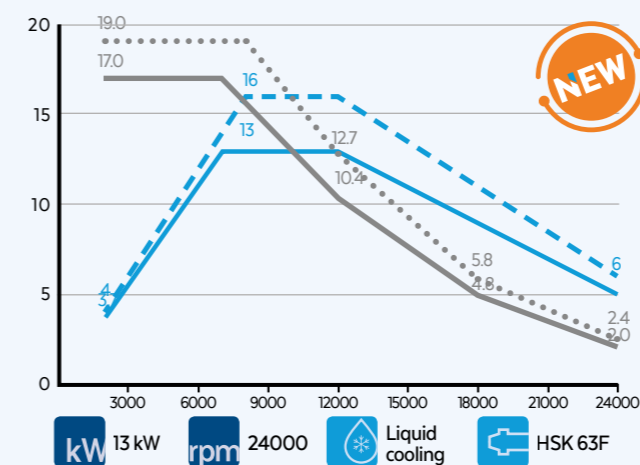

PX-2 12/12 24 63F NC

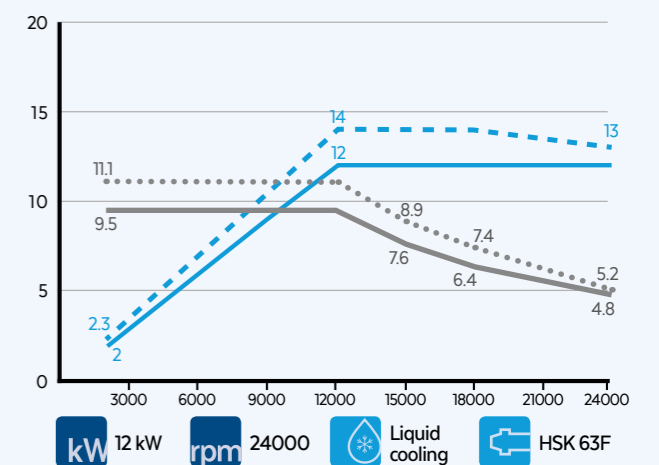

PX-2 15/12 24 63F NC

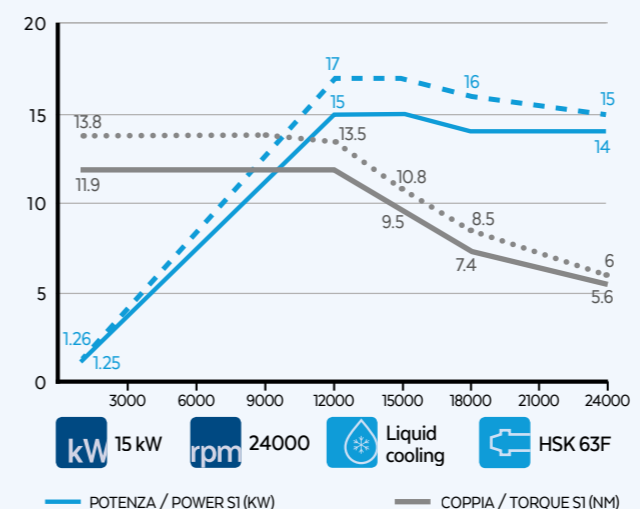

— POTENZA / POWER SI (kW)    - - - COPPIA / TORQUE SI (NM)  
 - - - POTENZA / POWER S6 50% (kW)    ..... COPPIA / TORQUE S6 50% (NM)

# SERIE ORBITAL ORBITAL H

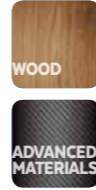

AVAILABLE WITH



## LAYOUT

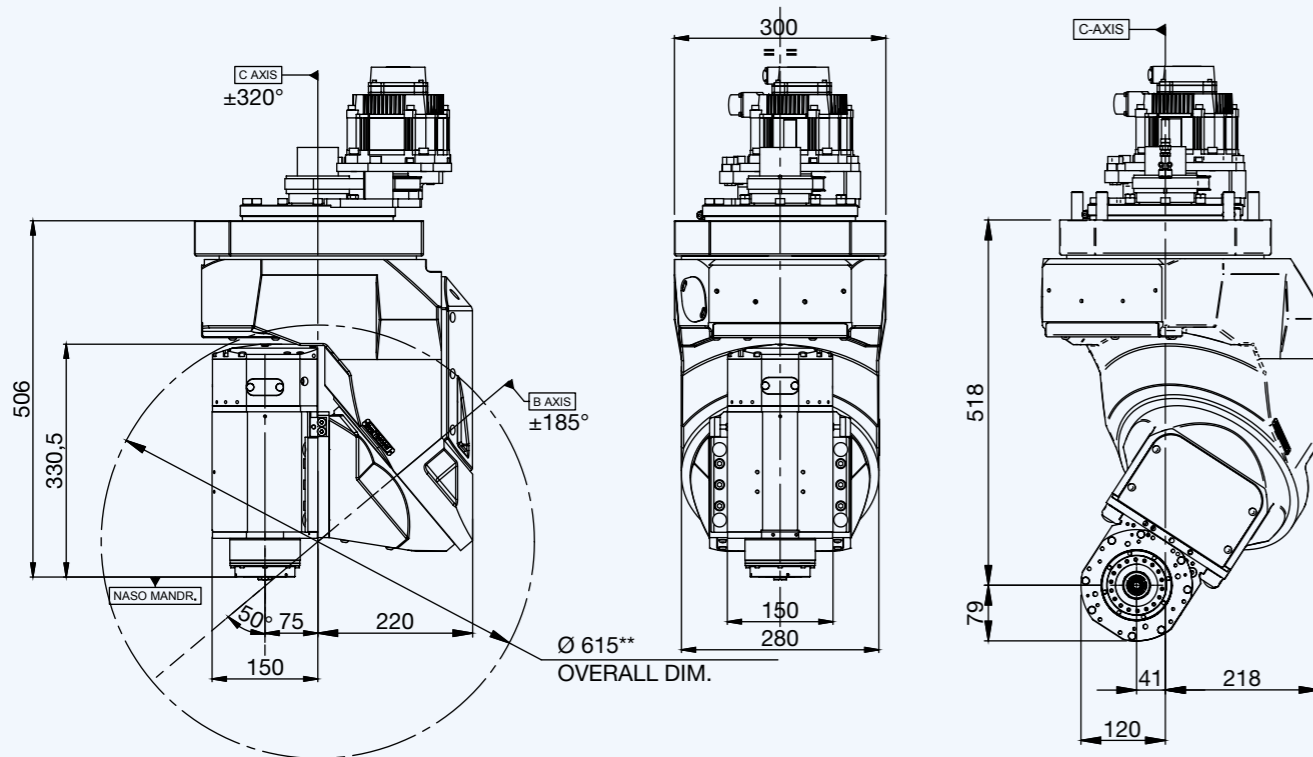

## OPTIONALS DELL'ELETTROMANDRINO / ELECTROSPINDLE OPTIONS

- Naso lungo / Long nose
- HSK 63E
- HSK 63A (Standard on 20 kW)
- Monitoraggio temperatura cuscinetti / Temperature monitoring of bearings
- Misuratore di velocità / Speed monitoring
- Sensori di vibrazione / Vibration sensor
- Encoder

\*\* Per altri motori +X mm / For other motors +X mm

## SPECIFICHE TECNICHE / TECHNICAL SPECIFICATIONS

\*Sono disponibili altre marche di motorizzazioni a richiesta  
\*Other engine brands are available on demand

	ASSE B / B AXIS	ASSE C / C AXIS
Servomotore / Servomotor	Yaskawa*	Yaskawa*
Potenza servomotore / Servomotor power	0,75 kW	0,85 kW
Encoder servomotore / Servomotor encoder	Assoluto Absolute 20 Bit	Assoluto Absolute 20 Bit
Riduttore / Gearbox	Sumitomo	Harmonic Drive
Coppia di stallo / Stall torque	320 Nm	670 Nm
Coppia di picco / Peak torque	740 Nm	980 Nm
Max rotazione asse / Max axis rotation	±185°	±320°
Freni meccanici / Mechanical blocking of axes	Si Yes	Si Yes
Velocità posizionamento max / Max. positioning speed	10.000°/'	11.500°/'
Precisione di posizionamento assi / Axis positioning accuracy	1 arcmin	1 arcmin
Peso / Weight		140 kg

## ELETTROMANDRINI DISPONIBILI / AVAILABLE ELECTROSPINDLES

PX-2 10/7 24 63F NC

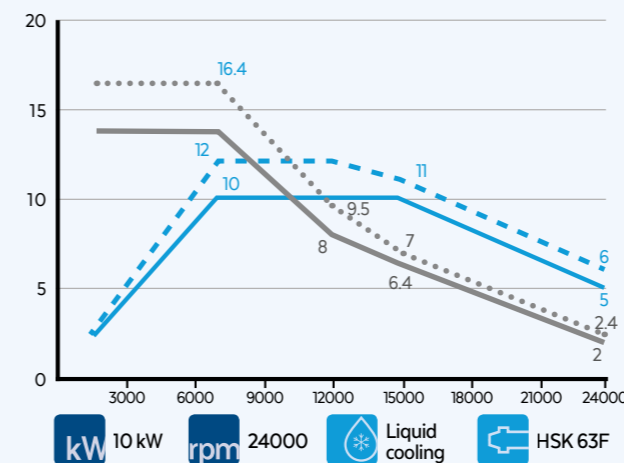

PX-2 15/12 24 63F NC

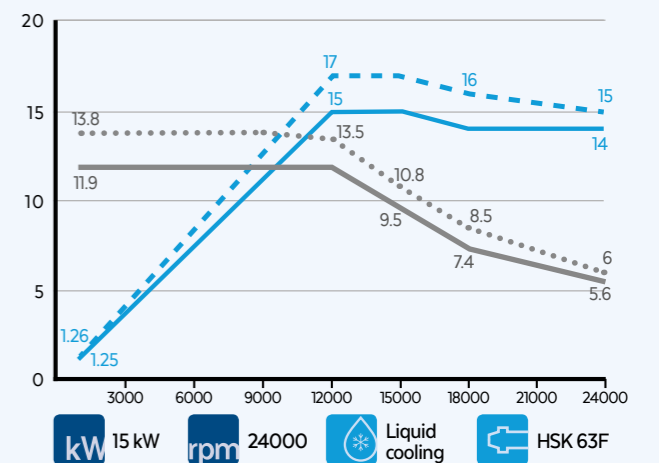

PX-2 18/12 24 63F NC

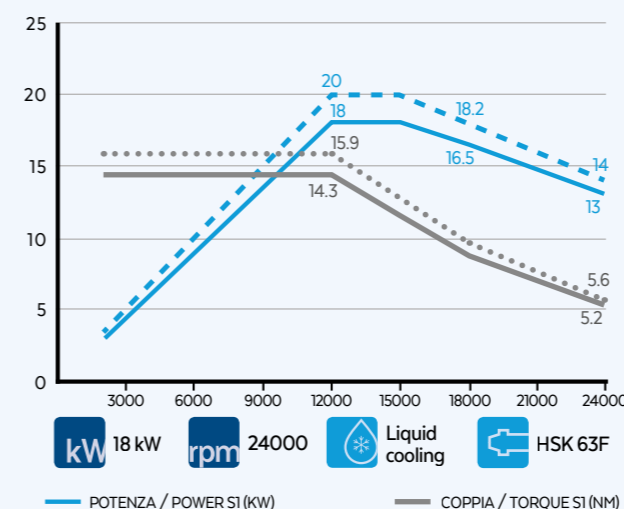

PX-2 20/10 24 63A NC ES SYNCHRONOUS

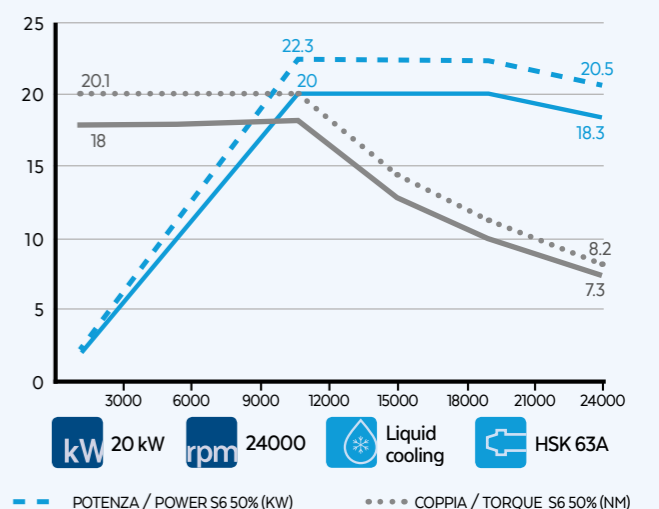



# SERIE TILT TILT J



ADVANCED MATERIALS

PLASTIC

AVAILABLE WITH



## LAYOUT

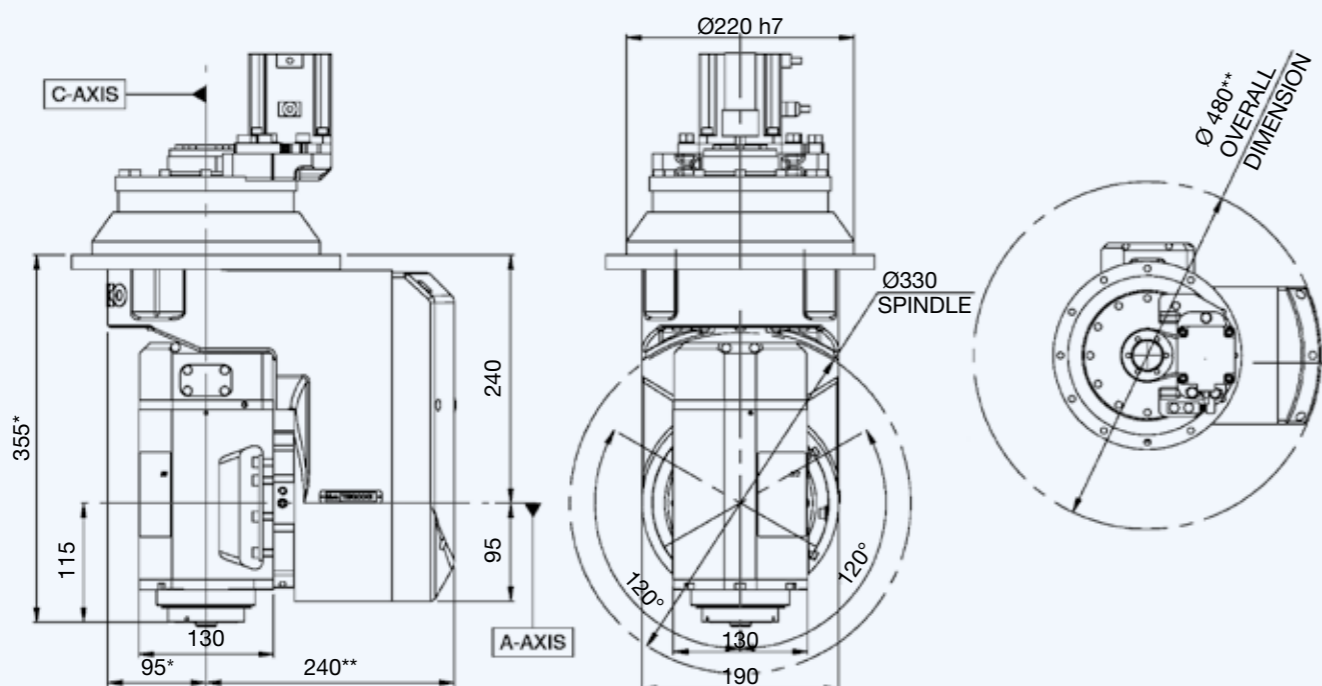

## OPTIONALS DELL'ELETTROMANDRINO / ELECTROSPINDLE OPTIONS

- Monitoraggio temperatura cuscinetti / Temperature monitoring of bearings
- Misuratore di velocità / Speed monitoring
- Sensori di vibrazione / Vibration sensor
- Encoder\*

## SPECIFICHE TECNICHE / TECHNICAL SPECIFICATIONS

\*Sono disponibili altre marche di motorizzazioni a richiesta  
\*Other engine brands are available on demand

	ASSE A / A AXIS	ASSE C / C AXIS
Servomotore / Servomotor	Yaskawa*	Yaskawa*
Potenza servomotore / Servomotor power	0,40 kW	0,40 kW
Encoder servomotore / Servomotor encoder	Assoluto Absolute 20 Bit	Assoluto Absolute 20 Bit
Riduttore / Gearbox	Harmonic Drive	Harmonic Drive
Coppia di stallo / Stall torque	380 Nm	380 Nm
Coppia di picco / Peak torque	570 Nm	570 Nm
Max rotazione asse / Max axis rotation	±120°	±320°
Freni meccanici / Mechanical blocking of axes	No	No
Velocità posizionamento max / Max. positioning speed	6.100°/'	6.100°/'
Precisione di posizionamento assi / Axis positioning accuracy	1 arcmin	1 arcmin
Peso / Weight		60 kg

## ELETTROMANDRINI DISPONIBILI / AVAILABLE ELECTROSPINDLES

QX-2 8.5/12 24 63F NC

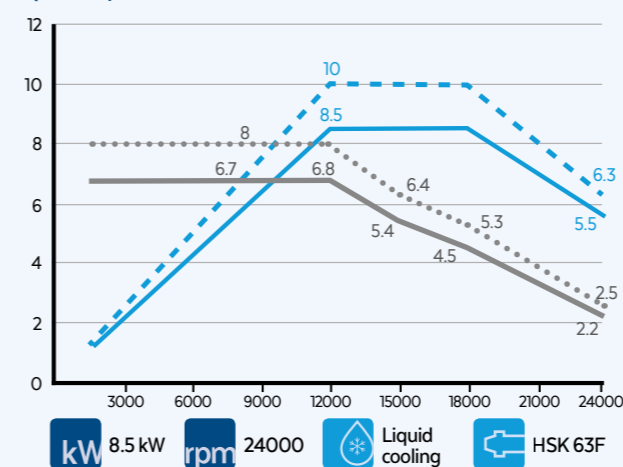

QX-2 10/12 24 63F NC

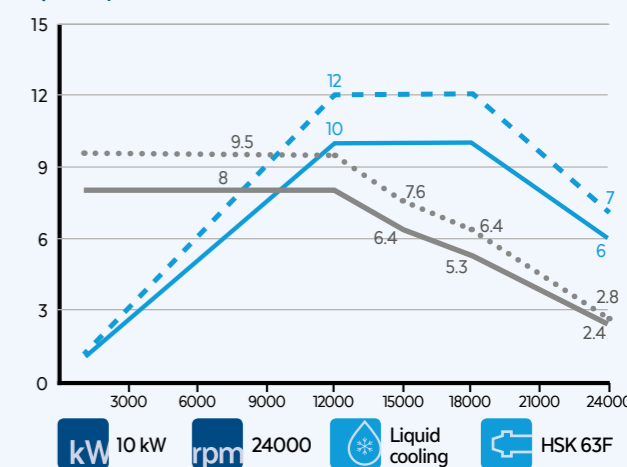

QX-2 11/12 24 63F NC

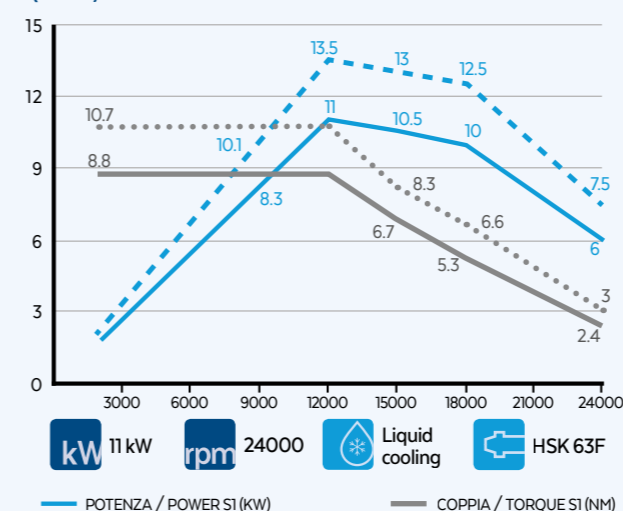

QX-1C 5/12 21 63F NC

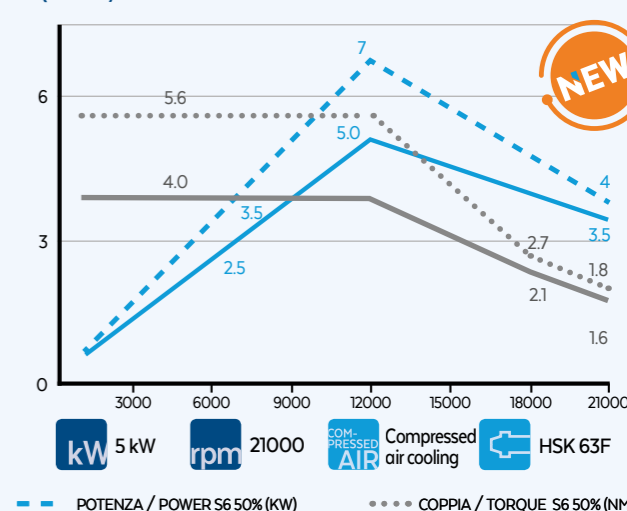

\*L'opzionale encoder comporta un aumento di 25 mm rispetto alla quota riportata nello schema / When the unit is with encoder the quote increases by 25 mm from the one represented in the plan  
\*\* Per altri motori +X mm / For other motors +X mm

# SERIE TILT TILT J High Speed



AVAILABLE WITH



## LAYOUT

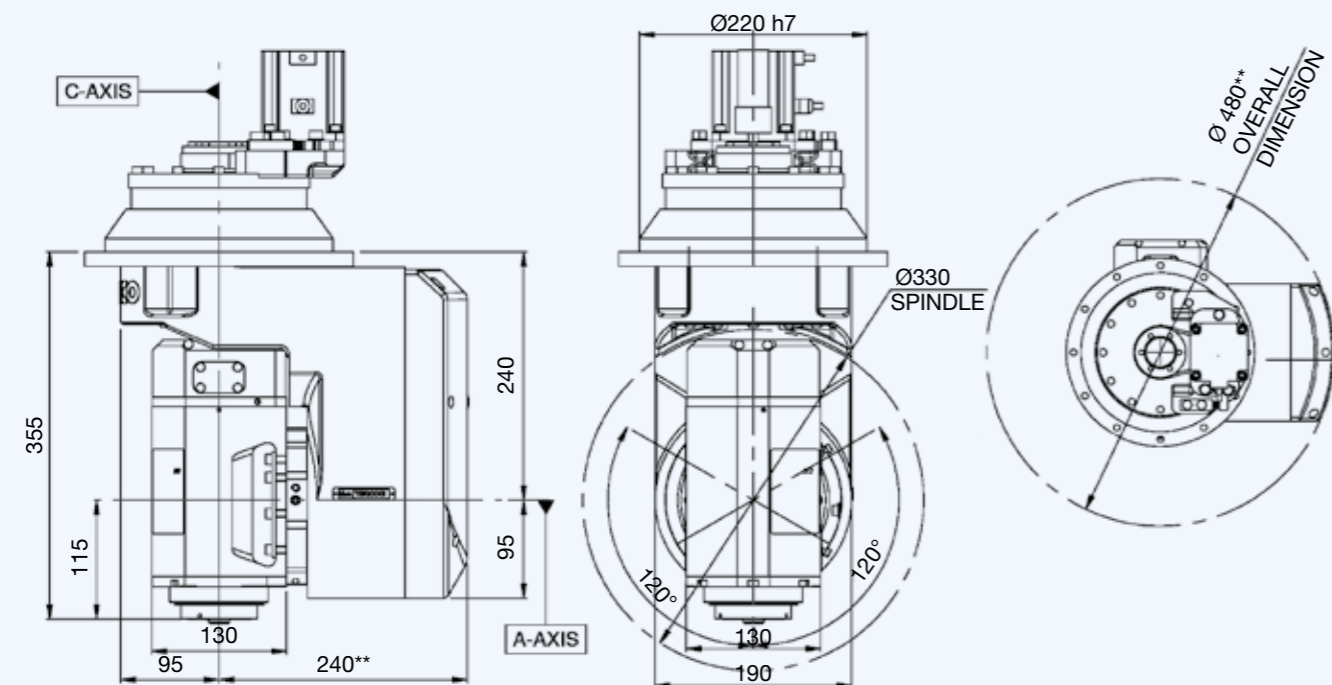

## OPTIONALS DELL'ELETTROMANDRINO / ELECTROSPINDLE OPTIONS

- Monitoraggio temperatura cuscinetti / Temperature monitoring of bearings
- Misuratore di velocità / Speed monitoring
- Sensori di vibrazione / Vibration sensor
- Encoder

## SPECIFICHE TECNICHE / TECHNICAL SPECIFICATIONS

\*Sono disponibili altre marche di motorizzazioni a richiesta  
\*Other engine brands are available on demand

	ASSE A / A AXIS	ASSE C / C AXIS
Servomotore / Servomotor	Yaskawa*	Yaskawa*
Potenza servomotore / Servomotor power	0,40 kW	0,40 kW
Encoder servomotore / Servomotor encoder	Assoluto Absolute 20 Bit	Assoluto Absolute 20 Bit
Riduttore / Gearbox	Harmonic Drive	Harmonic Drive
Coppia di stallo / Stall torque	380 Nm	380 Nm
Coppia di picco / Peak torque	570 Nm	570 Nm
Max rotazione asse / Max axis rotation	±120°	±320°
Freni meccanici / Mechanical blocking of axes	No	No
Velocità posizionamento max / Max. positioning speed	6.100°/'	6.100°/'
Precisione di posizionamento assi / Axis positioning accuracy	1 arcmin	1 arcmin
Peso / Weight		60 kg

## ELETTROMANDRINI DISPONIBILI / AVAILABLE ELECTROSPINDLES

QX-2 8/15 36 40E NC

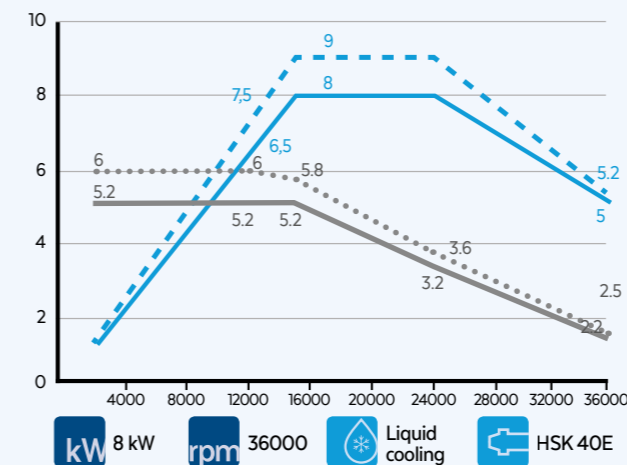

QX-2 8/15 40 32E NC

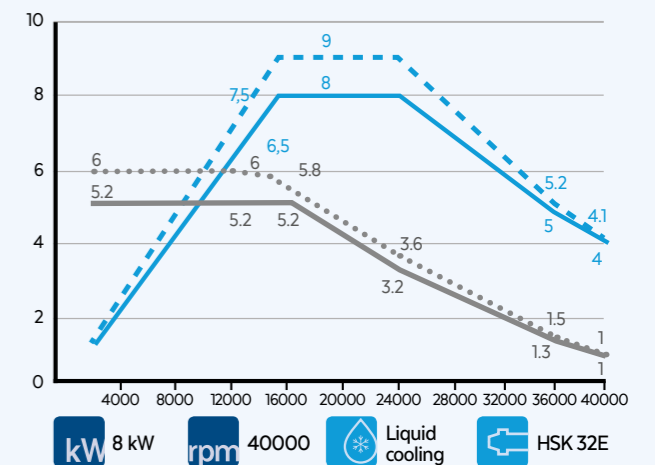

— POTENZA / POWER SI (kW)    — COPPIA / TORQUE SI (NM)    - - - POTENZA / POWER S6 50% (kW)    ···· COPPIA / TORQUE S6 50% (NM)

\*\* Per altri motori +X mm / For other motors +X mm

# SERIE TILT TILT K



AVAILABLE WITH



## LAYOUT

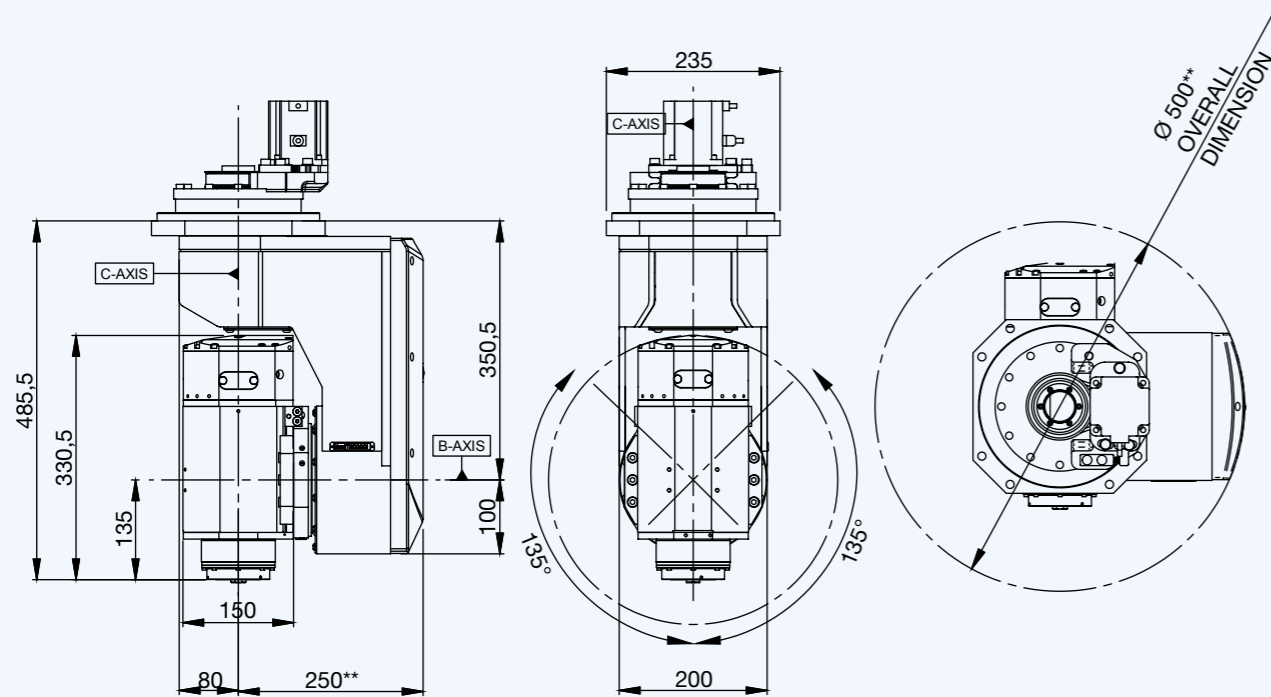

## OPTIONALS DELL'ELETTROMANDRINO / ELECTROSPINDLE OPTIONS

- Naso lungo / Long nose
- HSK 63E
- HSK 63A
- Monitoraggio temperatura cuscinetti / Temperature monitoring of bearings
- Misuratore di velocità / Speed monitoring
- Sensori di vibrazione / Vibration sensor
- Encoder

\*\* Per altri motori +X mm / For other motors +X mm

## SPECIFICHE TECNICHE / TECHNICAL SPECIFICATIONS

\*Sono disponibili altre marche di motorizzazioni a richiesta  
\*Other engine brands are available on demand

	ASSE A / A AXIS	ASSE C / C AXIS
Servomotore / Servomotor	Yaskawa*	Yaskawa*
Potenza servomotore / Servomotor power	0,40 kW	0,40 kW
Encoder servomotore / Servomotor encoder	Assoluto Absolute 20 Bit	Assoluto Absolute 20 Bit
Riduttore / Gearbox	Harmonic Drive	Harmonic Drive
Coppia di stallo / Stall torque	380 Nm	380 Nm
Coppia di picco / Peak torque	570 Nm	570 Nm
Max rotazione asse / Max axis rotation	±135°	±320°
Freni meccanici / Mechanical blocking of axes	No	No
Velocità posizionamento max / Max. positioning speed	6.100°/'	6.100°/'
Precisione di posizionamento assi / Axis positioning accuracy	1 arcmin	1 arcmin
Peso / Weight		100 kg

## ELETTROMANDRINI DISPONIBILI / AVAILABLE ELECTROSPINDLES

PX-2 10/7 24 63F NC

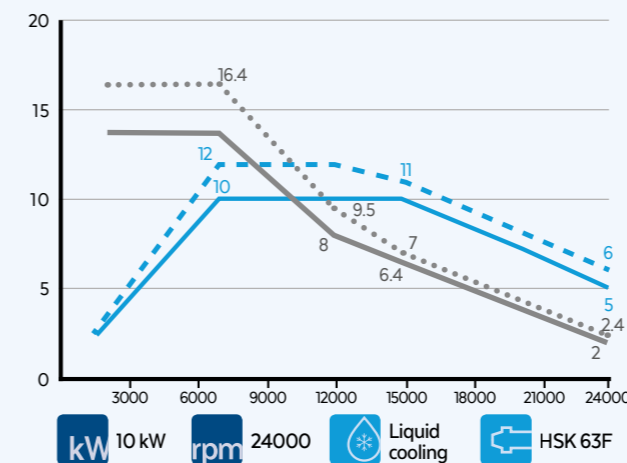

PX-2 12/12 24 63F NC

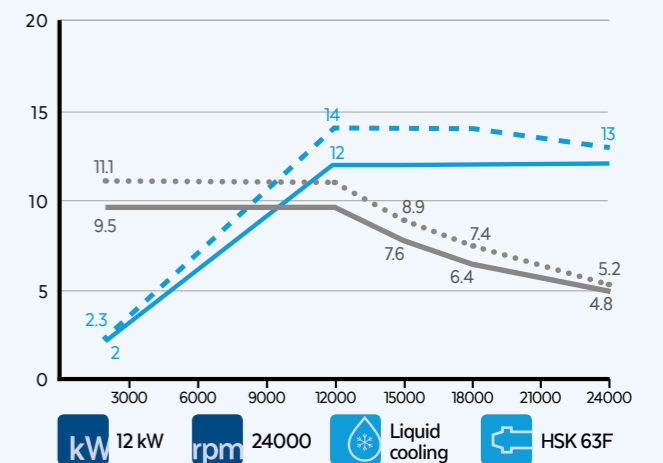

PX-2 15/12 24 63F NC

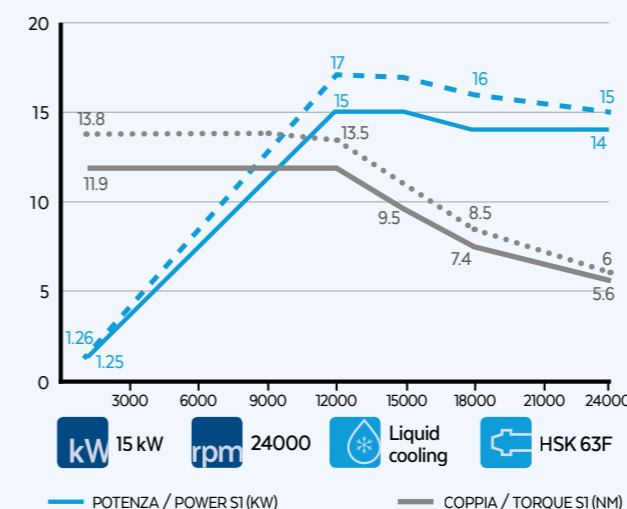

# SERIE TILT TILT K Plus



AVAILABLE WITH



## LAYOUT

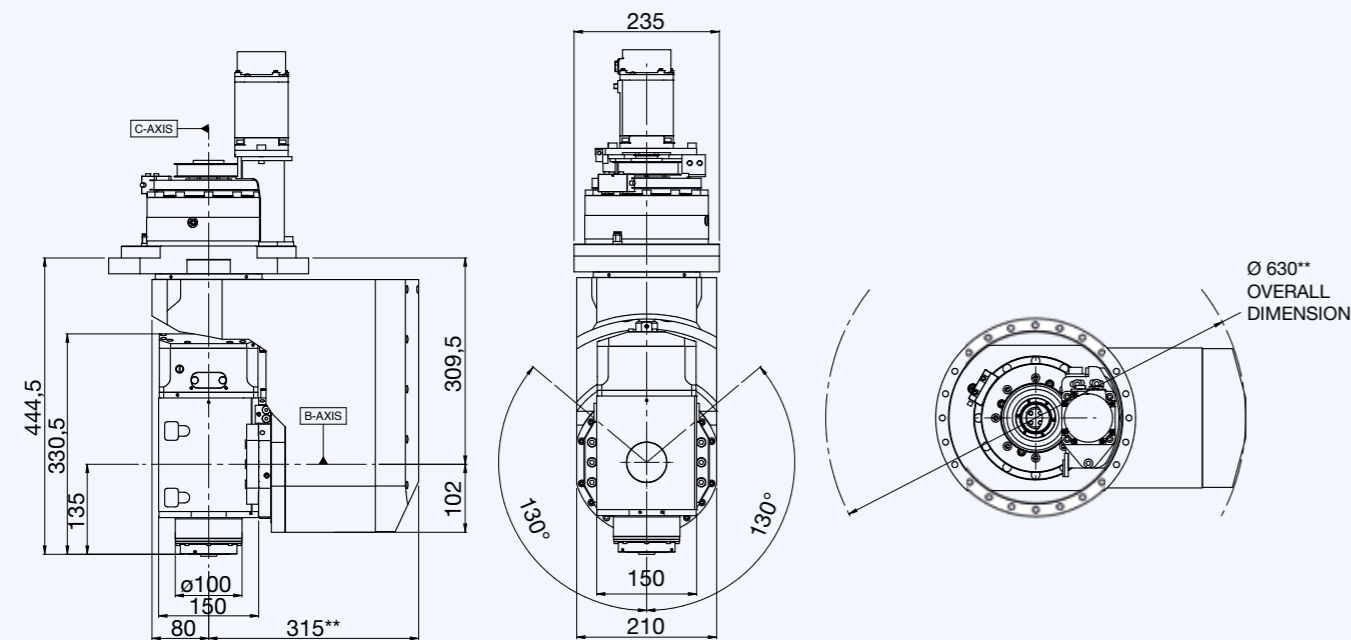

## OPTIONALS DELL'ELETTROMANDRINO / ELECTROSPINDLE OPTIONS

- HSK 63F
- HSK 63A
- Air tool
- Oil mist/MQL
- Monitoraggio temperatura cuscinetti / Temperature monitoring of bearings
- Sensore di vibrazione / Vibration sensor
- Temperature sensor
- Speed monitoring
- Encoder 1Vpp o TTL

## SPECIFICHE TECNICHE / TECHNICAL SPECIFICATIONS

\*Sono disponibili altre marche di motorizzazioni a richiesta  
\*Other engine brands are available on demand

	ASSE A / A AXIS	ASSE C / C AXIS
Servomotore / Servomotor type	Yaskawa*	Yaskawa*
Potenza servomotore / Servomotor power	0,4 kW	0,65 kW
Encoder servomotore / Servomotor encoder	Assoluto Absolute 20 Bit	Assoluto Absolute 20 Bit
Riduttore / Gearbox	Sumitomo	Sumitomo
Coppia di stallo / Stall torque	350 Nm	503 Nm
Coppia di picco / Peak torque	1030 Nm	1030 Nm
Max rotazione asse / Max. axis rotation	±130°	±320°
Velocità posizionamento max / Max. positioning speed	6.700°/'	7.500°/'
Freni meccanici / Mechanical blocking of axes	No	No
Precisione / Accuracy	±30 arsec	±30 arsec
Repetibilità / Repeatability	±10 arsec	±10 arsec
Utenze / External air connection		n2
Peso / Weight		100 kg

## ELETTROMANDRINI DISPONIBILI / AVAILABLE ELECTROSPINDLES

HX-2 13/7 24 63F NC

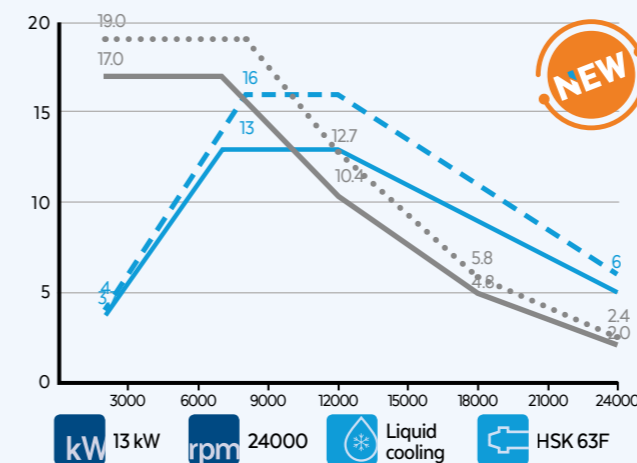

HX-2 12/12 24 63F NC

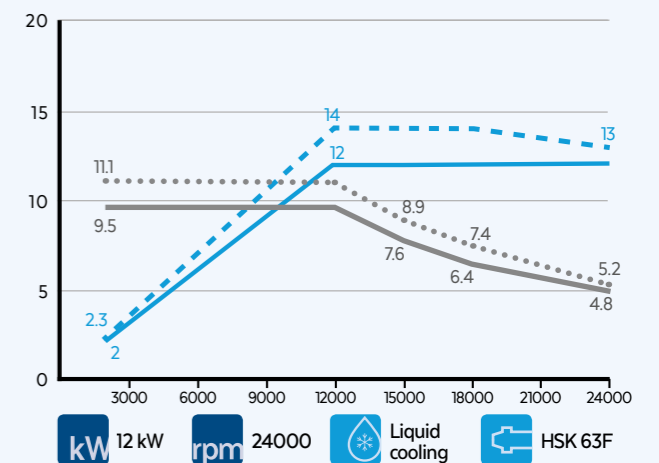

HX-2 15/12 24 63F NC

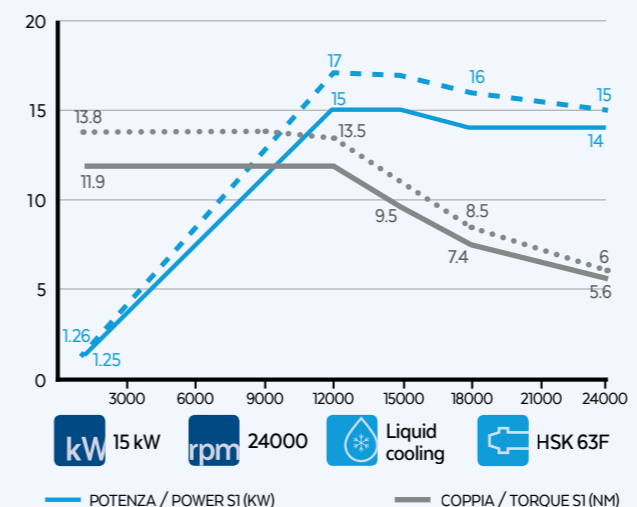

# SERIE TILT TILT H



- LIGHT ALLOYS
- ADVANCED MATERIALS
- PLASTIC

AVAILABLE WITH



## LAYOUT

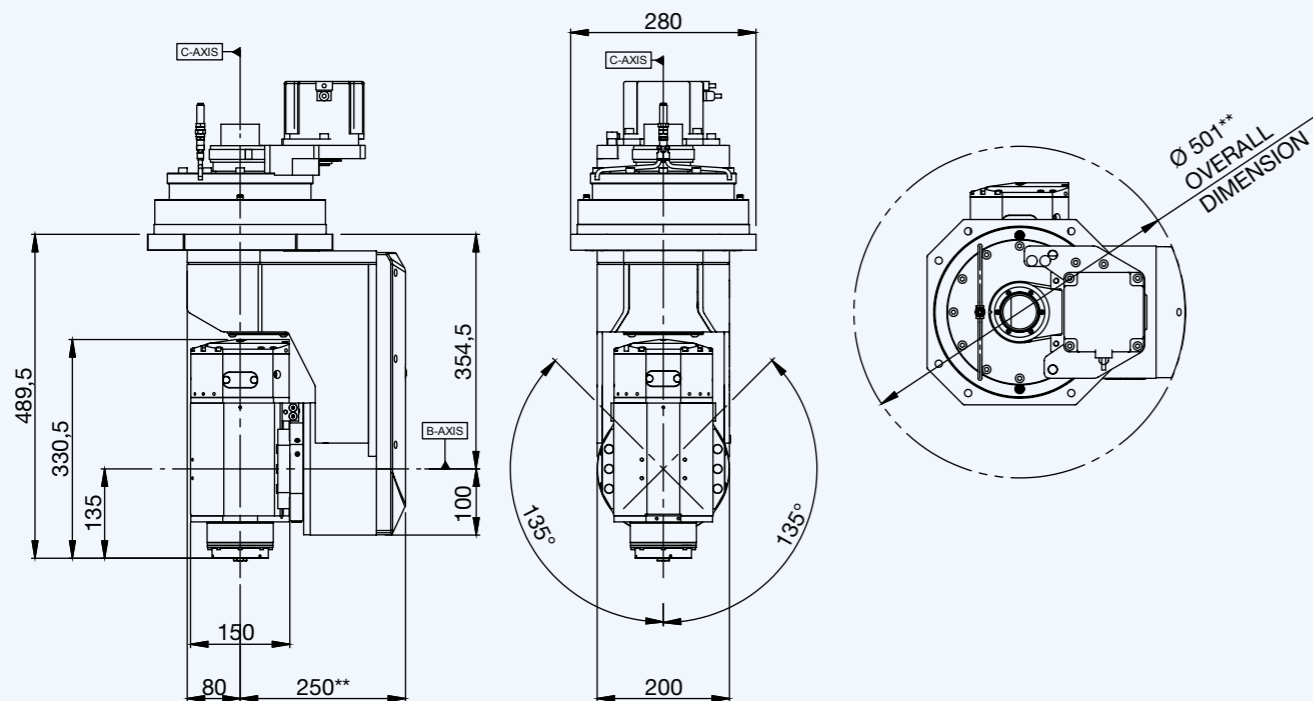

## OPTIONALS DELL'ELETTROMANDRINO / ELECTROSPINDLE OPTIONS

- Naso lungo / Long nose
- HSK 63E
- HSK 63A (Standard on 20 kw)
- Monitoraggio temperatura cuscinetti / Temperature monitoring of bearings
- Misuratore di velocità / Speed monitoring
- Sensori di vibrazione / Vibration sensor
- Encoder

## SPECIFICHE TECNICHE / TECHNICAL SPECIFICATIONS

\*Sono disponibili altre marche di motorizzazioni a richiesta  
\*Other engine brands are available on demand

	ASSE A / A AXIS	ASSE C / C AXIS
Servomotore / Servomotor	Yaskawa*	Yaskawa*
Potenza servomotore / Servomotor power	0,40 kW	0,75 kW
Encoder servomotore / Servomotor encoder	Assoluto Absolute 20 Bit	Assoluto Absolute 20 Bit
Riduttore / Gearbox	Harmonic Drive	Harmonic Drive
Coppia di stallo / Stall torque	380 Nm	460 Nm
Coppia di picco / Peak torque	570 Nm	980 Nm
Max rotazione asse / Max axis rotation	$\pm 135^\circ$	$\pm 320^\circ$
Freni meccanici / Mechanical blocking of axes	Si Yes	Si Yes
Velocità posizionamento max / Max. positioning speed	6.100°/'	9.300°/'
Precisione di posizionamento assi / Axis positioning accuracy	1 arcmin	1 arcmin
Peso / Weight		120 kg

## ELETTROMANDRINI DISPONIBILI / AVAILABLE ELECTROSPINDLES

PX-2 10/7 24 63F NC

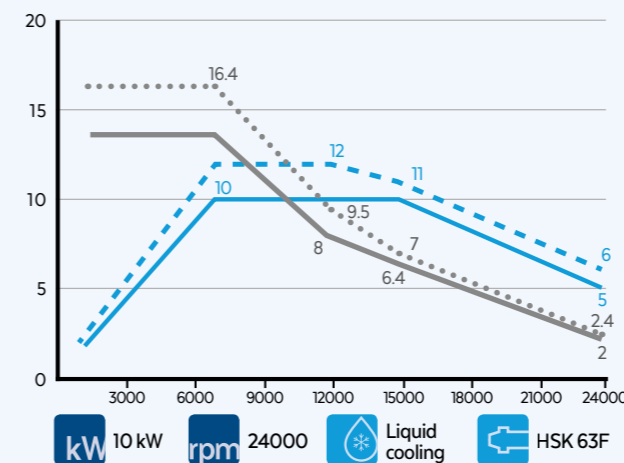

PX-2 15/12 24 63F NC

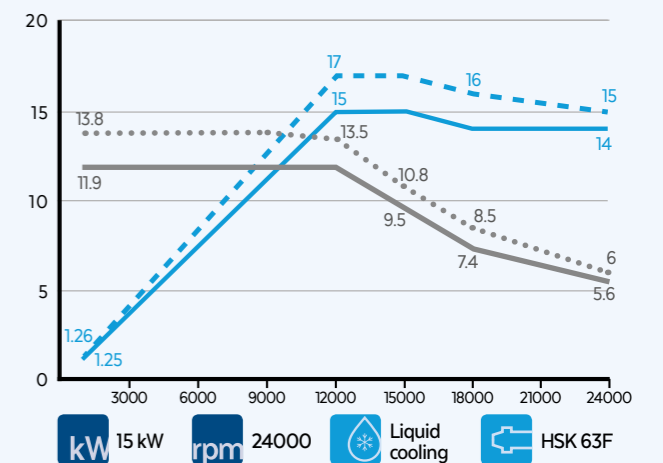

PX-2 18/12 24 63F NC

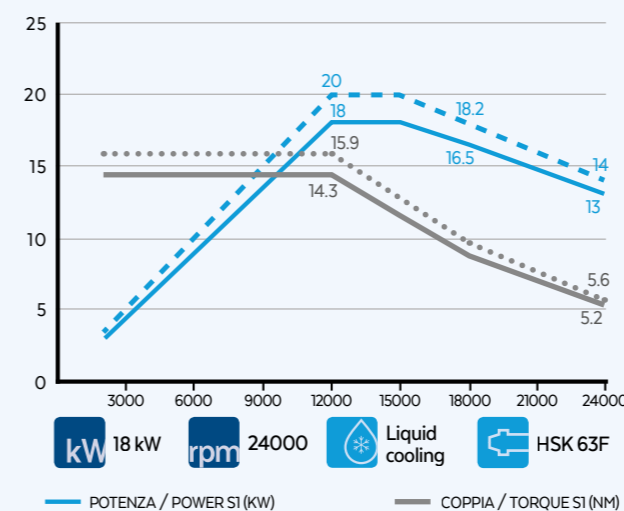

PX-2 20/10 24 63A NC ES SYNCHRONOUS

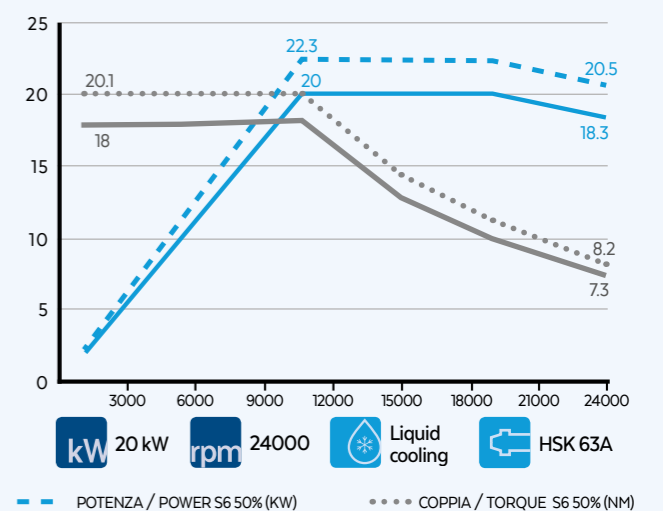

\*\* Per altri motori +X mm / For other motors +X mm

# SERIE TILT TILT H Plus



AVAILABLE WITH



## LAYOUT

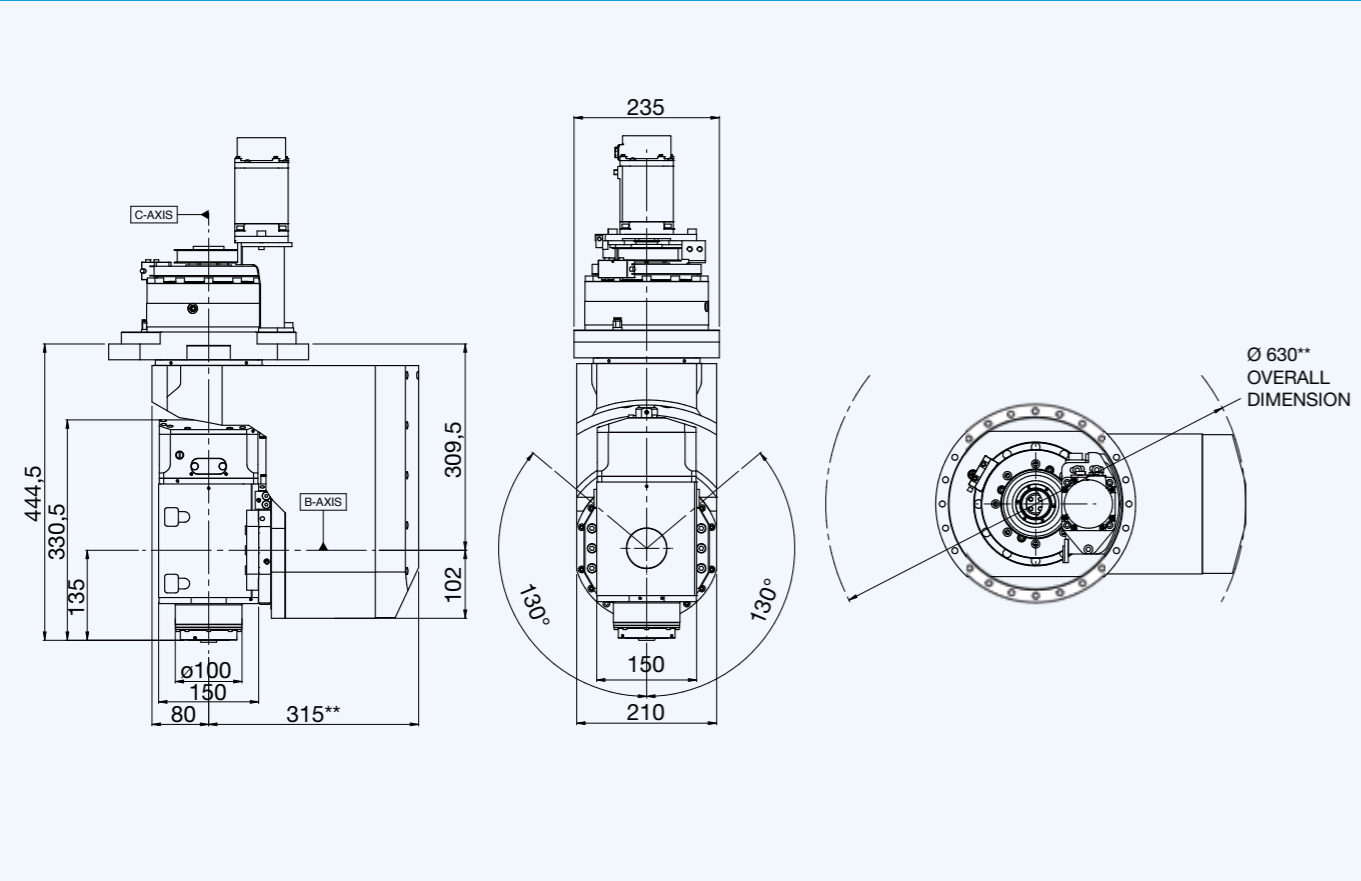

## OPTIONALS DELL'ELETTROMANDRINO / ELECTROSPINDLE OPTIONS

- HSK 63F
- HSK 63A
- Air tool
- Oil mist/MQL
- Monitoraggio temperatura cuscinetti  
Temperature monitoring of bearings
- Sensore di vibrazione  
Vibration sensor
- Temperature sensor
- Speed monitoring
- Encoder I1Vpp o TTL

\*\* Per altri motori +X mm / For other motors +X mm

## SPECIFICHE TECNICHE / TECHNICAL SPECIFICATIONS

\*Sono disponibili altre marche di motorizzazioni a richiesta  
\*Other engine brands are available on demand

	ASSE A / A AXIS	ASSE C / C AXIS
Servomotore / Servomotor type	Yaskawa*	Yaskawa*
Potenza servomotore / Servomotor power	0,4 kW	0,65 kW
Encoder servomotore / Servomotor encoder	Assoluto Absolute 20 Bit	Assoluto Absolute 20 Bit
Riduttore / Gearbox	Sumitomo	Sumitomo
Coppia di stallo / Stall torque	350 Nm	503 Nm
Coppia di picco / Peak torque	1030 Nm	1030 Nm
Max rotazione asse / Max. axis rotation	±130°	±320°
Velocità posizionamento max / Max. positioning speed	6.700°/'	7.500°/'
Freni meccanici / Holding brake	Si Yes	Si Yes
Encoder assi / Axis encoder	Si Yes	Si Yes
Precisione / Accuracy	±30 arsec (±15 arsec)*	±30 arsec (±15 arsec)*
Ripetibilità / Repeatability	±10 arsec (±5 arsec)*	±10 arsec (±5 arsec)*
Utenze / External air connection		n2
Peso / Weight		100 kg

\*Con encoder assi / With encoder axis

## ELETTROMANDRINI DISPONIBILI / AVAILABLE ELECTROSPINDLES

HX-2 13/7 24 63F NC

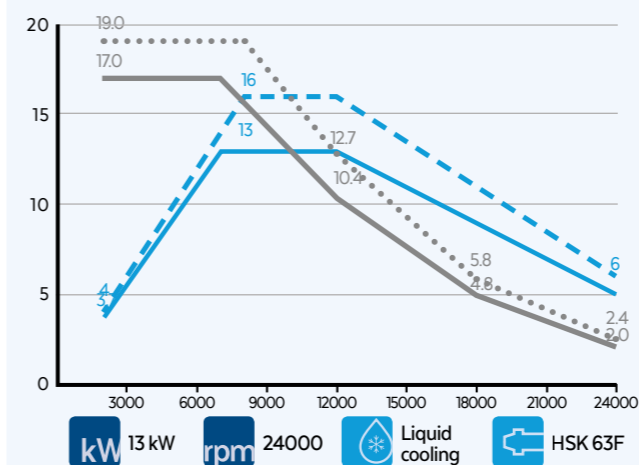

HX-2 15/12 24 63F NC

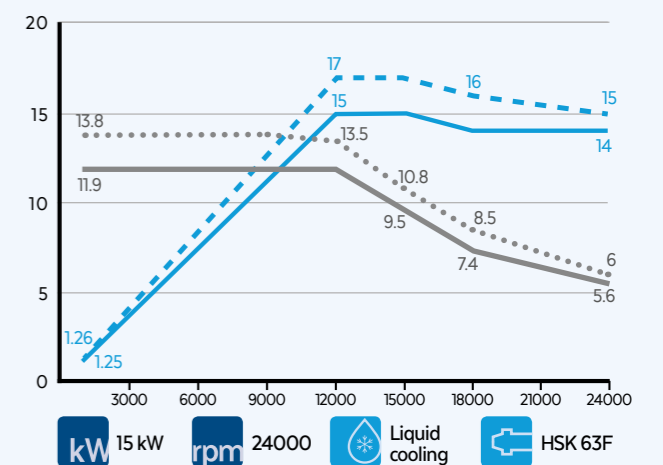

HX-2 18/12 24 63F NC

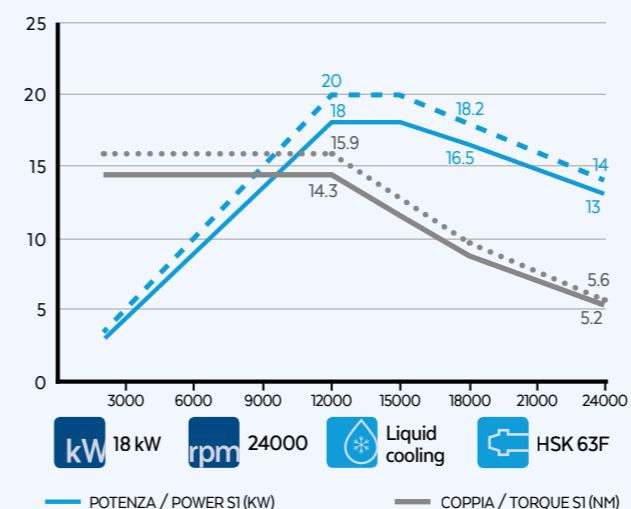

HX-2 20/10 24 63A NC ES SYNCHRONOUS

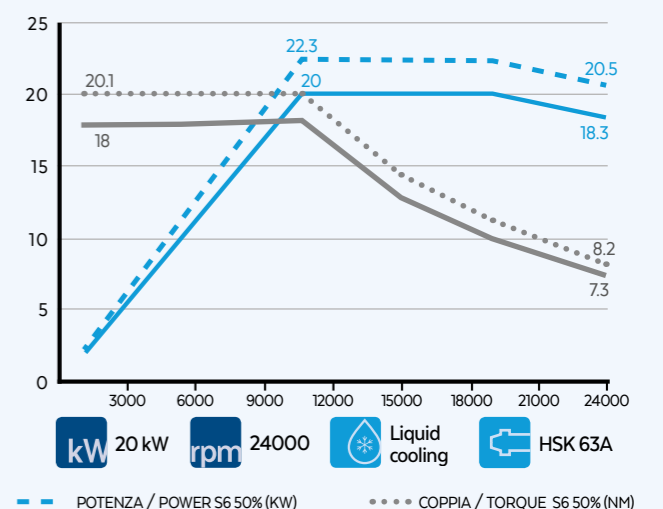

# SERIE TILT TILT VHT



- LIGHT ALLOYS
- ADVANCED MATERIALS
- PLASTIC
- WOOD

AVAILABLE WITH



## LAYOUT

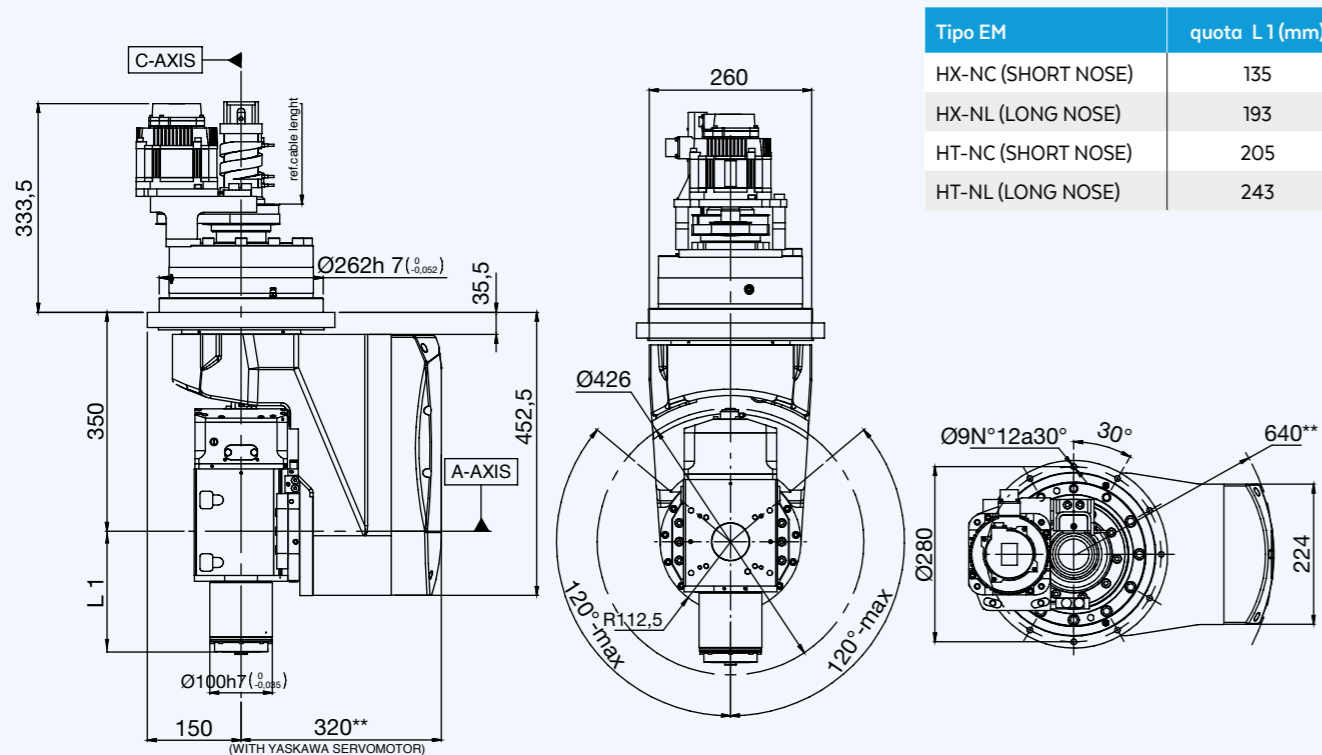

## OPTIONALS DELL'ELETTROMANDRINO / ELECTROSPINDLE OPTIONS

- Naso corto / Short nose
- HSK 63E
- HSK 63A
- Oil mist / MQL
- Monitoraggio temperatura cuscinetti / Temperature monitoring of bearings
- Misuratore di velocità / Speed monitoring
- Sensori di vibrazione / Vibration sensor
- Air tool

## SPECIFICHE TECNICHE / TECHNICAL SPECIFICATIONS

\*Sono disponibili altre marche di motorizzazioni a richiesta  
 \*Other engine brands are available on demand

	ASSE A / A AXIS	ASSE C / C AXIS
Servomotore / Servomotor	Yaskawa*	Yaskawa*
Potenza servomotore / Servomotor power	0,75 kW	0,85 kW
Encoder servomotore / Servomotor encoder	Assoluto Absolute 20 Bit	Assoluto Absolute 20 Bit
Riduttore / Gearbox	Sumitomo	Sumitomo
Coppia di stallo / Stall torque	425 Nm	635 Nm
Coppia di picco / Peak torque	1030 Nm	1962 Nm
Max rotazione asse / Max axis rotation	$\pm 120^{\circ}$	$\pm 320^{\circ}$
Velocità posizionamento max / Max. positioning speed	10.000°/'	12.500°/'
Freni meccanici / Mechanical blocking of axes	Si Yes	Si Yes
Encoder assi / Axis encoder optional	Si Yes (OPT)	Si Yes (OPT)
Precisione / Accuracy	$\pm 30$ arcsec ( $\pm 15$ arcsec)*	$\pm 30$ arcsec ( $\pm 15$ arcsec)*
Ripetibilità / Repeatability	$\pm 10$ arcsec ( $\pm 5$ arcsec)*	$\pm 10$ arcsec ( $\pm 5$ arcsec)*
UtENZE / External air connections		n2
Peso / Weight		150 kg

\*Con encoder assi / With encoder axis

## ELETTROMANDRINI DISPONIBILI / AVAILABLE ELECTROSPINDLES

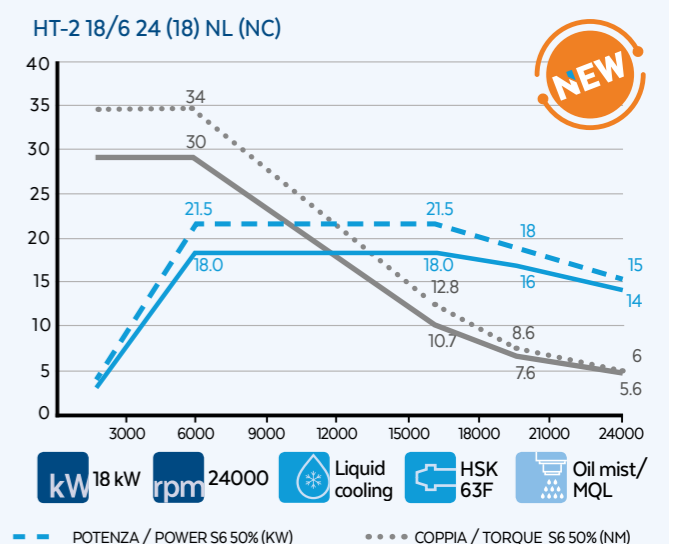
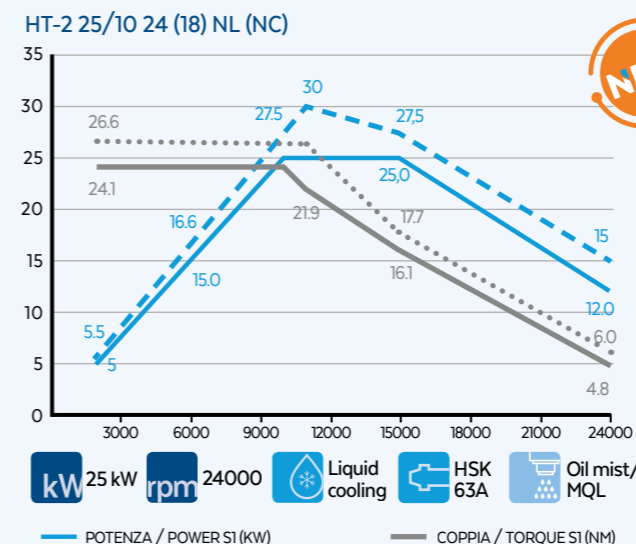
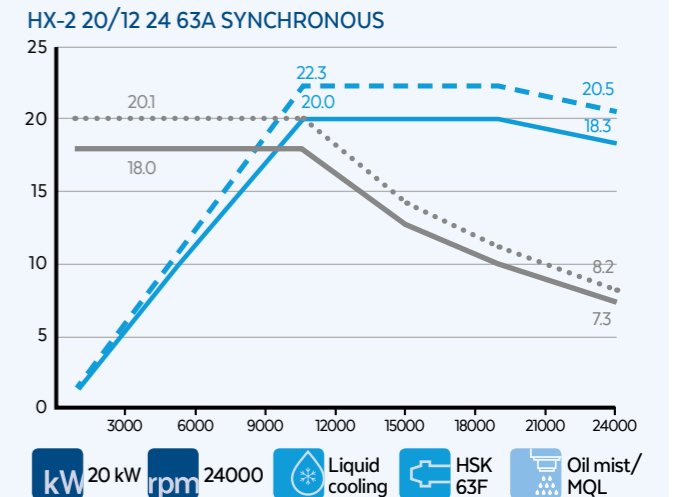
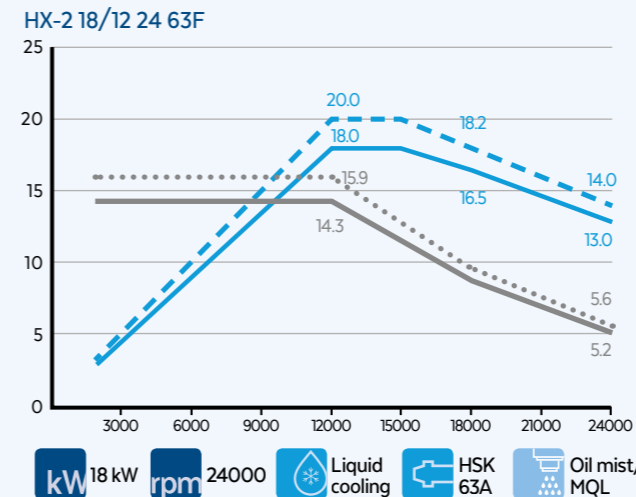

SERIE TILT  
TILT V QT

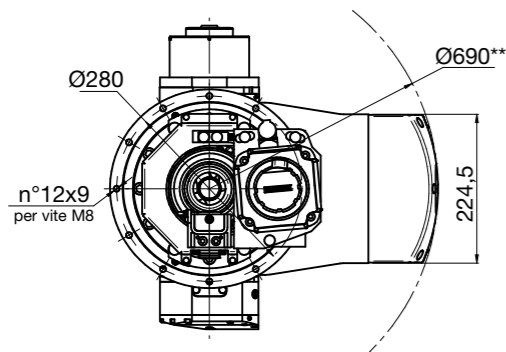
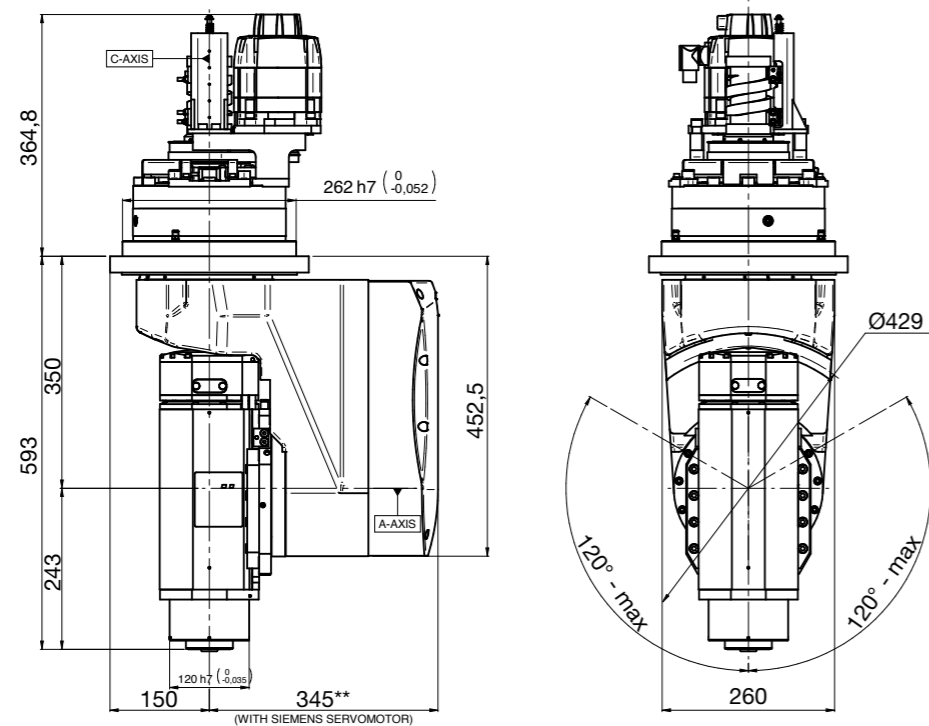

QT-2 13/6 16 63E NC

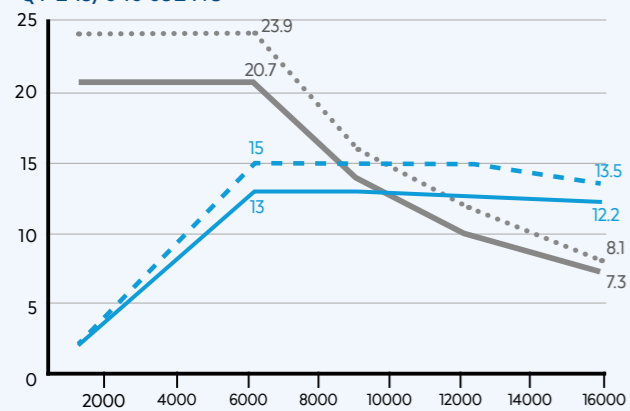

**kW** 13 kW **rpm** 16000 Liquid cooling HSK 63E

QT-2 25/7 16 63E NC ES

SYNCHRONOUS

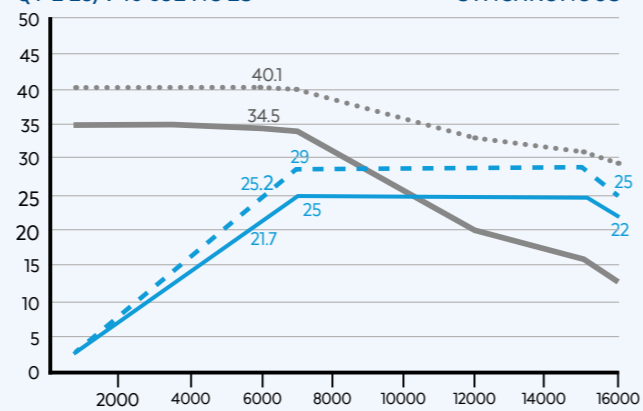

**kW** 25 kW **rpm** 16000 Liquid cooling HSK 63E

Encoder 1Vpp o TTL

— POTENZA / POWER SI (KW)

— COPPIA / TORQUE SI (NM)

- - - POTENZA / POWER S6 50% (KW)

..... COPPIA / TORQUE S6 50% (NM)

\*\* Per altri motori +X mm / For other motors +X mm





# SERIE TILT TILT W



- LIGHT ALLOYS
- ADVANCED MATERIALS
- PLASTIC
- WOOD

AVAILABLE WITH



## LAYOUT

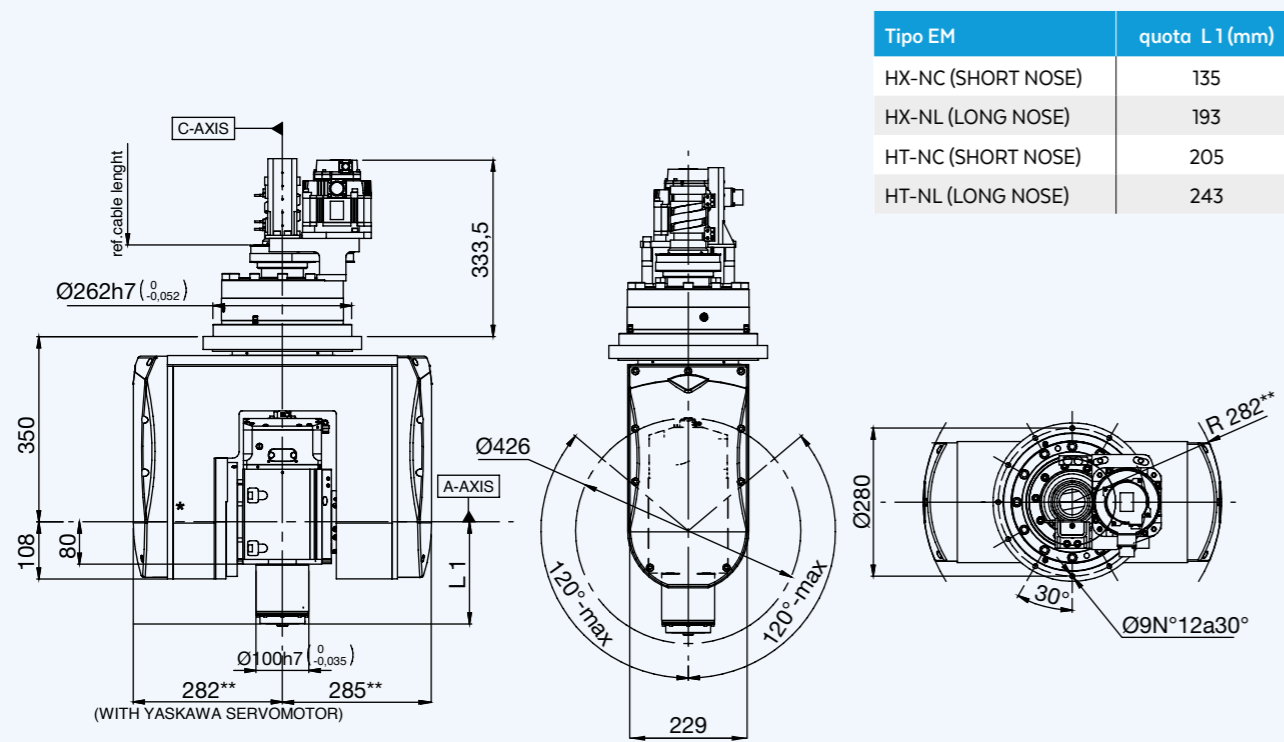

## OPTIONALS DELL'ELETTROMANDRINO / ELECTROSPINDLE OPTIONS

- Naso corto / Short nose
- HSK 63F
- HSK 63A
- Oil mist/ MQL
- Monitoraggio temperatura cuscinetti / Temperature monitoring of bearings
- Misuratore di velocità / Speed monitoring
- Sensori di vibrazione / Vibration sensor
- Air tool

## SPECIFICHE TECNICHE / TECHNICAL SPECIFICATIONS

\*Sono disponibili altre marche di motorizzazioni a richiesta  
\*Other engine brands are available on demand

	ASSE A / A AXIS	ASSE C / C AXIS
Servomotore / Servomotor	Yaskawa*	Yaskawa*
Potenza servomotore / Servomotor power	0,75 kW	0,85 kW
Encoder servomotore / Servomotor encoder	Assoluto Absolute 20 Bit	Assoluto Absolute 20 Bit
Riduttore / Gearbox	Sumitomo	Sumitomo
Coppia max continua / Max. continuous torque	425 Nm	635 Nm
Coppia di picco / Peak torque	1030 Nm	1962 Nm
Max rotazione asse / Max axis rotation	±120°	±320°
Velocità posizionamento max / Max. positioning speed	10.000°/'	12.500°/'
Freni meccanici / Mechanical blocking of axes	Si Yes	Si Yes
Encoder assi / Axis encoder optional	Si Yes (OPT)	Si Yes (OPT)
Precisione / Accuracy	±30 arcsec (±15 arcsec)*	±30 arcsec (±15 arcsec)*
Ripetibilità / Repeatability	±10 arcsec (±5 arcsec)*	±10 arcsec (±5 arcsec)*
Utenze / External air connections		n2
Peso / Weight		210 kg

\*Con encoder assi / With encoder axis

## ELETTROMANDRINI DISPONIBILI / AVAILABLE ELECTROSPINDLES

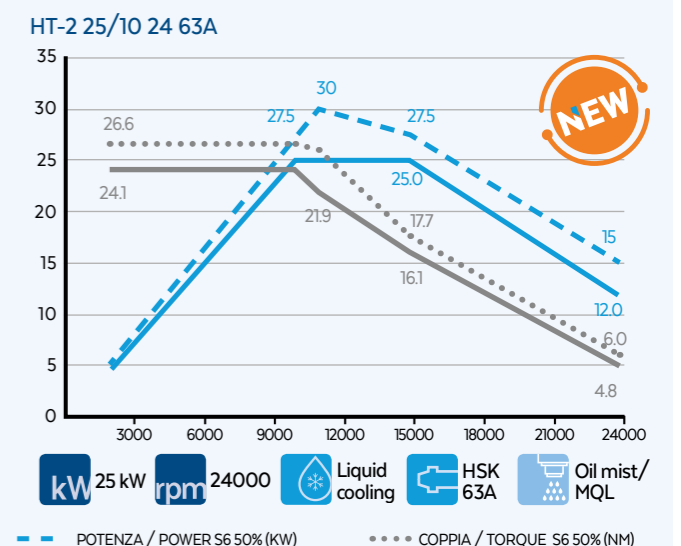
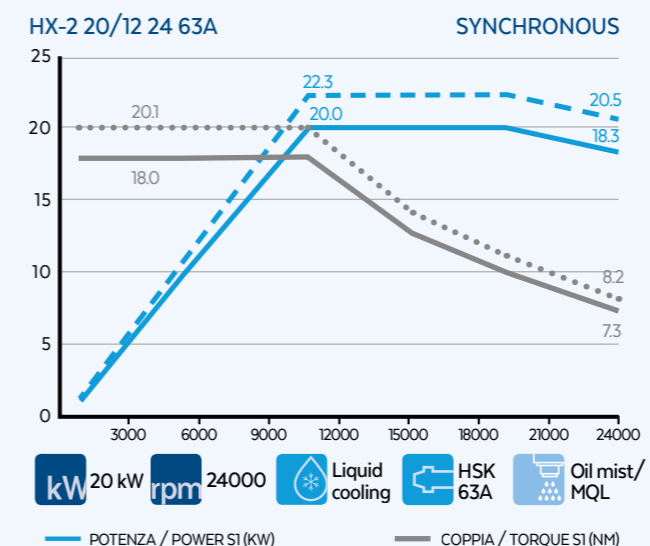
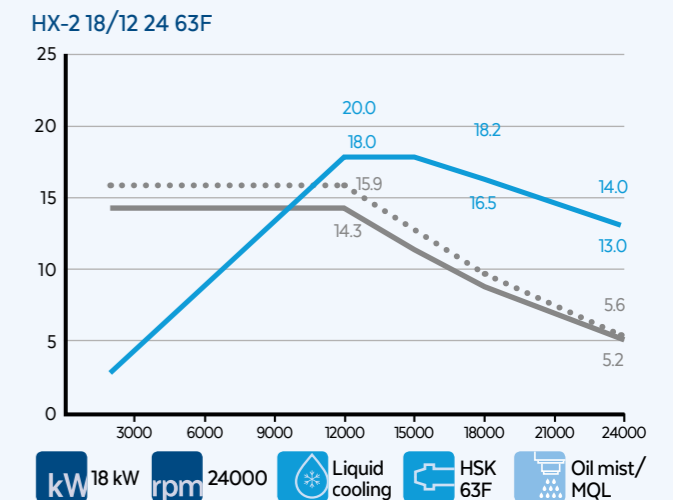
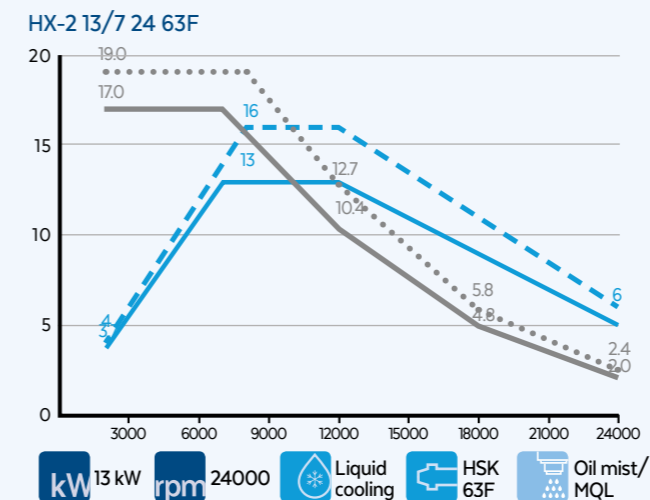

# SERIE TILT TILT TLP



- LIGHT ALLOYS
- ADVANCED MATERIALS
- PLASTIC
- WOOD

AVAILABLE WITH



## LAYOUT

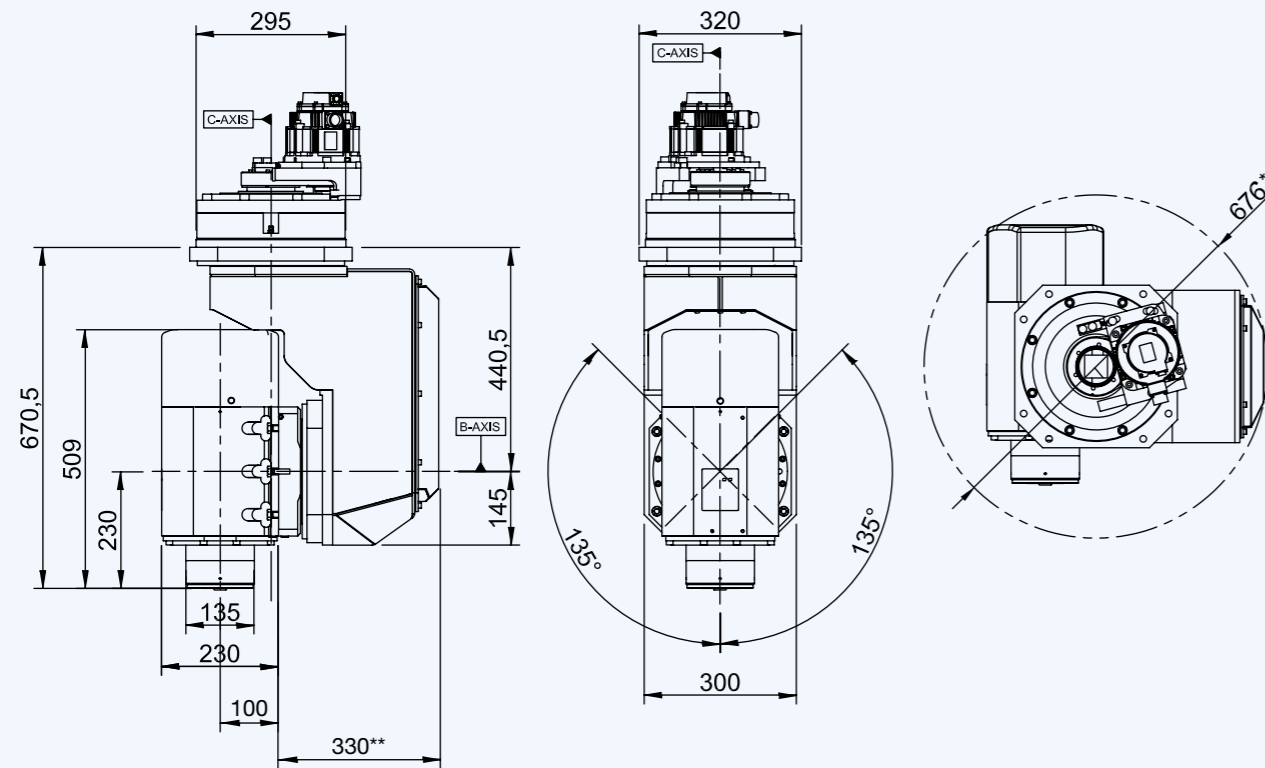

## OPTIONALS DELL'ELETTROMANDRINO / ELECTROSPINDLE OPTIONS

- Oil mist/MQL
- Monitoraggio temperatura cuscinetti / Temperature monitoring of bearings
- Misuratore di velocità / Speed monitoring
- Sensori di vibrazione / Vibration sensor
- Air tool
- Encoder (standard with hsk 63A)

## SPECIFICHE TECNICHE / TECHNICAL SPECIFICATIONS

\*Sono disponibili altre marche di motorizzazioni a richiesta  
\*Other engine brands are available on demand

	ASSE A / A AXIS	ASSE C / C AXIS
Servomotore / Servomotor	Yaskawa*	Yaskawa*
Potenza servomotore / Servomotor power	0,75 kW	0,85 kW
Encoder servomotore / Servomotor encoder	Assoluto Absolute 20 Bit	Assoluto Absolute 20 Bit
Riduttore / Gearbox	Sumitomo	Sumitomo
Coppia max continua / Max. continuous torque	800 Nm	636 Nm
Coppia di picco / Peak torque	1962 Nm	3188 Nm
Max rotazione asse / Max axis rotation	±135°	±320°
Velocità posizionamento max / Max. positioning speed	10.000°/'	11.000°/'
Freni meccanici / Mechanical blocking of axes	Si Yes	Si Yes
Encoder assi / Axis encoder optional	Si Yes (OPT)	Si Yes (OPT)
Precisione / Accuracy	±30 arcsec (±15 arcsec)*	±30 arcsec (±15 arcsec)*
Ripetibilità / Repeatability	±10 arcsec (±5 arcsec)*	±10 arcsec (±5 arcsec)*
Precisione di posizionamento assi / Axis positioning accuracy	1 arcmin	1 arcmin
Peso / Weight		250 kg

\*Con encoder assi / With encoder axis

## ELETTROMANDRINI DISPONIBILI / AVAILABLE ELECTROSPINDLES

QM-2 30/6 13 80F NC

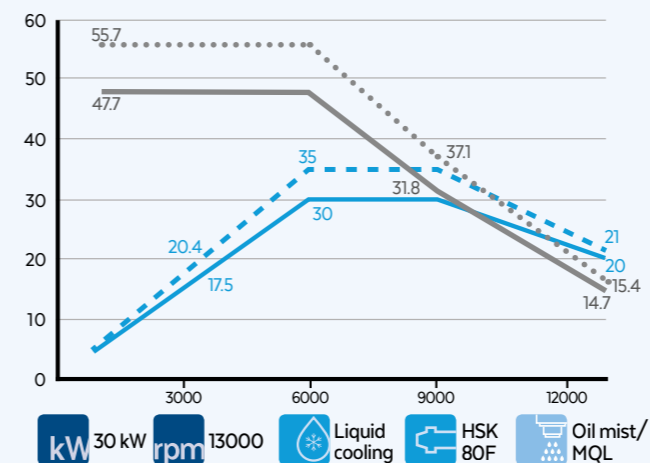

QM-2 30/6 13 63A NC ES

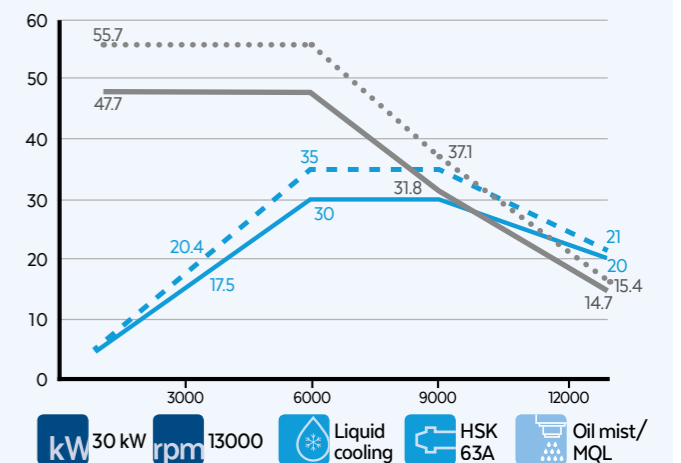

QM-2 30/6 13 85S NC

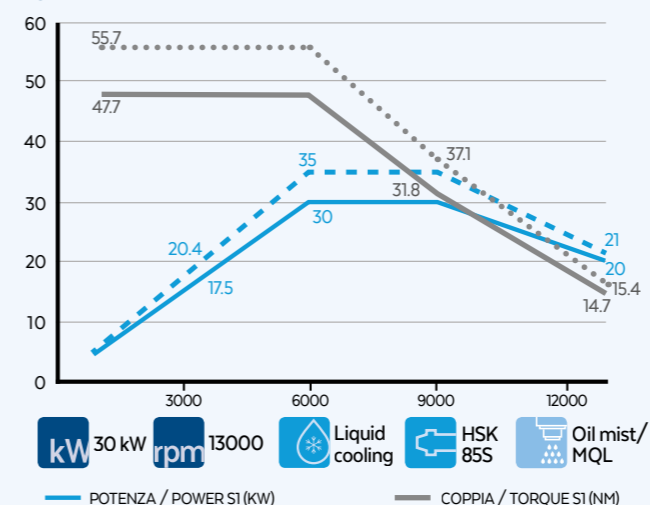





ss 258 Marecchia, 34 47826 Villa Verucchio, Rimini - Italia

tel. +39.0541.674940 - fax +39.0541.674962

[www.hiteco.net](http://www.hiteco.net)