

## AC/DC Geared Motor and Gearbox

**DKM Motor Co., Ltd.**

## Global Network ▶▶

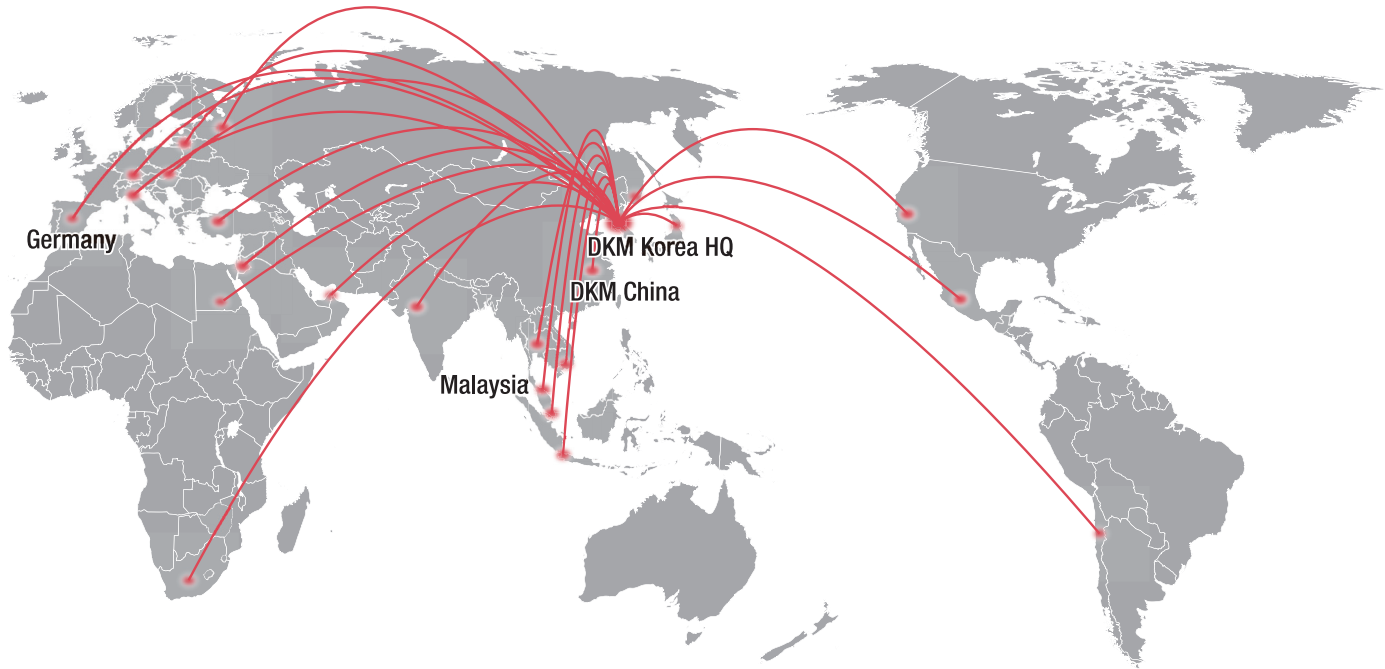

**Global Headquarter**  
Incheon, KOREA



**DKM China**  
Shanghai, CHINA



**DKM Malaysia**  
JB, Malaysia



**German Partner OTT GmbH**  
Deisslingen, Germany

### Headquarters

4F., Incheon Techpia Na-Bldg., Geobukro 17, Seo-gu,  
Incheon, Korea  
Tel: +82 32 574 7788 Fax: +82 32 578 7787  
[www.dkmmotor.com](http://www.dkmmotor.com) | [info@dkmmotor.com](mailto:info@dkmmotor.com)

### DKM China

No. 555 Lianming Road, Qibao Toun Minhang Shanghai,  
China 201101  
Tel: +86 21 6461 9665 Fax: +86 21 6459 5115  
[www.dkmmotor.com](http://www.dkmmotor.com) | [dh.kim@dkmmotor.com](mailto:dh.kim@dkmmotor.com)

### DKM Malaysia

No. 23A, Jalan Jati 2, Taman Nusa Bestari Jaya, 81300 Skudai,  
Johor Bahru, Johor, Malaysia  
Tel: +607 511 4313 Fax: +607 511 6313  
[www.servo-matic.com.my](http://www.servo-matic.com.my) | [account@servo-matic.com.my](mailto:account@servo-matic.com.my)

### German Partner

Ott GmbH & Co. KG Antriebstechnik Electronic  
Baarstrasse 3, 78652 Deisslingen, Germany  
Tel: +49 7420 9399-0  
Fax: +49 7420 9399-25  
[www.ott-antriebe.de](http://www.ott-antriebe.de) | [Info@ott-antriebe.de](mailto:Info@ott-antriebe.de)

## History

- 1983 The father company, 'Daekyung Machinery Co.' founded
- 1987 Developed 'Small Geared Motor' first time in Korea
- 1990 Starts export to overseas markets including China
- 1993 Acquired 'Q Mark' in Small Geared division from Korean government
- 1994 Acquired 'NT New Technology Mark' from Korean government
- 1995 Starts export to India, Indonesia and Malaysia
- 1999 Acquired CE (in some parts of Induction Motor) Advanced into Europe
- 2000 Changed company name to DKM Co., Ltd., the holding company
- 2002 Acquired ISO 9001:2000
- 2004 Acquired 'CCC' certificate
- 2005 Established 'DKM Shanghai Co., Ltd.' in Shanghai, China
- 2008 Established 'DKM South Asia Pte Ltd.' in Singapore
- 2009 Established 'DKM Europe' in Germany
- 2010 Relocation and extension of global headquarters
- 2011 Unveiled a new corporate identity

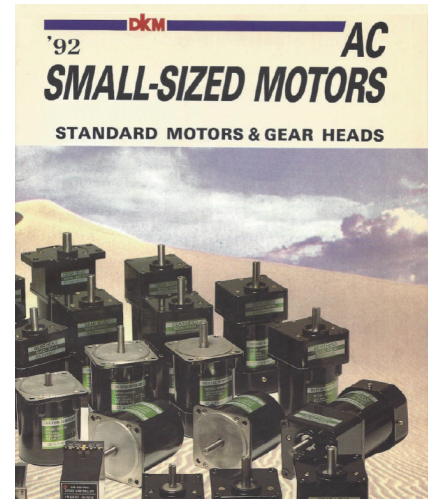



## Production ▶▶



## Metal Processing

DKM Motor has a long worth of know-how since its foundation in manufacturing metal processing components. We are making all metal cutting processes: turning with single or multi-spindle machines, gearing by hobbing machine, heat treatments and hardening processes.



## Assembly and Test

By using the precision assembly machines DKM Motor is making assembly of the selected components by the internal quality standard. We are making total 3 times test ; the test of the components before assembly, the test after assembly and the final shipping test after assembly of motor and gearbox.

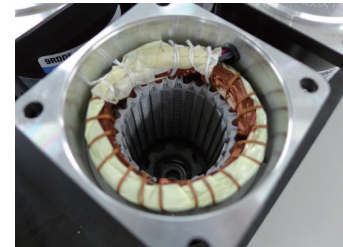
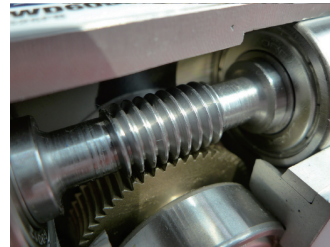





## Design

The design department of DKM Motor is connected to the development of all products and our R&D team is on stand-by for comprehensive and fast adaptations to match your specific requirements and specifications.

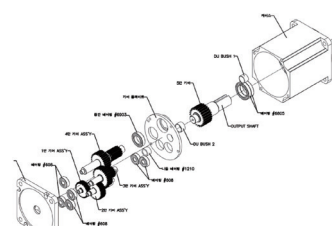
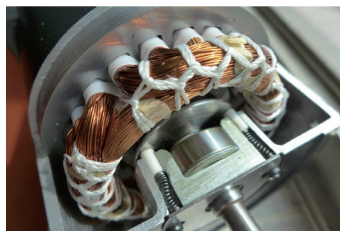

## Laboratories

DKM carries out stress, wear, tear and life tests with the test machines.

Through this test process in our own test laboratory we can get the permissible torque and other limit values of each products will meet the required demands.

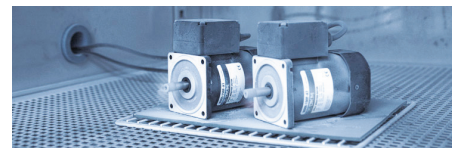
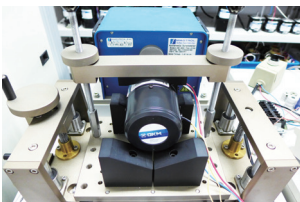

## Quality Assurance

We always carries out the reliability test for sampling products from all manufactured products. By this test we can handle any faulty in advance.

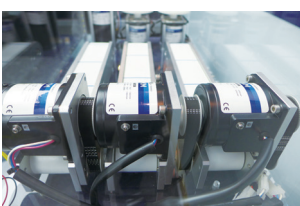



## Marketing ▶▶



### Global Exhibitions

DKM Motor is making its efforts to inform the customers of the products by effective method through various marketing channels. Since the establishment in 1983, we have participated continuously in domestic/overseas industry/machinery exhibition and introduced our products through dealer conference/technical seminar and received the requirements from agency and users to reflect in the production of better product.

Besides, through regular distribution of press release and the sending of news letter, we are delivering the news and the information of new product of DKM quickly.

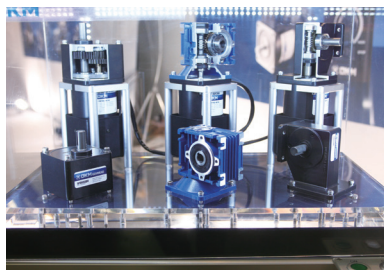

Neue Antriebsbaureihen zum Beispiel für die Förder- und Galvanotechnik

[www.ott-antriebe.de](http://www.ott-antriebe.de)

- DC Motoren
- AC Motoren
- Getriebemotoren
- Steuerungen
- Netzteile
- Kupplungen

Wir realisieren Antriebslösungen in nahezu allen Bereichen. Hierzu greifen wir auf unser Lager mit über 80.000 Motoren sowie über 1.000 Steuerungen zurück.

**Ott GmbH & Co. KG**  
 Basistrasse 3  
 D-78652 Delllingen  
 Tel. 07420-9399-0  
 Fax 07420-9399-25

[www.ott-antriebe.de](http://www.ott-antriebe.de)



## Partners Conferences

DKM Motor is opening Partners Conferences regularly all over the world. This meeting enables DKM Motor and the partners to communicate and exchange the news each other.













## Technical Seminar





# DKM Products Overview ▶▶

AC MOTORS		
<p><b>Induction Motor</b></p>	<ul style="list-style-type: none"> <li>- Constant speed with continuous operation</li> <li>- Stop in 2 sec. when switched off (Overrun: 30-40 times)</li> <li>- Possible for reverse rotation</li> </ul>	<div style="display: flex; justify-content: space-around;"> <div style="text-align: center;">  <p>Lead Wire Type</p> </div> <div style="text-align: center;">  <p>Terminal Box Type</p> </div> </div>
<p><b>2 Pole Motor</b></p>	<ul style="list-style-type: none"> <li>- High speed rotation</li> <li>- 3,600r/min (60Hz)</li> <li>- 3,000r/min (50Hz)</li> <li>- Used without Gearbox</li> <li>- Possible for reverse rotation</li> </ul>	<div style="display: flex; justify-content: space-around;"> <div style="text-align: center;">  <p>Lead Wire Type</p> </div> <div style="text-align: center;">  <p>Terminal Box Type</p> </div> </div>
<p><b>Reversible Motor</b></p>	<ul style="list-style-type: none"> <li>- Suitable for frequent reverse operation</li> <li>- Stop in 0.5 sec. when switched off (Overrun: 5-6 times)</li> <li>- Possible for reverse rotation</li> </ul>	<div style="display: flex; justify-content: space-around;"> <div style="text-align: center;">  <p>Lead Wire Type</p> </div> <div style="text-align: center;">  <p>Terminal Box Type</p> </div> </div>
<p><b>Brake Motor</b></p>	<ul style="list-style-type: none"> <li>- Suitable for operation where load should be maintained</li> <li>- Stop in 0.2 sec. when switched off (Overrun: 2-3 times)</li> <li>- Possible for reverse rotation</li> </ul>	<div style="text-align: center;">  </div>
<p><b>Clutch &amp; Brake Motor</b></p>	<ul style="list-style-type: none"> <li>- Suitable for high frequent start and stop operation</li> <li>- Stop in 0.1 sec. when switched off (Overrun: 1 time)</li> <li>- Used always with Gearbox</li> <li>- Possible for reverse rotation</li> </ul>	<div style="text-align: center;">  </div>
<p><b>Torque Motor</b></p>	<ul style="list-style-type: none"> <li>- Suitable for controlling tension and pushing in winding operations</li> <li>- Easy control of motor torque by using torque controller</li> <li>- Possible for reverse rotation</li> </ul>	<div style="text-align: center;">  </div>
<p><b>Speed Control System</b></p> <ul style="list-style-type: none"> <li>- S.C. Induction Motor</li> <li>- S.C. Reversible Motor</li> <li>- S.C. Brake Motor</li> <li>- S.C. Clutch &amp; Brake Motor</li> </ul>	<ul style="list-style-type: none"> <li>- Speed control motor allows you to set and adjust the speed of the motor easily by using speed controller.</li> <li>- Speed Controller: FX1000A DSKM</li> </ul>	<div style="display: flex; justify-content: space-between;"> <div data-bbox="953 1895 1179 2216" style="width: 48%;"> <p style="text-align: center;"><b>Speed Controller FX1000A</b></p> <div style="text-align: center;">  </div> <ul style="list-style-type: none"> <li>- Front panel potentiometer</li> <li>- Unit type (Connecting motor with easy-to-use connector)</li> </ul> </div> <div data-bbox="1182 1895 1587 2216" style="width: 48%;"> <p style="text-align: center;"><b>DSKM</b></p> <div style="text-align: center;">  </div> <ul style="list-style-type: none"> <li>- Front panel potentiometer, Socket type (Connecting motor with socket), External volume attachable</li> </ul> </div> </div>

## DC MOTORS

### DC Motor

- Big starting torque and high efficiency
- Easy to control the speed and change the normal/reverse rotation
- Superiority in the responsiveness of operation and stop
- Possible to attach parallel and worm Gearbox



### Speed Controller DSD-90

- Applicable to DC 90V motor
- Front panel potentiometer, Unit type



## Gearbox

### Parallel Gearbox



- General Box Type, Powerful Box / Flange Type, High Powerful Box / Flange Type
- Frame Size: 60/70/80/90/104mm
- Gear Ratio: 2 : 1~360 : 1

### Worm Gearbox



- Maximum use of install space
- Worm Solid Type Gearbox  
Frame Size: 80/90mm  
Gear Ratio: 10 : 1~60 : 1
- Worm Hollow Type Gearbox  
Frame Size: 90mm/104mm  
Gear Ratio: 7.5 : 1~80 : 1

### Inter-decimal Gearbox



- In case of requiring high gear ratio that cannot be generated by single Gearbox
- Frame Size: 80/90mm
- Gear Ratio: 10 : 1

Trust

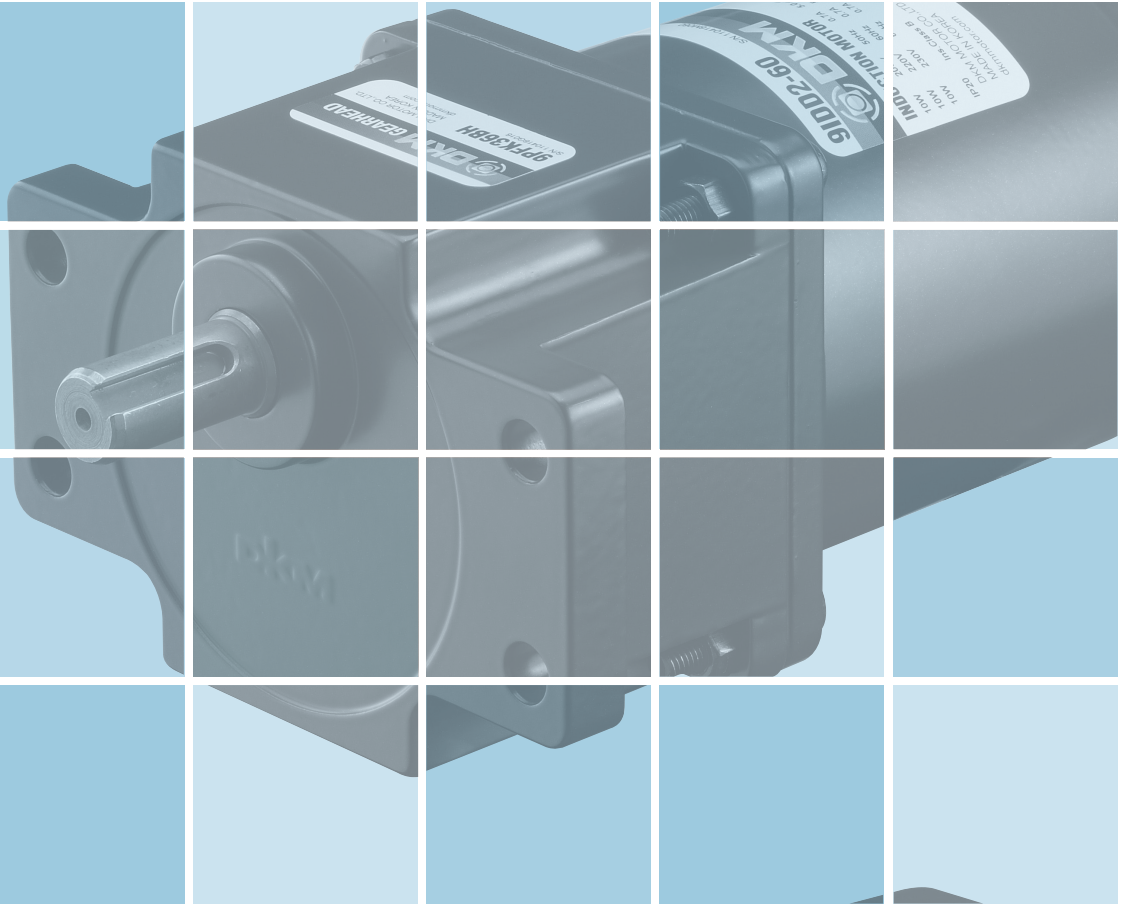

Value

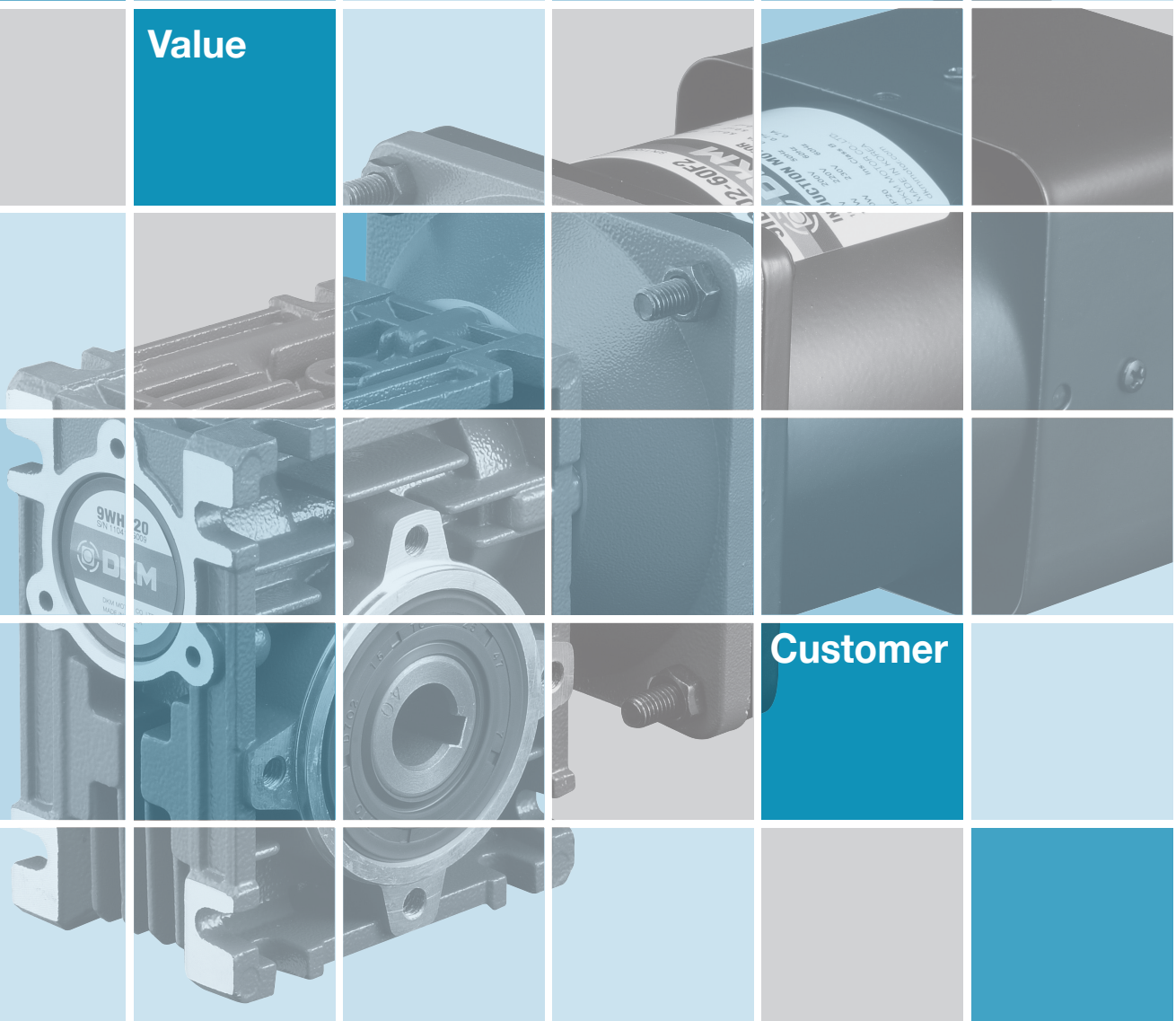

Customer



## Contents ▶▶

## **A** Information

- A-01** Product Coding System
- A-04** Products Lineup
- A-08** General Information
- A-12** Terminology
- A-15** Caution for Using

## **B** AC Motors

- B-01** Technical Data of AC Motor
- B-06** Induction Motor
- B-56** 2 Pole Motor
- B-74** Reversible Motor
- B-106** Brake Motor
- B-148** Clutch & Brake Motor
- B-162** Torque Motor
- B-176** Speed Control System
  - B-179** Speed Controller FX1000A
  - B-181** Speed Controller DSKM
  - B-186** Speed Control Induction Motor
  - B-222** Speed Control Reversible Motor
  - B-250** Speed Control Brake Motor
  - B-276** Speed Control Clutch & Brake Motor

## **C** DC Motors

- C-01** Technical Data of DC Motor
- C-04** DC Motor
- C-17** Speed Controller DSD-90

## **D** Gearboxes

- D-01** Technical Data of Gearbox
- D-07** Parallel Gearbox
- D-13** Worm Gearbox
- D-16** Inter-decimal Gearbox

## **E** Options

- E-01** Mounting Plate
- E-02** Extension Cable
- E-03** Output Flange / Output Shaft

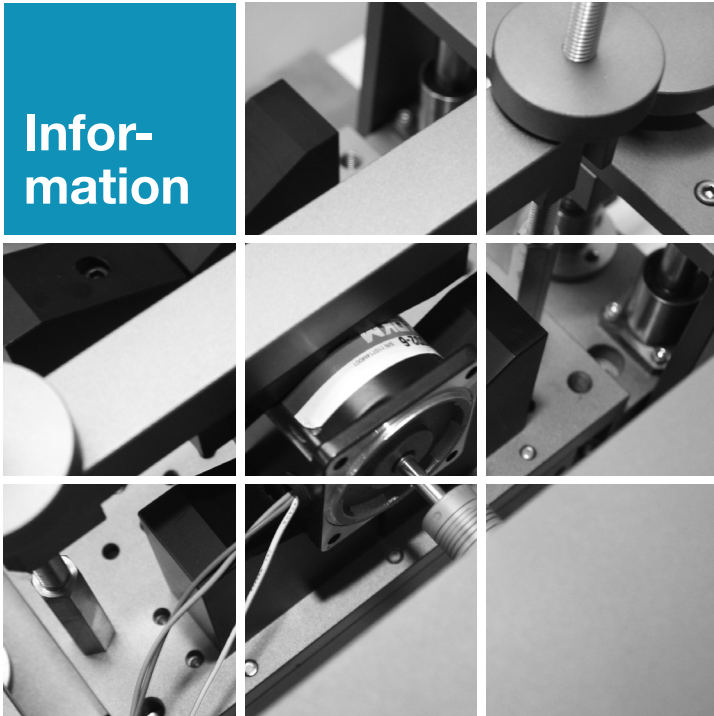

## Contents ▶▶

## **A** Information

- A-01** Product Coding System
- A-04** Products Lineup
- A-08** General Information
- A-12** Terminology
- A-15** Caution for Using

## **B** AC Motors

- B-01** Technical Data of AC Motor
- B-06** Induction Motor
- B-56** 2 Pole Motor
- B-74** Reversible Motor
- B-106** Brake Motor
- B-148** Clutch & Brake Motor
- B-162** Torque Motor
- B-176** Speed Control System
  - B-179** Speed Controller FX1000A
  - B-181** Speed Controller DSKM
  - B-186** Speed Control Induction Motor
  - B-222** Speed Control Reversible Motor
  - B-250** Speed Control Brake Motor
  - B-276** Speed Control Clutch & Brake Motor

## **C** DC Motors

- C-01** Technical Data of DC Motor
- C-04** DC Motor
- C-17** Speed Controller DSD-90

## **D** Gearboxes

- D-01** Technical Data of Gearbox
- D-07** Parallel Gearbox
- D-13** Worm Gearbox
- D-16** Inter-decimal Gearbox

## **E** Options

- E-01** Mounting Plate
- E-02** Extension Cable
- E-03** Output Flange / Output Shaft



# A Information

## Product Coding System

### AC Motors

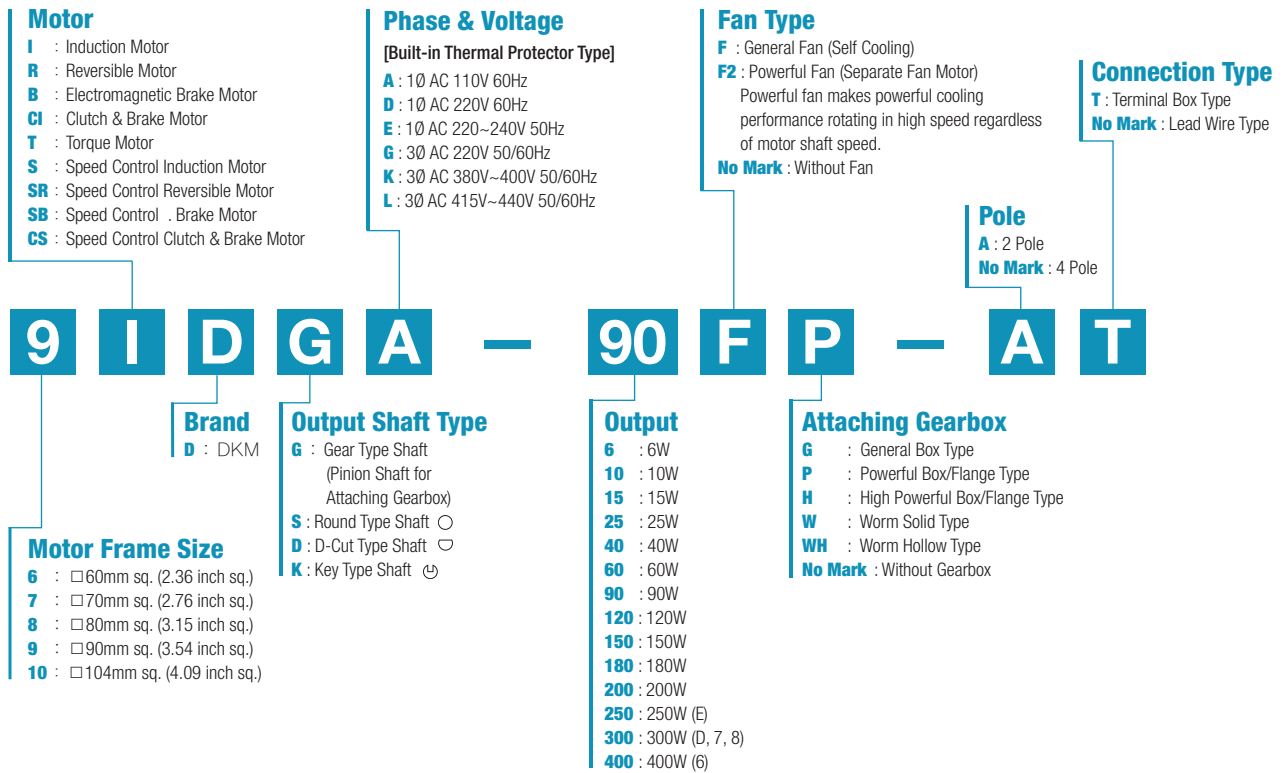

### DC Motors

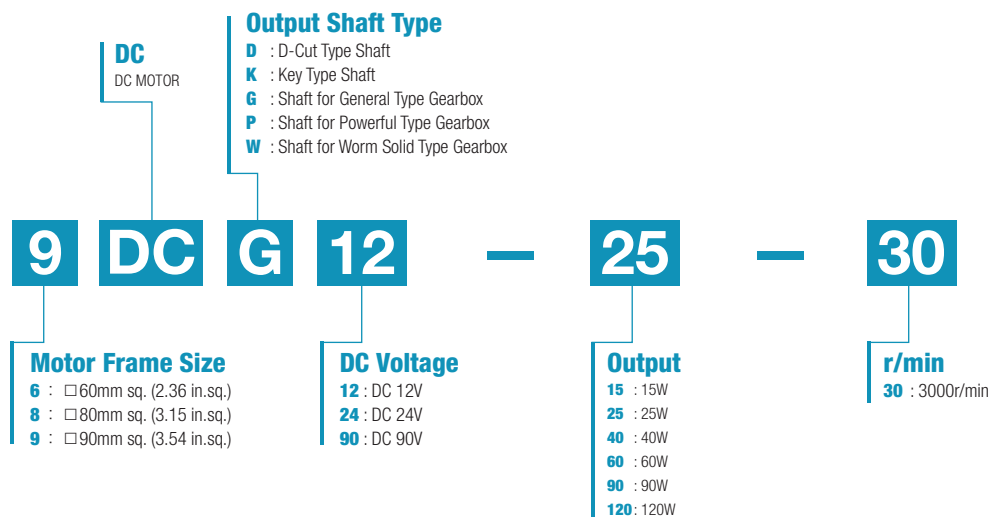

## Parallel Gearbox

### Gearbox Frame Size

- 6 : □60mm sq. (2.36 in.sq.)
- 7 : □70mm sq. (2.76 in.sq.)
- 8 : □80mm sq. (3.15 in.sq.)
- 9 : □90mm sq. (3.54 in.sq.)

### Frame Type

- B : Box Type □
  - F : Flange Type ◻
- (Only available for powerful and high powerful type Gearbox)

### Bearing Type

- B : Ball Bearing
- BM : Ball Bearing + Metal Bearing
- M : Metal Bearing

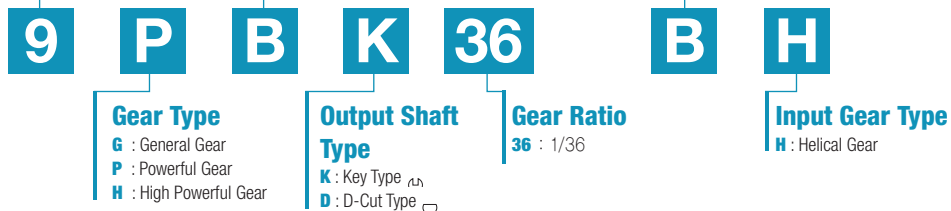

## Worm Solid Gearbox

### Gearbox Type

- W : Worm Solid Type
- WH : Worm Hollow Type

### Gear Ratio

30 : 1/30

### Direction of Output Shaft

- L : Left
  - R : Right
  - RL : Bi-directional
- ※ No mark in Worm Hollow Type Gearbox



### Gearbox Frame Size

- 8 : □80mm sq. (3.15 in.sq.)
- 9 : □90mm sq. (3.54 in.sq.)

### Brand

D : DKM

### Bearing Type

- B : Ball Bearing
- ※ No mark in Worm Hollow Type Gearbox

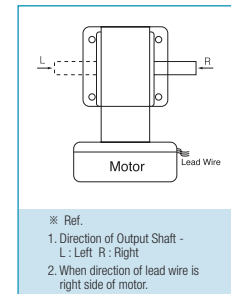

## Worm Hollow Gearbox

### Gearbox Type

WH : Worm Hollow Gearbox

### Gear Ratio

30 : 1/30



### Gearbox Frame Size

- 9 : □90mm sq. (4.09 in.sq.)
- 10 : □104mm sq. (4.09 in.sq.)

### Brand

D : DKM

Center Distance between

- Worm Wheel and Shaft
- 030 : 30mm
- 040 : 40mm

## Inter-decimal Gearbox

### X10 Inter-decimal Gearbox



### Gearbox Frame Size

- 8 : □80mm sq. (3.15 in.sq.)
- 9 : □90mm sq. (3.54 in.sq.)

### Brand

D : DKM

### Gear Ratio

10 : 1/10

### Attaching Gearbox

- G : General Type (Helical)
- P : Powerful Type
- H : High Powerful Type
- Z : Worm Hollow Type
- W : Worm Solid type

- G : "G" Type Shaft Motor (40W)
- P : "P" Type Shaft Motor (60~120W)

In case of requiring high gear reduction ratio that cannot be generated by single Gearbox, please use Inter-decimal Gearbox with general Gearbox. And please be advised that in this case only revolution speed of output shaft will reduce by 10:1 without increasing of maximum permissible torque.

# A Information

## Product Coding System

### Assembly of Motor and Gearbox

#### Motor + Gearbox

- As shown in the following scheme, motor and Gearbox which have same frame size and gear type could be assembled.

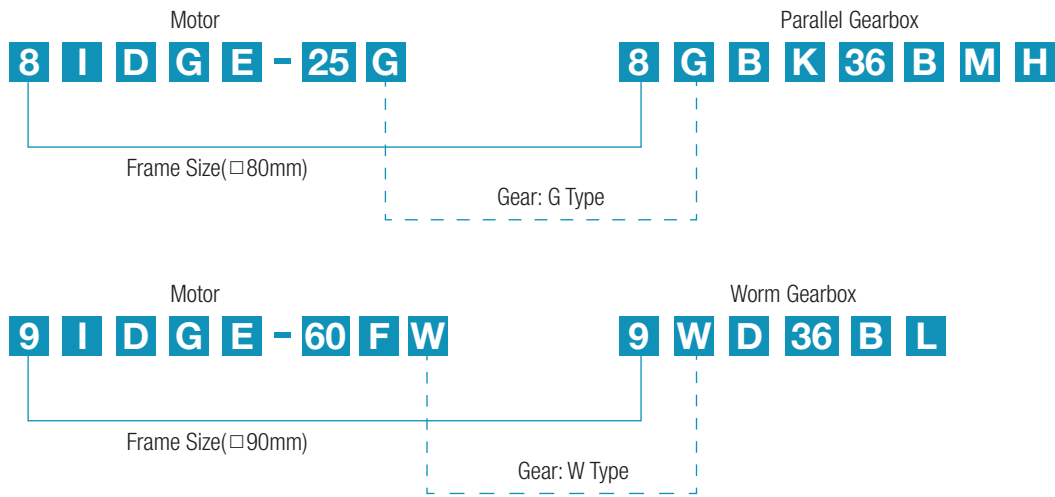

#### Motor + Inter-decimal Gearbox + Gearbox

- When using an inter-decimal Gearbox together, give attention to the gear types of motor, Gearbox and inter-decimal Gearbox.

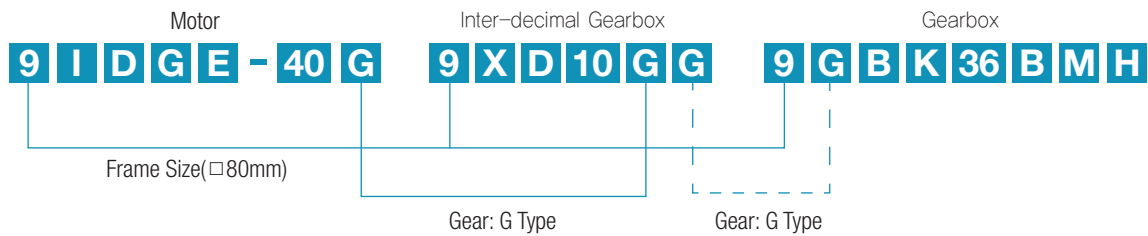

- When attaching inter-decimal Gearbox, the output shaft type of the motor is always G type. For example, when using P/H/W/WH type Gearbox, only the gear type of inter-decimal Gearbox is identical with attached Gearbox and the output shaft type of the motor is G type. (Refer to the scheme below.)

## Products Lineup

### AC Motors

Frame Size	Voltage Output	Induction Motor						Page
		A 1∅ 110V 60Hz	D 1∅ 220V 60Hz	E 1∅ 220~240V 50Hz	G 3∅ 220V 50/60Hz	K 3∅ 380V~400V 50/60Hz	L 3∅ 415V~440V 50/60Hz	
60mm	6W	6D*A-6□(-T)	6D*D-6□(-T)	6D*E-6□(-T)	-	-	-	B-09
70mm	6W	7D*A-6□(-T)	7D*D-6□(-T)	7D*E-6□(-T)	-	-	-	B-11
	10W	7D*A-10□(-T)	7D*D-10□(-T)	7D*E-10□(-T)	-	-	-	B-13
	15W	7D*A-15□(-T)	7D*D-15□(-T)	7D*E-15□(-T)	-	-	-	B-15
80mm	15W	8D*A-15□(-T)	8D*D-15□(-T)	8D*E-15□(-T)	8D*G-15□(-T)	8D*K-15□(-T)	8D*L-15□(-T)	B-17
	25W	8D*A-25□(-T)	8D*D-25□(-T)	8D*E-25□(-T)	8D*G-25□(-T)	8D*K-25□(-T)	8D*L-25□(-T)	B-20
90mm	40W	9D*A-40□(-T)	9D*D-40□(-T)	9D*E-40□(-T)	9D*G-40□(-T)	9D*K-40□(-T)	9D*L-40□(-T)	B-23
	60W	9D*A-60F□(-T)	9D*D-60F□(-T)	9D*E-60F□(-T)	9D*G-60F□(-T)	9D*K-60F□(-T)	9D*L-60F□(-T)	B-26
	90W	9D*A-90F□(-T)	9D*D-90F□(-T)	9D*E-90F□(-T)	9D*G-90F□(-T)	9D*K-90F□(-T)	9D*L-90F□(-T)	B-30
	120W	9D*A-120F□(-T)	9D*D-120F□(-T)	9D*E-120F□(-T)	9D*G-120F□(-T)	9D*K-120F□(-T)	9D*L-120F□(-T)	B-34
	150W	-	-	-	9D*G-150F□(-T)	9D*K-150F□(-T)	9D*L-150F□(-T)	B-38
	180W	-	9D*D-180F□(-T)	9D*E-180F□(-T)	-	-	-	B-41
	200W	-	-	-	9D*G-200F□(-T)	9D*K-200F□(-T)	9D*L-200F□(-T)	B-44
104mm	250W	-	-	10IDGE-250F□(-T)	-	-	-	B-47
	300W	-	10IDGD-300F□(-T)	-	-	10IDG7-300F□(-T)	10IDG8-300F□(-T)	B-50
	400W	-	-	-	10IDG6-400F□(-T)	-	-	B-53

Frame Size	Voltage Output	2 Pole Motor						Page
		A 1∅ 110V 60Hz	D 1∅ 220V 60Hz	E 1∅ 220~240V 50Hz	G 3∅ 220V 50/60Hz	K 3∅ 380V~400V 50/60Hz	L 3∅ 415V~440V 50/60Hz	
80mm	15W	8D*A-15-A(-T)	8D*D-15-A(-T)	8D*E-15-A(-T)	8D*G-15-A(-T)	-	-	B-57
	25W	8D*A-25-A(-T)	8D*D-25-A(-T)	8D*E-25-A(-T)	8D*G-25-A(-T)	-	-	B-59
90mm	40W	9D*A-40-A(-T)	9D*D-40-A(-T)	9D*E-40-A(-T)	9D*G-40-A(-T)	9D*K-40-A(-T)	9D*L-40-A(-T)	B-61
	60W	9D*A-60F-A(-T)	9D*D-60F-A(-T)	9D*E-60F-A(-T)	9D*G-60F-A(-T)	9D*K-60F-A(-T)	9D*L-60F-A(-T)	B-63
	90W	9D*A-90F-A(-T)	9D*D-90F-A(-T)	9D*E-90F-A(-T)	9D*G-90F-A(-T)	9D*K-90F-A(-T)	9D*L-90F-A(-T)	B-65
	120W	9D*A-120F-A(-T)	9D*D-120F-A(-T)	9D*E-120F-A(-T)	9D*G-120F-A(-T)	9D*K-120F-A(-T)	9D*L-120F-A(-T)	B-67
	150W	-	-	-	9D*G-150F-A(-T)	9D*K-150F-A(-T)	9D*L-150F-A(-T)	B-69
	200W	-	-	-	9D*G-200F-A(-T)	9D*K-200F-A(-T)	9D*L-200F-A(-T)	B-71

Frame Size	Voltage Output	Reversible Motor						Page
		A 1∅ 110V 60Hz	D 1∅ 220V 60Hz	E 1∅ 220~240V 50Hz	G 3∅ 220V 50/60Hz	K 3∅ 380V~400V 50/60Hz	L 3∅ 415V~440V 50/60Hz	
60mm	6W	6RD*A-6□(-T)	6RD*D-6□(-T)	6RD*E-6□(-T)	-	-	-	B-75
70mm	6W	7RD*A-6□(-T)	7RD*D-6□(-T)	7RD*E-6□(-T)	-	-	-	B-77
	10W	7RD*A-10□(-T)	7RD*D-10□(-T)	7RD*E-10□(-T)	-	-	-	B-79
	15W	7RD*A-15□(-T)	7RD*D-15□(-T)	7RD*E-15□(-T)	-	-	-	B-83
80mm	15W	8RD*A-15□(-T)	8RD*D-15□(-T)	8RD*E-15□(-T)	-	-	-	B-85
	25W	8RD*A-25□(-T)	8RD*D-25□(-T)	8RD*E-25□(-T)	-	-	-	B-88
90mm	40W	9RD*A-40□(-T)	9RD*D-40□(-T)	9RD*E-40□(-T)	-	-	-	B-91
	60W	9RD*A-60F□(-T)	9RD*D-60F□(-T)	9RD*E-60F□(-T)	-	-	-	B-94
	90W	9RD*A-90F□(-T)	9RD*D-90F□(-T)	9RD*E-90F□(-T)	-	-	-	B-98
	120W	9RD*A-120F□(-T)	9RD*D-120F□(-T)	9RD*E-120F□(-T)	-	-	-	B-102

1. Enter the output shaft type of motor (G: Gear Type/S: Round Type/D: D-Cut Type/K: Key Type) in the place \* within the motor model name.
2. Enter the model type of attaching Gearbox (G Type/P Type/H Type/W Type/WH Type) in the box (□) within the motor model name.
3. When using terminal box type motor, '-T' is added to the end of the motor model name.
4. All models contain a built-in thermal protector.



# A Information

## Products Lineup

### AC Motors

Frame Size	Voltage		Brake Motor					Page	
	Output		A 1∅ 110V 60Hz	D 1∅ 220V 60Hz	E 1∅ 220~240V 50Hz	G 3∅ 220V 50/60Hz	K 3∅ 380V~400V 50/60Hz		L 3∅ 415V~440V 50/60Hz
70mm	6W		7BD*A-6□(-T)	7BD*D-6□(-T)	7BD*E-6□(-T)	-	-	-	B-107
	10W		7BD*A-10□(-T)	7BD*D-10□(-T)	7BD*E-10□(-T)	-	-	-	B-109
	15W		7BD*A-15□(-T)	7BD*D-15□(-T)	7BD*E-15□(-T)	-	-	-	B-111
80mm	15W		8BD*A-15□(-T)	8BD*D-15□(-T)	8BD*E-15□(-T)	8BD*G-15□(-T)	8BD*K-15□(-T)	8BD*L-15□(-T)	B-113
	25W		8BD*A-25□(-T)	8BD*D-25□(-T)	8BD*E-25□(-T)	8BD*G-25□(-T)	8BD*K-25□(-T)	8BD*L-25□(-T)	B-115
90mm	40W		9BD*A-40□(-T)	9BD*D-40□(-T)	9BD*E-40□(-T)	9BD*G-40□(-T)	9BD*K-40□(-T)	9BD*L-40□(-T)	B-116
	60W		9BD*A-60F□(-T)	9BD*D-60F□(-T)	9BD*E-60F□(-T)	9BD*G-60F□(-T)	9BD*K-60F□(-T)	9BD*L-60F□(-T)	B-121
	90W		9BD*A-90F□(-T)	9BD*D-90F□(-T)	9BD*E-90F□(-T)	9BD*G-90F□(-T)	9BD*K-90F□(-T)	9BD*L-90F□(-T)	B-124
	120W		9BD*A-120F□(-T)	9BD*D-120F□(-T)	9BD*E-120F□(-T)	9BD*G-120F□(-T)	9BD*K-120F□(-T)	9BD*L-120F□(-T)	B-128
	150W		-	-	-	9BD*G-150F□(-T)	9BD*K-150F□(-T)	9BD*L-150F□(-T)	B-132
	180W		-	9BD*D-180F□(-T)	9BD*E-180F□(-T)	-	-	-	B-136
	200W		-	-	-	9BD*G-200F□(-T)	9BD*K-200F□(-T)	9BD*L-200F□(-T)	B-142

Frame Size	Voltage		Clutch & Brake Motor					Page	
	Output		A 1∅ 110V 60Hz	D 1∅ 220V 60Hz	E 1∅ 220~240V 50Hz	G 3∅ 220V 50/60Hz	K 3∅ 380V~400V 50/60Hz		L 3∅ 415V~440V 50/60Hz
80mm	15W		8CID*A-15□(-T)	8CID*D-15□(-T)	8CID*E-15□(-T)	8CID*G-15□(-T)	8CID*K-15□(-T)	8CID*L-15□(-T)	B-149
	25W		8CID*A-25□(-T)	8CID*D-25□(-T)	8CID*E-25□(-T)	8CID*G-25□(-T)	8CID*K-25□(-T)	8CID*L-25□(-T)	B-151
90mm	40W		9CID*A-40□(-T)	9CID*D-40□(-T)	9CID*E-40□(-T)	9CID*G-40□(-T)	9CID*K-40□(-T)	9CID*L-40□(-T)	B-153
	60W		9CID*A-60F2□(-T)	9CID*D-60F2□(-T)	9CID*E-60F2□(-T)	9CID*G-60F2□(-T)	9CID*K-60F2□(-T)	9CID*L-60F2□(-T)	B-155
	90W		9CID*A-90F2□(-T)	9CID*D-90F2□(-T)	9CID*E-90F2□(-T)	9CID*G-90F2□(-T)	9CID*K-90F2□(-T)	9CID*L-90F2□(-T)	B-157
	120W		9CID*A-120F2□(-T)	9CID*D-120F2□(-T)	9CID*E-120F2□(-T)	9CID*G-120F2□(-T)	9CID*K-120F2□(-T)	9CID*L-120F2□(-T)	B-159

Frame Size	Voltage		Torque Motor					Page	
	Output		A 1∅ 110V 60Hz	D 1∅ 220V 60Hz	E 1∅ 220~240V 50Hz	G 3∅ 220V 50/60Hz	K 3∅ 380V~400V 50/60Hz		L 3∅ 415V~440V 50/60Hz
70mm	6W		7TD*A-6□(-T)	7TD*D-6□(-T)	7TD*E-6□(-T)	-	-	-	B-165
80mm	10W		8TD*A-10□(-T)	8TD*D-10□(-T)	8TD*E-10□(-T)	-	-	-	B-167
90mm	20W		9TD*A-20F2□(-T)	9TD*D-20F2□(-T)	9TD*E-20F2□(-T)	-	-	-	B-169
	30W		9TD*A-30F2□(-T)	9TD*D-30F2□(-T)	9TD*E-30F2□(-T)	-	-	-	B-171
	40W		9TD*A-40F2□(-T)	9TD*D-40F2□(-T)	9TD*E-40F2□(-T)	-	-	-	B-173

1. Enter the output shaft type of motor (G: Gear Type/S: Round Type/D: D-Cut Type/K: Key Type) in the place \* within the motor model name.
2. Enter the model type of attaching Gearbox (G Type/P Type/H Type/W Type/WH Type) in the box (□) within the motor model name.
3. All models contain a built-in thermal protector.

Frame Size	Voltage		Speed Control Induction Motor					Page	
	Output		A 1∅ 110V 60Hz	D 1∅ 220V 60Hz	E 1∅ 220~240V 50Hz	G 3∅ 220V 50/60Hz	K 3∅ 380V~400V 50/60Hz		L 3∅ 415V~440V 50/60Hz
60mm	6W		6SD*A-6□(-T)	6SD*D-6□(-T)	6SD*E-6□(-T)	-	-	-	B-187
	6W		7SD*A-6□(-T)	7SD*D-6□(-T)	7SD*E-6□(-T)	-	-	-	B-189
70mm	10W		7SD*A-10□(-T)	7SD*D-10□(-T)	7SD*E-10□(-T)	-	-	-	B-192
	15W		7SD*A-15□(-T)	7SD*D-15□(-T)	7SD*E-15□(-T)	-	-	-	B-195
80mm	15W		8SD*A-15□(-T)	8SD*D-15□(-T)	8SD*E-15□(-T)	-	-	-	B-198
	25W		8SD*A-25□(-T)	8SD*D-25□(-T)	8SD*E-25□(-T)	-	-	-	B-201
90mm	40W		9SD*A-40□(-T)	9SD*D-40□(-T)	9SD*E-40□(-T)	-	-	-	B-204
	60W		9SD*A-60F2□(-T)	9SD*D-60F2□(-T)	9SD*E-60F2□(-T)	-	-	-	B-207
	90W		9SD*A-90F2□(-T)	9SD*D-90F2□(-T)	9SD*E-90F2□(-T)	-	-	-	B-211
	120W		9SD*A-120F2□(-T)	9SD*D-120F2□(-T)	9SD*E-120F2□(-T)	-	-	-	B-215
	180W		-	9SD*D-180F2□(-T)	9SD*E-180F2□(-T)	-	-	-	B-219

Frame Size	Voltage		Speed Control Reversible Motor					Page	
	Output		A 1∅ 110V 60Hz	D 1∅ 220V 60Hz	E 1∅ 220~240V 50Hz	G 3∅ 220V 50/60Hz	K 3∅ 380V~400V 50/60Hz		L 3∅ 415V~440V 50/60Hz
70mm	6W		7SRD*A-6□(-T)	7SRD*D-6□(-T)	7SRD*E-6□(-T)	-	-	-	B-223
	10W		7SRD*A-10□(-T)	7SRD*D-10□(-T)	7SRD*E-10□(-T)	-	-	-	B-225
	15W		7SRD*A-15□(-T)	7SRD*D-15□(-T)	7SRD*E-15□(-T)	-	-	-	B-227
80mm	15W		8SRD*A-15□(-T)	8SRD*D-15□(-T)	8SRD*E-15□(-T)	-	-	-	B-229
	25W		8SRD*A-25□(-T)	8SRD*D-25□(-T)	8SRD*E-25□(-T)	-	-	-	B-232
90mm	40W		9SRD*A-40□(-T)	9SRD*D-40□(-T)	9SRD*E-40□(-T)	-	-	-	B-235
	60W		9SRD*A-60F2□(-T)	9SRD*D-60F2□(-T)	9SRD*E-60F2□(-T)	-	-	-	B-238
	90W		9SRD*A-90F2□(-T)	9SRD*D-90F2□(-T)	9SRD*E-90F2□(-T)	-	-	-	B-242
	120W		9SRD*A-120F2□(-T)	9SRD*D-120F2□(-T)	9SRD*E-120F2□(-T)	-	-	-	B-246

Frame Size	Voltage		Speed Control Brake Motor					Page	
	Output		A 1∅ 110V 60Hz	D 1∅ 220V 60Hz	E 1∅ 220~240V 50Hz	G 3∅ 220V 50/60Hz	K 3∅ 380V~400V 50/60Hz		L 3∅ 415V~440V 50/60Hz
80mm	15W		8SBD*A-15□(-T)	8SBD*D-15□(-T)	8SBD*E-15□(-T)	-	-	-	B-251
	25W		8SBD*A-25□(-T)	8SBD*D-25□(-T)	8SBD*E-25□(-T)	-	-	-	B-254
90mm	40W		9SBD*A-40□(-T)	9SBD*D-40□(-T)	9SBD*E-40□(-T)	-	-	-	B-257
	60W		9SBD*A-60F2□(-T)	9SBD*D-60F2□(-T)	9SBD*E-60F2□(-T)	-	-	-	B-260
	90W		9SBD*A-90F2□(-T)	9SBD*D-90F2□(-T)	9SBD*E-90F2□(-T)	-	-	-	B-264
	120W		9SBD*A-120F2□(-T)	9SBD*D-120F2□(-T)	9SBD*E-120F2□(-T)	-	-	-	B-268
	180W		-	9SBD*D-180F2□(-T)	9SBD*E-180F2□(-T)	-	-	-	B-272

1. Enter the output shaft type of motor (G: Gear Type/S: Round Type/D: D-Cut Type/K: Key Type) in the place \* within the motor model name.
2. Enter the model type of attaching Gearbox (G Type/P Type/H Type/W Type/WH Type) in the box (□) within the motor model name.
3. All models contain a built-in thermal protector.

# A Information

## Products Lineup

### AC Motors

Frame Size	Voltage Output	Speed Control Clutch & Brake Motor						Page
		A 1∅ 110V 60Hz	D 1∅ 220V 60Hz	E 1∅ 220~240V 50Hz	G 3∅ 220V 50/60Hz	K 3∅ 380V~400V 50/60Hz	L 3∅ 415V~440V 50/60Hz	
80mm	15W	8CSD*A-15□(-T)	8CSD*D-15□(-T)	8CSD*E-15□(-T)	-	-	-	B-277
	25W	8CSD*A-25□(-T)	8CSD*D-25□(-T)	8CSD*E-25□(-T)	-	-	-	B-279
90mm	40W	9CSD*A-40□(-T)	9CSD*D-40□(-T)	9CSD*E-40□(-T)	-	-	-	B-281
	60W	9CSD*A-60F2□(-T)	9CSD*D-60F2□(-T)	9CSD*E-60F2□(-T)	-	-	-	B-283
	90W	9CSD*A-90F2□(-T)	9CSD*D-90F2□(-T)	9CSD*E-90F2□(-T)	-	-	-	B-285
	120W	9CSD*A-120F2□(-T)	9CSD*D-120F2□(-T)	9CSD*E-120F2□(-T)	-	-	-	B-287

1. G : Gear type is only available.
2. Enter the output shaft type of motor (G: Gear Type / K: Key Type) in the place \* within the motor model name.
3. Enter the model type of attaching Gearbox (G Type/P Type / H Type / WH Type) in the box (□) within the motor model name.
4. All models contain a built-in thermal protector.

### DC Motors

Frame Size	Voltage Output	DC Motor			Page
		DC 12V	DC 24V	DC 90V	
60mm	15W	6DC*12-15-30	6DC*24-15-30	6DC*90-15-30	C-05
80mm	25W	8DC*12-25-30	8DC*24-25-30	8DC*90-25-30	C-07
	40W	8DC*12-40-30	8DC*24-40-30	8DC*90-40-30	C-09
90mm	60W	9DC*12-60-30	9DC*24-60-30	9DC*90-60-30	C-11
	90W	9DC*12-90-30	9DC*24-90-30	9DC*90-90-30	C-13
	120W	9DC*12-120-30	9DC*24-120-30	9DC*90-120-30	C-15

1. Enter the output shaft type of motor in the place \* within the motor model name.  
(D: D-Cut Type/K: Key Type/G: Shaft for G Type Gearbox/P: Shaft for P Type Gearbox/W: Shaft for W Type Gearbox)

### Gearbox

Type	Frame Size	Gearbox Model	Gear Reduction Ratio	Page	
Parallel Gearbox	G Type	60mm	6GBD□MH	3/3.6/5/6/7.5/9/10/12.5/15/18/20/25/30/36/40/50/60/75/90/100/120/150/180/200/250	D-07
		70mm	7GBK□BMH	3/3.6/6/7.5/9/12.5/15/18/25/30/36/50/60/75/90/100/120/150/180	D-07
		80mm	8GBK□BMH	3/3.6/5/6/7.5/9/12.5/15/18/25/30/36/40/50/60/75/90/100/120/150/180/200/250/300/360	D-08
		90mm	9GBK□BMH	2/3/3.6/5/6/7.5/9/10/12.5/15/18/25/30/36/40/50/60/75/90/100/120/150/180	D-09
	P Type	90mm	9PBK□BH/9PFK□BH	2/3/3.6/5/6/7.5/9/12.5/15/18/20/25/30/36/40/50/60/75/90/100/120/150/180	D-10
	H Type	90mm	9HBK□BH/9HFK□BH	3/3.6/6/9/12.5/15/18/20/25/30/36/50/60/75/90/100/120/150/180	D-11
Worm Gearbox	W Type	80mm	8WD□BL/□BR/□BRL	10/12/15/18/25/30/36/50/60	D-13
		90mm	9WD□BL/□BR/□BRL	10/12/15/18/25/30/36/50/60	D-13
	WH Type	90mm	9WHD□-030	7.5/10/15/20/25/30/40/50/60/80	D-14
		90mm	9WHD□-040	50/60/80/100	D-15
		104mm	10WHD□-040	7.5/10/15/20/25/30/40	D-15
Inter-decimal Gearbox	80mm	8XD10□□	10	D-16	
	90mm	9XD10□□	10	D-16	

1. Enter the gear ratio in the box (□) within the Gearbox model name.
2. Enter the model type of attaching Gearbox (G/P/H/W/WH) in the place \*.

## General Information

### How to Read Motor Specifications

Model		Output ① W	Voltage V	Frequency Hz	Poles	Duty	Starting Torque ②		Rated Load				Capacitor μF / VAC
Lead Wire Type	Terminal Box Type						kgfcm	N.m	③ Speed r/min	④ Current A	⑤ Torque kgfcm N.m		
9IDG*~60F□(-T): Gear Type Shaft		60	1ø 110	60	4	Cont.	3.40	0.340	1600	1.40	4.60	0.460	16.0 / 250
9IDD*~60F(-T): D-Cut Type Shaft	9IDGA~60F□-T		1ø 220				4.20	0.420			1600	0.63	
9IDK*~60F(-T): Key Type Shaft	9IDGE~60F□-T	60	1ø 220	50	4	Cont.	3.40	0.340	1300	0.48	4.80	0.480	3.5 / 450
			1ø 240				4.00	0.400			0.54	5.40	
9IDGG~60F□	9IDGG~60F□-T	60	3ø 220	50	4	Cont.	15.00	1.500	1350	0.59	4.60	0.460	-
				60			12.80	1.280			1600	0.49	
9IDGK~60F□	9IDGK~60F□-T	60	3ø 380	50	4	Cont.	17.00	1.700	1350	0.33	4.80	0.480	-
				60			13.80	1.380			1600	0.29	
			3ø 400	50	4	Cont.	18.60	1.860	1350	0.36	5.20	0.520	
				60			15.20	1.520			1600	0.30	
			3ø 415	50	4	Cont.	20.00	2.000	1350	0.40	5.60	0.560	
				60			16.20	1.620			1600	0.33	
			3ø 440	50	4	Cont.	22.00	2.200	1350	0.44	6.00	0.600	
				60			18.20	1.820			1600	0.36	

- ① Output: The amount of work that can be performed in a given period of time. It can be used as a criterion for motor capability.
- ② Starting Torque: This term refers to the torque generated the instant the motor starts. If the motor is subjected to a friction load smaller than this torque, it will operate.
- ③ Speed: This is the speed of the motor when the motor is producing rated torque.
- ④ Current: The current value used by a motor when the motor is producing rated torque.
- ⑤ Torque: This is the torque created when the motor is operating most efficiently. Though the maximum torque is far greater, rated torque should, from the standpoint of utility, be the highest torque.

### How to Read Gearbox Specifications

#### 60Hz

Motor Model	Gearbox Model	감속비	2	3	3.6	5	6	7.5	9	12.5	15	18	20
		② r/min	900	600	500	360	300	240	200	144	120	100	90
9IDG□~60FP	9PBK□BH 9PFK□BH	kgfcm	7.0	10.5	12.5	17.4	20.9	26.1	31.4	39.4	47.3	56.7	57.1
		N.m	0.68	1.02	1.23	1.71	2.05	2.56	3.07	3.86	4.63	5.56	5.60
9IDG□~60FH	9HBK□BH 9HFK□BH	kgfcm	③ -	10.5	12.5	-	20.9	-	31.4	39.4	47.3	56.7	57.1
		N.m	-	1.02	1.23	-	2.05	-	3.07	3.86	4.63	5.56	5.60

Motor Model	Gearbox Model	감속비	25	30	36	40	50	60	75	90	100	120	150	180
		r/min	72	60	50	45	36	30	24	20	18	15	12	10
9IDG□~60FP	9PBK□BH 9PFK□BH	kgfcm	71.4	85.7	102.8	114.2	142.8	171.4	192.2	200.0	200.0	200.0	200.0	200.0
		N.m	7.00	8.40	10.08	11.20	13.99	16.79	18.83	19.60	19.60	19.60	19.60	19.60
9IDG□~60FH	9HBK□BH 9HFK□BH	kgfcm	71.4	85.7	102.8	-	142.8	171.4	192.2	230.6	256.2	300.0	300.0	300.0
		N.m	7.00	8.40	10.08	-	13.99	16.79	18.83	22.60	25.11	29.40	29.40	29.40

- ① Permissible Torque: It refers to the value of load torque driven by the Gearbox's output shaft. Each value is shown for the corresponding gear ratio.
- ② r/min: This refers to the speed of rotation in the Gearbox output shaft. The speeds, depending on gear ratio, are shown in the permissible torque table when the Gearbox is attached. The speed is calculated by dividing the motor's synchronous speed (50Hz: 1,500r/min, 60Hz: 1,800r/min) by the gear ratio. The actual speed, according to the load condition, is 2~20% less than the displayed value.
- ③ Direction of Rotation: This refers to the direction of rotation viewed from the output shaft. The colored background areas indicate rotation in the same direction as the motor shaft, while the others rotate in the opposite direction. The direction of Gearbox shaft rotation may differ from motor shaft rotation depending on the gear ratio of the Gearbox.



# A Information

## General Information

### Permissible Load Inertia

'J' and 'GD<sup>2</sup>' is used to describe the moment of inertia. J is generally called inertia and has the same value of physical moment of inertia in SI units. Unit is in kg·m<sup>2</sup>. GD<sup>2</sup> is called 'flywheel effect' and generally used in industrial application with gravitational systems of units. Unit is in kgf·m<sup>2</sup> or kgf·cm<sup>2</sup>. A relation between J and GD<sup>2</sup> is described as:  $J = GD^2 / 4$

### Calculation of Permissible Load Inertia

When the load inertia J connected to the Gearbox is large, frequent starting of the motor or electromagnetic brake generates a large torque. If this impact is excessive, it may damage the Gearbox and the motor. Inertia varies with types of the load and the inertia of the load significantly affects life expectancy of gear and electromagnetic brake. When applying the braking force by using the electromagnetic brake, do not exceed a permissible load inertia set for a specific model.

#### Permissible Inertia at Motor Shaft

$$J_M = J_G \times \frac{1}{i^2}$$

**J<sub>G</sub>** : Inertia of Gearbox output shaft (kg·cm<sup>2</sup>)

**J<sub>M</sub>** : Permissible inertia at motor shaft (kg·cm<sup>2</sup>)

**i** : Gear reduction ratio (e.g. 5 if the ratio is 1/5)

#### Permissible Load Inertia Moment at Gearbox Output Shaft

**J<sub>G</sub>** = J<sub>M</sub> × i<sup>2</sup> (when reduction ratio is 1/3 to 1/50)

**J<sub>G</sub>** = J<sub>M</sub> × 2500 (when reduction ratio is 1/60 or larger)

**J<sub>G</sub>** : Permissible load inertia moment at Gearbox output shaft (kg·cm<sup>2</sup>)

**J<sub>M</sub>** : Permissible inertia at motor shaft (kg·cm<sup>2</sup>)

**i** : Gear reduction ratio (e.g. 5 if the ratio is 1/5)

### Motor and Load Inertia

The equation of motion is described as below when the inertia load is driven by the motor.

$$T = J\alpha = J \cdot \frac{d\omega}{dt} = \frac{GD^2}{4} \cdot \frac{d\omega}{dt} = \frac{2\pi}{60} \cdot \frac{GD^2}{4} \cdot \frac{dn}{dt}$$

**T** : Torque (N·m)

**J** : Moment of inertia (kg·m<sup>2</sup>)

**ω** : Angular speed (rad/s)

**t** : Time (s)

**n** : Rotational speed (r/s)

**GD<sup>2</sup>** : Flywheel Effect (GD<sup>2</sup> = 4J)

**g** : Flywheel Effect (GD<sup>2</sup> = 4J)

**α** : Angular acceleration (rad/s<sup>2</sup>)

- In the case of induction motor, torque generated at the starting varies depending on the speed. Therefore, an average acceleration torque is generally used, which is the averaged torque from the starting and the constant speed.

- A necessary average acceleration torque T<sub>A</sub> to accelerate the load inertia of J(kg·cm<sup>2</sup>)/GD<sup>2</sup>(kgf·cm<sup>2</sup>) up to a speed n(min<sup>-1</sup>) in time t(s) can be obtained by the following formula.

#### SI Units

$$T_A = \frac{J}{9.55 \times 10^4} \times \frac{N}{t} \quad (\text{N} \cdot \text{m})$$

#### Gravitational System of Units

$$T_A = \frac{GD^2}{3750000} \times \frac{N}{t} \quad (\text{kgf} \cdot \text{cm})$$

### Calculation of Flywheel Effect (GD<sup>2</sup>)

<b>Disk</b> 	$GD^2 = \frac{1}{2} WD^2 \text{ (kgf} \cdot \text{cm}^2)$ <p>W: Weight [kgf] D: Outer diameter [cm]</p>	<b>Hollow Circular Cylinder</b> 	$GD^2 = \frac{1}{2} W(D^2 + d^2) \text{ (kgf} \cdot \text{cm}^2)$ <p>W: Weight [kgf] D: Outer diameter [cm] d: Inner diameter [cm]</p>
<b>Sphere</b> 	$GD^2 = \frac{2}{5} WD^2 \text{ (kgf} \cdot \text{cm}^2)$ <p>W: Weight [kgf] D: Diameter [cm]</p>	<b>Cube</b> 	$GD^2 = \frac{1}{3} W(a^2 + b^2) \text{ (kgf} \cdot \text{cm}^2)$ <p>W: Weight [kgf] a,b: Length of side [cm]</p>
<b>Slender Round Bar</b> 	$GD^2 = \frac{3D^2 + 4L^2}{12} \text{ (kgf} \cdot \text{cm}^2)$ <p>W: Weight [kgf] D: Outer diameter [cm] L: Length [cm]</p>	<b>Straight bar</b> 	$GD^2 = \frac{4}{3} WL^2 \text{ (kgf} \cdot \text{cm}^2)$ <p>W: Weight [kgf] L: Length [cm]</p>
<b>Discrete Shaft</b> 	$GD^2 = \frac{1}{2} WD^2 + 4WS^2 \text{ (kgf} \cdot \text{cm}^2)$ <p>W: Weight [kgf] D: Diameter [cm] S: Turning radius [cm]</p>	<b>Horizontal Linear Motion</b> 	$GD^2 = WD^2 \text{ (kgf} \cdot \text{cm}^2)$ <p>W: Weight on the conveyor [kgf] D: Drum diameter [cm] * GD<sup>2</sup> of drum not included</p>
<b>Ball Screw</b> 	$GD^2 = GD^2_A + \frac{W \cdot P^2}{\pi^2} \text{ (kgf} \cdot \text{cm}^2)$ <p>W: Weight [kgf] P: Lead of feed screw [cm] GD<sup>2</sup>A: GD<sup>2</sup> of feed screw [kgf·cm<sup>2</sup>]</p>	<b>Reducer</b> 	Equivalent all GD <sup>2</sup> on axis 'a' $GD^2 = GD^2_1 + \left(\frac{n2}{n1}\right)^2 GD^2_2 \text{ (kgf} \cdot \text{cm}^2)$ <p>n1: Speed of axis 'a' [min<sup>-1</sup>] n2: Speed of axis 'b' [min<sup>-1</sup>] GD<sup>2</sup>1: GD<sup>2</sup> of axis 'a' [kgf·cm<sup>2</sup>] GD<sup>2</sup>2: GD<sup>2</sup> of axis 'b' [kgf·cm<sup>2</sup>]</p>

### Permissible Load Inertia at Motor Shaft

Frame Size	Output	Permissible Load Inertia GD <sup>2</sup> (kgfcm <sup>2</sup> )
□60mm	6W	0,25
□70mm	15W	0,56
□80mm	15W, 25W	1,24
□90mm	40W	3,00
	60W	4,40
	90W, 120W, 150W	4,40
	180W, 200W	6,00

# A Information

## General Information

### Calculation Method of Motor Capacity

For the calculation way of load torque, refer to below for the reference. According to this, needed motor sizing is decided. Be advised that basic calculation way is referred below. So in real sizing consider the acceleration time in start, needed power, safety index in design and manufacturing and the influence by voltage fluctuation and select motor considering.

#### Belt Conveyor Application

$$T = \frac{1}{2} D(F + \mu W) \text{ [kgf} \cdot \text{cm]}$$

- D : Diameter of drum [cm]
- W : Weight [kgf]
- $\mu$  : Friction coefficient
- F : External force [kgf]

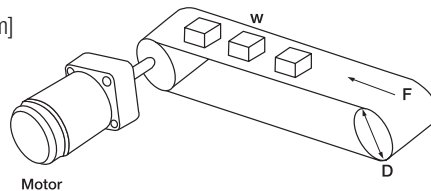

#### Hoisting Application

$$T = \frac{1}{2} D \cdot W \text{ [kgf} \cdot \text{cm]}$$

- D : Diameter of drum [cm]
- W : Weight [kgf]

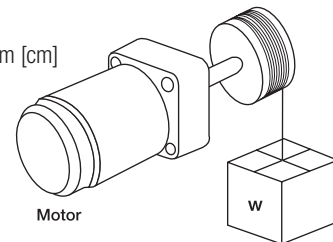

#### Flywheel Application

$$T = \frac{GD^2}{37500} \times \frac{N}{t} \text{ [kgf} \cdot \text{cm]}$$

- N : Revolutions per minute [r/min]
- $GD^2$  : Flywheel effect [kgfcm<sup>2</sup>]
- t : Time [sec]

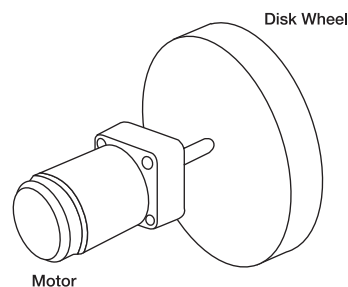

#### Horizontal Travel on Contact Face

$$T = \frac{1}{2} D \cdot \mu W \text{ [kgf} \cdot \text{cm]}$$

- W : Weight [kgf]
- $\mu$  : Friction coefficient
- D : Diameter of wheel

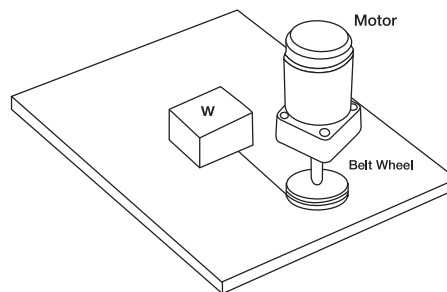

#### Ball Screw Drive

$$T = \frac{1}{2\pi} P \cdot (F + \mu W) \text{ [kgf} \cdot \text{cm]}$$

- F : External force [kgf]
- W : Weight [kgf]
- $\mu$  : Friction coefficient of sliding surfaces (approx. 0.05 to 0.2)
- P : Lead of ball screw [cm]

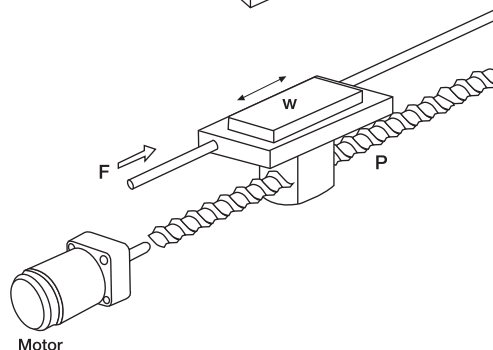

## Terminology

### Motor

#### Alternating Current (AC)

- AC, which is different than DC, is the current coming from the power supply so that positive (+) pole and negative (-) pole can cross with regular time interval, and becomes current sine wave which the direction of current and voltage has regular period and is changed. In other words, this appears as if the pendulum swings from left to right with the constant rhythm.

#### Direct Current (DC)

- DC is the current coming from the power supply that positive (+) pole and negative (-) pole is constant all the times, and the direction is invariable and the size is also constant.
- The direction of voltage is constant.
- DC generation device includes various rectifiers such as battery, storage battery, and DC generator.

#### Frequency (F)

- Frequency is the times of vibration that AC repeats for 1 second.
- The unit is Hertz (Hz).
- In Korea, 60Hz frequency is employed as a standard which means that the direction of current changes from (+) to (-) 60 times for 1 minute.

#### Rating

- This means what is designed to be suitable for the requirements specified in the motor and when satisfied with the use conditions, the use limit is called 'rating'.
- This designates voltage, current, r/min, frequency which determine the use limit for output. We call it rated output, rated voltage, rated current, rated r/min, and rated frequency.
- Rating includes continuous rating, short-time rating and intermittent periodic rating.

##### Continuous Rating

- When using continuously under the designated condition, if it is available to use continuously without exceeding the prescribed temperature rising and general condition, it is called 'continuous rating'. (e.g. Induction motor)

##### Short-time Rating

- When operating during the prescribed time under the designated condition, if it is available to use without exceeding the prescribed temperature rising and general condition, it is called 'short-time rating'. (e.g. Reversible motor)

##### Intermittent Periodic Rating

- When repeating run and stop periodically with constant load under the prescribed condition, if it is available not exceed general condition such as the prescribed temperature rising etc., it is called 'intermittent periodic rating'.

#### Output

- Output is the thing which can be done by motor during the unit time and it is determined by r/min x torque. The value of rated output is indicated as follows:

$$\text{Output} = 1.027 \times T \times N \text{ [WATTS]}$$

**T:** TORQUE [kgf·m]

**N:** Number of rotation [r/min]

- Rated output: It indicates the output which is generated continuously under the condition of designated voltage and frequency. This designated voltage and frequency is called the rated voltage and rated frequency. At this time, the rated output is called generally the output of motor.



# A Information

## Terminology

### ☐ Torque and r/min

- Torque of motor is the revolution force to turn the body of revolution. The unit is [gf·cm] or [kgf·cm] and SI unit is N.m.
- The torque of 1kgf·cm is the revolution force when 1kg of force is applied to the right angle from the point of outer circle which radius of the body of revolution is 1cm.

#### ● Starting Torque (① in figure 1)

- This is the revolving force generated when motor starts and is called 'locked rotor torque' or 'starting torque'.
- If the bigger force than this torque is applied to the motor, the motor does not revolve.

#### ● Stalling Torque (② in figure 1)

- The maximum torque of motor is breakdown torque.
- If there is a load more than maximum torque during operation, motor will stop.

#### ● Rated Torque (③ in figure 1)

- It is the torque when the motor is the rated r/min.
- The torque when the rated output is generated continuously by applying the rated voltage to the motor.

#### ● Synchronous Speed (④ in figure 1)

- It is r/min which is determined by the power frequency and the number of pole of motor.

$$NS = 120f/P \text{ [r/min]}$$

**NS** : Synchronous r/min [r/min]

**P** : The number of pole of motor

**f** : Power frequency [Hz]

**120** : Constant number

**r/min** : Revolution per minute

#### ● No Load Speed (⑤ in figure 1)

- It is r/min when motor revolves without applying any load to motor output shaft.
- In this case, motor revolves low about 20~80[r/min] than synchronous r/min in Induction Motor or Reversible Motor.

#### ● Rated Speed (⑥ in figure 1)

- It is r/min when rate r/min is generated by applying the rated load to the motor, and the most ideal r/min in use.

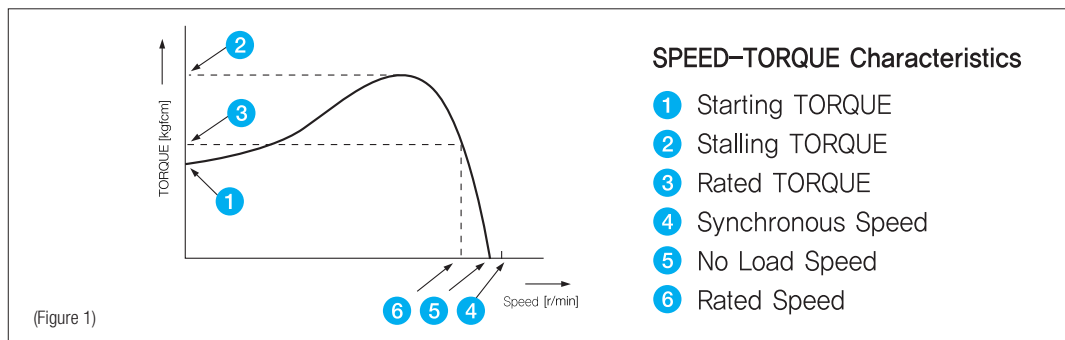

### ☐ Slippage

- Slippage can be described in the following formula as one of the rotational speed.

$$S = \frac{NS - N}{NS} \text{ or } N = NS \times (1 - S)$$

**NS** : Synchronous r/min [r/min]

**N** : r/min at Temporary load [r/min]

**S** : SLIP

For example, if induction motor with 4 pole and 60Hz operates at SLIP  $S=0.1$ ,

$$N = \frac{120 \times 60}{4} \times (1 - 0.1) = 1620 \text{ [r/min]}$$

### ☉ Permissible Torque

- It is the maximum torque available when operating the motor. This is limited by rated torque of motor, temperature rising, and the strength of Gearbox to combine.

### ☉ Overrun

- This is the angle (r/min) that indicates the excessive revolution of motor from the moment of power shutdown to the stop.

## ☉ Gearbox

### ☉ Gear Reduction Ratio

- Gearbox is a speed converter using a gear and an instrumental device to reduce the r/min of motor into the required r/min and get bigger torque. Gear reduction ratio is a rate in which the Gearbox decelerates the motor's r/min.
- There are two groups of gear reduction ratio; one is for 3, 5, 7.5, 12.5, 15... and the other is 3.6, 6, 9, 15, 18... which are 1.2 times the previous group so that you can obtain approx. the same output speed for both 50Hz and 60Hz.

### ☉ Maximum Permissible Torque

- It is maximum load torque which can be applied to the output shaft of the Gearbox.
- It is determined by the mechanical strength such as material of Gearbox, gear teeth and bearing and the size of Gearbox as well as the gear reduction ratio.

### ☉ Transmission efficiency

- It is an efficiency with which motor torque is increased by the Gearbox and described in %.
- It is determined by the bearing, friction of the gear tooth and resistance of lubricating oil.
- In general, this efficiency is approx. 90% per stage of the gear. If gear ratio is higher, the number of gear will increase and the efficiency rate will decrease.

### ☉ Service Factor

- It is a coefficient which is used to estimate the service life of the Gearbox.
- This value is generally derived from experience and based on type of the load and operating conditions.
- The life of a Gearbox during particular application is estimated by dividing the standard life expectancy by the service factor.

### ☉ Overhung Load

- Overhung load is defined as a load applied to the output shaft in the right-angle direction.
- Maximum value of the overhung load which is applicable to the shaft is called as 'permissible overhung load'. This value varies depending on the type of Gearbox and the distance from the edge of the shaft.

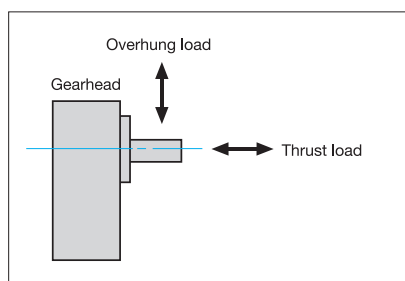

### ☉ Thrust Load

- The thrust load is defined as a load applied to the output shaft in the axial direction.
- Maximum value of the thrust load which is applicable to the shaft is called as 'permissible thrust load'. This value varies depending on the type of the Gearbox.

# A Information

## Caution for Using

Before using, read safety precautions carefully and use products properly. For the suggestions on using, they are classified as caution and warning.

### ▲ Caution

- Make sure to check whether the things are what you ordered. If you install the other thing, there may occur the injury and/or the fire.
- The motor and the controlling unit should be used only by the designated compounding. If not, the fire may occur.
- The motor should be used after it is fixed tightly. If not, the injury and/or the damage of the unit may occur.
- Make sure to check the rotating direction before connecting the machine. If not, the injury and/or the damage of the unit may occur.
- In case of connecting with the machine and beginning to operate, do in the state of emergency stop anytime. If not, the damage will occur.
- Use products only according to the specification of motor and controlling unit. If not, there will be dangerous fire, electric shock, injury and/or damage of the unit.
- Do not place any obstacle around motor which can disturb circulation of air. It could be cause of overheating or breakdown.
- Do not put the fingers or things into the outlet of the unit. There may be electric shock, injury or danger of fire.
- Do not operate with the wet hands. The electric shock may occur.
- In case of moving, do not catch the output shaft, connecting part or the lead wire. There may be the injury by the drop.
- Do not touch the rotating part (output shaft, cooling fan) in running. It could be cause of injury.
- Do not touch the side of the motor output shaft (key way, cutting part) with the naked hands. It could be cause of injury.
- Make sure to install the overload device because the protection device is not attached to the motor. It is desirable to install other protection devices other than overload protection device to prevent fire.
- Electromagnetic brake is not for holding the load certainly and it doesn't hold the load if thermal protector (TP) works. So if the safety brake is needed, install another braking system.
- If there are abnormal cases, turn off the power at once. If not, there will be the electric shock, injury and the damage.
- In operating and right after the operation, do not touch the controlling device by your hands or body. The fire will occur.
- In scrap of motor, disassemble and treat it as industrial waste as possible.

### ▲ Warning

- Never put around the explosive atmosphere, gas to be burnt, corrosive air, the location to be wet and combustibles. If not, there will be the electric shock and the fire.
- In case of movement, connection and checking of motor please turn off the electric power.
- Make sure to connect motor and speed controller based on the connection diagram. If not, there will be the electric shock and the fire.
- The power cable and the lead wire should not be bent, pulled and inserted by force. If not, the electric shock and the fire may occur.
- In case of the motor and controlling unit are attached to the machine, never touch with hand or connect with the earth. If not, the electric shock may take place.
- Never operate in the state of exposing the flowing current. If not, the electric shock may take place.
- In case of interruption of electric power and wiring the protection of overheat, please turn off the power. When motors are working continuously, there may be injury and damage of the unit.
- Within the 30 seconds after the power off, do not touch the output terminal of the controlling unit. If not, the electric shock may occur because of the residual volts.

