

# Ezi-STEP<sup>®</sup>

## Micro Stepping System

---

- Motor + Drive + Controller + Network
- Embedded Controller
- Micro Stepping
- Software Damping
- Run/Stop Signal Output

**ALL**





*Fast, Accurate, Smooth Motion*

# **Ezi-STEP**® **ALL**

**Micro Stepping System**

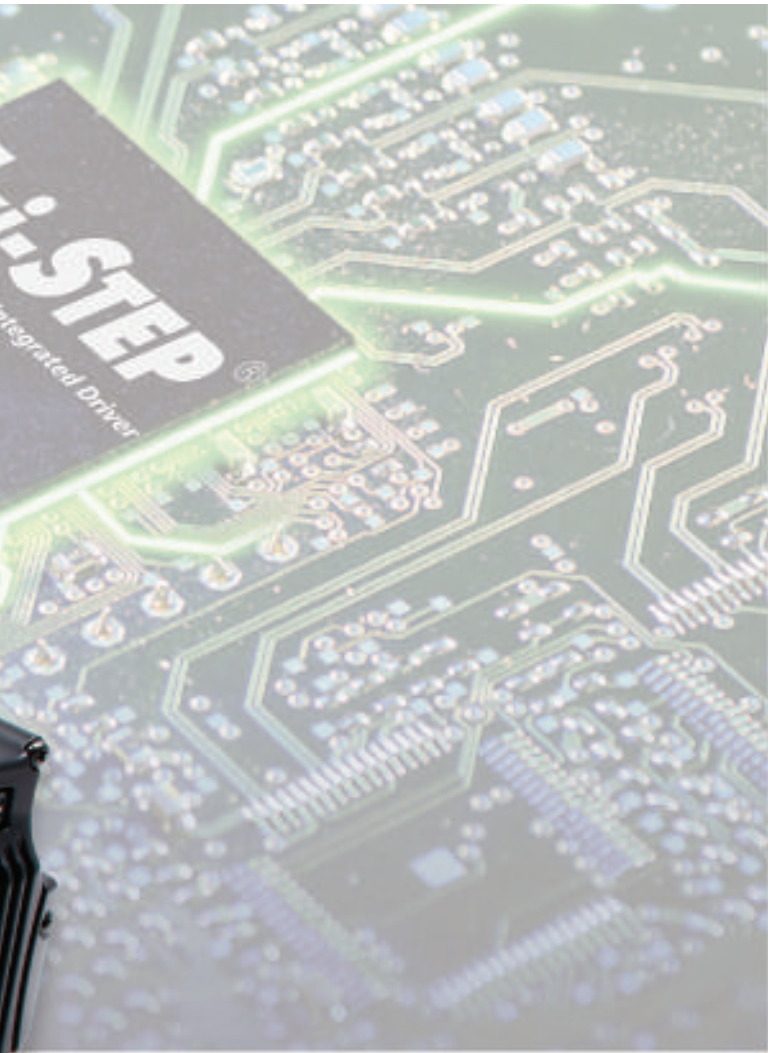

## 2 Position Table Function

Position Table can be used for motion control by digital input and output signals of host controller.

You can operate the motor directly by sending the position table number, start/stop, origin search and other digital input values from a PLC.

The PLC can monitor the origin search, moving/stop, servo ready and other digital output signals from a drive. A maximum of 64 positioning points can be set from PLC.



## 1 Network Based Motion Control

A maximum of 16 axis can be operated from a PC through RS-485 communications. All of the Motion conditions are set through the network and saved in Flash ROM as a parameter. Motion Library(DLL) is provided for programming under Windows 7/8/10.



## 3 Microstep and Filtering

High precision Microstep function and Filtering

The high-performance MCU operates at step resolutions of  $1.8^\circ$  up to maximum  $0.0072^\circ$  (1/250 steps) and Ezi-STEP adjusts PWM control signal in every  $25 \mu\text{sec}$ , which makes it possible for more precise current control, resulting in high-precision Microstep operation.

## 4

### Software Damping

#### Vibration suppression and high-speed operation

Vibration suppression and High-speed operation (Patent pending) Motor vibration is created by magnetic flux variations of the motor, lower current from the drive due to back-emf from the motor at high speeds and lowering of phase voltages from the drive.

Ezi-STEP drive detects these problems and the MCU adjusts the phase of the current according to the pole position of the motor, drastically suppressing vibration. This allows the smooth operation of the motor at high speeds.

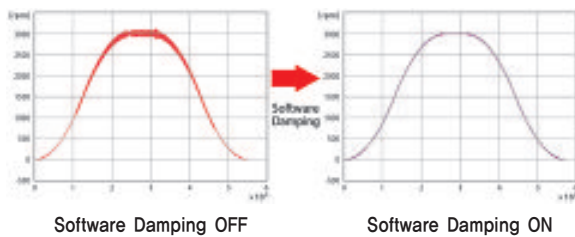

※ This is real measured speed that using 100,000 [pulse/rev] encoder.

# ● Features of Motion Controller

## 1. Loop Count

This function allows positioning repeatedly according to the Loop Count Number.

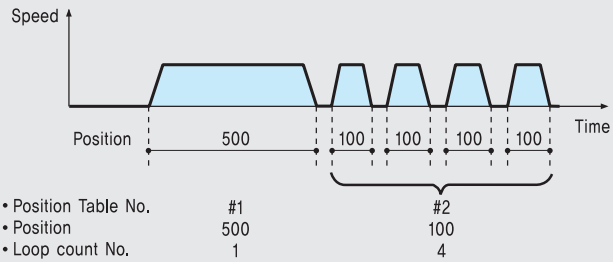

## 2. Acceleration/Deceleration

For quick acceleration and gradual deceleration, you can set each acceleration and deceleration time separately.

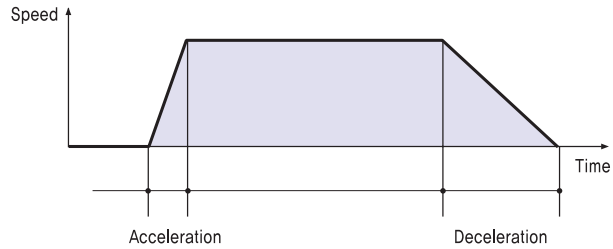

## 3. Pause

You can pause the motion upon the input of an external signal. When Pause signal change to OFF, the motor will restart to original target position.

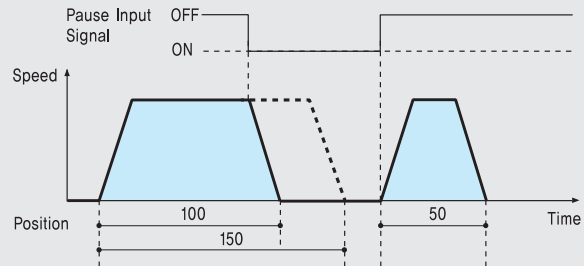

## 4. Alarm

The number of 7-Segment flashing time indicates which Alarm has occurred.



## 5. Teaching

Teaching signal is used to memorize current Position data into the selected Position Table item.

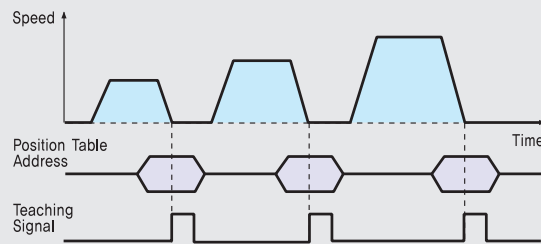

## 6. Jump

Within one Position Table, you can select various Position Table numbers that you want to jump. With three external input signal during movement, the next jump Position Table number can be select.

◆ Position Table #14

Position	---	Next	---	Input 1	Input 2	Input 3	---
10000		32		60	61	62	

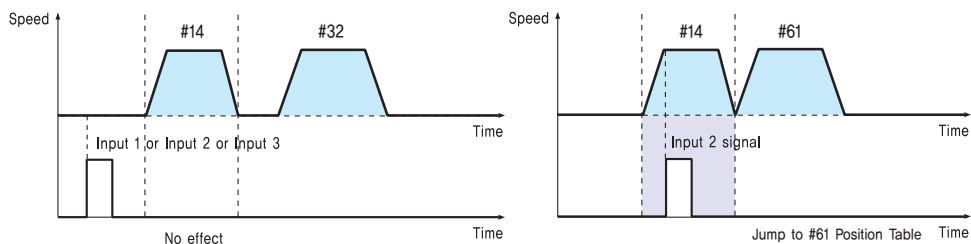

## ● Ezi-STEP ALL Part Numbering

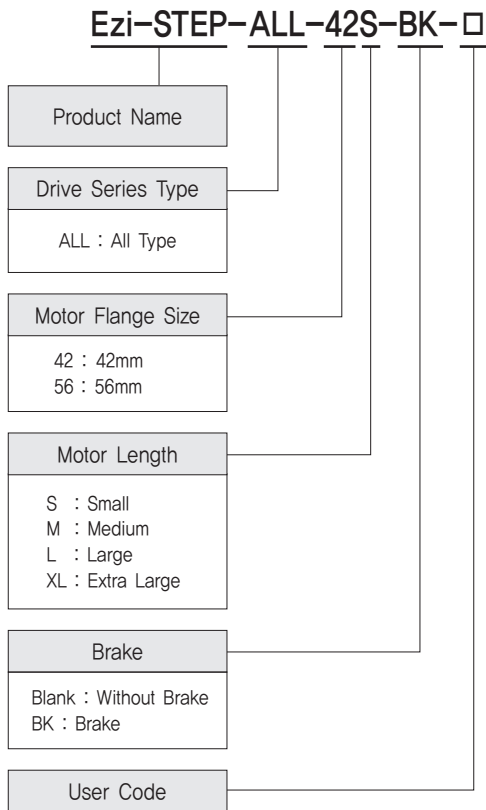

## ● Standard Combination

Unit Part Number	Motor Model Number	Drive Model Number
Ezi-STEP-ALL-42S	Motor & Drive Integrated	
Ezi-STEP-ALL-42M		
Ezi-STEP-ALL-42L		
Ezi-STEP-ALL-42XL		
Ezi-STEP-ALL-56S		
Ezi-STEP-ALL-56M		
Ezi-STEP-ALL-56L		

## ● Combination with Brake

Unit Part Number	Motor Model Number	Drive Model Number
Ezi-STEP-ALL-42S-BK	Motor & Drive Integrated	
Ezi-STEP-ALL-42M-BK		
Ezi-STEP-ALL-42L-BK		
Ezi-STEP-ALL-42XL-BK		
Ezi-STEP-ALL-56S-BK		
Ezi-STEP-ALL-56M-BK		
Ezi-STEP-ALL-56L-BK		

## ● Specifications of Drive

	Input Voltage	24VDC $\pm$ 10%
	Control Method	Bipolar PWM drive with 32bit MCU
	Multi Axes Drive	Maximum 16 axes through Daisy-Chain
	Position Table	64 motion command steps (Continuous, Wait, Loop, Jump and External start etc.)
	Current Consumption	Max 500mA (Except motor current)
Operating Condition	Ambient Temperature	· In Use: 0~50°C · In Storage: -20~70°C
	Humidity	· In Use: 35~85% RH (Non-Condensing) · In Storage: 10~90% RH (Non-Condensing)
	Vib. Resist.	0.5g
Function	Rotation Speed	0~3,000 [rpm]
	Resolution [ppr]	500 1,000 1,600 2,000 3,200 3,600 4,000 5,000 6,400 8,000 10,000 20,000 25,000 36,000 40,000 50,000 (Selectable by parameter) * Default: 10,000
	Protection Functions	Over Current Error, Over Speed Error, Step Out Error, Over Temperature Error, Over Regenerated Voltage Error, Motor Connect Error, Motor Voltage Error, System Error, ROM Error
	7-Segment	Power, Alarm, Communication ID
	STOP Current	10%~100% (Selectable by parameter) Be setted to set value of STOP current after 0,1 second after motor stop. * Default: 50%
	Rotational Direction	CW/CCW (Selectable by parameter) Used when changing the direction of motor rotate. * Default: CW
I/O Signal	Input Signals	3 dedicated inputs (LIMIT+, LIMIT-, ORIGIN), 7 programmable inputs (Photocoupler)
	Output Signals	1 dedicated output (Compare Out), 1 programmable output (Photocoupler), Brake
	Communication Interface	RS-485 serial communication Communication speed: 9,600~921,600[bps]
	Position Control	· Incremental mode / Absolute mode Data Range: -137,217,728 ~ 134,217,727 [pulse] · Operating speed: Max. 3,000 [rpm]
	Return to Origin	Origin Sensor, $\pm$ Limit sensor
	GUI	User Interface Program within Windows
	Software	Motion Library (DLL) for Windows 7/8/10

## ● Specifications of Motor

MODEL		UNIT	Ezi-STEP-ALL-42 series				Ezi-STEP-ALL-56 series			
			42S	42M	42L	42XL	56S	56M	56L	
DRIVE METHOD		-	BI-POLAR							
NUMBER OF PHASES		-	2	2	2	2	2	2	2	
CURRENT per PHASE		A	1,2	1,2	1,2	1,2	3,0	3,0	3,0	
HOLDING TORQUE		N·m	0,32	0,44	0,5	0,65	0,64	1,0	1,5	
ROTOR INERTIA		g·cm <sup>2</sup>	35	54	77	114	180	280	520	
WEIGHTS		g	250	280	350	500	500	720	1150	
LENGTH(L)		mm	34	40	48	60	46	55	80	
PERMISSIBLE OVERHUNG LOAD (DISTANCE FROM END OF SHAFT)	3mm	N	22	22	22	22	52	52	52	
	8mm		26	26	26	26	65	65	65	
	13mm		33	33	33	33	85	85	85	
	18mm		46	46	46	46	123	123	123	
PERMISSIBLE THRUST LOAD		N	Lower than motor weight							
INSULATION RESISTANCE		Mohm	100 MIN,(at 500VDC)							
INSULATION CLASS		-	CLASS B(130°C)							
OPERATING TEMPERATURE		°C	0 to 55							



## Torque Characteristics of Motor

Ezi-STEP-ALL-42 series

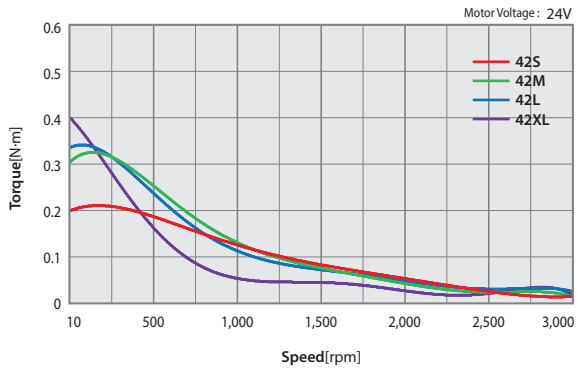

Ezi-STEP-ALL-56 series

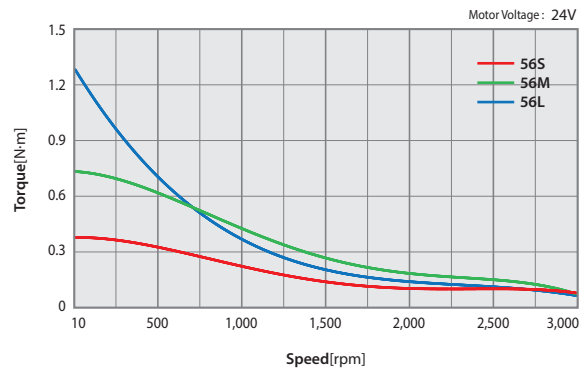

## Dimensions of Motor [mm]

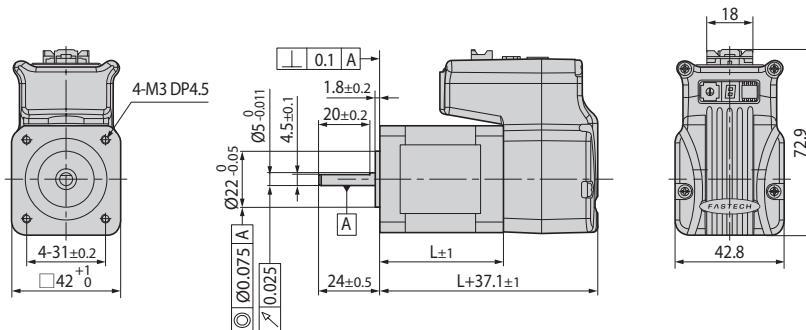

**42mm**

Model name	Length(L)
42S	34
42M	40
42L	48
42XL	60

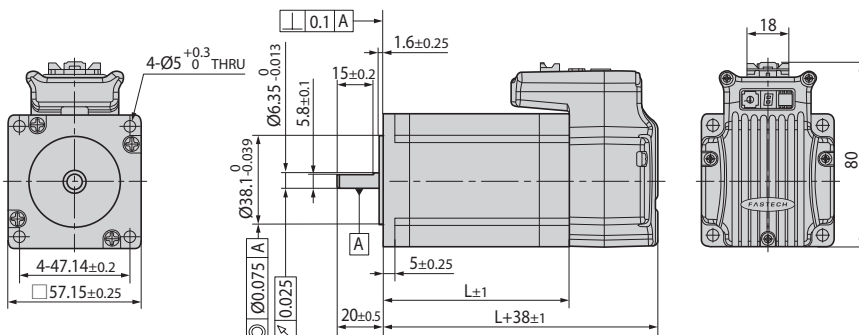

**56mm**

Model name	Length(L)
56S	46
56M	55
56L	80

## ● Specifications of Motor with Brake

Unit Part Number	Motor Model Number	Electronic Brake					Motor Unit Weight [g]	Permitted Overhung Load [N]				Permitted Thrust Load [N]
		Type	Voltage Input [V]	Rated Current [A]	Power Consumption [W]	Statical Friction Torque [N·m]		Length from Motor Point [mm]				
								3	8	13	18	
Ezi-STEP-ALL-42S-BK	Motor & Drive Integrated	Non-excitation run Type	24VDC ±10%	0,2	5	0,2	560	22	26	33	46	Must be Lower than Unit's Weight
Ezi-STEP-ALL-42M-BK							630					
Ezi-STEP-ALL-42L-BK							690					
Ezi-STEP-ALL-42XL-BK				820								
Ezi-STEP-ALL-56S-BK				0,27	6,6	0,7	1090					
Ezi-STEP-ALL-56M-BK							1250					
Ezi-STEP-ALL-56L-BK							1690					

- \* Electronic Brake cannot be used for braking. Position hold purpose only when power OFF.
- \* The weight means Motor Unit Weight including Motor and Electronic Brake.
- \* Motor Model Number is combined model name of Motor and Brake.
- \* Motor specification and torque characteristic are same as Standard Motor.

### \* Brake Operation Timing Chart

Ezi-STEP ALL control Brake by Drive automatically. Please refer to right Timing Chart when control Brake from upper controller other than using Ezi-STEP ALL Brake control. Otherwise, Drive malfunctioning and loads can be fall down. Also, please do not operate Brake while motor operation to prevent damage.

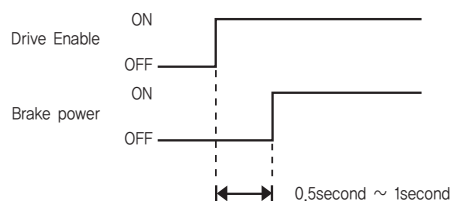

## ● Dimensions of Motor with Brake [mm]

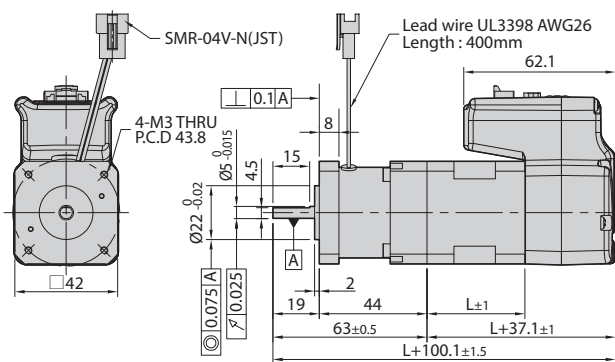

# 42mm

Model Name	Length(L)	Weight(kg)
BM-42S	34	0,56
BM-42M	40	0,63
BM-42L	48	0,69
BM-42XL	60	0,82

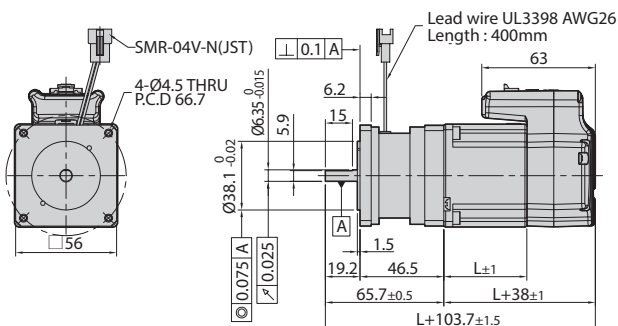

# 56mm

Model Name	Length(L)	Weight(kg)
BM-56S	46	1,09
BM-56M	55	1,25
BM-56L	80	1,69

# Settings and Operation

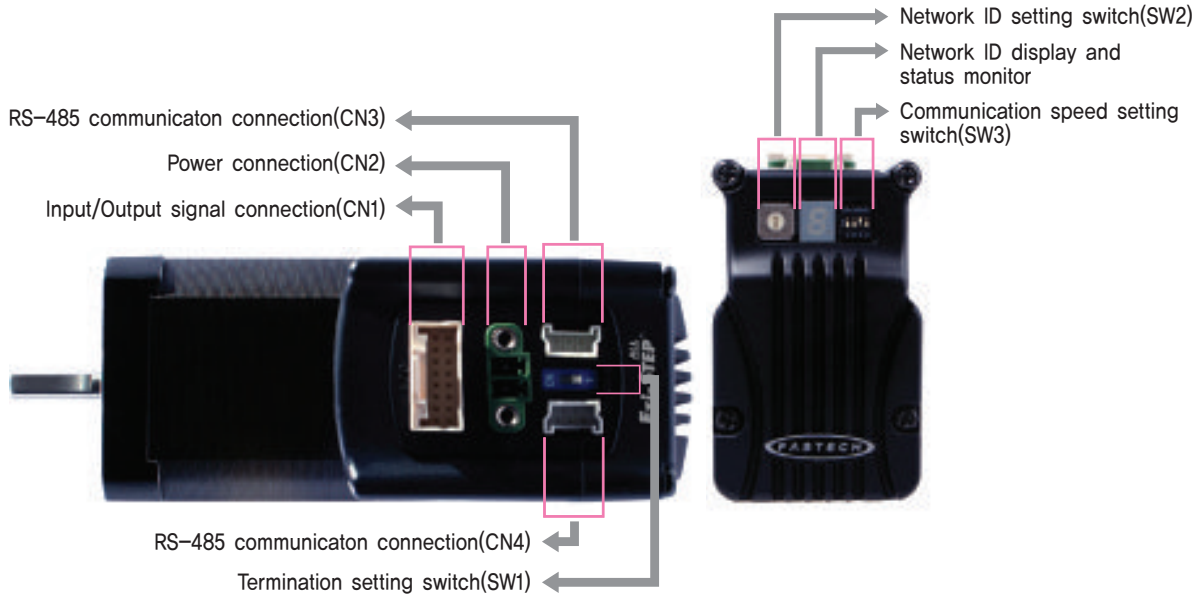

## ◆ Protection functions and 7-Segment flash times

Times	Protection	Conditions
1	Over Current Error	The current through power devices in drive exceeds 4.8A
2	Over Speed Error	Motor speed exceed 3,000 [rpm]
3	Step Out Error	Abnormally motor do not followed pulse input
5	Over Temperature Error	Internal temperature of a motor drive exceeded 85°C
6	Over Regenerative Voltage Error	Back EMF more than 50V
7	Motor Connect Error	Power is ON without connection of motor cable to drive
9	Motor Voltage Error	Motor voltage is below 20V
11	System Error	Error occurs in drive system
12	ROM Error	Error occurs in parameter storage device(ROM)



7-Segment flash(Ex, Step Out Error)

### 1. Termination Setting Switch(SW1)

The drive installed at the end of the network must be terminated for reliable operation. Please termination setting switch is ON if drive install at the end of the network

### 2. Network ID Setting Switch(SW2)

Position	ID Number	Position	ID Number
0	0	8	8
1	1	9	9
2	2	A	10
3	3	B	11
4	4	C	12
5	5	D	13
6	6	E	14
7	7	F	15



※Maximum 16 axis can be connected in one network.

### 3. Communication Speed Setting Switch(SW3)

The purpose of this is to setting the communication speed

SW3.1	SW3.2	SW3.3	Baud Rate [bps]
OFF	OFF	OFF	9,600
ON	OFF	OFF	19,200
OFF	ON	OFF	38,400
ON	ON	OFF	57,600
OFF	OFF	ON	115,200*1
ON	OFF	ON	230,400
OFF	ON	ON	460,800
ON	ON	ON	921,600

※ Possible to use common PCI Bus type RS-485 communication board for High speed communication, (Please contact with Distributor)

\*1 : Default setting value

\*2 : SW3.4 is not available to use

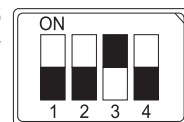

#### 4. Input/Output Signal Connector(CN1)

NO.	Function	I/O
1	EXT_24VDC	Input
2	EXT_GND	Input
3	BRAKE+	Output
4	BRAKE-	Output
5	LIMIT+	Input
6	LIMIT-	Input
7	ORIGIN	Input
8	Digital In1	Input
9	Digital In2	Input
10	Digital In3	Input
11	Digital In4	Input
12	Digital In5	Input
13	Digital In6	Input
14	Digital In7	Input
15	Compare Out	Output
16	Digital Out1	Output

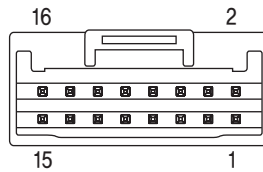

#### 5. Power Connector(CN2)

NO.	Function	I/O
1	24VDC	Input
2	GND	Input

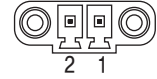

#### 6. RS-485 Communication Connector(CN3, CN4)

RS-485 Communication port to connect with Host controller

NO.	Function
1	Data+
2	Data-
3	GND

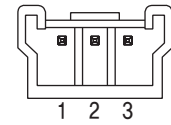

### ● System Configuration

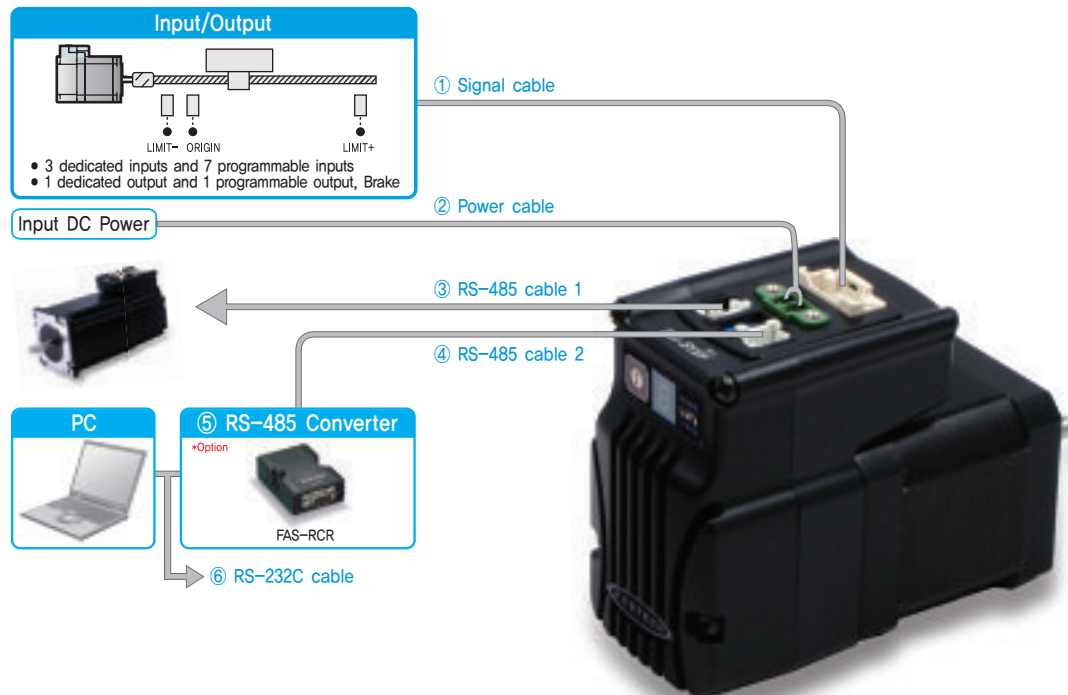

Type	Signal Cable	Power	RS-485 Cable
Length supplied	-	-	-
Max. Length	20m	2m	30m

## 1. Options

### ① Signal Cable

Available to connect between Input/Output signals and Ezi-STEP-ALL-42/56.

Item	Length [m]	Remark
CSVA-S-□□□F	□□□	Normal Cable
CSVA-S-□□□M	□□□	Robot Cable

□ is for Cable Length, The unit is 1m and Max. 20m length.

### ② Power Cable

Available to connect between Power and Ezi-STEP-ALL-42/56.

Item	Length [m]	Remark
CSVA-P-□□□F	□□□	Normal Cable
CSVA-P-□□□M	□□□	Robot Cable

□ is for Cable Length, The unit is 1m and Max. 2m length.

### ③ RS-485 Cable 1

Common cable to connect Ezi-SERVO-ALL-42/56, Ezi-STEP-ALL-42/56, Ezi-MOTIONLINK Plus-R and Ezi-SERVO Plus-R MINI thru by Network.

Item	Length [m]	Remark
CGNB-R-0R6F	0.6	Normal Cable
CGNB-R-001F	1	
CGNB-R-1R5F	1.5	
CGNB-R-002F	2	
CGNB-R-003F	3	
CGNB-R-005F	5	

### ④ RS-485 Cable 2

RCR to Ezi-SERVO-ALL-42/56, FAS-RCR to Ezi-STEP-ALL-42/56, FAS-RCR to Ezi-SERVO Plus-R MINI, FAS-RCR to Ezi-MOTIONLINK Plus-R.

Item	Length [m]	Remark
CGNA-R-0R6F	0,6	Normal Cable
CGNA-R-001F	1	
CGNA-R-1R5F	1,5	
CGNA-R-002F	2	
CGNA-R-003F	3	
CGNA-R-005F	5	

### ⑤ FAS-RCR(RS-232C to RS-485 Converter)

Item	Specification
Comm, Speed	Max. 115,2 [kbps]
Comm, Distance	RS-232C: Max. 15m RS-485: Max. 1,2km
Connection Type	RS-232C: DB9 Female RS-485: RJ-45
Dimension	50×75×23mm
Weight	38g
Power	Powered from PC (Usable for external DC5~24V)

### ⑥ RS-232C Cable

Available to connect between RS-232C port of master and FAS-RCR.

Item	Length [m]	Remark
CGNR-C-002F	2	Normal Cable
CGNR-C-003F	3	
CGNR-C-005F	5	

## 2. Connector Specifications

Connector specifications for cabling to drive.

Purpose	Item	Part Number	Manufacturer
Signal (CN1)	Housing Terminal	501646-1600 501648-1000 (AWG 26~28)	MOLEX
Power (CN2)	Terminal Block	MC421-38102	DECA
RS-485 Communication (CN3, CN4)	Housing Terminal	35507-0300 50212-8100	MOLEX

※ Above connector is the most suitable product for the drive applied. Another equivalent connector can be used.

# External Wiring Diagram

FASTECH Ezi-STEP ALL

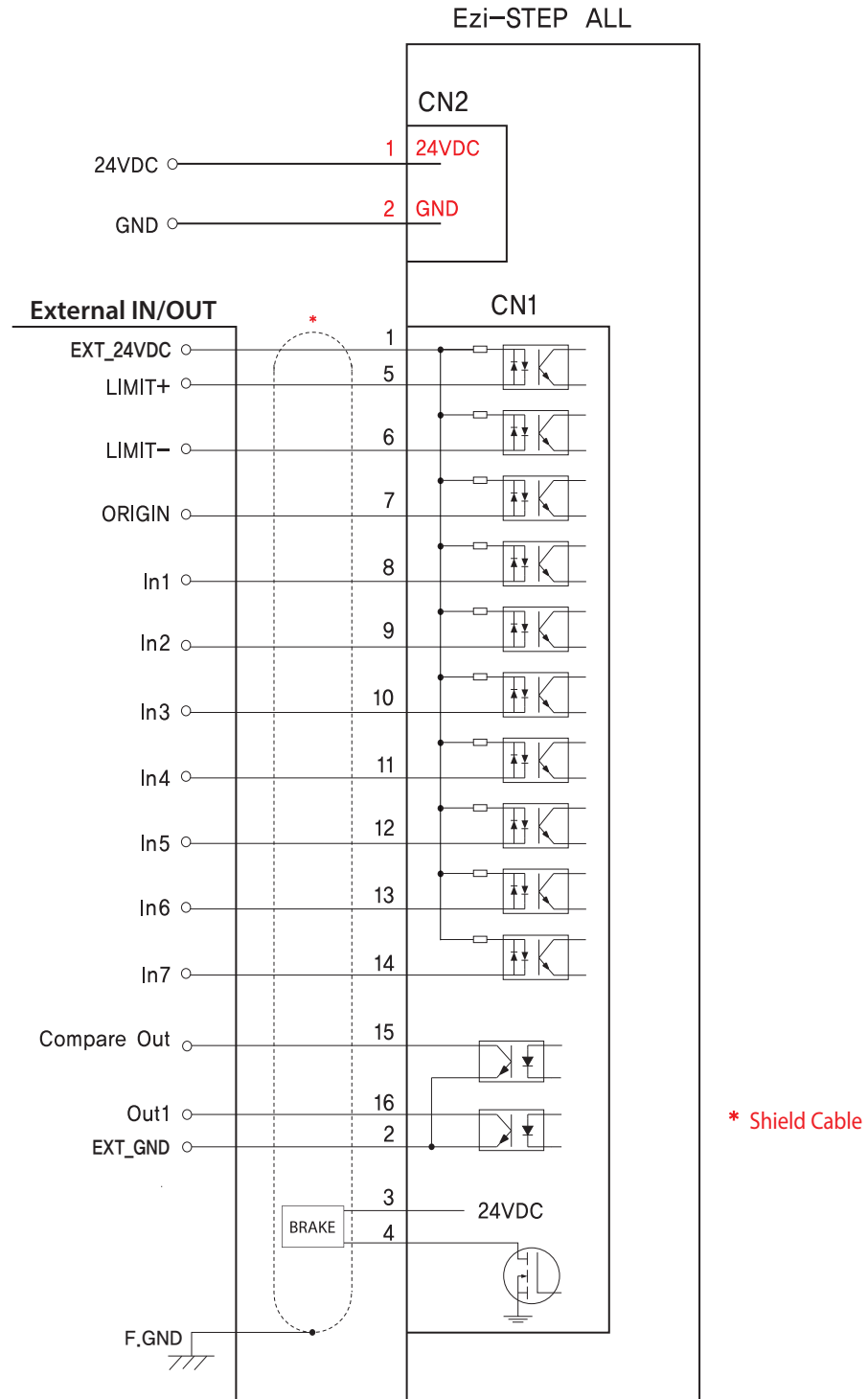

※ When connects I/O cable between controller and drive, please turn off the power of both controller and drive, in order to protect the drive from any damage.

## ● GUI(Graphic User Interface) Screenshot



### ◆ Controller Lists and Motion Test

This screen displays the controller list that connected to system. You can make a single move, jog and origin command and also the motor status is displayed.



### ◆ Parameter List

All of the parameters are displayed and modified on this screen.



### ◆ Motion Repeat and Monitor Status

Target position, speed, delay time and repeat count are selected for repeat motion test. Motion library(DLL) is also displayed on screen.



### ◆ I/O Monitoring and Setting

You can select various digital input and output signals of controller.



### ◆ Position Table

You can edit the position table and execute it. The position table data can be saved and loaded from Flash ROM and Windows file.

- ※ Graphic User Interface(GUI) Program can be downloaded from website, ([www.fastech.co.kr](http://www.fastech.co.kr))
- ※ Graphic User Interface(GUI) Program can support Windows 7/8/10.
- ※ Graphic User Interface(GUI) Program can be update without prior notice for improving the performance or convenience of user.



*Fast, Accurate, Smooth Motion*

**FASTECH Co., Ltd.**

Rm#1202, 401-dong, Bucheon Techno-Park,  
655, Pyeongcheon-ro, Bucheon-si Gyeonggi-do,  
Republic of Korea (Zip:14502)  
TEL : +82-32-234-6300 FAX : +82-32-234-6302  
E-mail : sales2@fastech.co.kr  
Homepage : www.fastech.co.kr