

Ezi-STEP[®]

Micro Stepping System

- Micro Stepping
- Software Damping
- Run/Stop Signal Output

ST

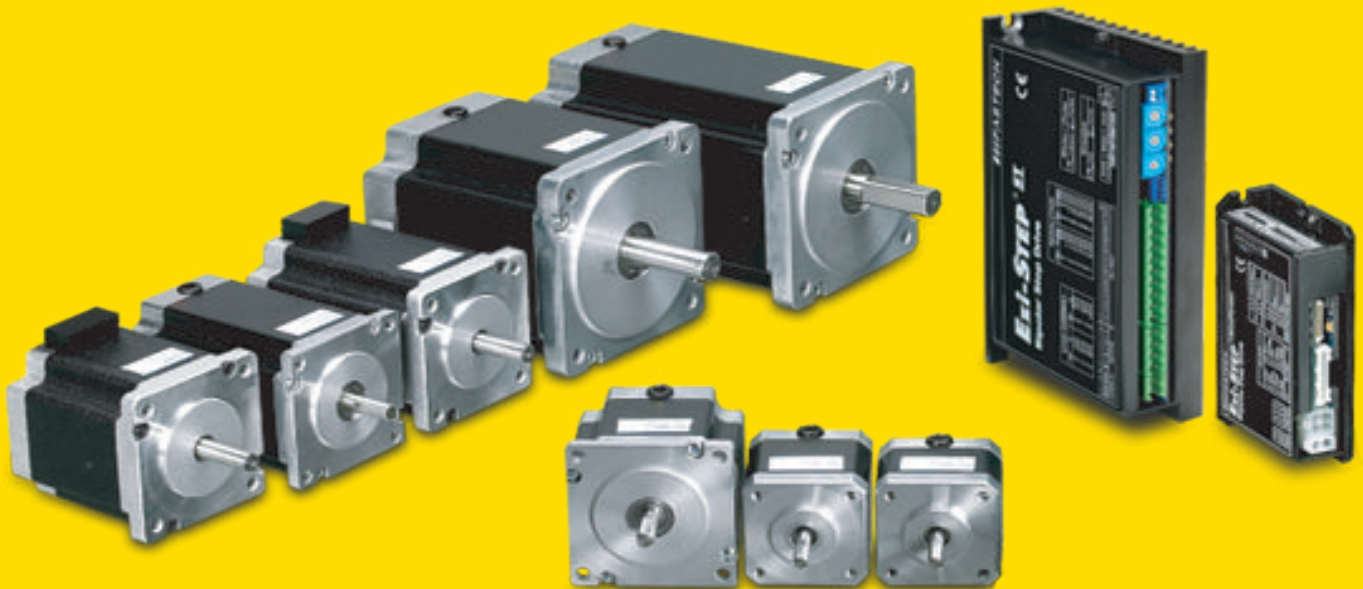

CE

FASTECH

Fast, Accurate, Smooth Motion

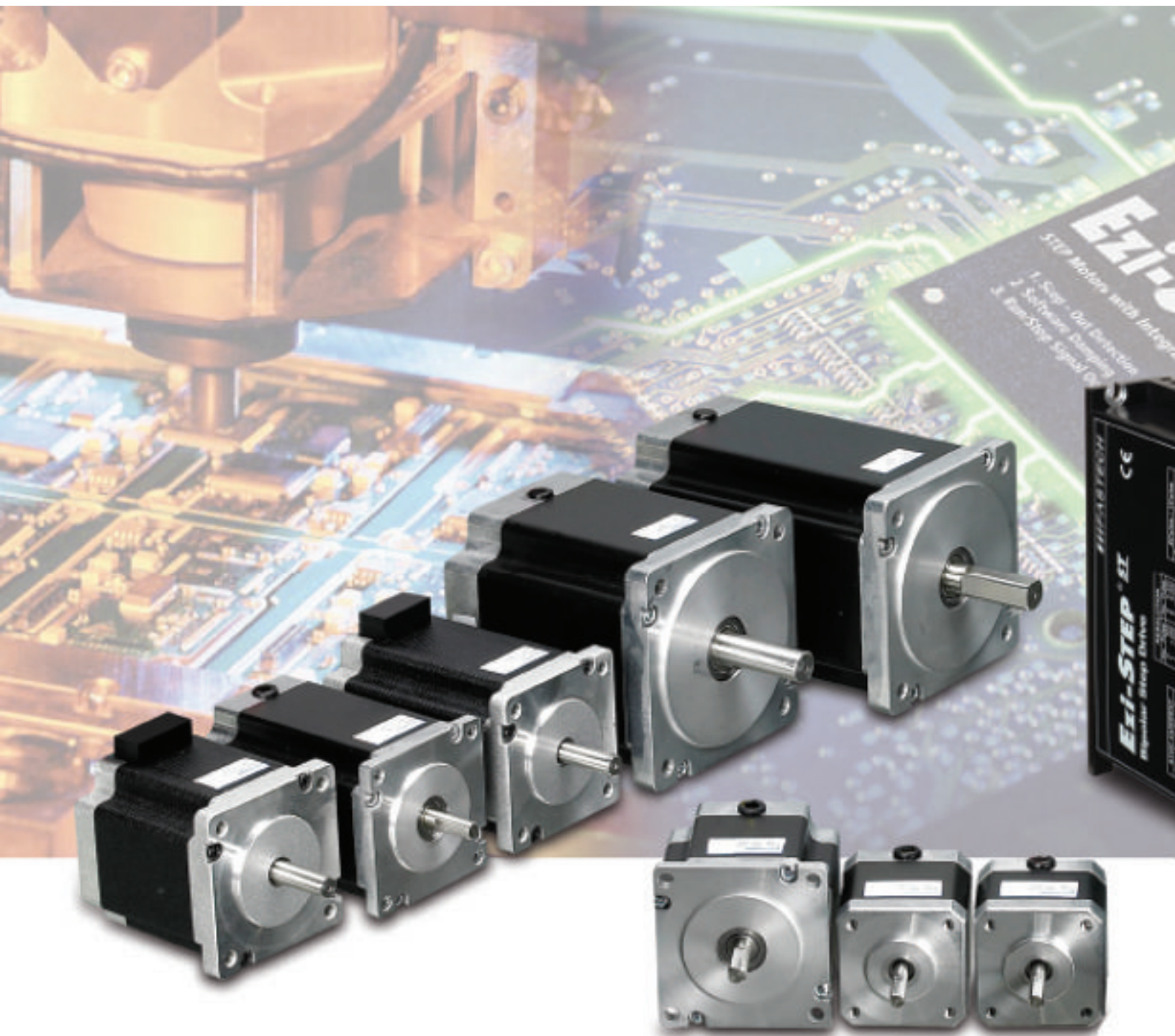

Fast, Accurate, Smooth Motion

Ezi-STEP[®] ST
Micro Stepping System



● Ezi-STEP Characteristics

Ezi-STEP ST is a micro stepping system that incorporates a motor and MCU (Micro Controller Unit) equipped drive that is integrated seamlessly together as a system. This makes it possible to incorporate many functions compared with a conventional stepping motors and drives, such as sensorless detection of loss of synchronization, smooth control over the whole velocity range, higher torque operation and no vibration at the low speed range.

Ezi-STEP ST's on-board high-performance digital signal processor and proprietary algorithms allow the Ezi-STEP ST to operate at high speeds with unmatched precision. The unique position estimation algorithm instantaneously detects out-of-synchronization based on the rotor position of the stepping motor, which is not an easy task in a conventional stepping motor and drives.

Utilizing a software damping and filtering algorithms, high speed operation is realized by the exciting angle control of a step-angle. The resolution of Ezi-STEP ST can be selected from basic 1.8° up to 0.0072° (1/250). In addition, Ezi-STEP ST generates various signals including sensorless stall detection, alarm and running signal. Ezi-STEP ST is an economical ideal drive for vision systems, nanotech, packaging, semiconductor, pick and place, automation, laboratory testing, wood working and wherever smooth, quiet, precise, high torque operation is a requirement.

1 Microstep and Filtering

High precision Microstep function and Filtering

The high-performance MCU operates at step resolutions of 1.8° up to maximum 0.0072° (1/250 steps) and Ezi-STEP adjusts PWM control signal in every $25 \mu\text{sec}$, which makes it possible for more precise current control, resulting in high-precision Microstep operation.

2 Software Damping

Vibration suppression and high-speed operation

Vibration suppression and High-speed operation (Patent pending) Motor vibration is created by magnetic flux variations of the motor, lower current from the drive due to back-emf from the motor at high speeds and lowering of phase voltages from the drive.

Ezi-STEP drive detects these problems and the MCU adjusts the phase of the current according to the pole position of the motor, drastically suppressing vibration. This allows the smooth operation of the motor at high speeds.

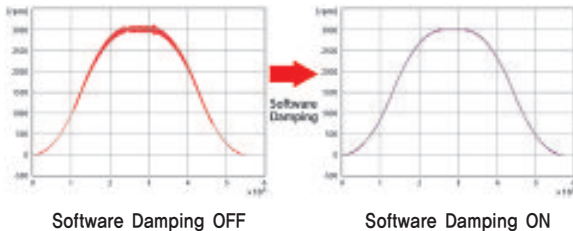

※ This is real measured speed that using 100,000 [pulse/rev] encoder.

3 Drive Output Signal Monitoring

Ezi-STEP provides loss of step, run/stop, over-current, over-heat, over-voltage, power and motor connection alarms that can be monitored by the controller and visible by a motor-mounted flashing LED indicator.

4 Improvement of High-Speed Driving

Depending on the speed of a stepping motor, Ezi-STEP automatically increases the supply voltage and prevents the torque lowering due to the low operating voltage to the motor caused by back-emf voltage, this enables high-speed operation. Additionally, the software damping algorithm minimizes the vibration and prevents the loss-of-synchronization at high-speed.

Applicable model : Ezi-STEP-MPB-42 Series
Ezi-STEP-MPB-56 Series
Ezi-STEP-MPB-60 Series
Ezi-STEP-HPB-86 Series

● Ezi-STEP ST Part Numbering

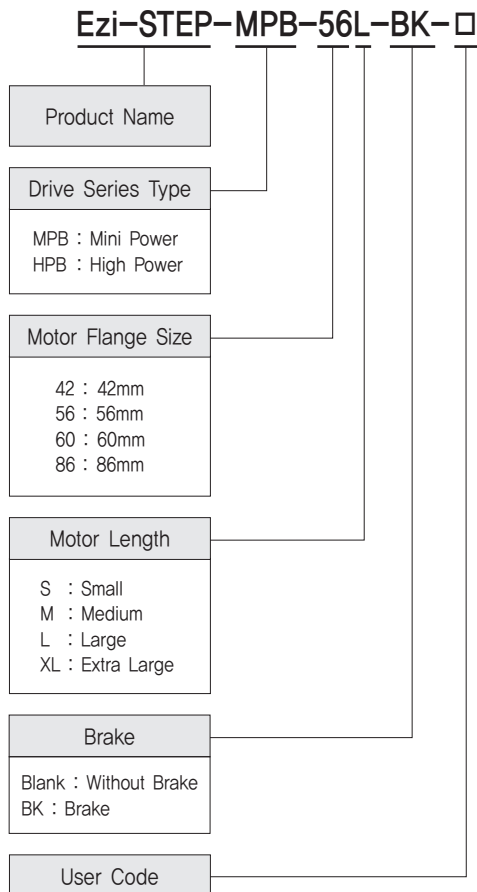

● Standard Combination

Unit Part Number	Motor Model Number	Drive Model Number
Ezi-STEP-MPB-42S	BM-42S	EzStep-MPB-42S
Ezi-STEP-MPB-42M	BM-42M	EzStep-MPB-42M
Ezi-STEP-MPB-42L	BM-42L	EzStep-MPB-42L
Ezi-STEP-MPB-42XL	BM-42XL	EzStep-MPB-42XL
Ezi-STEP-MPB-56S	BM-56S	EzStep-MPB-56S
Ezi-STEP-MPB-56M	BM-56M	EzStep-MPB-56M
Ezi-STEP-MPB-56L	BM-56L	EzStep-MPB-56L
Ezi-STEP-MPB-60S	BM-60S	EzStep-MPB-60S
Ezi-STEP-MPB-60M	BM-60M	EzStep-MPB-60M
Ezi-STEP-MPB-60L	BM-60L	EzStep-MPB-60L
Ezi-STEP-HPB-86M	BM-86M	EzStep-HPB-86M
Ezi-STEP-HPB-86L	BM-86L	EzStep-HPB-86L
Ezi-STEP-HPB-86XL	BM-86XL	EzStep-HPB-86XL

● Combination with Brake

Unit Part Number	Motor Model Number	Drive Model Number
Ezi-STEP-MPB-42S-BK	BM-42S-BK	EzStep-MPB-42S
Ezi-STEP-MPB-42M-BK	BM-42M-BK	EzStep-MPB-42M
Ezi-STEP-MPB-42L-BK	BM-42L-BK	EzStep-MPB-42L
Ezi-STEP-MPB-42XL-BK	BM-42XL-BK	EzStep-MPB-42XL
Ezi-STEP-MPB-56S-BK	BM-56S-BK	EzStep-MPB-56S
Ezi-STEP-MPB-56M-BK	BM-56M-BK	EzStep-MPB-56M
Ezi-STEP-MPB-56L-BK	BM-56L-BK	EzStep-MPB-56L
Ezi-STEP-MPB-60S-BK	BM-60S-BK	EzStep-MPB-60S
Ezi-STEP-MPB-60M-BK	BM-60M-BK	EzStep-MPB-60M
Ezi-STEP-MPB-60L-BK	BM-60L-BK	EzStep-MPB-60L
Ezi-STEP-HPB-86M-BK	BM-86M-BK	EzStep-HPB-86M
Ezi-STEP-HPB-86L-BK	BM-86L-BK	EzStep-HPB-86L
Ezi-STEP-HPB-86XL-BK	BM-86XL-BK	EzStep-HPB-86XL

● Specifications of Drive

Motor Model	BM-42 series	BM-56 series	BM-60 series	BM-86 series
Driver Model	EzStep-MPB-42 series	EzStep-MPB-56 series	EzStep-MPB-60 series	EzStep-HPB-86 series
Input Voltage	24VDC \pm 10%			40~70VDC
Control Method	Bipolar PWM drive with 32bit MCU			
Current Consumption	Max 500mA (Except motor current)			
Operating Condition	Ambient Temperature	<ul style="list-style-type: none"> · In Use: 0~50°C · In Storage: -20~70°C 		
	Humidity	<ul style="list-style-type: none"> · In Use: 35~85% RH (Non-Condensing) · In Storage: 10~90% RH (Non-Condensing) 		
	Vib. Resist.	0,5g		
Function	Rotation Speed	0~3,000 [rpm] *1		
	Resolution [ppr]	500 1,000 1,600 2,000 3,200 3,600 4,000 5,000 6,400 8,000 10,000 20,000 25,000 36,000 40,000 50,000 (Selectable with DIP Switch) * Default: 10,000		
	Maximum Frequency	500kHz (Duty 50%)		
	Protection Functions	Over Current Error, Over Speed Error, Step Out Error, Over Temperature Error, Over Regenerated Voltage Error, Motor Connect Error, Motor Voltage Error, System Error, ROM Error		
	LED Display	Power Status(Green), Alarm Status(Red), CW Rotation(Yellow), CCW Rotation(Orange)		
	STOP Current	10%~100% (Selectable with DIP Switch) Be setted to set value of STOP Current after 0,1 second after motor stop. * Default: 50%		
	Pulse Input Method	1 Pulse / 2 Pulse (Selectable with DIP Switch) 1 Pulse: Pulse/Direction, 2 Pulse: CW/CCW * Default: 2 Pulse		
	Rotational Direction	CW/CCW (Selectable with DIP Switch) Used when changing the direction of motor rotate. * Default: CW		
	Speed/Position Control Command	Pulse Train Input (Photocoupler Input)		
I/O Signal	Input Signals	Motor Free / Alarm Reset (Photocoupler Input)		
	Output Signals	Alarm, Run/Stop (Photocoupler Output)		

*1 : Up to the resolution of 10,000[ppr], maximum speed can be reached by 3,000[rpm] and with the resolution more than 10,000[ppr], maximum speed shall be reduced accordingly.

● Dimensions of Drive [mm]

◆ Ezi-STEP-MPB Drive

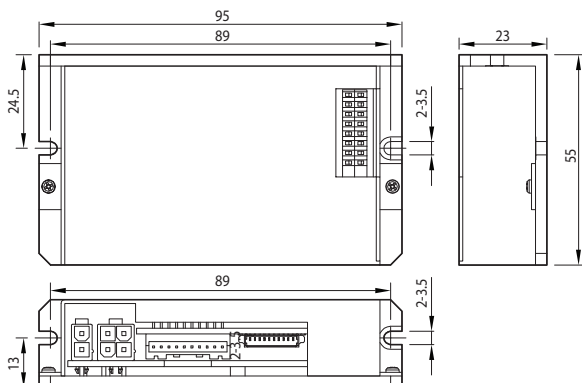

◆ Ezi-STEP-HPB Drive

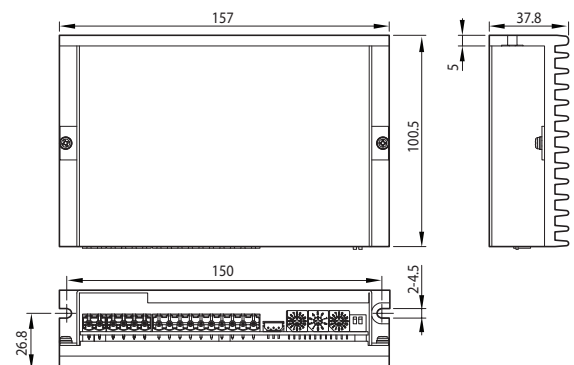

● Specifications of Motor

MODEL		UNIT	BM-42 series				BM-56 series			
			42S	42M	42L	42XL	56S	56M	56L	
DRIVE METHOD		–	BI-POLAR							
NUMBER OF PHASES		–	2	2	2	2	2	2	2	
CURRENT per PHASE		A	1,2	1,2	1,2	1,2	3,0	3,0	3,0	
HOLDING TORQUE		N·m	0,32	0,44	0,5	0,65	0,64	1,0	1,5	
ROTOR INERTIA		g·cm ²	35	54	77	114	180	280	520	
WEIGHTS		g	238	303	374	508	548	726	1159	
LENGTH(L)		mm	34	40	48	60	46	55	80	
PERMISSIBLE OVERHUNG LOAD (DISTANCE FROM END OF SHAFT)	3mm	N	22	22	22	22	52	52	52	
	8mm		26	26	26	26	65	65	65	
	13mm		33	33	33	33	85	85	85	
	18mm		46	46	46	46	123	123	123	
PERMISSIBLE THRUST LOAD		N	Lower than motor weight							
INSULATION RESISTANCE		Mohm	100 MIN.(at 500VDC)							
INSULATION CLASS		–	CLASS B(130°C)							
OPERATING TEMPERATURE		°C	0 to 55							

MODEL		UNIT	BM-60 series			BM-86 series			
			60S	60M	60L	86M	86L	86XL	
DRIVE METHOD		–	BI-POLAR						
NUMBER OF PHASES		–	2	2	2	2	2	2	
CURRENT per PHASE		A	4,0	4,0	4,0	6,0	6,0	6,0	
HOLDING TORQUE		N·m	0,88	1,28	2,4	4,5	8,5	12	
ROTOR INERTIA		g·cm ²	240	490	690	1800	3600	5400	
WEIGHTS		g	616	793	1349	2275	3808	5330	
LENGTH(L)		mm	47	56	85	78	117	155	
PERMISSIBLE OVERHUNG LOAD (DISTANCE FROM END OF SHAFT)	3mm	N	70	70	70	270	270	270	
	8mm		87	87	87	300	300	300	
	13mm		114	114	114	350	350	350	
	18mm		165	165	165	400	400	400	
PERMISSIBLE THRUST LOAD		N	Lower than motor weight						
INSULATION RESISTANCE		Mohm	100 MIN.(at 500VDC)						
INSULATION CLASS		–	CLASS B(130°C)						
OPERATING TEMPERATURE		°C	0 to 55						

Torque Characteristics of Motor

Ezi-STEP-MPB-42 series

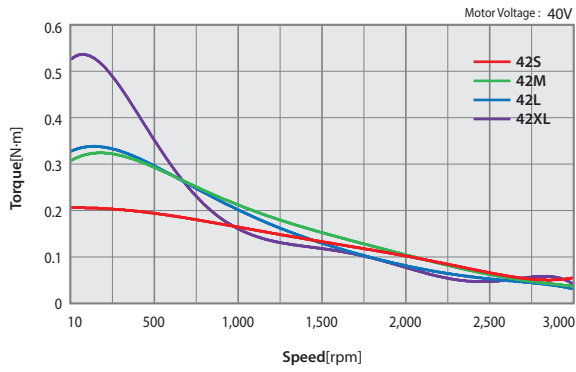

Ezi-STEP-MPB-56 series

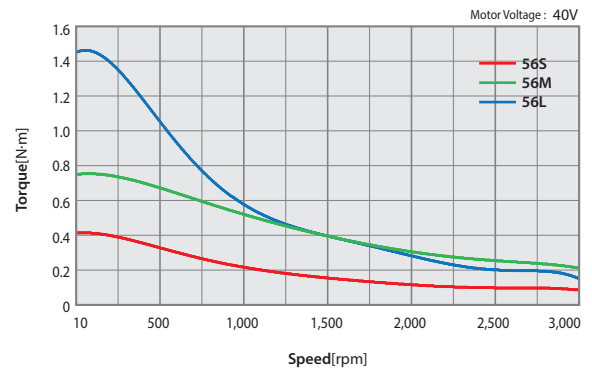

Ezi-STEP-MPB-60 series

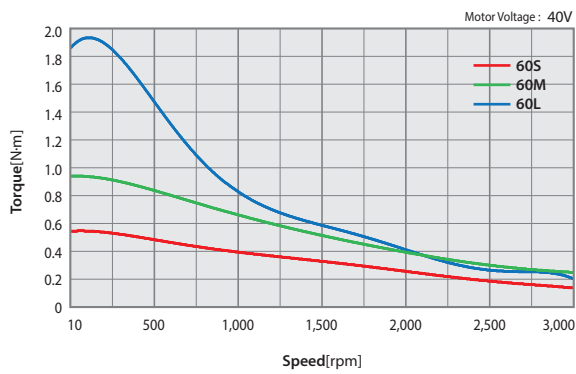

Ezi-STEP-HPB-86 series

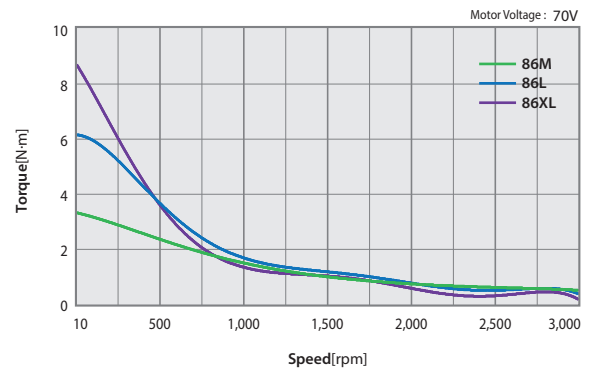

● Dimensions of Motor [mm]

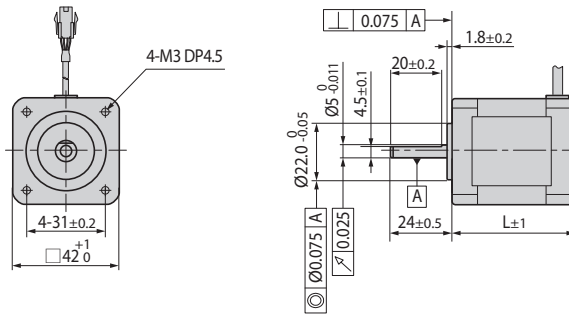

42mm

Model name	Length(L)
BM-42S	34
BM-42M	40
BM-42L	48
BM-42XL	60

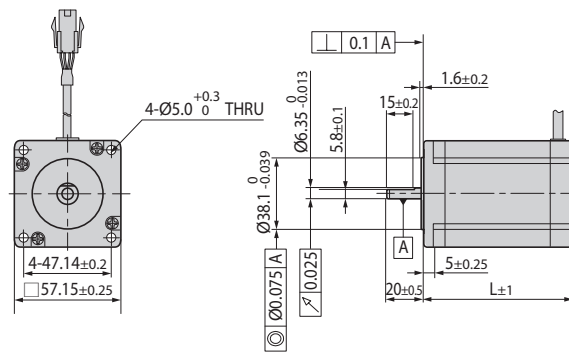

56mm

Model name	Length(L)
BM-56S	46
BM-56M	55
BM-56L	80

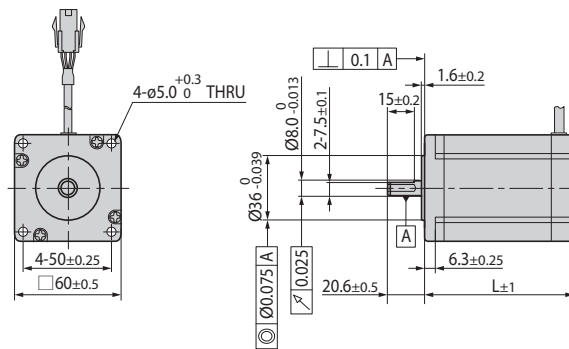

60mm

Model name	Length(L)
BM-60S	47
BM-60M	56
BM-60L	85

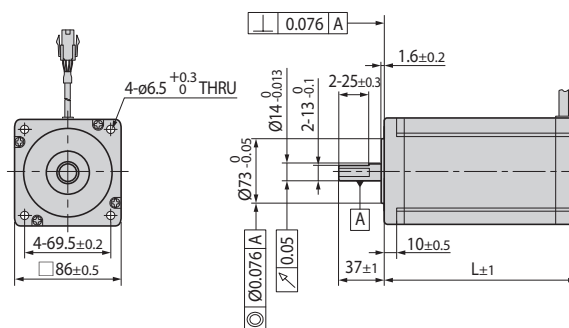

86mm

Model name	Length(L)
BM-86M	78
BM-86L	117
BM-86XL	155

● Specifications of Motor with Brake

Unit Part Number	Motor Model Number	Electronic Brake					Motor Unit Weight [g]	Permitted Overhung Load [N]				Permitted Thrust Load [N]
		Type	Voltage Input [V]	Rated Current [A]	Power Consumption [W]	Statical Friction Torque [N·m]		Length from Motor Point [mm]				
								3	8	13	18	
Ezi-STEP-MPB-42S-BK	BM-42S-BK	Non-excitation run Type	24VDC ±10%	0.2	5	0.2	500	22	26	33	46	Must be Lower than Unit's Weight
Ezi-STEP-MPB-42M-BK	BM-42M-BK						560					
Ezi-STEP-MPB-42L-BK	BM-42L-BK						630					
Ezi-STEP-MPB-42XL-BK	BM-42XL-BK						770					
Ezi-STEP-MPB-56S-BK	BM-56S-BK			970	52	65	85	123				
Ezi-STEP-MPB-56M-BK	BM-56M-BK			1150								
Ezi-STEP-MPB-56L-BK	BM-56L-BK			1580								
Ezi-STEP-MPB-60S-BK	BM-60S-BK			1060	70	87	114	165				
Ezi-STEP-MPB-60M-BK	BM-60M-BK			1230								
Ezi-STEP-MPB-60L-BK	BM-60L-BK			1790								
Ezi-STEP-HPB-86M-BK	BM-86M-BK			3580	270	300	350	400				
Ezi-STEP-HPB-86L-BK	BM-86L-BK			5110								
Ezi-STEP-HPB-86XL-BK	BM-86XL-BK	6630										

- * Electronic Brake cannot be used for braking. Position hold purpose only when power OFF.
- * The weight means Motor Unit Weight including Motor and Electronic Brake.
- * Motor Model Number is combined model name of Motor and Brake.
- * Motor specification and torque characteristic are same as Standard Motor.

* Brake Operation Timing Chart

Ezi-STEP MPB/HPB has no brake control function.

Brake must be controlled by the host controller. Please refer to below Timing Chart when control Brake from upper controller. Otherwise, Drive malfunctioning and loads can be fall down.

Also, please do not operate Brake while motor operation to prevent damage.

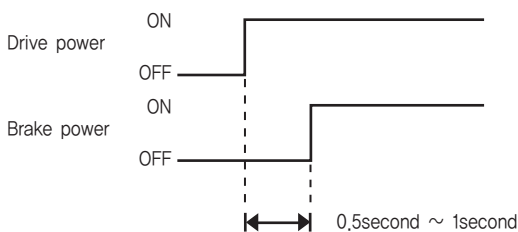

● Dimensions of Motor with Brake [mm]

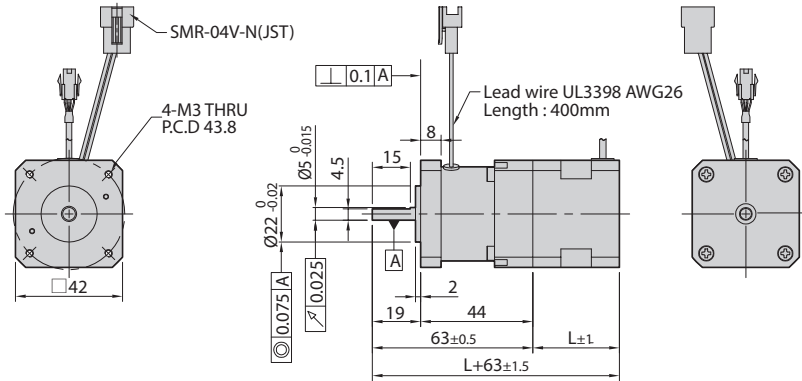

42mm

Model Name	Length(L)	Weight(kg)
BM-42S	34	0.50
BM-42M	40	0.56
BM-42L	48	0.63
BM-42XL	60	0.77

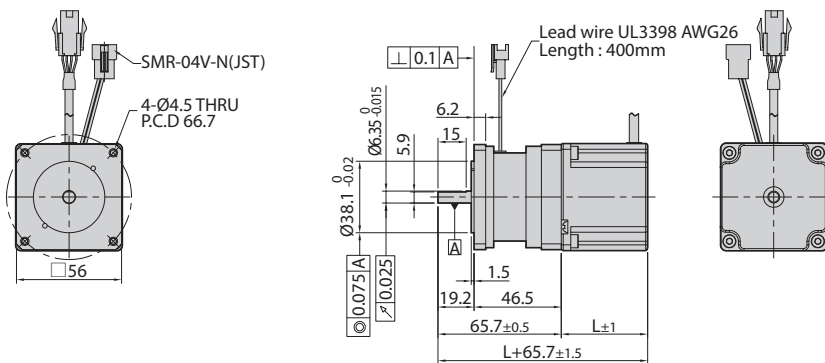

56mm

Model Name	Length(L)	Weight(kg)
BM-56S	46	0.97
BM-56M	55	1.15
BM-56L	80	1.58

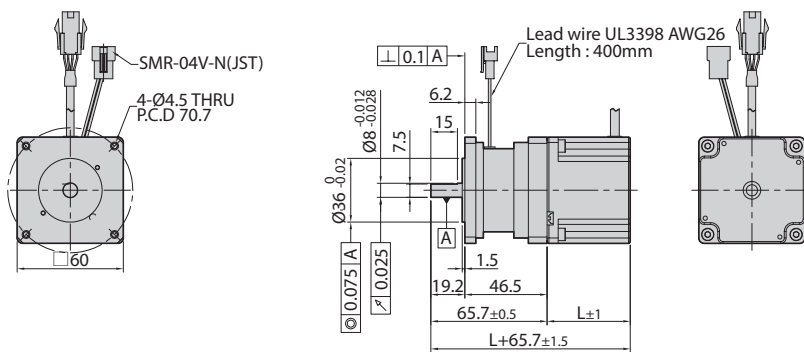

60mm

Model Name	Length(L)	Weight(kg)
BM-60S	47	1.06
BM-60M	56	1.23
BM-60L	85	1.79

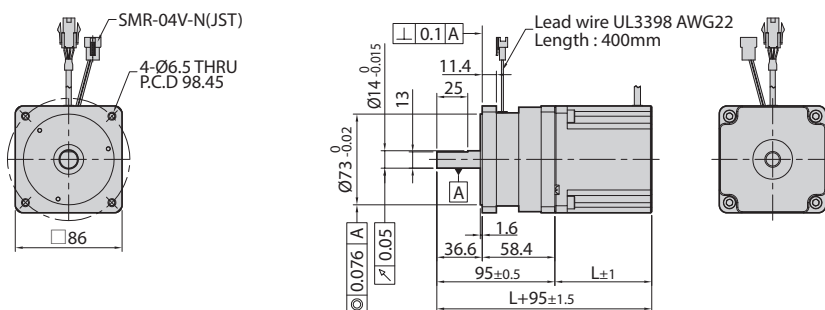

86mm

Model Name	Length(L)	Weight(kg)
BM-86M	78	3.58
BM-86L	117	5.11
BM-86XL	155	6.63

● Settings and Operation [Ezi-STEP-MPB series]

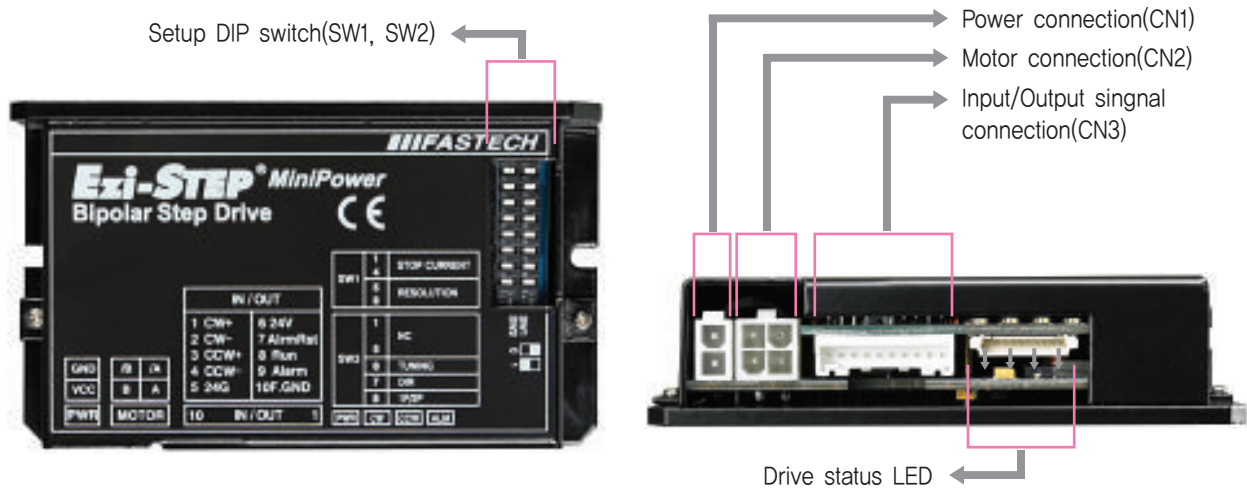

1. Drive Status LED

Indication	Color	Function	ON/OFF Condition
PWR	Green	Power input indication	Lights when power is ON Flashes when motor is Free status
ALM	Red	Alarm indication	Flash when protection function is activated (Identifiable which protection mode is activated by counting the blinking times)
CW	Yellow	Motor Rotation Direction	Lights when motor rotate CW direction
CCW	Orange	Motor Rotation Direction	Lights when motor rotate CCW direction

◆ Protection functions and LED flash times

Times	Protection	Conditions
1	Over Current Error	The current through power devices in drive exceeds the limit value*
2	Over Speed Error	Motor speed exceeded 3,000 [rpm]
3	Step Out Error	Abnormally motor do not followed pulsed input
5	Over Temperature Error	Internal temperature of a motor drive exceeded 85°C
6	Over Regenerative Voltage Error	Back EMF more than 70V
7	Motor Connect Error	Power is ON without connection of motor cable to drive
9	Motor Voltage Error	Motor voltage is below 36V
11	System Error	Error occurs in drive system
12	ROM Error	Error occurs in Parameter storage Device(ROM)

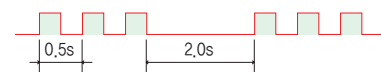

Alarm LED flash
(Ex, Step Out Error)

*1 : Limit value depends on motor model (Refer to the Manual)

2. Stop Current Setting Switch(SW1.1~SW1.4)

Stop Current means the motor current value automatically set in 0.1 sec after motor stops. This is to prevent the overheart of a motor when the motor is under long time idling. The un itof the selection value is a percentage,

Switch Position				STOP Current (%)	Switch Position				STOP Current (%)
4	3	2	1		4	3	2	1	
ON	ON	ON	ON	10	OFF	ON	ON	ON	90
ON	ON	ON	OFF	20	OFF	ON	ON	OFF	100
ON	ON	OFF	ON	30	OFF	ON	OFF	ON	10
ON	ON	OFF	OFF	40	OFF	ON	OFF	OFF	10
ON	OFF	ON	ON	50*	OFF	OFF	ON	ON	10
ON	OFF	ON	OFF	60	OFF	OFF	ON	OFF	10
ON	OFF	OFF	ON	70	OFF	OFF	OFF	ON	10
ON	OFF	OFF	OFF	80	OFF	OFF	OFF	OFF	10

*1 : Default : 50%

3. Resolution Setting Switch(SW1,5~1.8)

The Number of pulse per revolution.

Switch Position				Pulse/ Revolution	Switch Position				Pulse/ Revolution
8	7	6	5		8	7	6	5	
ON	ON	ON	ON	500	OFF	ON	ON	ON	6,400
ON	ON	ON	OFF	1,000	OFF	ON	ON	OFF	8,000
ON	ON	OFF	ON	1,600	OFF	ON	OFF	ON	10,000*
ON	ON	OFF	OFF	2,000	OFF	ON	OFF	OFF	20,000
ON	OFF	ON	ON	3,200	OFF	OFF	ON	ON	25,000
ON	OFF	ON	OFF	3,600	OFF	OFF	ON	OFF	36,000
ON	OFF	OFF	ON	4,000	OFF	OFF	OFF	ON	40,000
ON	OFF	OFF	OFF	5,000	OFF	OFF	OFF	OFF	50,000

*1 : Default : 10,000

4. Rotational Direction Setting Switch(SW2,7)

Indication	Switch Name	Functions
DIR	Rotational Direction Select Switch	Based on CW(+Dir signal) input to driver. ON: CCW(-Direction) OFF: CW(+Direction) ※ Default: CW mode



5. Pulse Input Setting Switch(SW2,8)

Indication	Switch Name	Functions
1P/2P	Pulse input mode Select Switch	Selectable 1-Pulse input mode or 2-Pulse input mode as Pulse input signal. ON: 1-Pulse mode OFF: 2-Pulse mode ※ Default: 2-Pulse mode

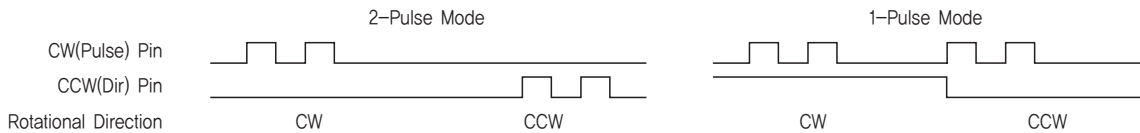

6. Power Connector(CN1)

NO.	Function	I/O
1	24VDC	Input
2	GND	Input

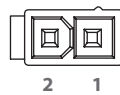

7. Motor Connector(CN2)

NO.	Function	I/O
1	A Phase	Output
2	B Phase	Output
3	/A Phase	Output
4	/B Phase	Output

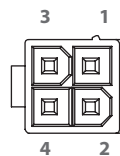

8. Signal Connector(CN3)

NO.	Function	I/O
1	CW+(Pulse+)	Input
2	CW-(Pulse-)	Input
3	CCW+(Dir+)	Input
4	CCW-(Dir-)	Input
5	EXT_GND	Input
6	EXT_24VDC	Input
7	Alarm Reset	Input
8	Run/Stop	Output
9	Alarm	Output
10	F_GND	----

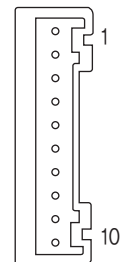

● System Configuration [Ezi-STEP-MPB series]

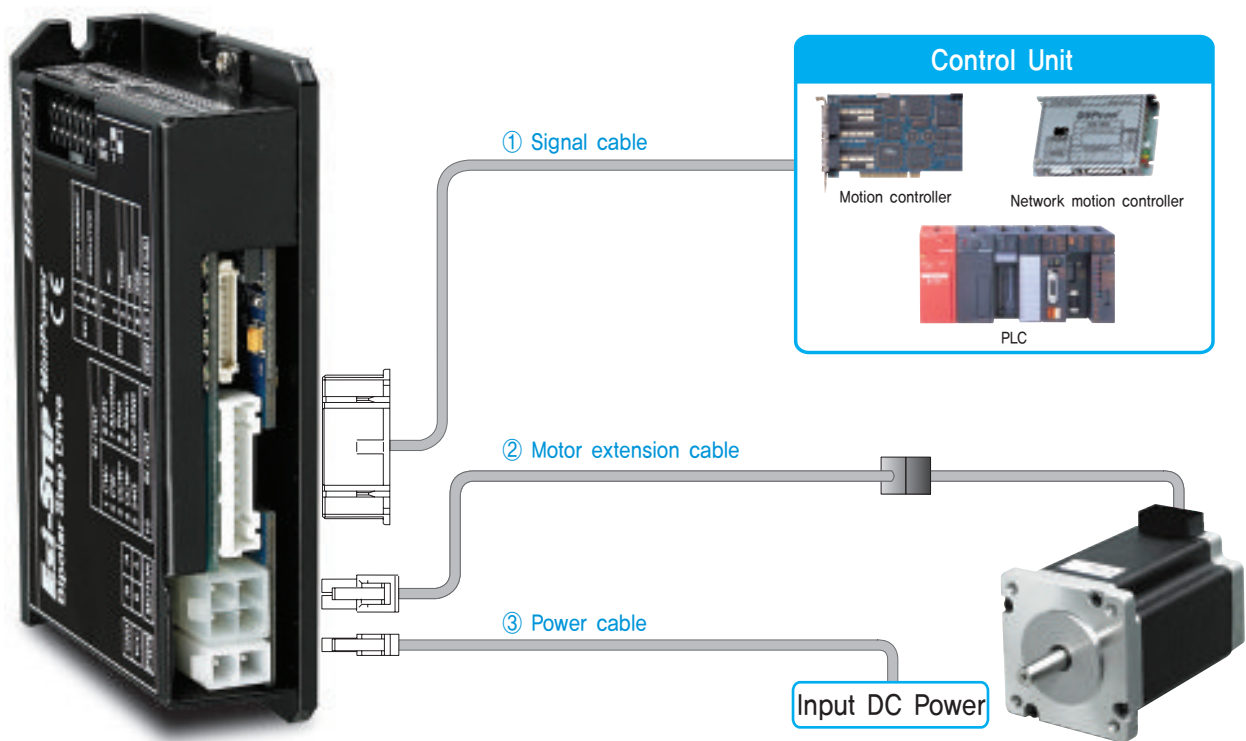

Type	Signal Cable	Motor Cable	Power Cable
Length supplied	-	30cm	-
Max. Length	20m	20m	2m

FASTECH Ezi-STEP ST

1. Options

① Signal Cable

Available to connect between Input/Output Control System and Ezi-STEP MPB.

Item	Length [m]	Remark
CMNB-S-□□□F	□□□	Normal Cable
CMNB-S-□□□M	□□□	Robot Cable

□ is for Cable Length. The unit is 1m and Max. 20m length.

③ Power Cable

Available to connect between Power and Ezi-STEP MPB.

Item	Length [m]	Remark
CSVO-P-□□□F	□□□	Normal Cable
CSVO-P-□□□M	□□□	Robot Cable

□ is for Cable Length. The unit is 1m and Max. 2m length.

② Motor Extension Cable

Available to extended connection between motor and Ezi-STEP MPB.

Item	Length [m]	Remark
CSVO-M-□□□F	□□□	Normal Cable
CSVO-M-□□□M	□□□	Robot Cable

□ is for Cable Length. The unit is 1m and Max. 20m length.

2. Connector Specifications

Connector specifications for cabling to drive.

Purpose		Item	Part Number	Manufacturer
Power (CN1)		Housing Terminal	5557-02R 5556T	MOLEX
Motor	Drive side (CN2)	Housing Terminal	5557-04R 5556T	MOLEX
	Motor side	Housing Terminal	5557-04R 5556T	
Signal (CN3)		Housing Terminal	PAP-10V-S SPHD-002T-P0.5	JST

※ Above connector is the most suitable product for the drive applied. Another equivalent connector can be used.

External Wiring Diagram [Ezi-STEP-MPB series]

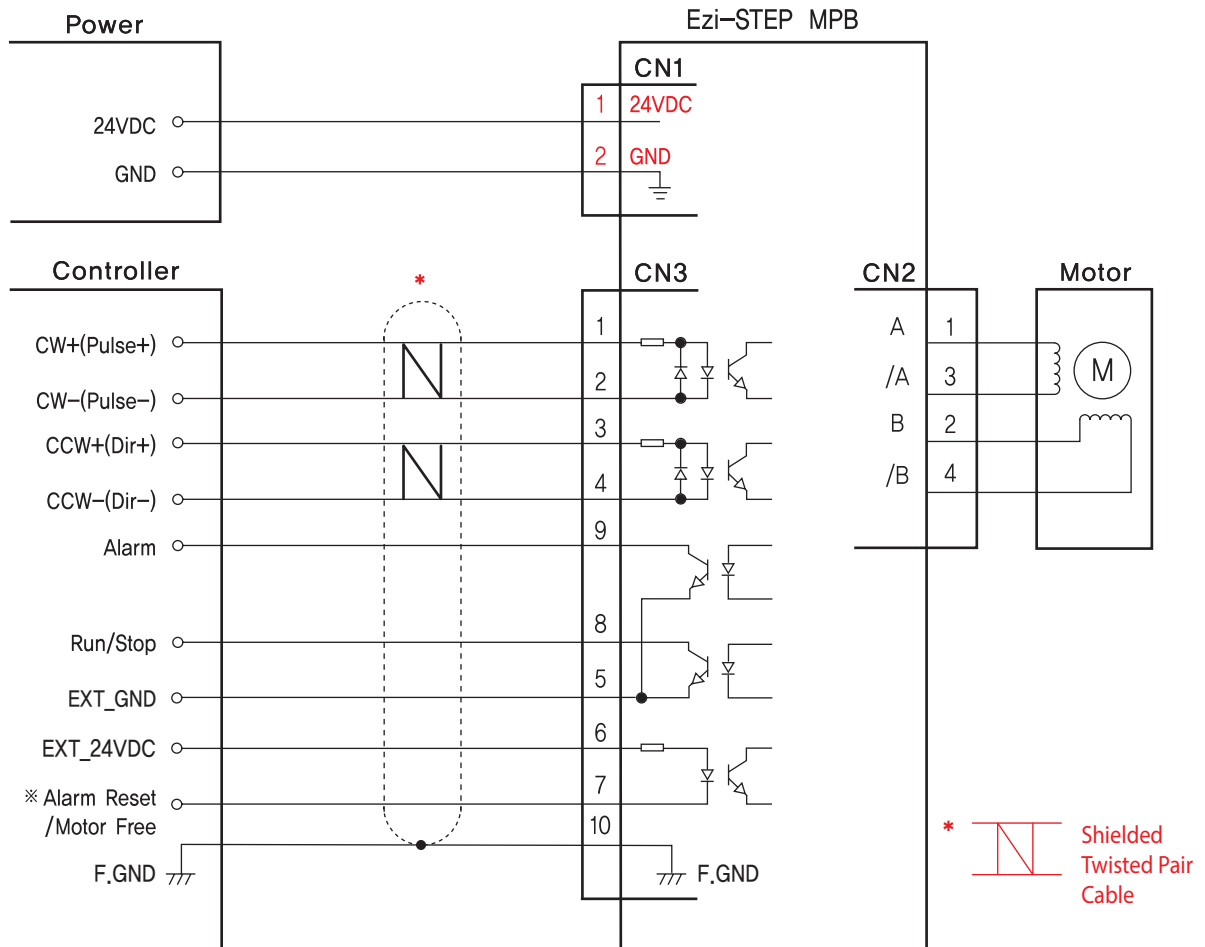

- ※ Alarm Reset signal line is also used for Motor Free signal.
(For details, please refer to Control Signal Input/Output Description)
- ※ When connects I/O cable between controller and drive, please turn off the power of both controller and drive, in order to protect the drive from any damage.

CAUTION

Please refer to the Manual when connects motor extension cable.
Careful connection will be required to protect the drive from any damages.

● Settings and Operation [Ezi-STEP-HPB series]

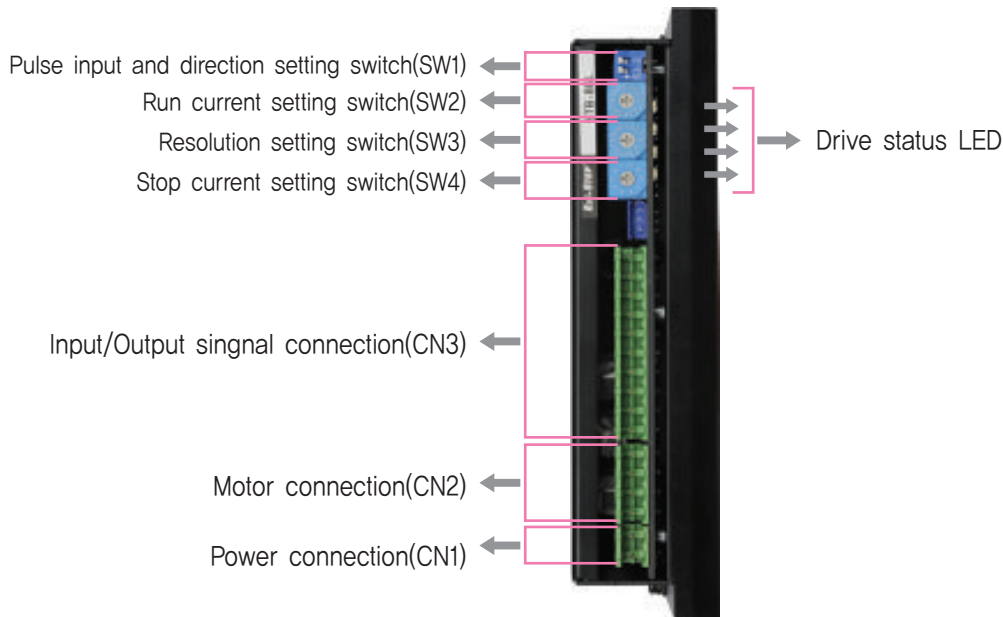

1. Drive Status LED

Indication	Color	Function	ON/OFF Condition
POW	Green	Power input indication	Lights when power is ON Flashes when motor is Free status
ALM	Red	Alarm indication	Flash when protection function is activated (Identifiable which protection mode is activated by counting the blinking times)
CW	Yellow	Motor Rotation Direction	Lights when motor rotate CW direction
CCW	Orange	Motor Rotation Direction	Lights when motor rotate CCW direction

◆ Protection functions and LED flash times

Times	Protection	Conditions
1	Over Current Error	The current through power devices in drive exceeds the limit value ^{*1}
2	Over Speed Error	Motor speed exceeded 3,000 [rpm]
3	Step Out Error	Abnormally motor do not followed pulsed input
5	Over Temperature Error	Internal temperature of a motor drive exceeded 85°C
6	Over Regenerative Voltage Error	Back EMF more than 90V
7	Motor Connect Error	Power is ON without connection of motor cable to drive
9	Motor Voltage Error	Motor voltage is below 36V
11	System Error	Error occurs in drive system
12	ROM Error	Error occurs in Parameter storage Device(ROM)

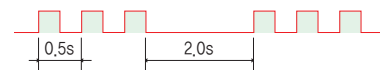

Alarm LED flash
(Ex, Step Out Error)

*1 : Limit value depends on motor model (Refer to the Manual)

2. Pulse Input Setting Switch(SW1.1)

Indication	Switch Name	Functions
2P/1P	Pulse input mode Select Switch	Selectable 1-Pulse input mode or 2-Pulse input mode as Pulse input signal. ON: 1-Pulse mode OFF: 2-Pulse mode ※ Default: 2-Pulse mode

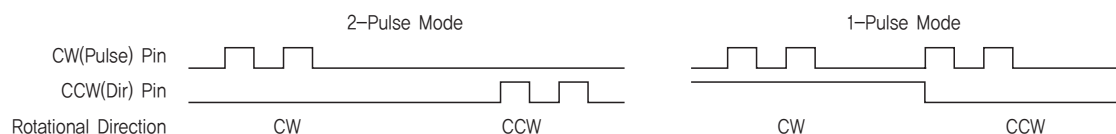
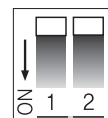

3. Rotational Direction Setting Switch(SW1,2)

Indication	Switch Name	Functions
DIR	Rotational Direction Select Switch	Based on CW(+Dir signal) input to driver. ON: CCW(-Direction) OFF: CW(+Direction) ※ Default: CW mode

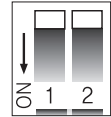

Direction setting switch: ON



CCW Dir.



Direction setting switch: OFF

CW Dir.

4. Run Current Setting Switch(SW2)

SW2 do not used in Ezi-STEP HPB

5. Resolution Setting Switch(SW3)

The Number of pulse per revolution.

Position	Pulse/Revolution	Position	Pulse/Revolution
0	500	8	6,400
1	1,000	9	8,000
2	1,600	A	10,000 ^{*1}
3	2,000	B	20,000
4	3,200	C	25,000
5	3,600	D	36,000
6	4,000	E	40,000
7	5,000	F	50,000

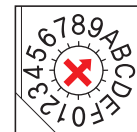

*1 : Default : 10,000

6. Stop Current Setting Switch(SW4)

Stop Current means the motor current value automatically set in 0,1 sec after motor stops. This is to prevent the overheat of a motor when the motor is under long time idling. The unit of the selection value is a percentage.

Position	STOP Current (%)	Position	STOP Current (%)
0	10	5	60
1	20	6	70
2	30	7	80
3	40	8	90
4	50 ^{*1}	9	100

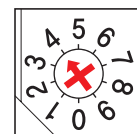

*1 : Default : 50%

7. Power Connector(CN1)

NO.	Function	I/O
1	GND	Input
2	40~70VDC	Input

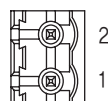

8. Motor Connector(CN2)

NO.	Function	I/O
1	/B Phase	Output
2	B Phase	Output
3	/A Phase	Output
4	A Phase	Output

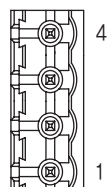

9. Signal Connector(CN3)

NO.	Function	I/O
1	F_GND	----
2	EXT_GND	Input
3	Alarm	Output
4	Run/Stop	Output
5	Alarm Reset	Input
6	EXT_24VDC	Input
7	CCW-(Dir-)	Input
8	CCW+(Dir+)	Input
9	CW-(Pulse-)	Input
10	CW+(Pulse+)	Input

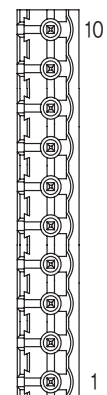

● System Configuration [Ezi-STEP-HPB Series]

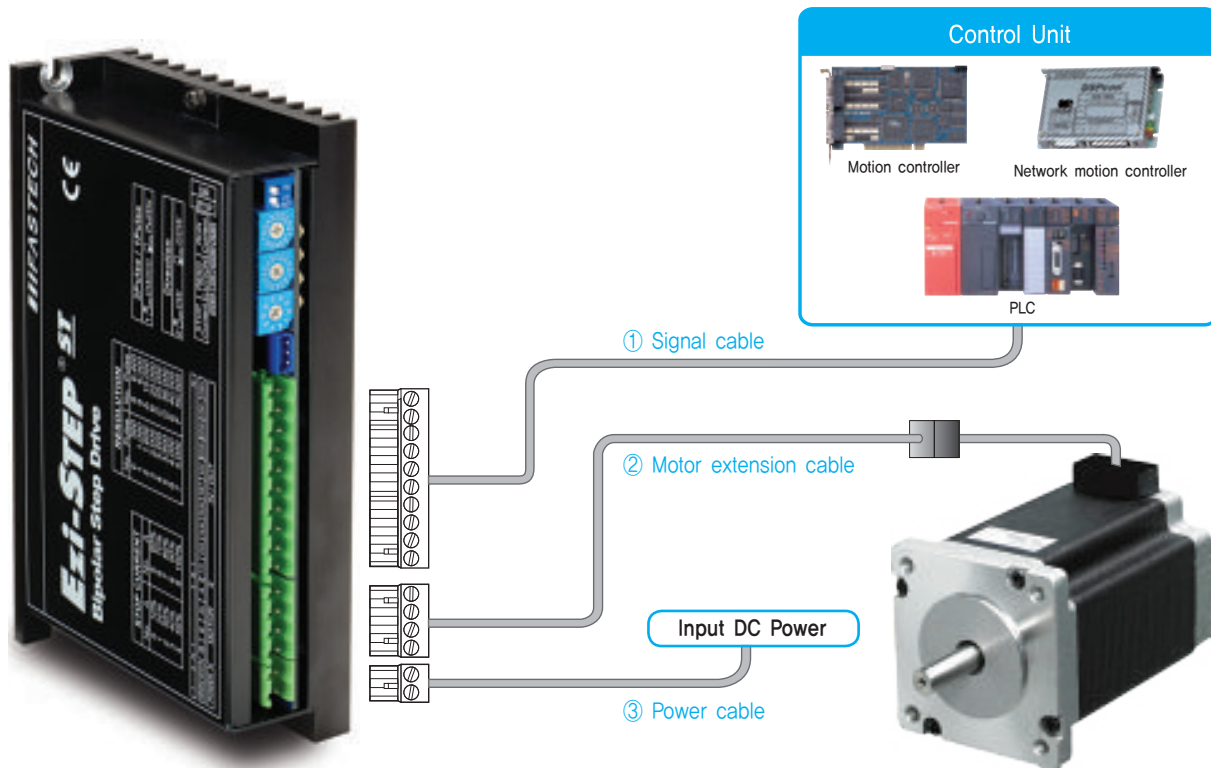

Type	Signal Cable	Motor Cable	Power Cable
Length supplied	-	30cm	-
Max. Length	20m	20m	2m

1. Options

① Signal Cable

Available to connect between Input/Output Control System and Ezi-STEP HPB.

Item	Length [m]	Remark
CHPB-S-□□□F	□□□	Normal Cable
CHPB-S-□□□M	□□□	Robot Cable

□ is for Cable Length. The unit is 1m and Max. 20m length.

② Motor Extension Cable

Available to extended connection between motor and Ezi-STEP HPB.

Item	Length [m]	Remark
CHPB-M-□□□F	□□□	Normal Cable
CHPB-M-□□□M	□□□	Robot Cable

□ is for Cable Length. The unit is 1m and Max. 20m length.

③ Power Cable

Available to connect between Power and Ezi-STEP HPB.

Item	Length [m]	Remark
CSVP-P-□□□F	□□□	Normal Cable
CSVP-P-□□□M	□□□	Robot Cable

□ is for Cable Length. The unit is 1m and Max. 2m length.

2. Connector Specifications

Connector specifications for cabling to drive,

Purpose		Item	Part Number	Manufacturer
Power (CN1)		Terminal Block	AK950-2	PTR
Motor	Drive Side (CN2)	Terminal Block	AK950-4	PTR
	Motor Side	Housing Terminal	3191-4R1 1381T	MOLEX
Signal (CN3)		Terminal Block	AK950-10	PTR

※ Above connector is the most suitable product for the drive applied. Another equivalent connector can be used.

External Wiring Diagram [Ezi-STEP-HPB Series]

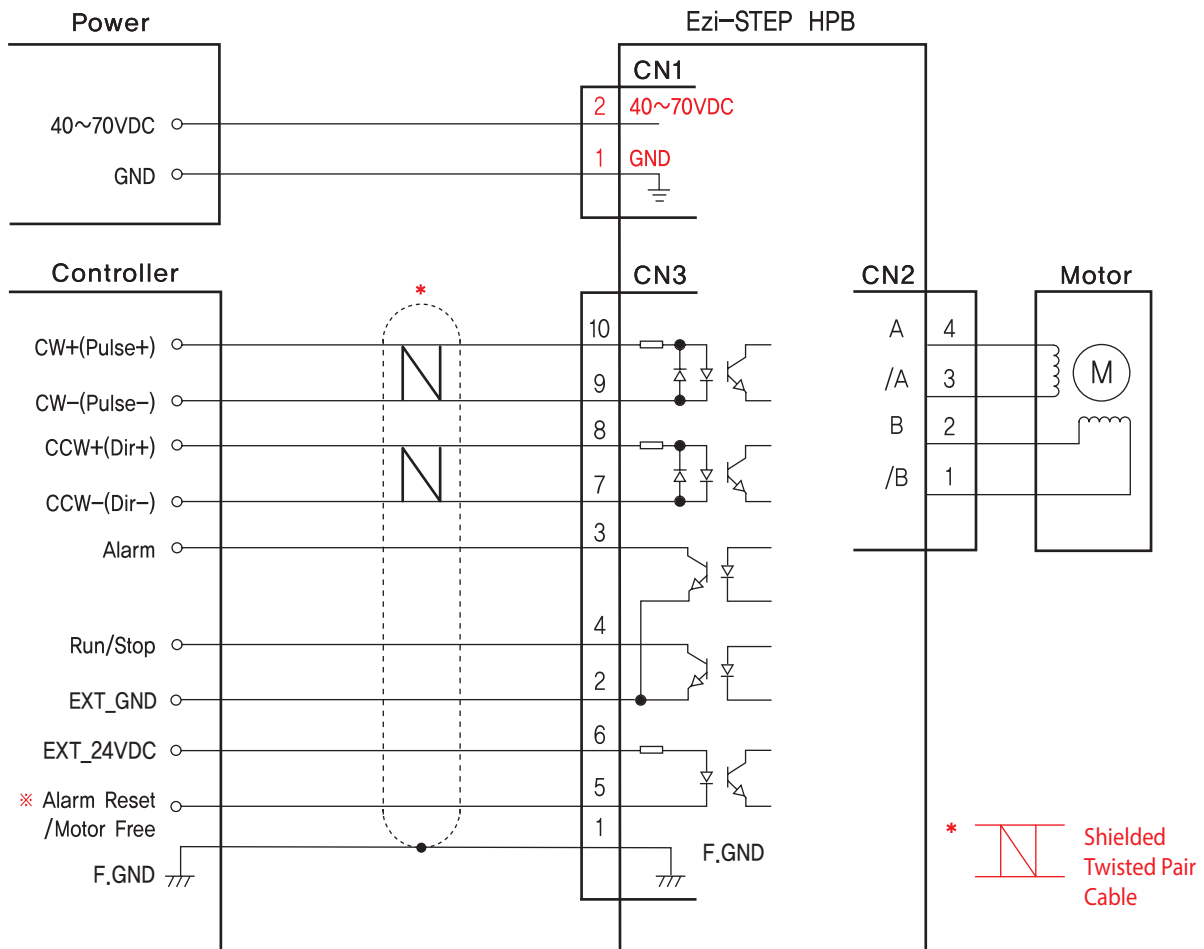

FASTECH Ezi-STEP ST

- ※ Alarm Reset signal line is also used for Motor Free signal.
(For details, please refer to Control Signal Input/Output Description)
- ※ When connects I/O cable between controller and drive, please turn off the power of both controller and drive, in order to protect the drive from any damage.

CAUTION

Please refer to the Manual when connects motor extension cable.
Careful connection will be required to protect the drive from any damages.

Control Signal Input/Output Description

1 Input Signal

Input signals of the drive are all photocoupler protected. The signal shows the status of internal photocouplers [ON: conduction], [OFF: Non-conduction], not displaying the voltage levels of the signal.

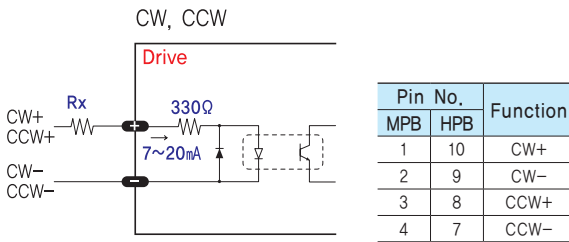

◆ CW, CCW Input

This signal can be used to receive a positioning pulse command from a user host motion controller. The user can select 1-pulse input mode or 2-pulse input mode. The input schematic of CW, CCW is designed for 5V TTL level. When using 5V level as an input signal, the resistor Rx is not used and connect to the driver directly. When the level of input signal is more than 5V, Rx resistor is required. If the resistor is absent, the drive will be damaged. If the input signal level is 12V, Rx value is 680ohm and 24V, Rx value is 1.8Kohm.

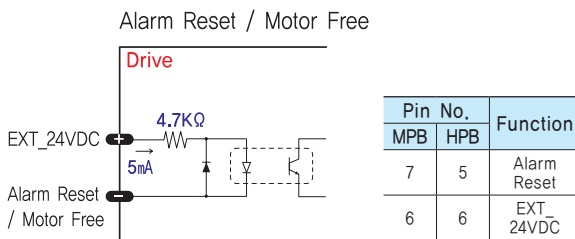

Alarm Reset signal line is also used for Motor Free signal.

◆ Motor Free Input

This input can be used only to adjust the position by manually moving the motor shaft from the load-side. By setting the signal [ON], the drive cuts off the power supply to the motor. Then, one can manually adjust output position. When setting the signal back to [OFF], the drive resumes the power supply to the motor and recovers the holding torque. When driving a motor, one needs to set the signal [OFF]. In normal operations set the signal [OFF] or disconnect a wire to the signal. It operates reversely compare to Normal mode, when you set Inverse mode.

◆ Alarm Reset Input

When a protection mode has been activated, a signal to this Alarm Reset input cancels the Alarm output. By setting the alarm reset input signal [ON], cancel Alarm output. Before cancel the Alarm output, have to remove the source of alarm.

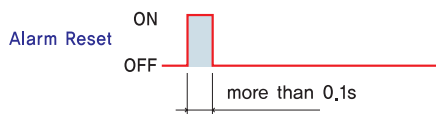

[Caution] If Alarm Reset input signal still remains [ON], motor will be Free state. Keep in mind to change [ON]→[OFF] state.

2 Output Signal

As the output signal from the drive, there are the photocoupler outputs (Alarm, Run/Stop). The signal status operate as [ON : conduction], [OFF : Non-conduction] of photocoupler not as the voltage level of signal.

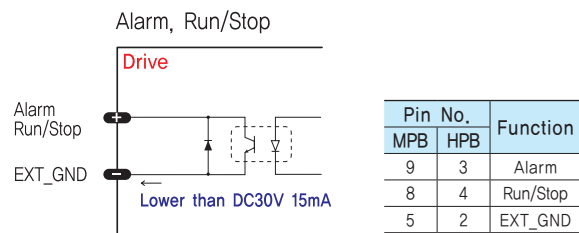

◆ Alarm Output

The Alarm output indicates [OFF] when the drive is in a normal operation. If a protection mode has been activated, it goes [ON]. A host controller needs to detect this signal and stop sending a motor driving command.

When the drive detects an abnormal operation such as overload of overcurrent of a motor, it sets the Alarm output to [ON], flash the Alarm LED, disconnects the power to a motor and stops the motor, simultaneously.

It operates reversely compare to Normal mode, when you set Inverse mode.

◆ Run/Stop Output

Run/Stop Output state is [ON] when motor positioning is completed. It operates reversely compare to Normal mode, when you set inverse mode.

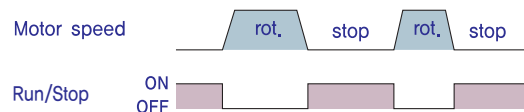

MEMO



Fast, Accurate, Smooth Motion

FASTECH Co., Ltd.

Rm#1202, 401-dong, Bucheon Techno-Park,
655, Pyeongcheon-ro, Bucheon-si Gyeonggi-do,
Republic of Korea (Zip:14502)
TEL : +82-32-234-6300 FAX : +82-32-234-6302
E-mail : sales2@fastech.co.kr
Homepage : www.fastech.co.kr