



YOUR CHOICE OUR COMMITMENT™

MNE® Stepper Motors

STEPPERS



PRODUCT
CATALOG

3 | Stepper Motor Overview

Size 16 Model HY 200 16074
 Size 17 Model HY 200 1713.....5
 Size 17 Model HY 200 1716
 Size 17 Model HY 200 17187
 Size 17 High Performance Model HS 200 17148
 Size 17 High Performance Model HS 200 17169
 Size 17 High Performance Model HS 200 1720.....10
 Size 23 Model HY 200 2215.....11
 Size 23 Model HY 200 2220.....12
 Size 23 Model HY 200 222613
 Size 23 High Performance Model HS 200 221614
 Size 23 High Performance Model HS 200 222115
 Size 23 High Performance Model HS 200 223116
 Size 23 High Performance Model HT 200 2220.....17
 Size 34 Model HN 200 342618
 Size 34 Model HN 200 343819
 Size 34 Model HN 200 345120
 Size 34 High Performance Model HS 200 343721
 Size 34 High Performance Model HS 200 3448.....22
 Size 34 High Performance Model HS 200 3455.....23
 Size 34 High Performance Model HS 200 3462.....24
 Size 34 Synchronous SY 3424.....25
 Size 34 Synchronous SY 343726
 Size 34 Synchronous SY 3450.....27
 Size 42 Model HY 200 427028
 Size 42 Model HY 200 428829

30 | Customizations / Options Size 23

31 | Customizations / Options Size 23

32 | Customizations / Options Size 34

33 | Customizations / Options Size 34

34 | Connection Diagrams

34 | Step Sequence

CATALOG PART NUMBER DESCRIPTION

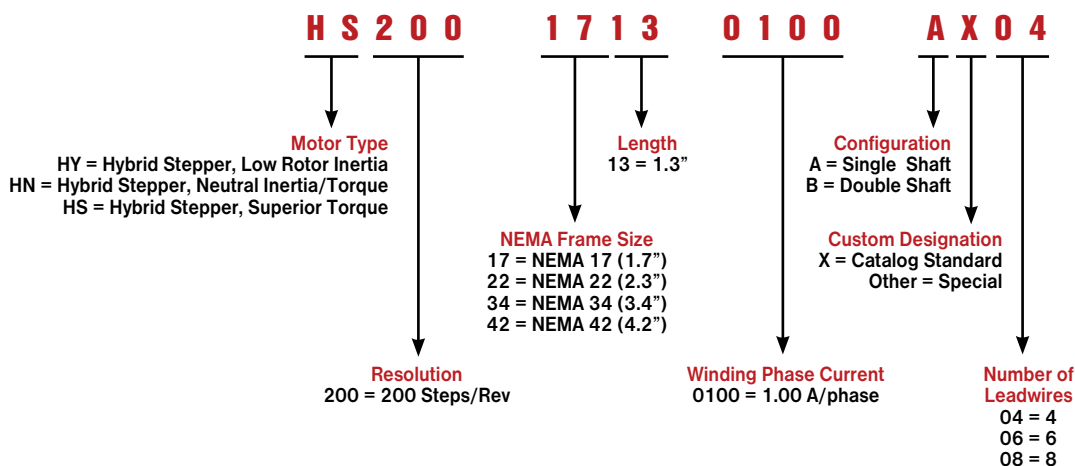

MAE® Stepper Motors



AMETEK® Stepper Motors
EUROPE

offers a wide range of MAE brand stepper motor solutions. The HY series hybrid stepper motors feature low rotor inertia for maximum possible acceleration. The HN series hybrid stepper motors offer a calculated balance between low rotor inertia and high torque. The HS series hybrid stepper motors are optimized for superior torque characteristics. Additionally, both the HN and HS series feature low detent torque to holding torque ratios to provide smooth operation as well as the fine positioning capability required for microstep operation.

Motors may be customized with value added features including but not limited to: gearboxes, encoders, shaft details, leadwire-connector assemblies, and more.

All specifications shown are typical at 20 °C unless otherwise noted.

Shaft extensions

All motors can be supplied with single or double ended shaft.

Rotation

The motor rotation can run clockwise or counterclockwise, depending on the commutation.

Operating temperature

Ambient operating temperature -20 °C to +40 °C.

Number of leads

Refer to specifications of individual models for standard lead wire configuration. Motors can be supplied with 4, 6 or 8 leads upon request; however, rated current and torque may be reduced.

Angular accuracy

Standard angular accuracy is ±5 %. Angular accuracy is defined as the deviation from a theoretical position, in percentage of one step, after any number of steps.

Holding torque

The typical values of holding torque of the different models are indicated in the data charts. Holding torque is measured with two phases each supplied at the rated current.

Specifications and approvals

Motors are manufactured according to EN 60034-1:1995-02. Motors with drive voltage higher than or equal to 120 V are suitable to be fitted on machines equipped with additional insulation or when the motor itself has the grounding through its clamping screws. Due to thermal considerations, stepper motors cannot always be operated continuously in dynamic conditions at the level of their static rated phased current.

Stepper Motors

- Accurate open loop control for high performance positioning applications
- Excellent low speed torque
- Simple, rugged construction for high reliability and long service life
- Smooth, quiet operation
- Standard NEMA frame sizes
- Precision honed stators and ground rotors for tight air gap and maximum performance
- EUROPEAN DIRECTIVES
All motors comply with the requirements of applied European Directives and related Safety Standards

SIZE 16 STEPPER MOTOR DATA

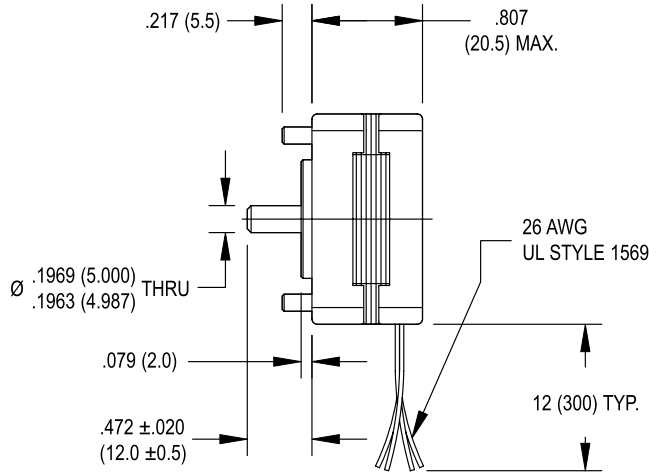
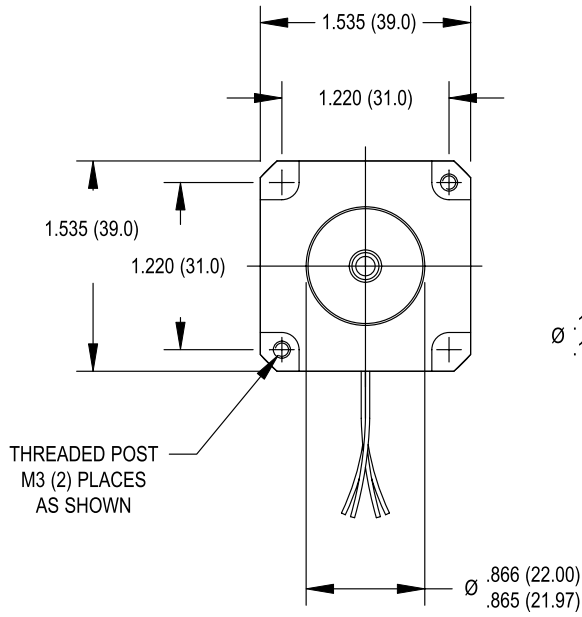

Specification	Units	HY 200 1607	
		0060	
Rated Phase Current	A	0.60	
Phase Resistance	Ω	6.6	
Phase Inductance	mH	8.5	
Holding Torque Unipolar	oz-in Ncm	—	
Holding Torque Bipolar	oz-in Ncm	12 8.7	
Detent Torque	oz-in Ncm	1.4 1.0	
Rotor Inertia	oz-in-s ² × 10 ⁻⁴ g-cm ²	1.6 11	
Motor Weight (Mass)	lb kg	0.33 0.15	
Maximum Voltage	V	40	
Std. No. of Leads	—	4	

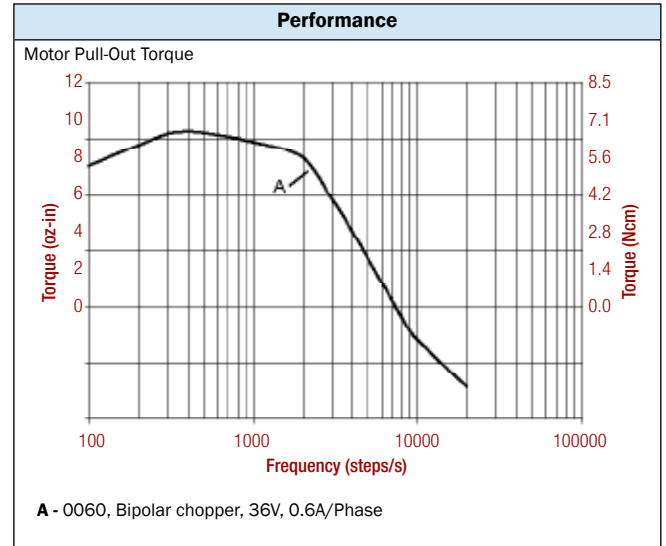

- Standard Features**
- Step angle: 1.8°
 - Step angle accuracy: 5%
 - Insulation class: B (130°C)
 - NEMA 17 mounting configuration
 - Neodymium magnets
 - Additional windings and customization options available

- Complementary Products**
- Gearboxes
 - Encoders

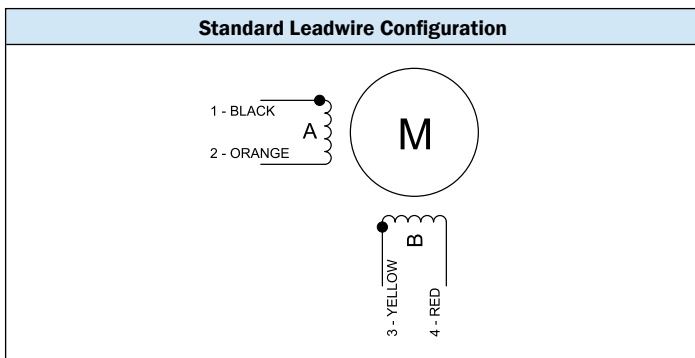

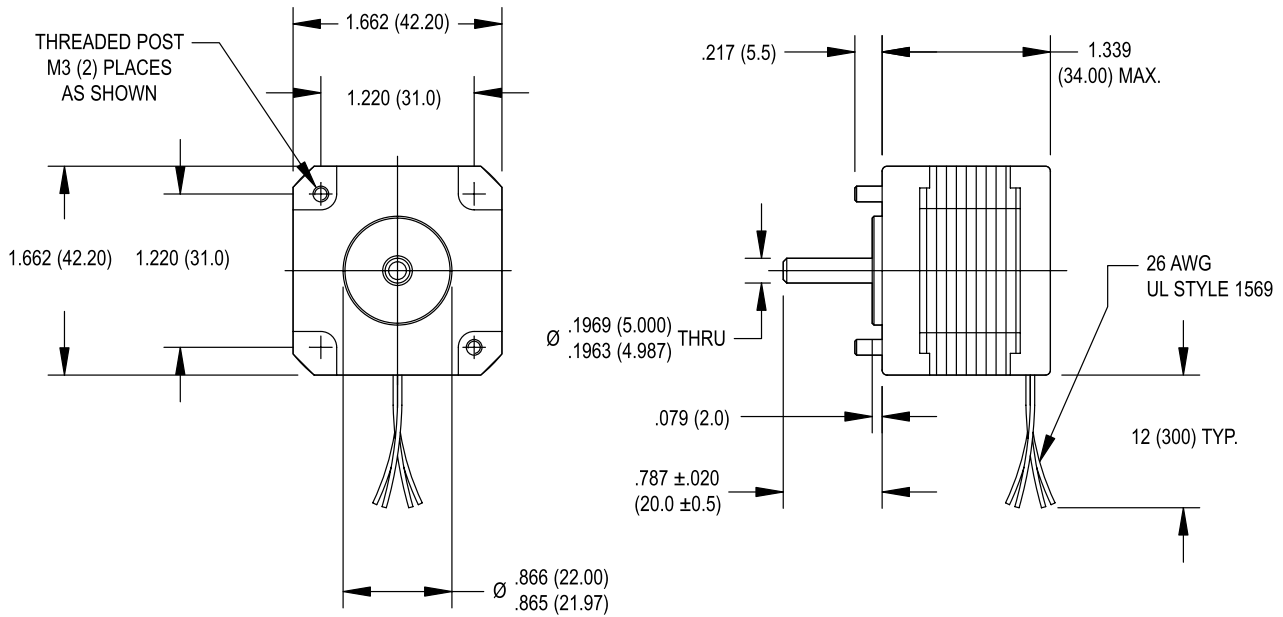

Specification	Units	HY 200 1713	
		0033	0150
Rated Phase Current	A	0.33	1.50
Phase Resistance	Ω	23.9	1.0
Phase Inductance	mH	28.9	1.2
Holding Torque Unipolar	oz-in	—	—
	Ncm	—	—
Holding Torque Bipolar	oz-in	19.4	18.4
	Ncm	13.7	13.0
Detent Torque	oz-in	2.4	2.4
	Ncm	1.7	1.7
Rotor Inertia	oz-in-s ² x10 ⁻⁴	2.5	2.5
	g-cm ²	18	18
Motor Weight (Mass)	lb	0.4	0.4
	kg	0.2	0.2
Maximum Voltage	V	40	40
Std. No. of Leads	—	4	4

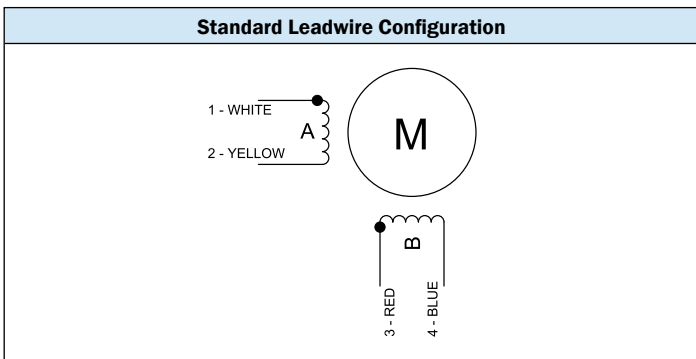
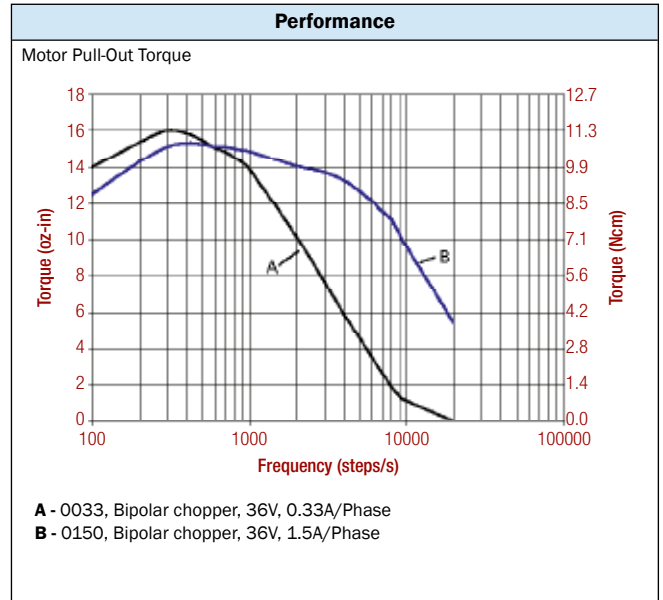

- Standard Features**
- Step angle: 1.8°
 - Step angle accuracy: 5%
 - Insulation class: B (130 °C)
 - NEMA 17 mounting configuration
 - Neodymium magnets
 - Additional windings and customization options available

- Complementary Products**
- Gearboxes
 - Encoders

SIZE 17 STEPPER MOTOR DATA

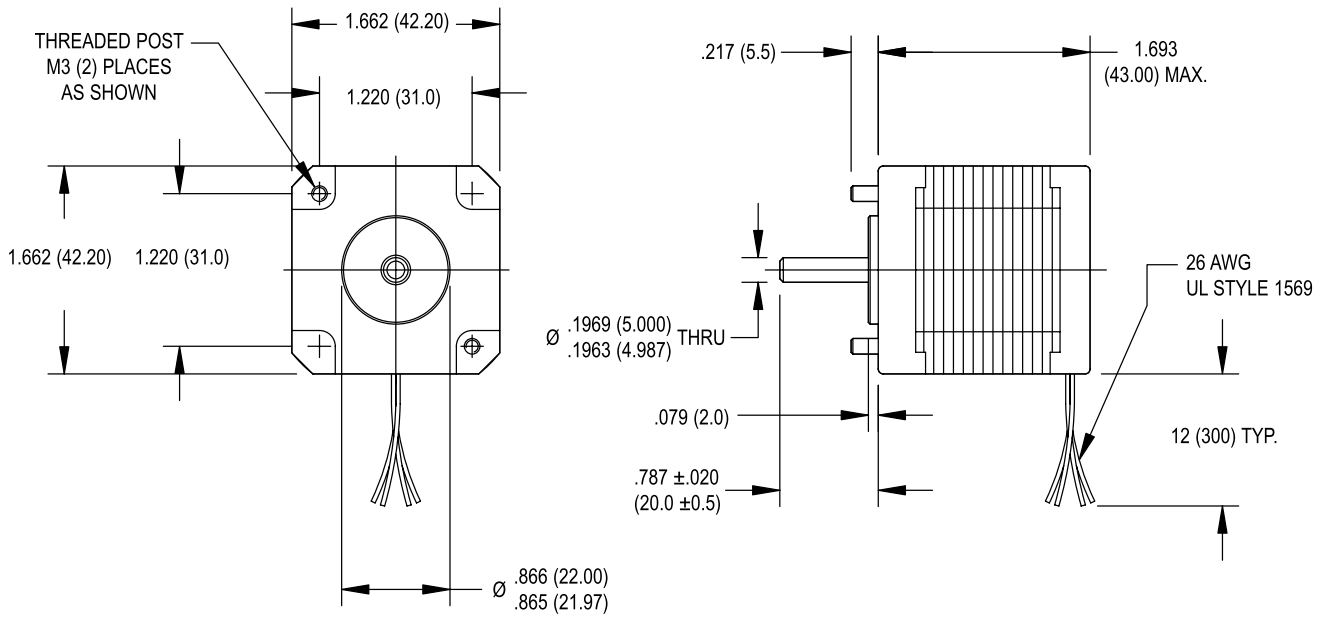

Specification	Units	HY 200 1717	
		0100	
Rated Phase Current	A	1.00	
Phase Resistance	Ω	4.6	
Phase Inductance	mH	10.6	
Holding Torque Unipolar	oz-in Ncm	—	
Holding Torque Bipolar	oz-in Ncm	32.7 23.1	
Detent Torque	oz-in	2.4	
	Ncm	1.7	
Rotor Inertia	oz-in-s ² $\times 10^{-4}$	4.5	
	g-cm ²	32	
Motor Weight (Mass)	lb	0.7	
	kg	0.3	
Maximum Voltage	V	40	
Std. No. of Leads	—	4	

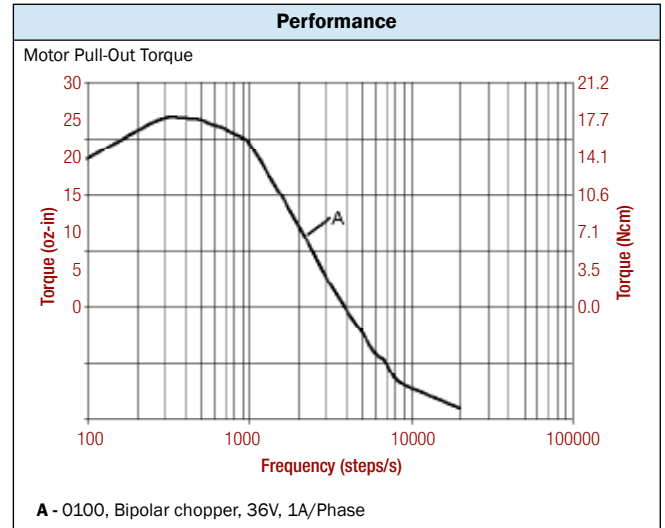

- Standard Features**
- Step angle: 1.8°
 - Step angle accuracy: 5%
 - Insulation class: B (130° C)
 - NEMA 17 mounting configuration
 - Neodymium magnets
 - Additional windings and customization options available

- Complementary Products**
- Gearboxes
 - Encoders

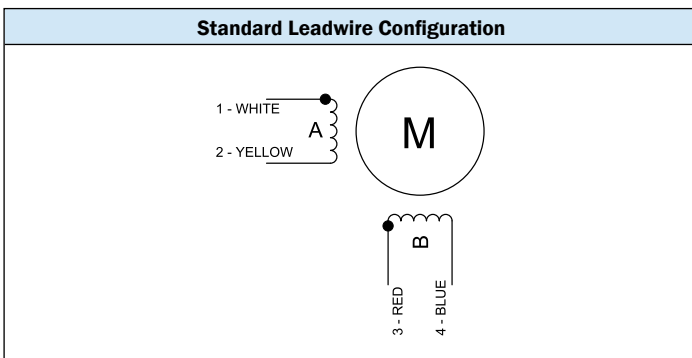

SIZE 17 STEPPER MOTOR DATA

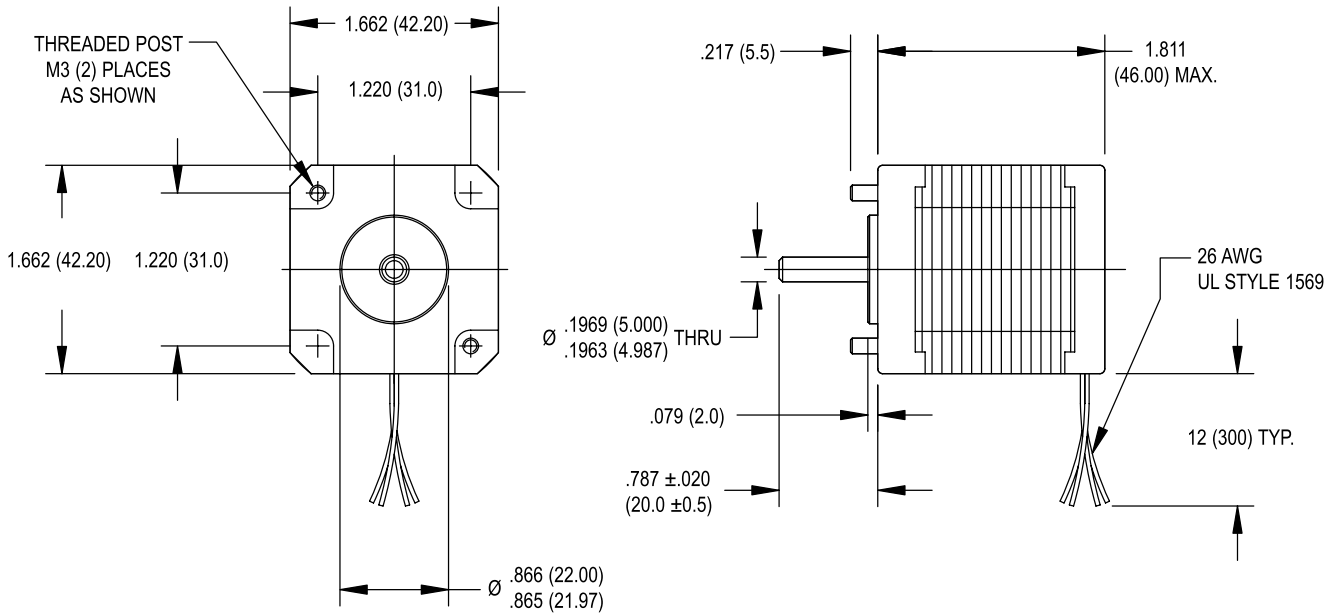

Specification	Units	HY 200 1718	
		0090	0230
Rated Phase Current	A	0.90	2.30
Phase Resistance	Ω	4.2	0.72
Phase Inductance	mH	5.8	0.83
Holding Torque Unipolar	oz-in Ncm	—	—
Holding Torque Bipolar	oz-in Ncm	41.1 29.0	41.1 29.0
Detent Torque	oz-in Ncm	6.4 4.5	6.4 4.5
Rotor Inertia	oz-in-s ² $\times 10^{-4}$ g-cm ²	5.1 36	5.1 36
Motor Weight (Mass)	lb kg	0.7 0.3	0.7 0.3
Maximum Voltage	V	40	40
Std. No. of Leads	—	4	4

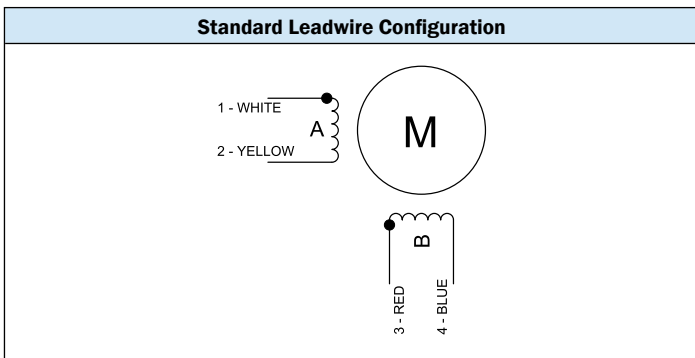
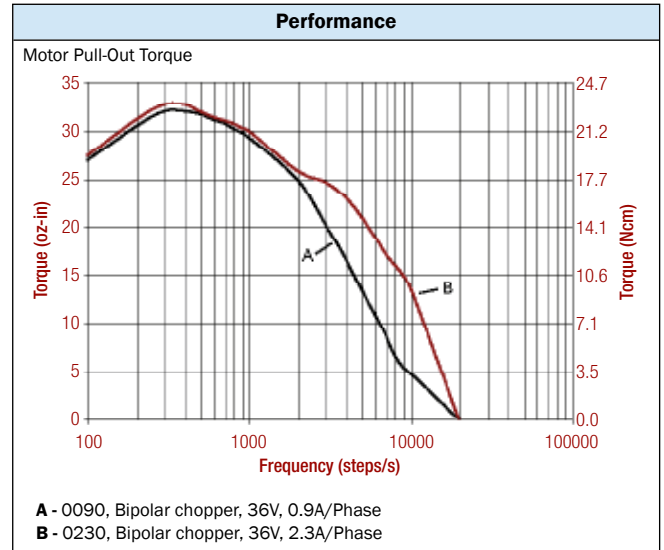

- Standard Features**
- Step angle: 1.8°
 - Step angle accuracy: 5%
 - Insulation class: B (130 °C)
 - NEMA 17 mounting configuration
 - Neodymium magnets
 - Additional windings and customization options available

- Complementary Products**
- Gearboxes
 - Encoders

SIZE 17 HIGH PERFORMANCE STEPPER MOTOR DATA

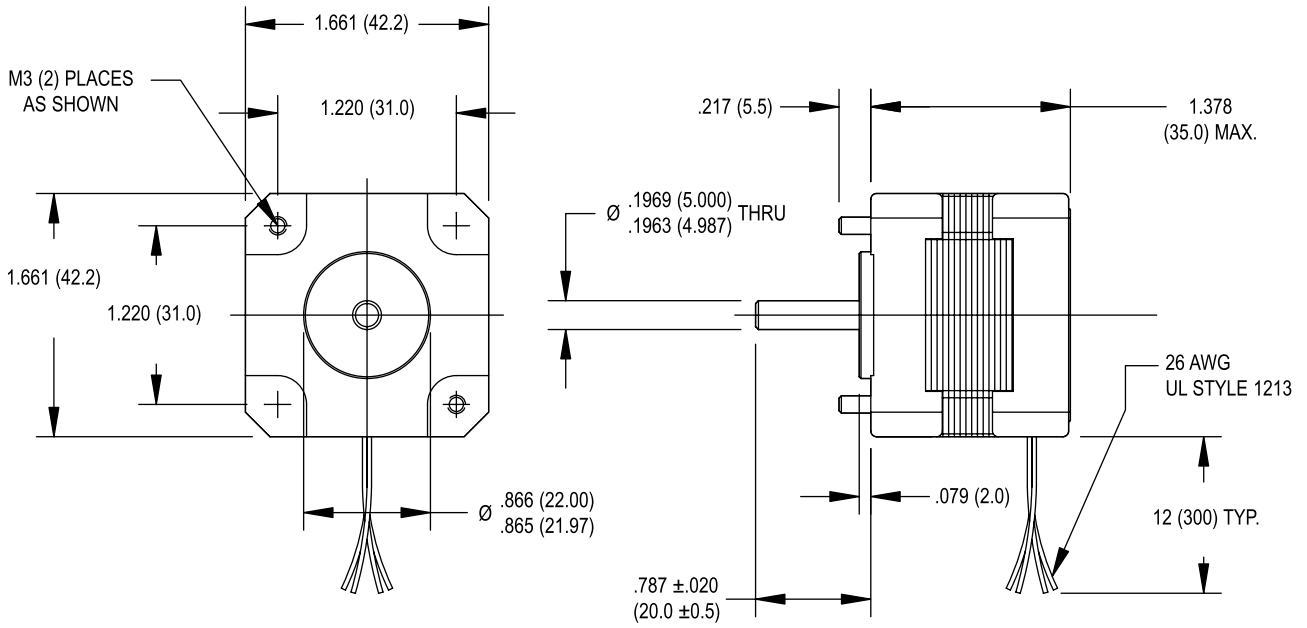

Specification	Units	HS 200 1714		
		0033	0100	0150
Rated Phase Current	A	0.33	1.00	1.50
Phase Resistance	Ω	26.5	2.95	1.25
Phase Inductance	mH	38.8	4.45	1.80
Holding Torque Unipolar	oz-in Ncm	—	—	—
Holding Torque Bipolar	oz-in Ncm	37 26	37 26	37 26
Detent Torque	oz-in Ncm	2.3 1.6	2.3 1.6	2.3 1.6
Rotor Inertia	oz-in-s ² $\times 10^{-4}$ g-cm ²	6.4 45	6.4 45	6.4 45
Motor Weight (Mass)	lb kg	0.51 0.23	0.51 0.23	0.51 0.23
Maximum Voltage	V	40	40	40
Std. No. of Leads	—	4	4	4

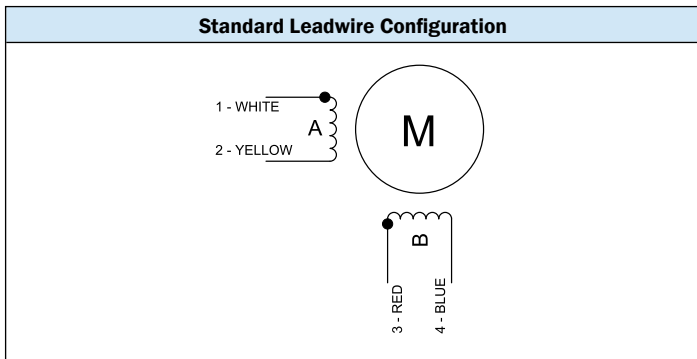
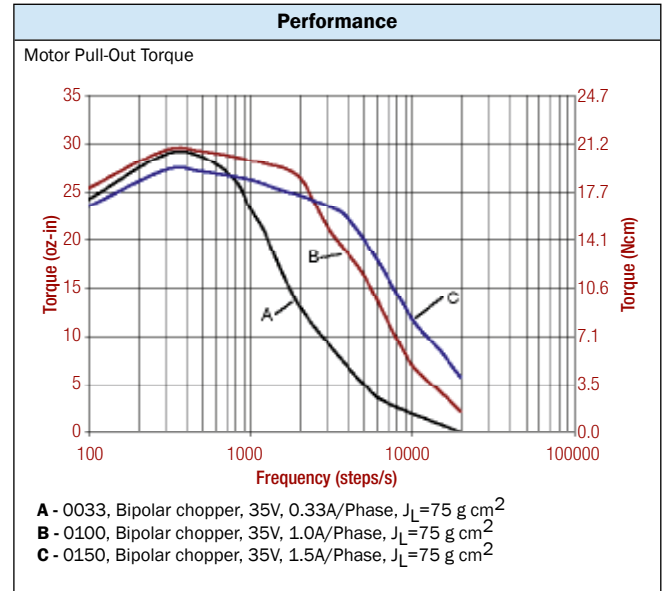

- Standard Features**
- Step angle: 1.8°
 - Step angle accuracy: 5%
 - Insulation class: B (130°C)
 - Optimized for microstep operation
 - NEMA 17 mounting configuration
 - Neodymium magnets
 - Additional windings and customization options available

- Complementary Products**
- Gearboxes
 - Encoders

SIZE 17 HIGH PERFORMANCE STEPPER MOTOR DATA

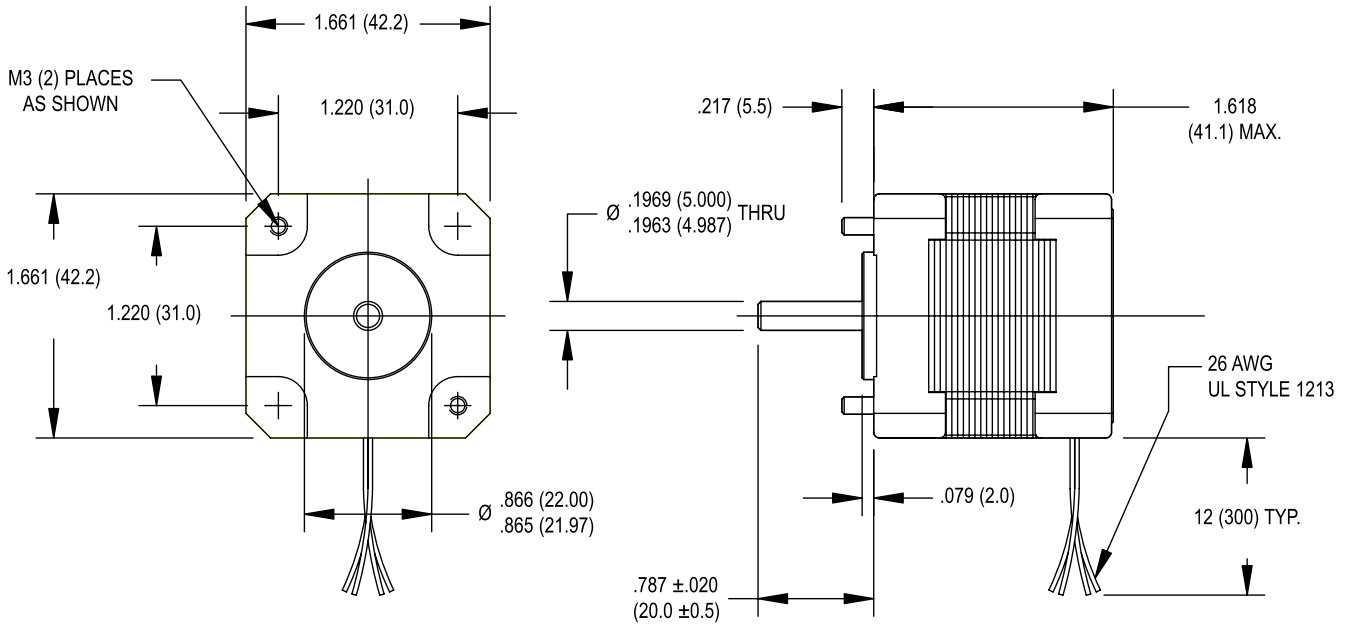

Specification	Units	HS 200 1716		
		0033	0100	0150
Rated Phase Current	A	0.33	1.00	1.50
Phase Resistance	Ω	27.2	2.86	1.40
Phase Inductance	mH	66.7	6.74	3.25
Holding Torque Unipolar	oz-in Ncm	—	—	—
Holding Torque Bipolar	oz-in Ncm	47 33	47 33	47 33
Detent Torque	oz-in Ncm	2.3 1.6	2.3 1.6	2.3 1.6
Rotor Inertia	oz-in-s ² $\times 10^{-4}$ g-cm ²	9.3 66	9.3 66	9.3 66
Motor Weight (Mass)	lb kg	0.66 0.30	0.66 0.30	0.66 0.30
Maximum Voltage	V	40	40	40
Std. No. of Leads	—	4	4	4

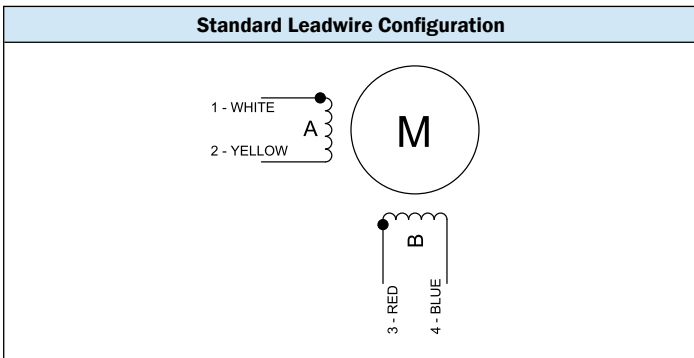
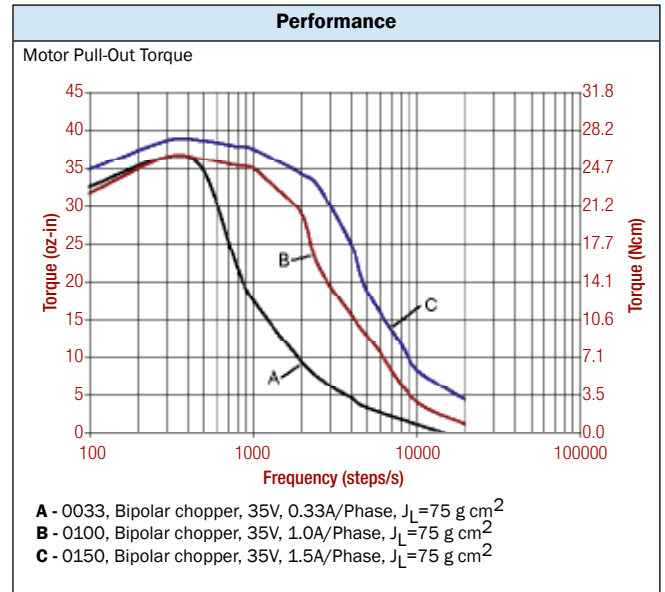

- ### Standard Features
- Step angle: 1.8°
 - Step angle accuracy: 5%
 - Insulation class: B (130°C)
 - Optimized for microstep operation
 - NEMA 17 mounting configuration
 - Neodymium magnets
 - Additional windings and customization options available

- ### Complementary Products
- Gearboxes
 - Encoders

SIZE 17 HIGH PERFORMANCE STEPPER MOTOR DATA

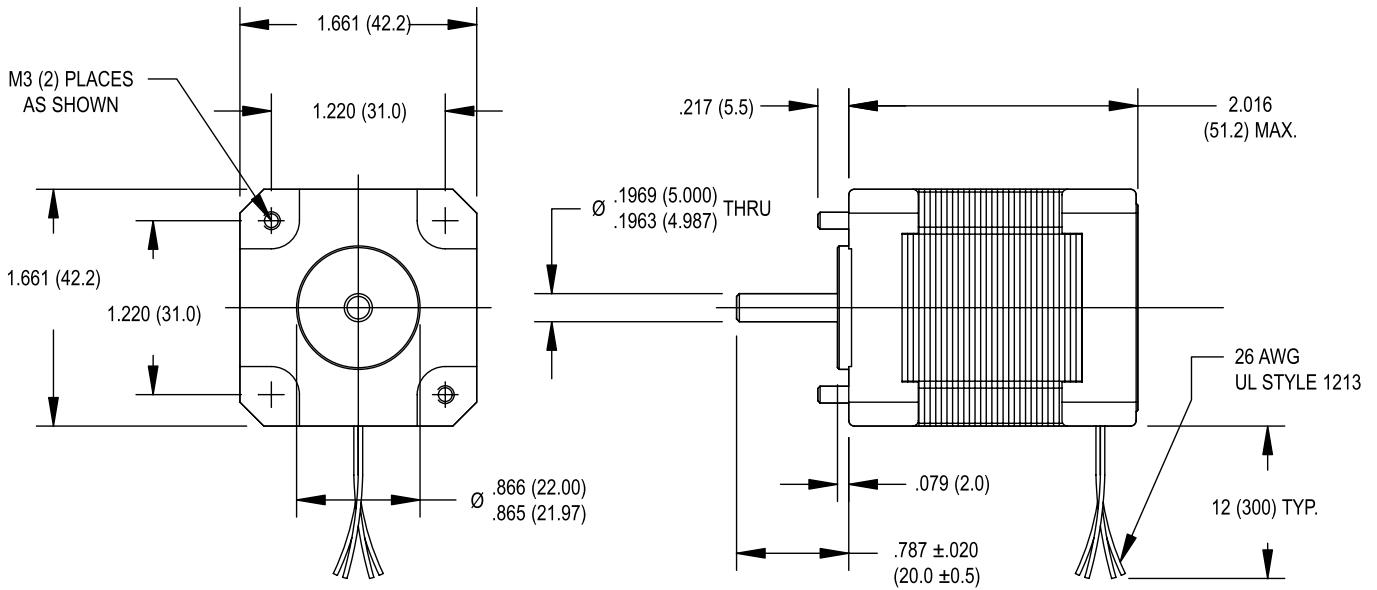

Specification	Units	HS 200 1720		
		0033	0100	0150
Rated Phase Current	A	0.33	1.00	1.50
Phase Resistance	Ω	28.0	3.00	1.45
Phase Inductance	mH	50.0	5.50	2.90
Holding Torque Unipolar	oz-in Ncm	—	—	—
Holding Torque Bipolar	oz-in Ncm	71 50	71 50	71 50
Detent Torque	oz-in Ncm	3.5 2.5	3.5 2.5	3.5 2.5
Rotor Inertia	oz-in-s ² $\times 10^{-4}$ g-cm ²	12.7 90	12.7 90	12.7 90
Motor Weight (Mass)	lb kg	0.84 0.38	0.84 0.38	0.84 0.38
Maximum Voltage	V	40	40	40
Std. No. of Leads	—	4	4	4

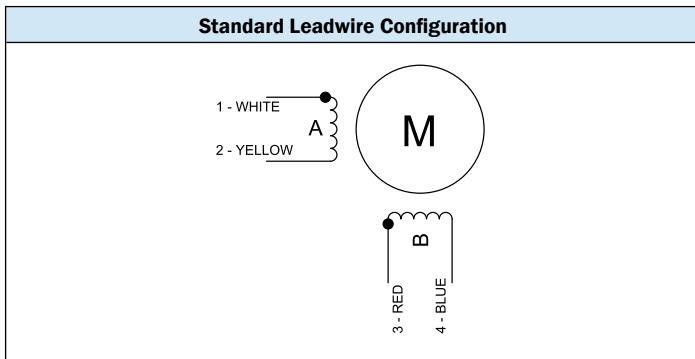
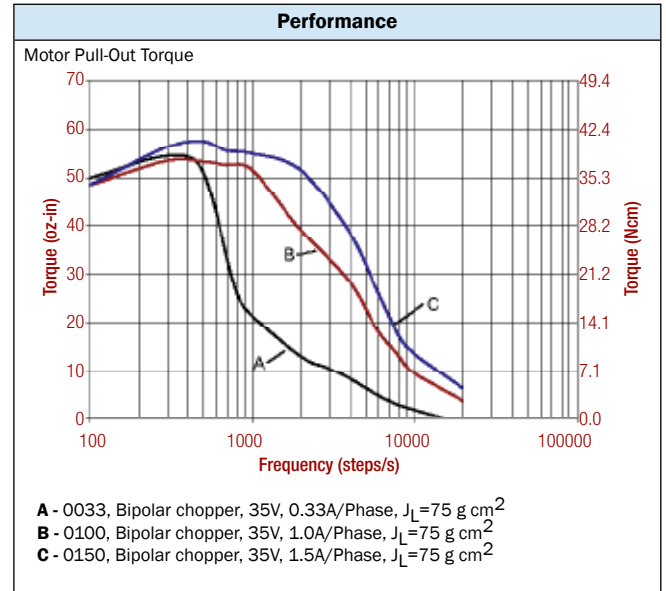

- ### Standard Features
- Step angle: 1.8°
 - Step angle accuracy: 5%
 - Insulation class: B (130°C)
 - Optimized for microstep operation
 - NEMA 17 mounting configuration
 - Neodymium magnets
 - Additional windings and customization options available

- ### Complementary Products
- Gearboxes
 - Encoders

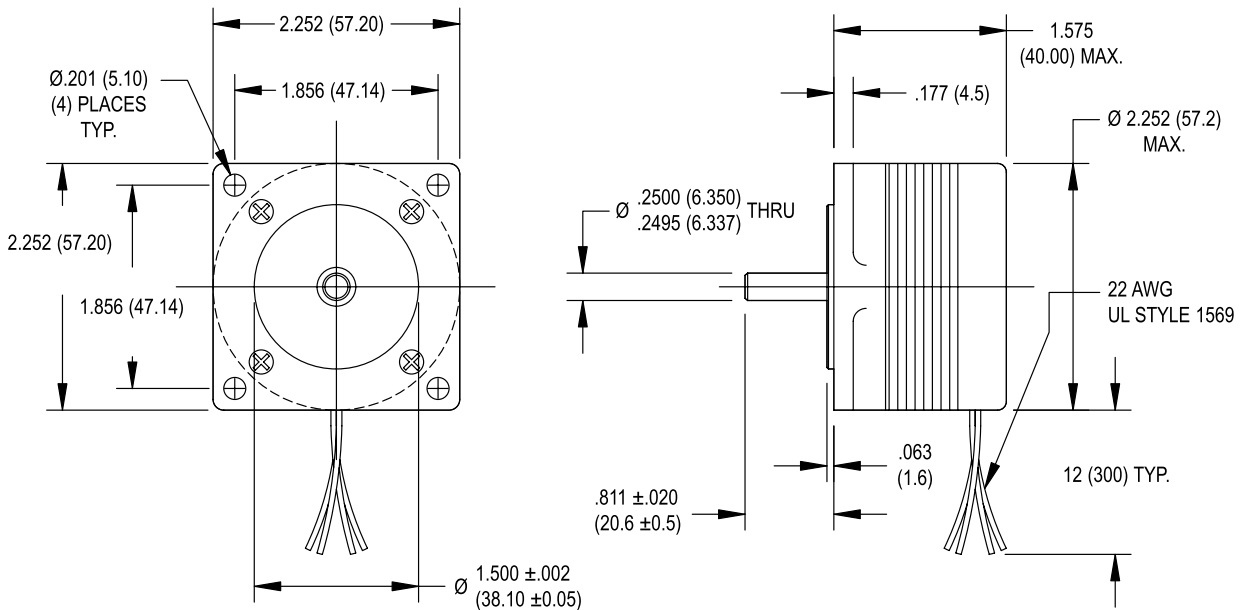

Specification	Units	HY 200 2215			
		0033	0100	0150	0220
Rated Phase Current	A	0.33	1.00	1.50	2.20
Phase Resistance	Ω	33.8	3.4	1.5	0.7
Phase Inductance	mH	54.6	3.8	1.5	1.2
Holding Torque Unipolar	oz-in Ncm	—	38	35	—
Holding Torque Bipolar	oz-in Ncm	45 32	48 34	47 33	44 31
Detent Torque	oz-in Ncm	4.8 3.4	4.8 3.4	4.8 3.4	4.8 3.4
Rotor Inertia	oz-in-s ² $\times 10^{-4}$ g-cm ²	7.9 56	7.9 56	7.9 56	7.9 56
Motor Weight (Mass)	lb kg	0.75 0.34	0.75 0.34	0.75 0.34	0.75 0.34
Maximum Voltage	V	75	75	75	75
Std. No. of Leads	—	4	8	8	4

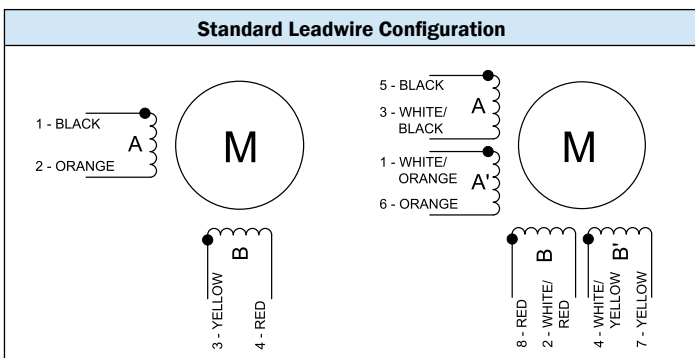
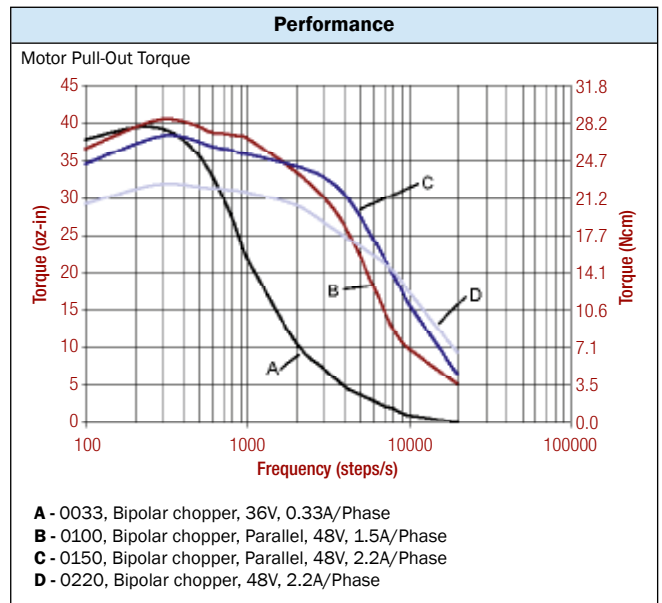

- Standard Features**
- Step angle: 1.8°
 - Step angle accuracy: 5%
 - Insulation class: B (130 °C)
 - NEMA 23 mounting configuration
 - AlNiCo magnets
 - Additional windings and customization options available

- Complementary Products**
- Gearboxes
 - Encoders

SIZE 23 STEPPER MOTOR DATA

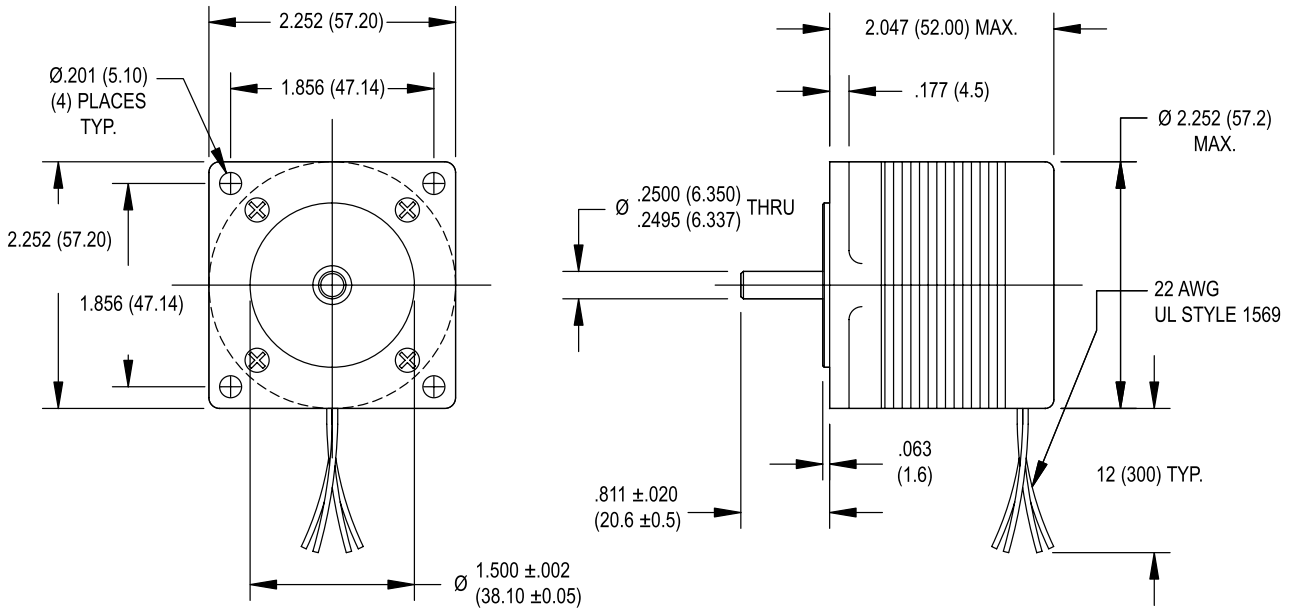

Specification	Units	HY 200 2220		
		0044	0100	0210
Rated Phase Current	A	0.44	1.00	2.10
Phase Resistance	Ω	23.0	5.0	1.1
Phase Inductance	mH	39.2	8.0	1.7
Holding Torque Unipolar	oz-in	74	75	74
	Ncm	52	53	52
Holding Torque Bipolar	oz-in	92	98	91
	Ncm	65	69	64
Detent Torque	oz-in	7.5	7.5	7.5
	Ncm	5.3	5.3	5.3
Rotor Inertia	oz-in-s ² x10 ⁻⁴	17.6	17.6	17.6
	g-cm ²	124	124	124
Motor Weight (Mass)	lb	1.1	1.1	1.1
	kg	0.50	0.50	0.50
Maximum Voltage	V	75	75	75
Std. No. of Leads	-	8	8	8

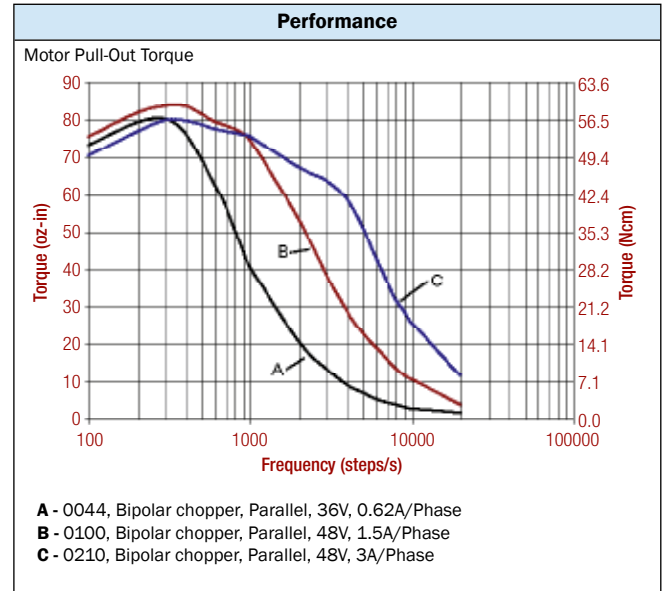

Available through the MotionExpress program.

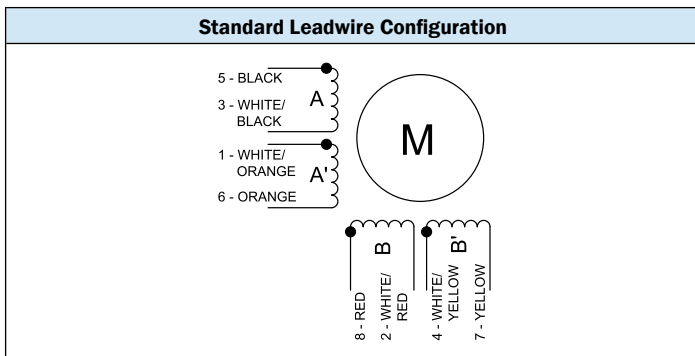

- ### Standard Features
- Step angle: 1.8°
 - Step angle accuracy: 5%
 - Insulation class: B (130°C)
 - NEMA 23 mounting configuration
 - AlNiCo magnets
 - Additional windings and customization options available

- ### Complementary Products
- Gearboxes
 - Encoders

SIZE 23 STEPPER MOTOR DATA

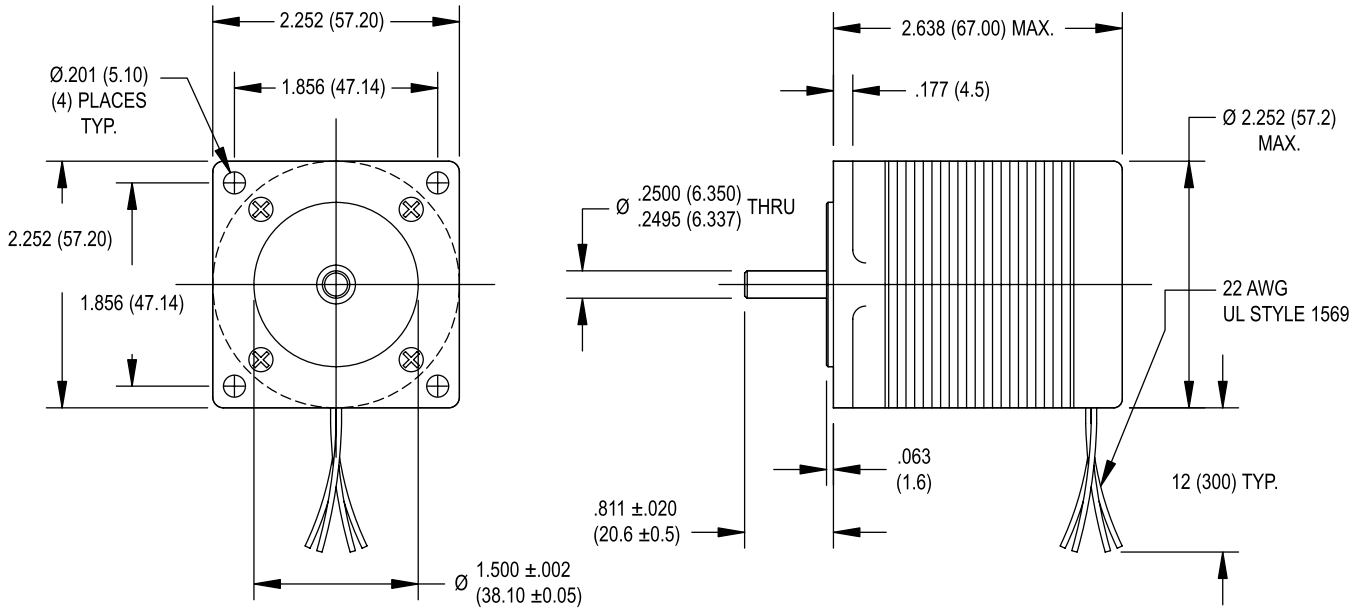

Specification	Units	HY 200 2226			
		0160	0190	0250	0470
Rated Phase Current	A	1.60	1.90	2.50	4.70
Phase Resistance	Ω	2.6	1.8	1.1	0.33
Phase Inductance	mH	4.7	3.3	4.0	0.5
Holding Torque Unipolar	oz-in	123	126	—	123
	Ncm	87	89	—	87
Holding Torque Bipolar	oz-in	154	160	161	154
	Ncm	109	113	114	109
Detent Torque	oz-in	12.0	12.0	12.0	12.0
	Ncm	8.5	8.5	8.5	8.5
Rotor Inertia	oz-in-s ² x10 ⁻⁴	28	28	28	28
	g-cm ²	200	200	200	200
Motor Weight (Mass)	lb	1.5	1.5	1.5	1.5
	kg	0.70	0.70	0.70	0.70
Maximum Voltage	V	75	75	75	75
Std. No. of Leads	—	8	8	4	8

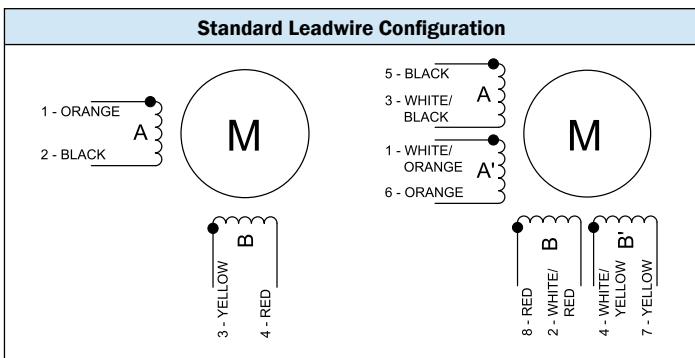
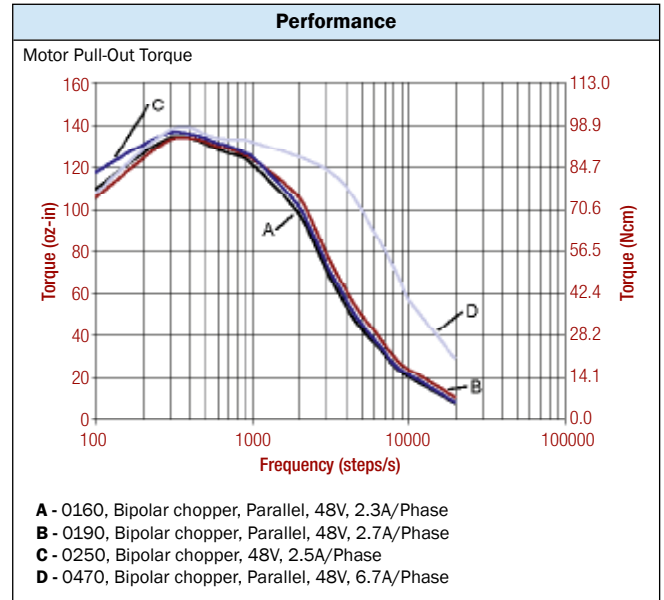

- ### Standard Features
- Step angle: 1.8°
 - Step angle accuracy: 5%
 - Insulation class: B (130 °C)
 - NEMA 23 mounting configuration
 - Neodymium magnets
 - Additional windings and customization options available

- ### Complementary Products
- Gearboxes
 - Encoders

SIZE 23 HIGH PERFORMANCE STEPPER MOTOR DATA

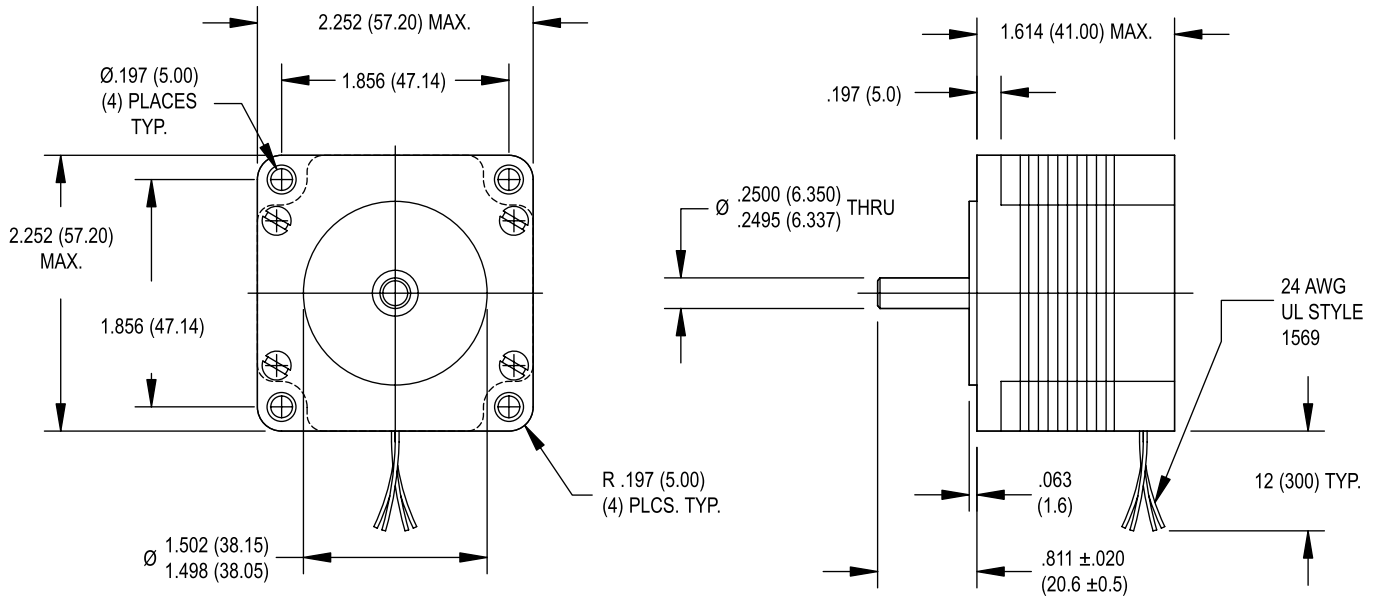

Specification	Units	HS 200 2216	
		0100	0210
Rated Phase Current	A	1.00	2.10
Phase Resistance	Ω	4.6	1.0
Phase Inductance	mH	4.6	2.1
Holding Torque Unipolar	oz-in Ncm	52 37	—
Holding Torque Bipolar	oz-in Ncm	67 47	67 47
Detent Torque	oz-in Ncm	3.0 2.1	3.0 2.1
Rotor Inertia	oz-in-s ² $\times 10^{-4}$ g-cm ²	11 77	11 77
Motor Weight (Mass)	lb kg	1.1 0.50	1.1 0.50
Maximum Voltage	V	75	75
Std. No. of Leads	—	8	4

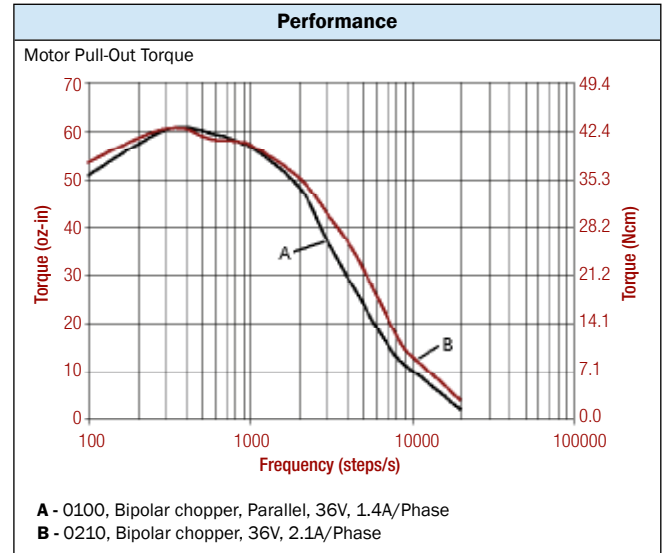

- ### Standard Features
- Step angle: 1.8°
 - Step angle accuracy: 5%
 - Insulation class: B (130°C)
 - Optimized for microstep operation
 - NEMA 23 mounting configuration
 - Neodymium magnets
 - Additional windings and customization options available

- ### Complementary Products
- Gearboxes
 - Encoders

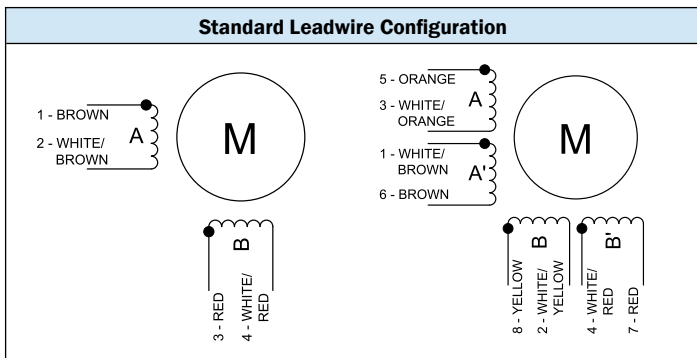

SIZE 23 HIGH PERFORMANCE STEPPER MOTOR DATA

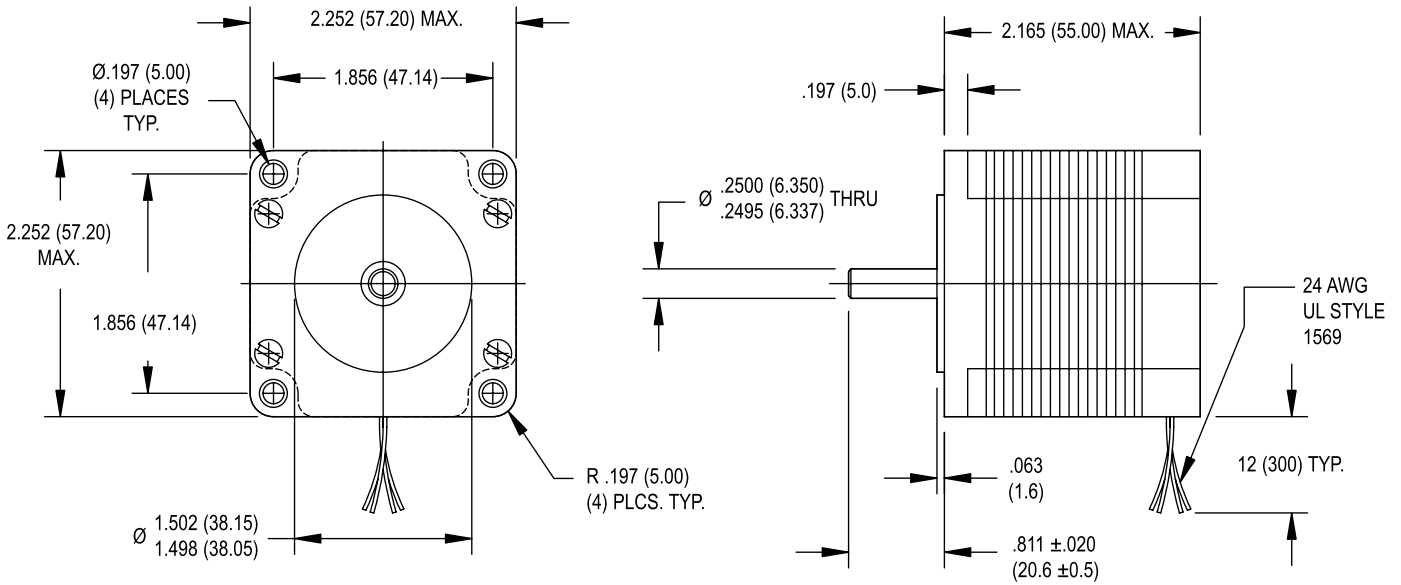

Specification	Units	HS 200 2221		
		0100	0210	0300
Rated Phase Current	A	1.00	2.10	3.00
Phase Resistance	Ω	6.2	1.4	0.7
Phase Inductance	mH	8.8	3.9	0.9
Holding Torque Unipolar	oz-in	106	—	106
	Ncm	75	—	75
Holding Torque Bipolar	oz-in	139	139	139
	Ncm	98	98	98
Detent Torque	oz-in	5.7	5.7	5.7
	Ncm	4.0	4.0	4.0
Rotor Inertia	oz-in-s ² x10 ⁻⁴	31	31	31
	g-cm ²	220	220	220
Motor Weight (Mass)	lb	1.5	1.5	1.5
	kg	0.70	0.70	0.70
Maximum Voltage	V	75	75	75
Std. No. of Leads	—	8	4	8

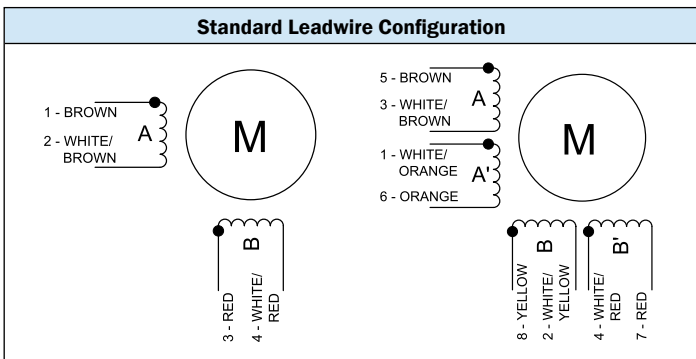
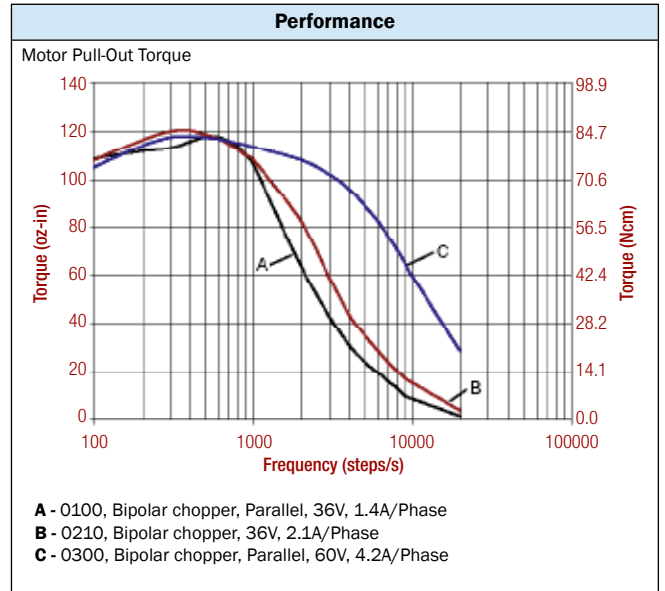

- ### Standard Features
- Step angle: 1.8°
 - Step angle accuracy: 5%
 - Insulation class: B (130 °C)
 - Optimized for microstep operation
 - NEMA 23 mounting configuration
 - AlNiCo magnets
 - Additional windings and customization options available

- ### Complementary Products
- Gearboxes
 - Encoders

SIZE 23 HIGH PERFORMANCE STEPPER MOTOR DATA

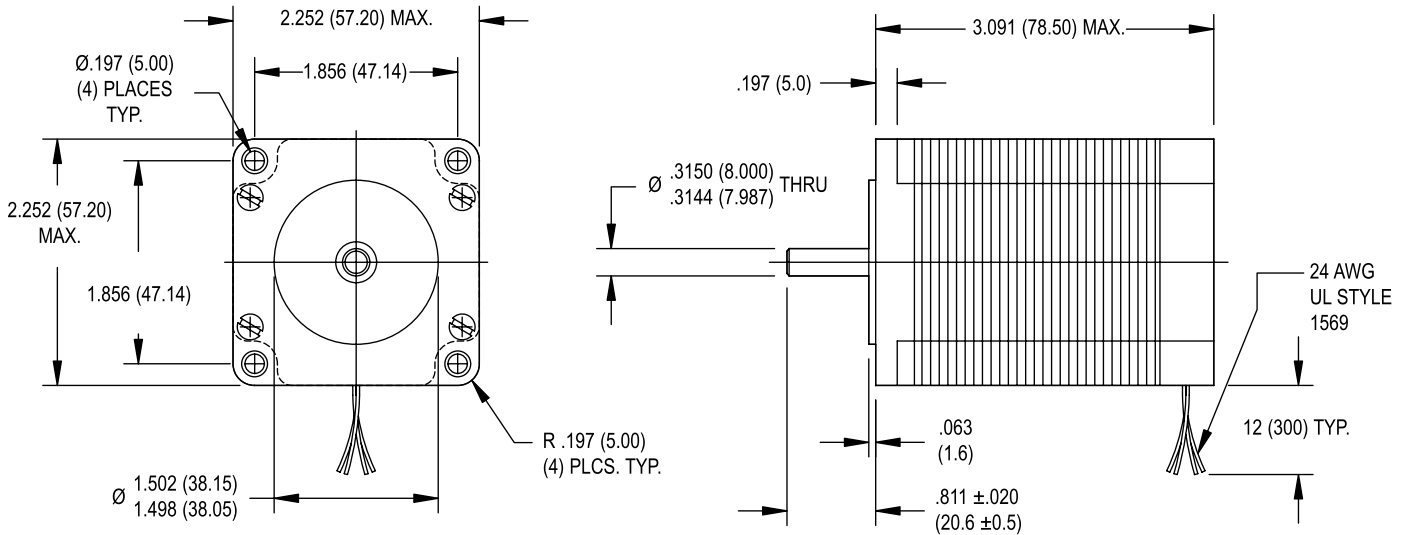

Specification	Units	HS 200 2231	
		0210	0300
Rated Phase Current	A	2.10	3.00
Phase Resistance	Ω	2.0	1.1
Phase Inductance	mH	6.5	1.7
Holding Torque Unipolar	oz-in Ncm	—	177 125
Holding Torque Bipolar	oz-in Ncm	228 161	231 163
Detent Torque	oz-in Ncm	9.6 6.8	9.6 6.8
Rotor Inertia	oz-in-s ² $\times 10^{-4}$ g-cm ²	48 340	48 340
Motor Weight (Mass)	lb kg	2.2 1.0	2.2 1.0
Maximum Voltage	V	75	75
Std. No. of Leads	—	4	8

Available through the MotionExpress program.

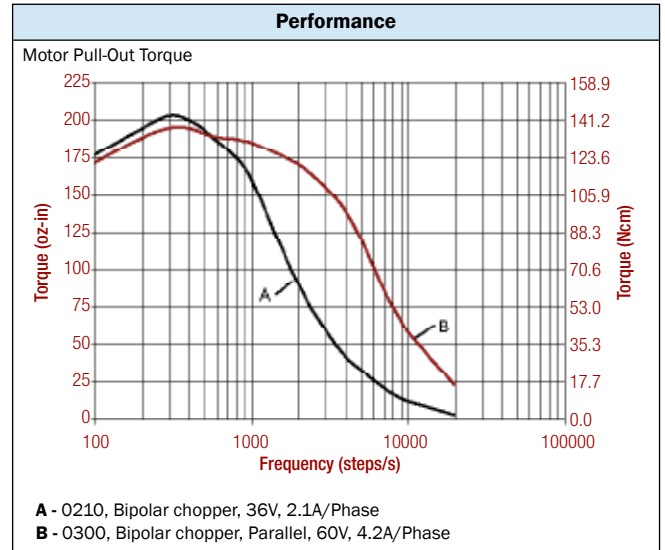

- Standard Features**
- Step angle: 1.8°
 - Step angle accuracy: 5%
 - Insulation class: B (130°C)
 - Optimized for microstep operation
 - NEMA 23 mounting configuration
 - AlNiCo magnets
 - Additional windings and customization options available

- Complementary Products**
- Gearboxes
 - Encoders

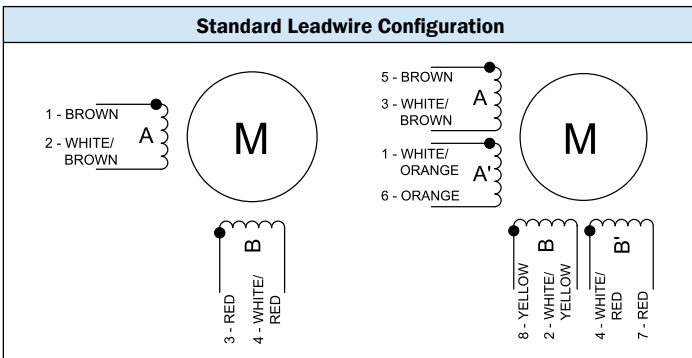

SIZE 23 HIGH PERFORMANCE STEPPER MOTOR DATA

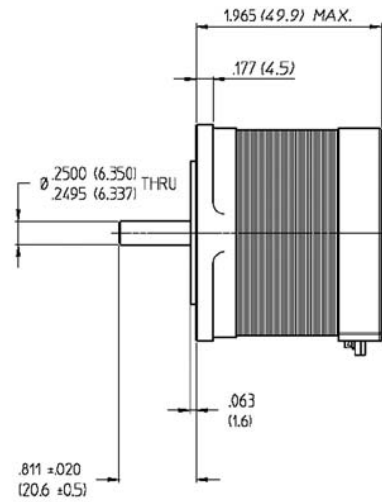
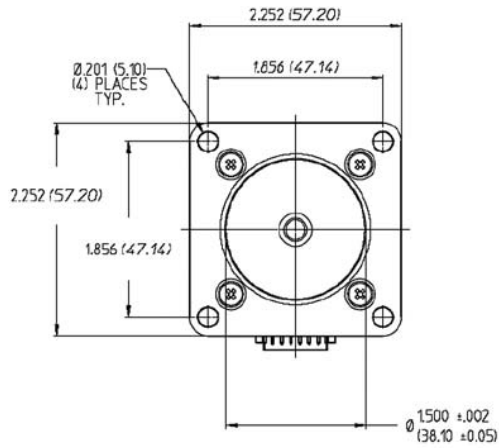

Specification	Units	HT 200 2220
		0200
Rated Phase Current	A	2.00
Phase Resistance	Ω	1.20
Phase Inductance	mH	3.40
Holding Torque Bipolar	oz-in	113
	Ncm	80
Detent Torque	oz-in	8.5
	Ncm	6
Rotor Inertia	oz-in-s ² x10 ⁻⁴	18.7
	g-cm ²	132
Motor Weight (Mass)	lb	1.1
	kg	0.5
Maximum Voltage	V	75

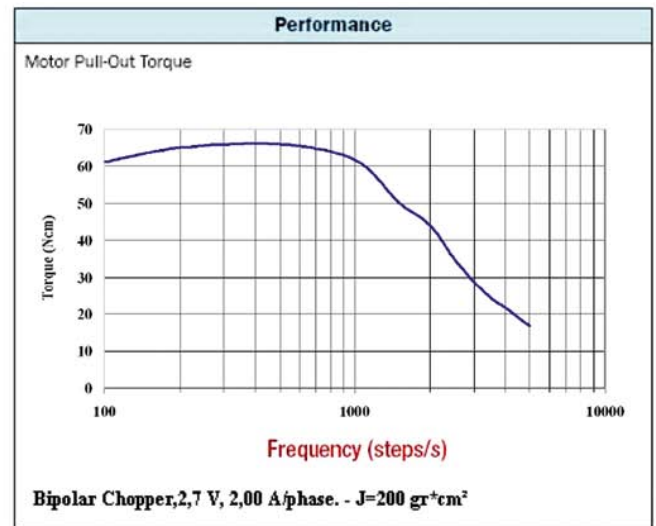

- ### Standard Features
- Step angle: 1.8°
 - Step angle accuracy: 5%
 - Insulation class: B (130°C)
 - NEMA 23 mounting configuration
 - Additional windings and customization options available

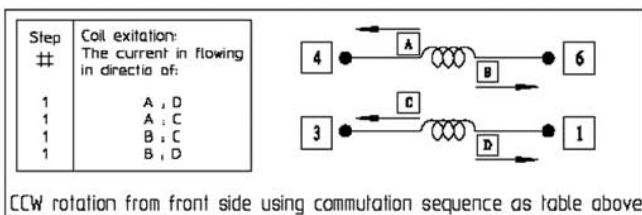
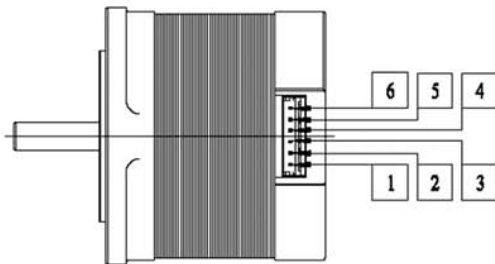

SIZE 34 STEPPER MOTOR DATA

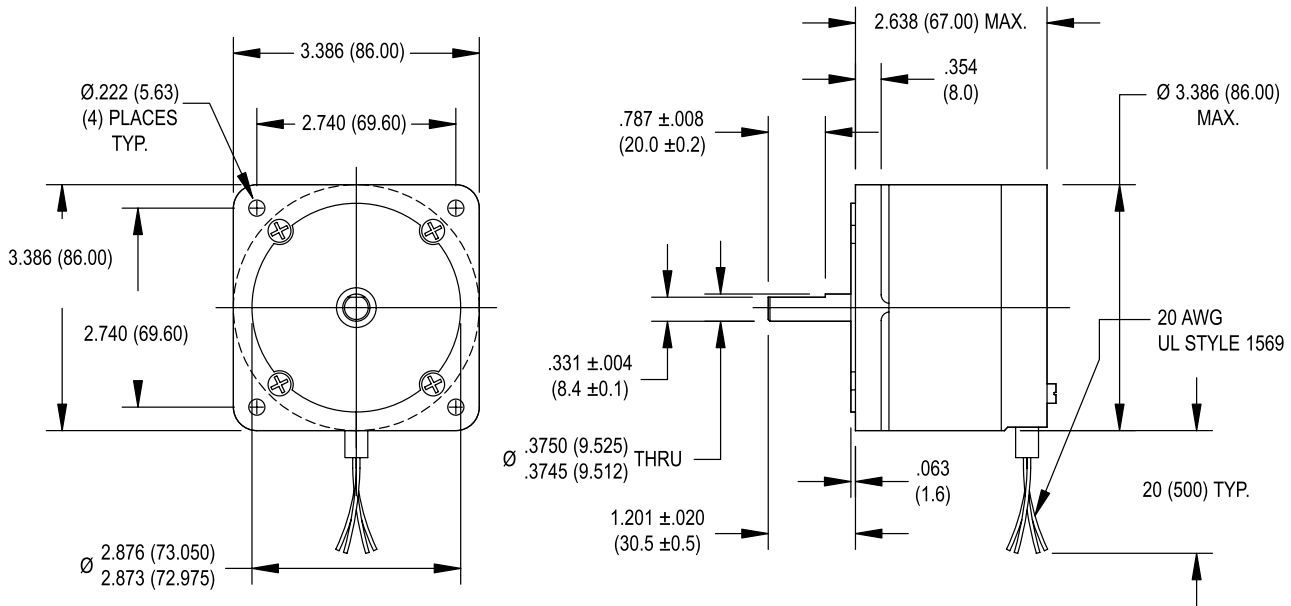

Specification	Units	HN 200 3426		
		0140	0280	0430
Rated Phase Current	A	1.40	2.80	4.30
Phase Resistance	Ω	5.0	1.3	0.55
Phase Inductance	mH	21	5.1	2.1
Holding Torque Unipolar	oz-in	326	326	326
	Ncm	230	230	230
Holding Torque Bipolar	oz-in	397	397	397
	Ncm	280	280	280
Detent Torque	oz-in	12	12	12
	Ncm	8.5	8.5	8.5
Rotor Inertia	oz-in-s ² $\times 10^{-4}$	93	93	93
	g-cm ²	660	660	660
Motor Weight (Mass)	lb	3.5	3.5	3.5
	kg	1.6	1.6	1.6
Maximum Voltage	V	90	90	90
Std. No. of Leads	—	8	8	8

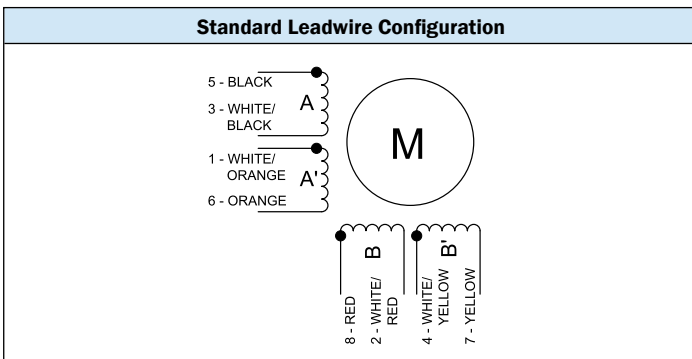
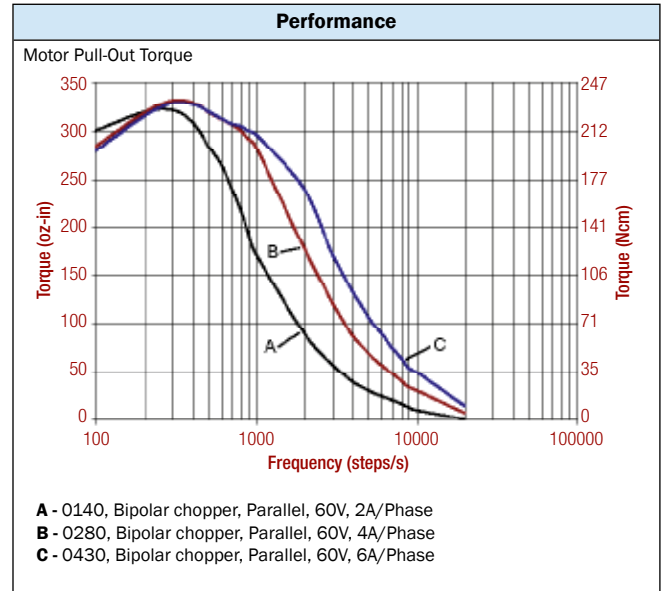

- Standard Features**
- Step angle: 1.8°
 - Step angle accuracy: 5%
 - Insulation class: B (130°C)
 - NEMA 34 mounting configuration
 - Neodymium magnets
 - Additional windings and customization options available

- Complementary Products**
- Gearboxes
 - Encoders

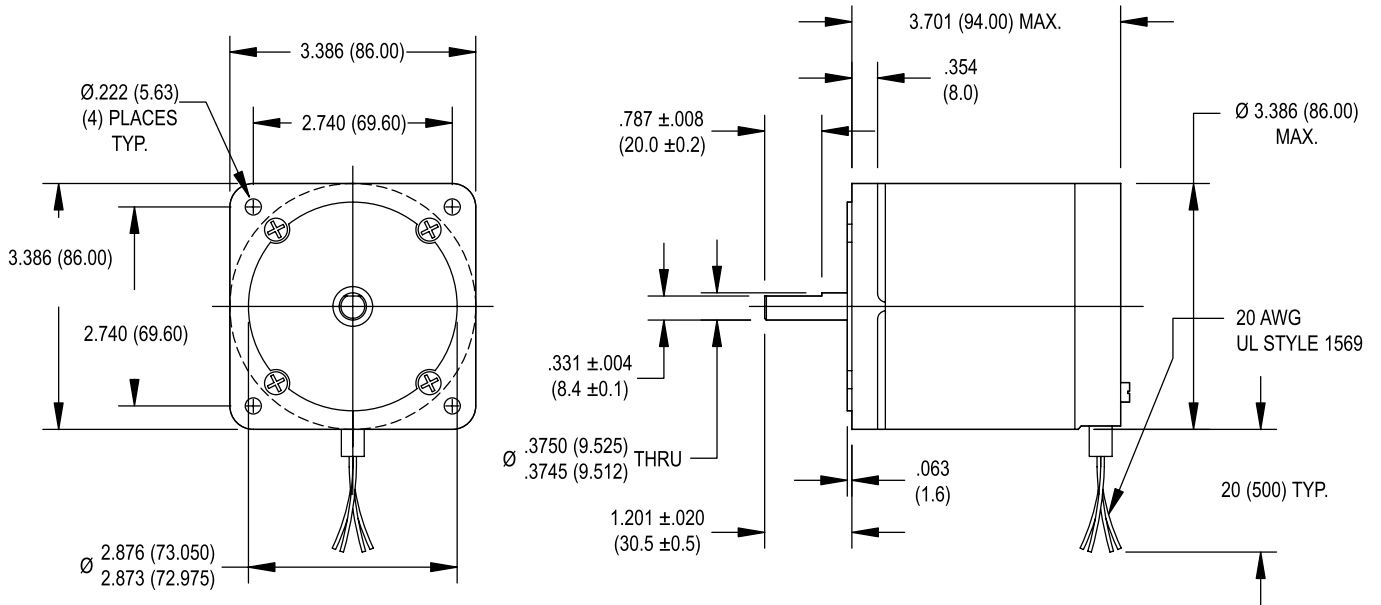

Specification	Units	HN 200 3438	
		0280	0430
Rated Phase Current	A	2.80	4.30
Phase Resistance	Ω	1.7	0.75
Phase Inductance	mH	7.7	3.5
Holding Torque Unipolar	oz-in Ncm	538 380	538 380
Holding Torque Bipolar	oz-in Ncm	680 480	680 480
Detent Torque	oz-in Ncm	18 13	18 13
Rotor Inertia	oz-in-s ² $\times 10^{-4}$ g-cm ²	170 1200	170 1200
Motor Weight (Mass)	lb kg	5.3 2.4	5.3 2.4
Maximum Voltage	V	90	90
Std. No. of Leads	—	8	8

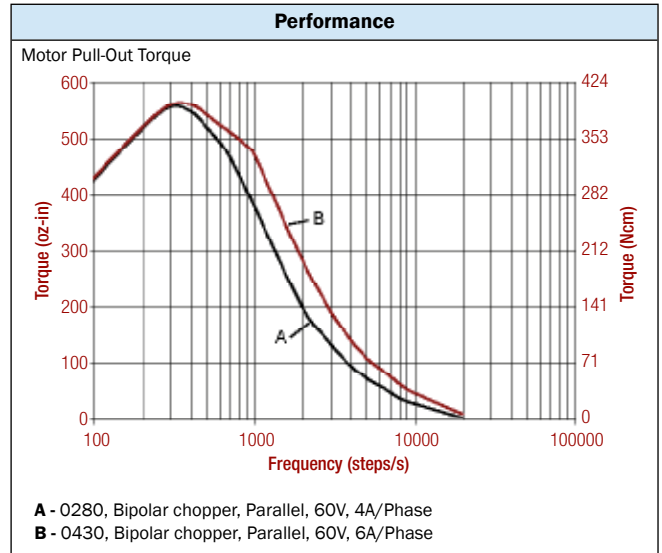

- Standard Features**
- Step angle: 1.8°
 - Step angle accuracy: 5%
 - Insulation class: B (130°C)
 - NEMA 34 mounting configuration
 - Neodymium magnets
 - Additional windings and customization options available

- Complementary Products**
- Gearboxes
 - Encoders

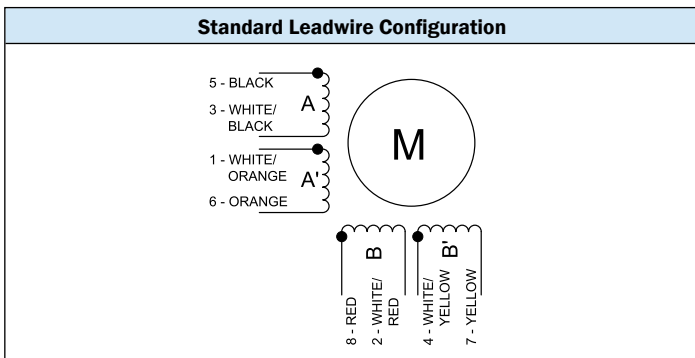

SIZE 34 STEPPER MOTOR DATA

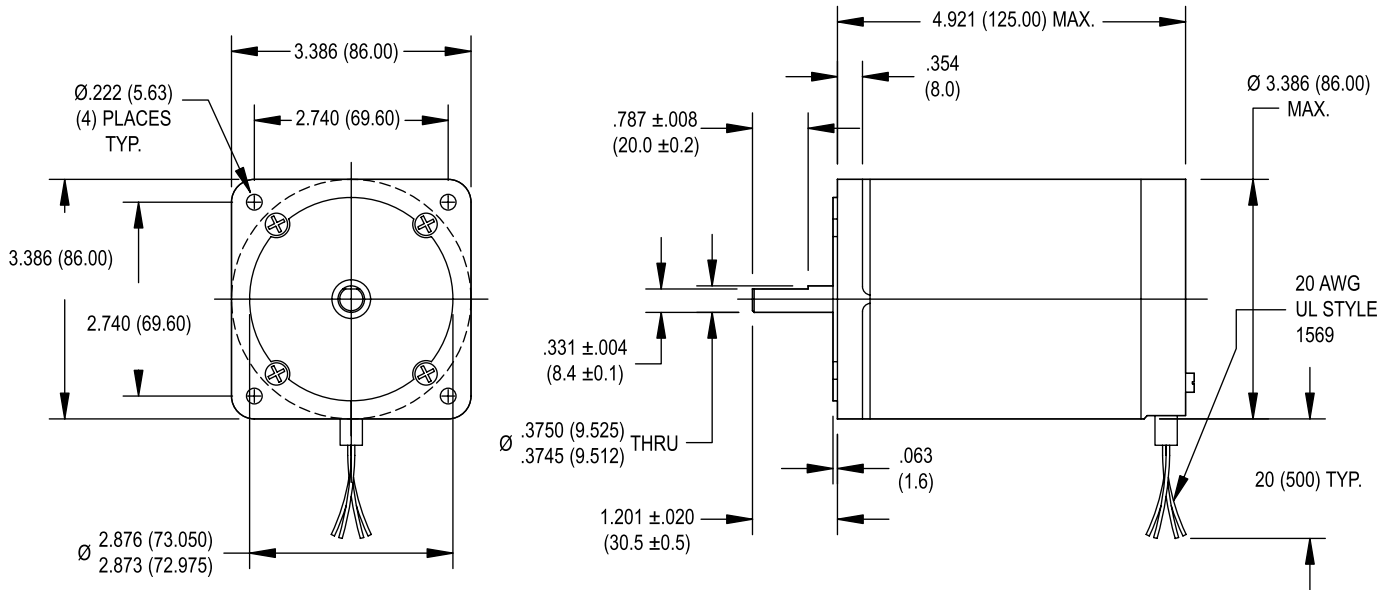

Specification	Units	HN 200 3451	
		0350	0640
Rated Phase Current	A	3.50	6.40
Phase Resistance	Ω	1.5	0.50
Phase Inductance	mH	8.5	2.5
Holding Torque Unipolar	oz-in	878	878
	Ncm	620	620
Holding Torque Bipolar	oz-in	1076	1076
	Ncm	760	760
Detent Torque	oz-in	33	33
	Ncm	23	23
Rotor Inertia	oz-in-s ² x10 ⁻⁴	255	255
	g-cm ²	1800	1800
Motor Weight (Mass)	lb	7.9	7.9
	kg	3.6	3.6
Maximum Voltage	V	140	140
Std. No. of Leads	—	8	8

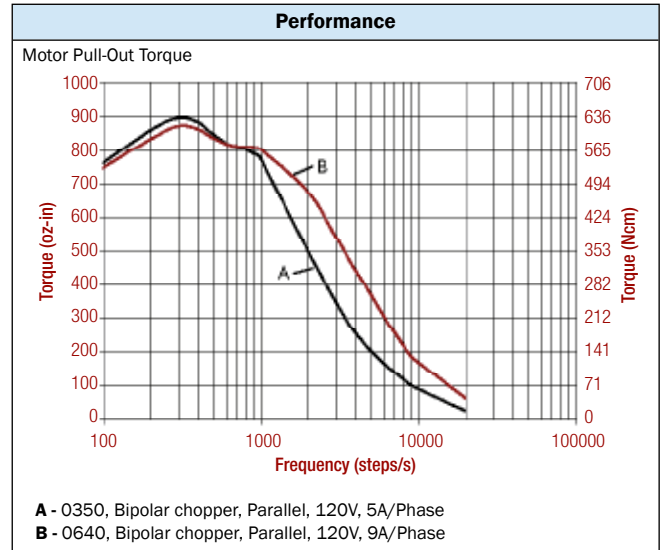

- Standard Features**
- Step angle: 1.8°
 - Step angle accuracy: 5%
 - Insulation class: B (130°C)
 - NEMA 34 mounting configuration
 - Neodymium magnets
 - Additional windings and customization options available

- Complementary Products**
- Gearboxes
 - Encoders

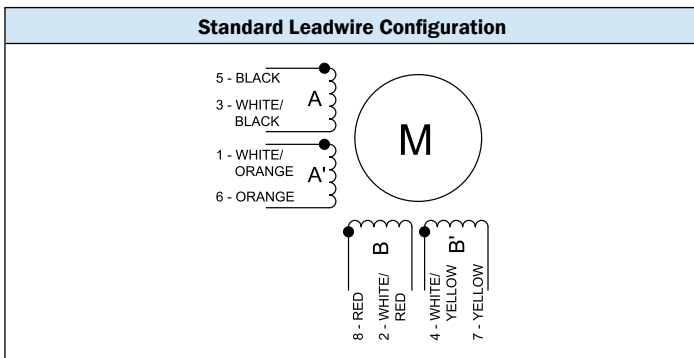

SIZE 34 HIGH PERFORMANCE STEPPER MOTOR DATA

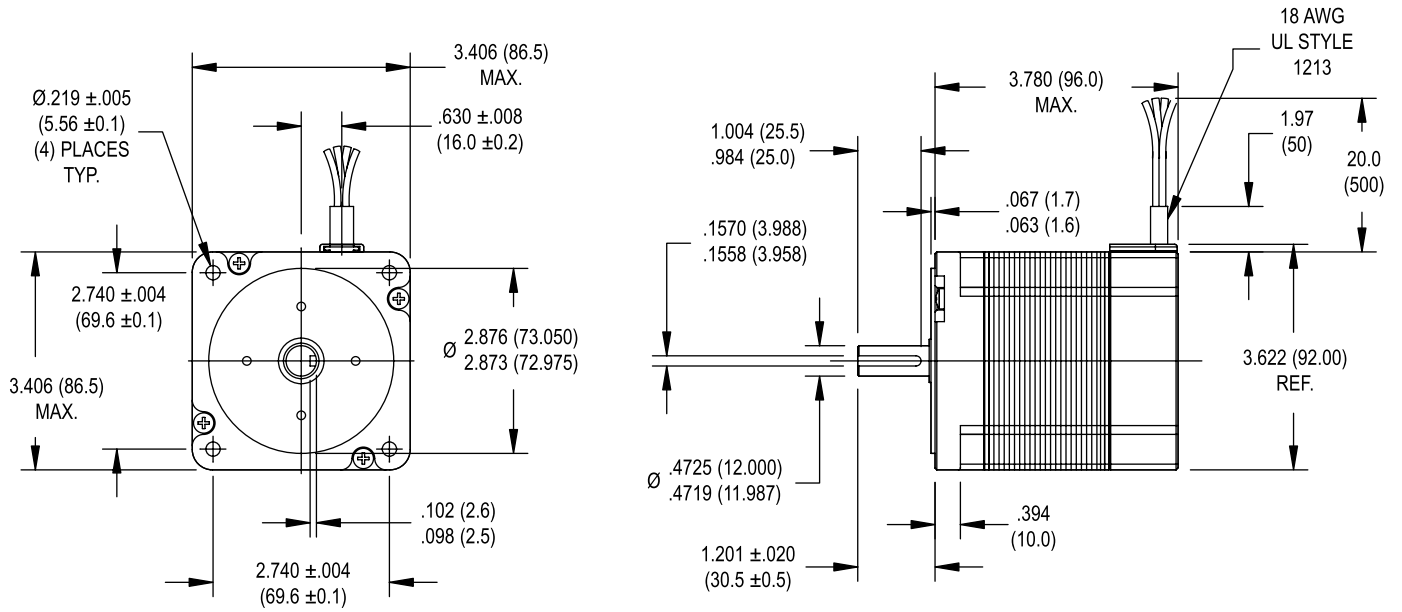

Specification	Units	HS 200 3437		
		0300	0550	0800
Rated Phase Current	A	3.00	5.50	8.00
Phase Resistance	Ω	1.37	0.42	0.19
Phase Inductance	mH	11	3.6	1.6
Holding Torque Unipolar	oz-in Ncm	—	—	—
Holding Torque Bipolar	oz-in Ncm	779 550	779 550	779 550
Detent Torque	oz-in Ncm	28 20	28 20	28 20
Rotor Inertia	oz-in-s ² $\times 10^{-4}$ g-cm ²	490 3460	490 3460	490 3460
Motor Weight (Mass)	lb kg	6.6 3.0	6.6 3.0	6.6 3.0
Maximum Voltage	V	160	160	160
Std. No. of Leads	—	4	4	4

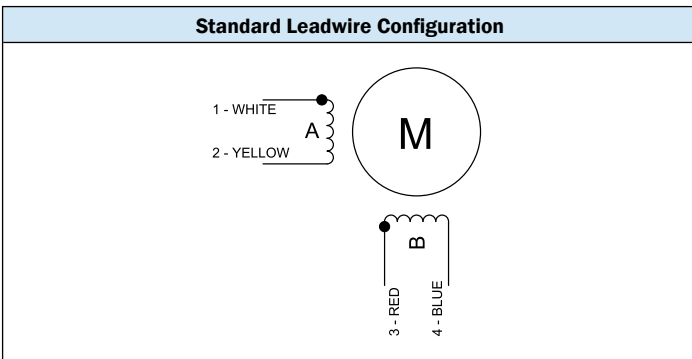
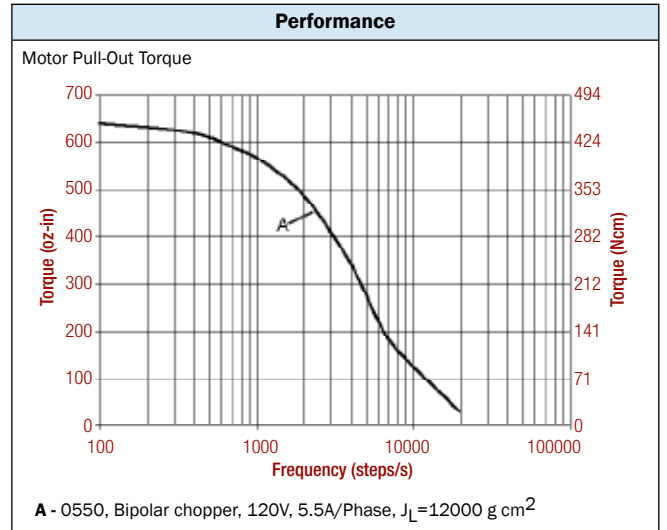

- ### Standard Features
- Step angle: 1.8°
 - Step angle accuracy: 5%
 - Insulation class: B (130° C)
 - Optimized for microstep operation
 - NEMA 34 mounting configuration
 - Neodymium magnets
 - Additional windings and customization options available

- ### Complementary Products
- Gearboxes
 - Encoders

SIZE 34 HIGH PERFORMANCE STEPPER MOTOR DATA

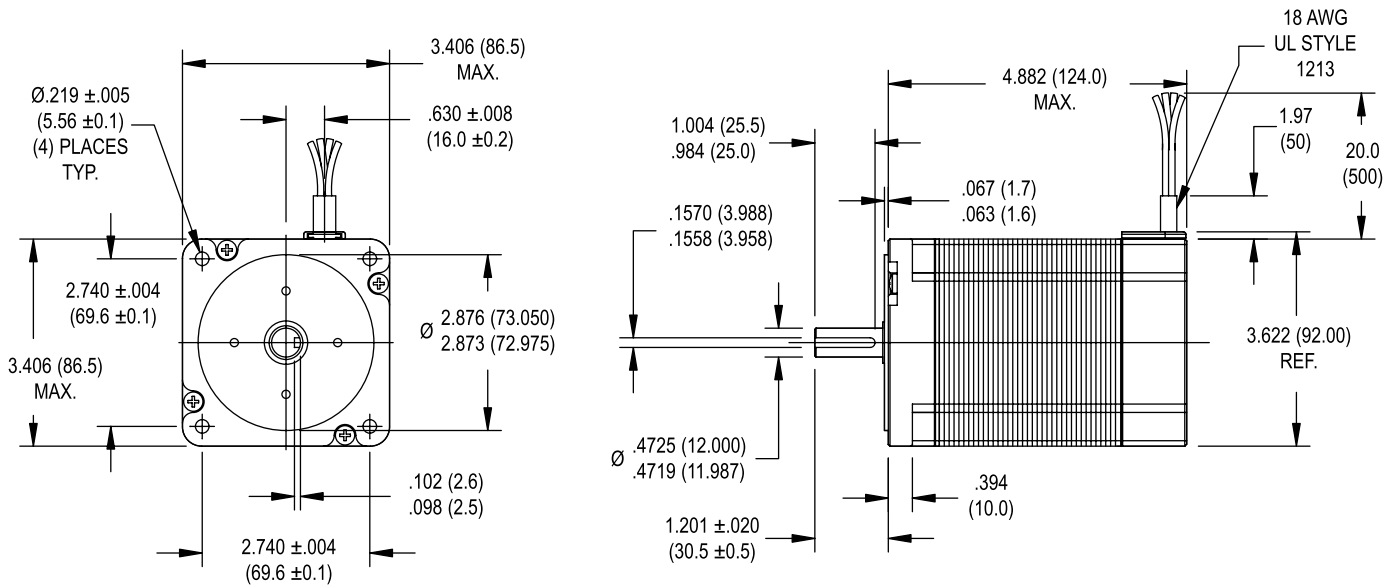

Specification	Units	HS 200 3448		
		0300	0550	0800
Rated Phase Current	A	3.00	5.50	8.00
Phase Resistance	Ω	1.56	0.46	0.22
Phase Inductance	mH	14	4.0	1.9
Holding Torque Unipolar	oz-in	—	—	—
	Ncm	—	—	—
Holding Torque Bipolar	oz-in	1062	1062	1062
	Ncm	750	750	750
Detent Torque	oz-in	28	28	28
	Ncm	20	20	20
Rotor Inertia	oz-in-s ² × 10 ⁻⁴	548	548	548
	g-cm ²	3870	3870	3870
Motor Weight (Mass)	lb	8.8	8.8	8.8
	kg	4.0	4.0	4.0
Maximum Voltage	V	160	160	160
Std. No. of Leads	—	4	4	4

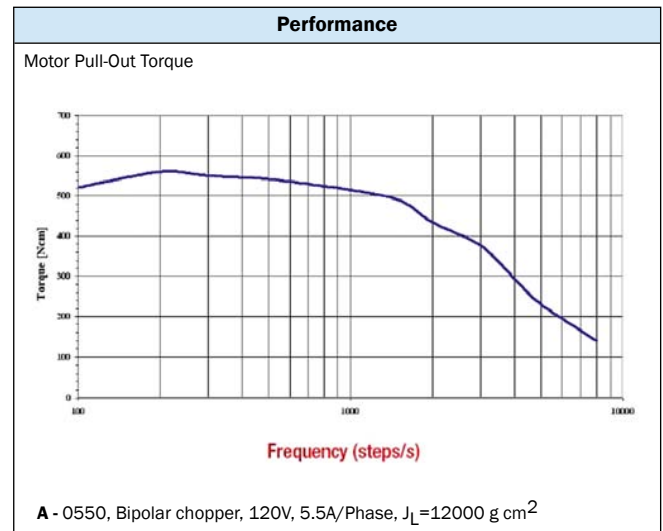

- ### Standard Features
- Step angle: 1.8°
 - Step angle accuracy: 5%
 - Insulation class: B (130°C)
 - Optimized for microstep operation
 - NEMA 34 mounting configuration
 - Neodymium magnets
 - Additional windings and customization options available

- ### Complementary Products
- Gearboxes
 - Encoders

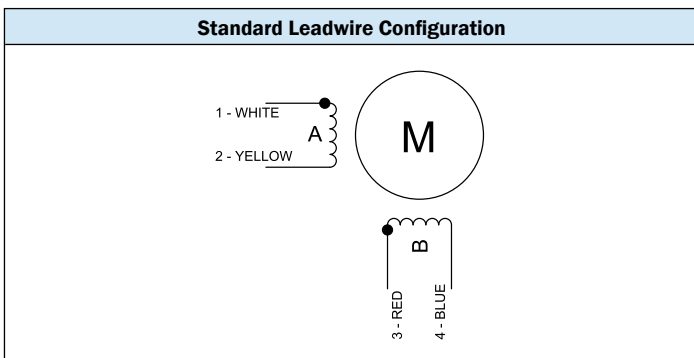

SIZE 34 HIGH PERFORMANCE STEPPER MOTOR DATA

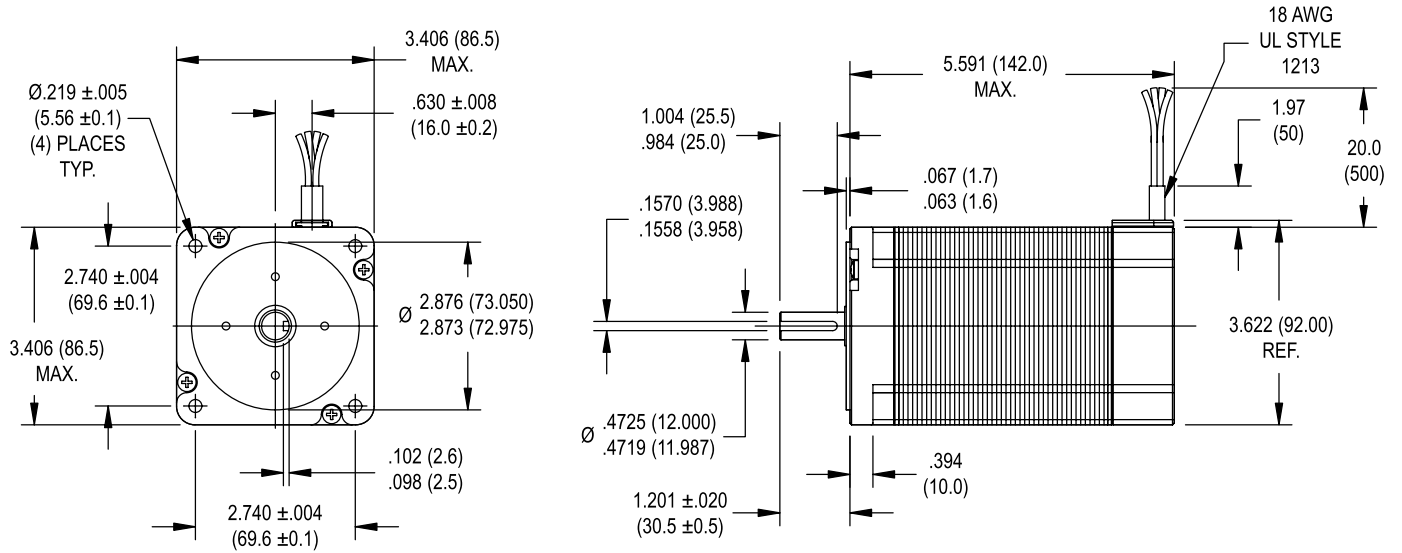

Specification	Units	HS 200 3455		
		0300	0550	0800
Rated Phase Current	A	3.00	5.50	8.00
Phase Resistance	Ω	1.70	0.55	0.29
Phase Inductance	mH	20	5.6	2.6
Holding Torque Unipolar	oz-in Ncm	—	—	—
Holding Torque Bipolar	oz-in Ncm	1416 1000	1416 1000	1416 1000
Detent Torque	oz-in Ncm	42 30	42 30	42 30
Rotor Inertia	oz-in-s ² x10 ⁻⁴ g-cm ²	694 4900	694 4900	694 4900
Motor Weight (Mass)	lb kg	10.8 4.9	10.8 4.9	10.8 4.9
Maximum Voltage	V	160	160	160
Std. No. of Leads	—	4	4	4

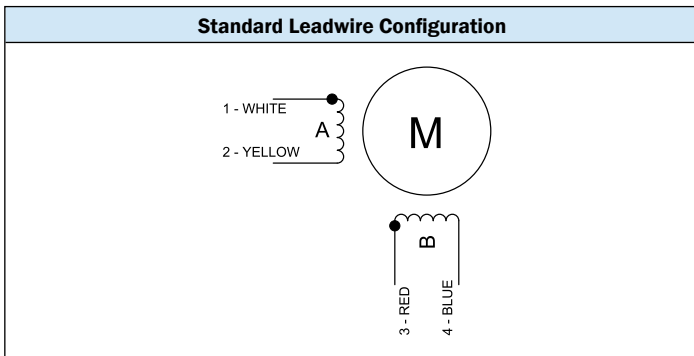
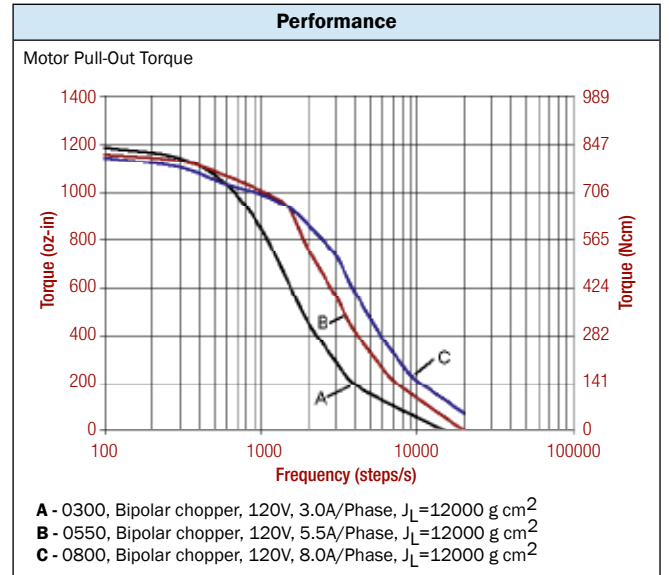

- Standard Features**
- Step angle: 1.8°
 - Step angle accuracy: 5%
 - Insulation class: B (130° C)
 - Optimized for microstep operation
 - NEMA 34 mounting configuration
 - Neodymium magnets
 - Additional windings and customization options available

- Complementary Products**
- Gearboxes
 - Encoders

SIZE 34 HIGH PERFORMANCE STEPPER MOTOR DATA

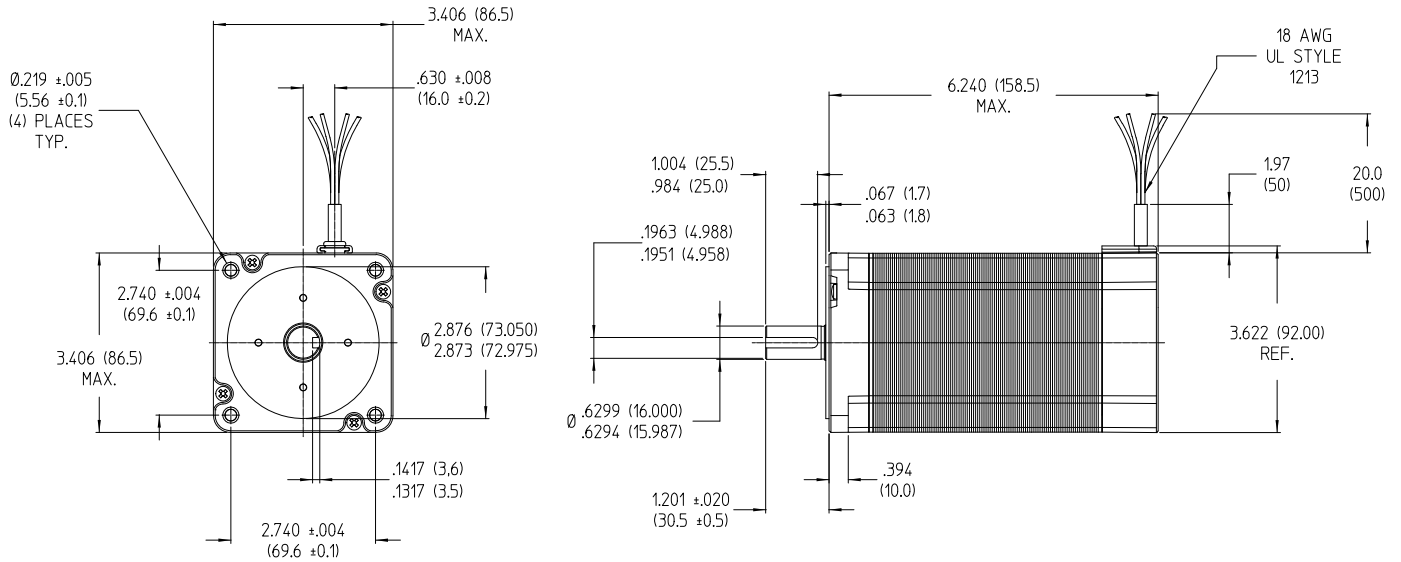

Specification	Units	HS 200 3462	
		0800	
Rated Phase Current	A	8.00	
Phase Resistance	Ω	0.33	
Phase Inductance	mH	2.88	
Holding Torque Unipolar	oz-in	—	
	Ncm	—	
Holding Torque Bipolar	oz-in	1699	
	Ncm	1200	
Detent Torque	oz-in	49	
	Ncm	35	
Rotor Inertia	oz-in-s ² $\times 10^{-4}$	490	
	g-cm ²	8269	
Motor Weight (Mass)	lb	11.9	
	kg	5.4	
Maximum Voltage	V	160	
Std. No. of Leads	—	4	

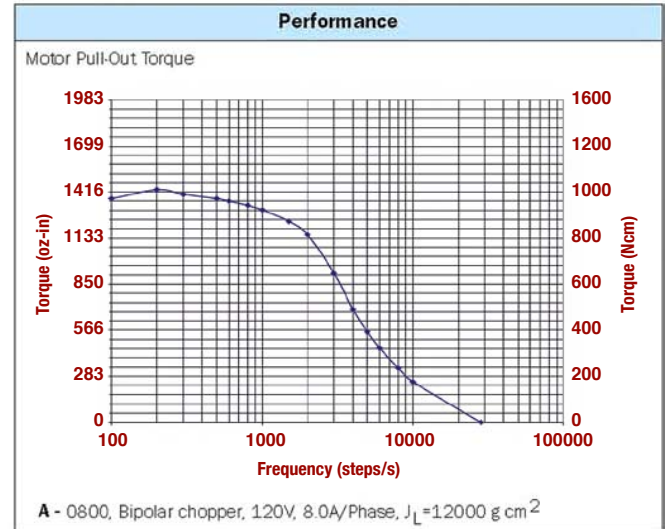

- ### Standard Features
- Step angle: 1.8°
 - Step angle accuracy: 5%
 - Insulation class: B (130°C)
 - Optimized for microstep operation
 - NEMA 34 mounting configuration
 - Neodymium magnets
 - Additional windings and customization options available

- ### Complementary Products
- Gearboxes
 - Encoders

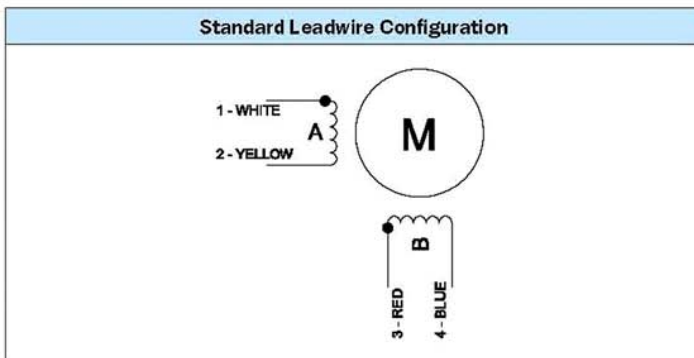

SIZE 34 SYNCHRONOUS MOTOR DATA

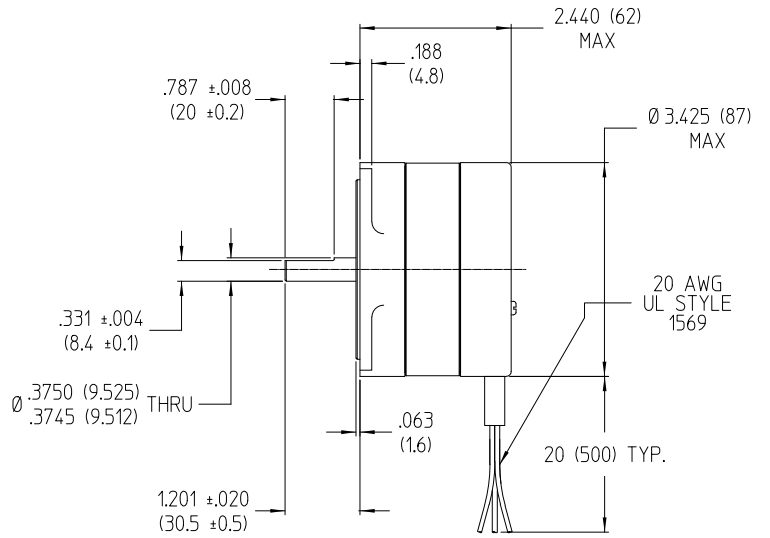
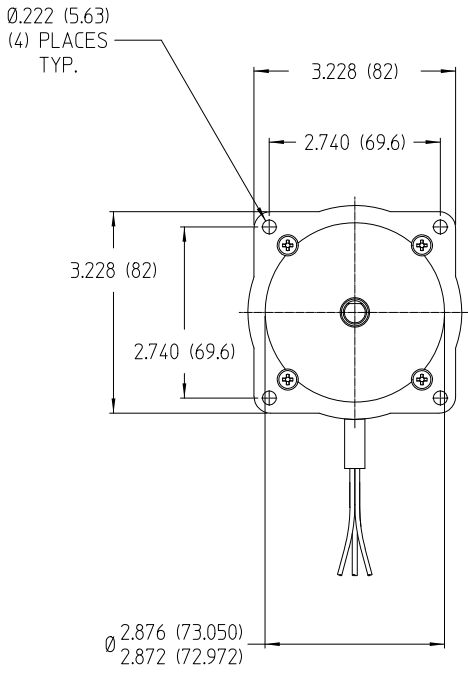

Specifications	Units	SY 3424			
		0110		0240	
Frequency	Hz	50	60	50	60
Velocity	RPM	60	72	60	72
Voltage	V	220	220	120	120
Rated phase Current	A	0,11	0,11	0,24	0,24
Synchronous Torque	oz-in	141	141	141	141
	Ncm	100	100	100	100
Resistor	Ω	750	910	270	470
	W	25	25	25	25
Capacitor	μF	0,80	0,62	2,5	2,0
	V	400	400	250	250
Motor Weight (Mass)	Kg	1,3			
Std. No of Leads		3			

Standard Features
<ul style="list-style-type: none"> • Insulation class: B (130 °C) • Optimized for microstep operation • NEMA 34 mounting configuration
<ul style="list-style-type: none"> • Additional windings and customization options available

Complementary Products
<ul style="list-style-type: none"> • Gearboxes • Encoders

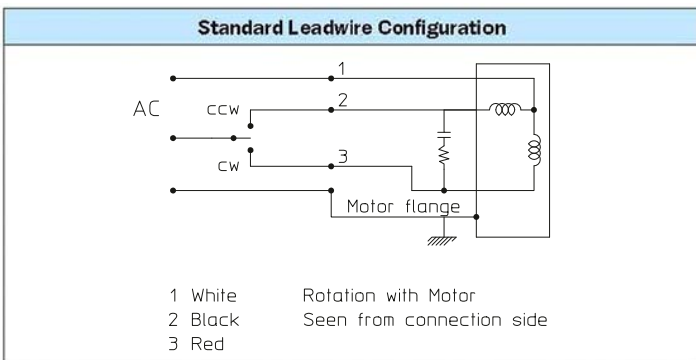

SIZE 34 SYNCHRONOUS MOTOR DATA

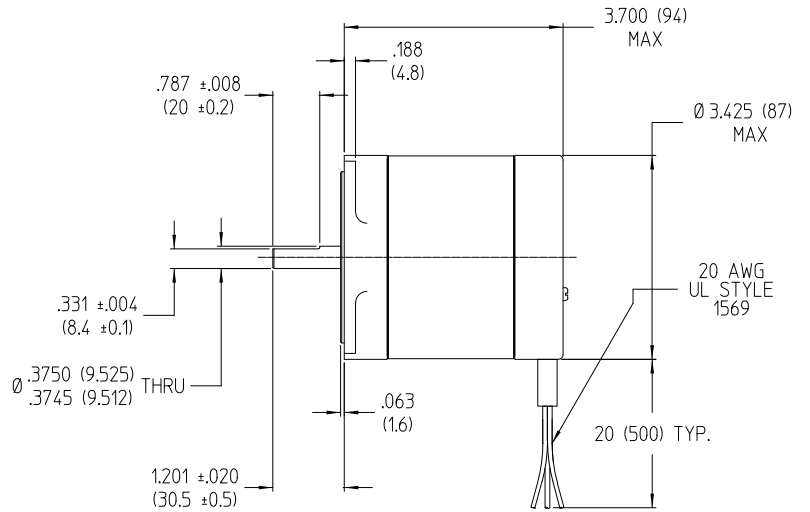
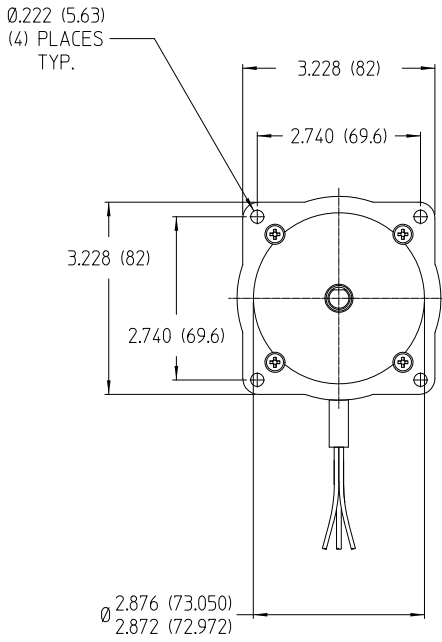

Specifications	Units	SY 3437			
		0240		0450	
Frequency	Hz	50	60	50	60
Velocity	RPM	60	72	60	72
Voltage	V	220	220	120	120
Rated phase Current	A	0,24	0,24	0,45	0,45
Synchronous Torque	oz-in	240	240	240	240
	Ncm	170	170	170	170
Resistor	Ω	820	820	300	300
	W	50	50	50	50
Capacitor	μF	1,60	1,25	6,3	4,0
	V	400	400	250	250
Motor Weight (Mass)	Kg	2,4			
Std. No of Leads		3			

Standard Features
<ul style="list-style-type: none"> • Insulation class: B (130 °C) • Optimized for microstep operation • NEMA 34 mounting configuration
<ul style="list-style-type: none"> • Additional windings and customization options available

Complementary Products
<ul style="list-style-type: none"> • Gearboxes • Encoders

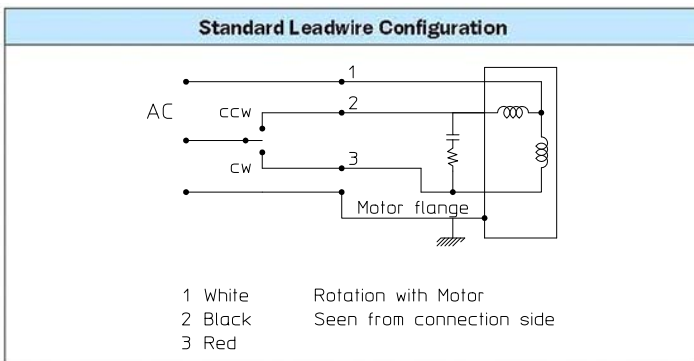

SIZE 34 SYNCHRONOUS MOTOR DATA

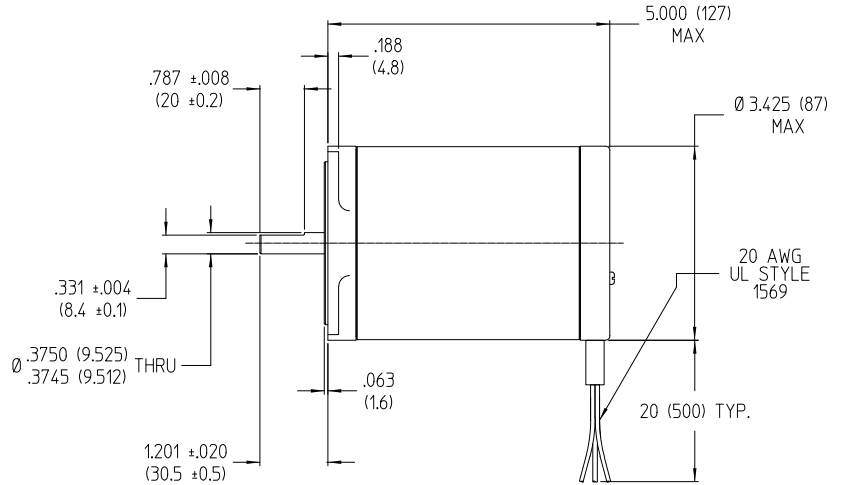
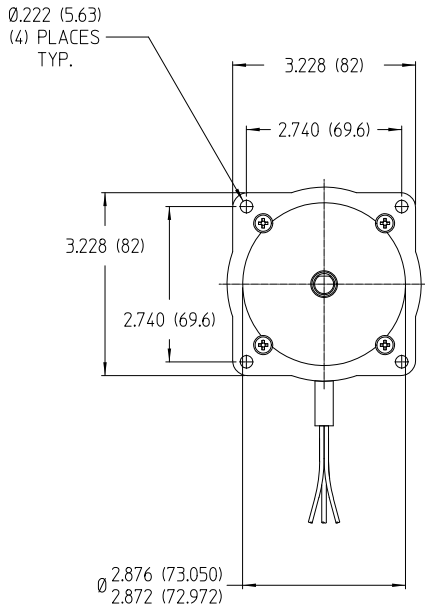

Specifications	Units	SY 3450			
		0350		0600	
Frequency	Hz	50	60	50	60
Velocity	RPM	60	72	60	72
Voltage	V	220	220	120	120
Rated phase Current	A	0,35	0,35	0,6	0,6
Synchronous Torque	oz-in	354	354	354	354
	Ncm	250	250	250	250
Resistor	Ω	560	680	200	200
	W	50	50	100	100
Capacitor	μF	2,5	1,75	8,0	6,5
	V	400	400	250	250
Motor Weight (Mass)	Kg	3,1			
Std. No of Leads		3			

Standard Features
<ul style="list-style-type: none"> Insulation class: B (130 °C) Optimized for microstep operation NEMA 34 mounting configuration
<ul style="list-style-type: none"> Additional windings and customization options available

Complementary Products
<ul style="list-style-type: none"> Gearboxes Encoders

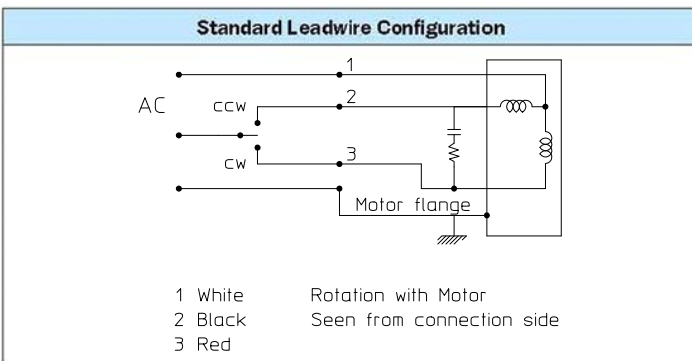

SIZE 42 STEPPER MOTOR DATA

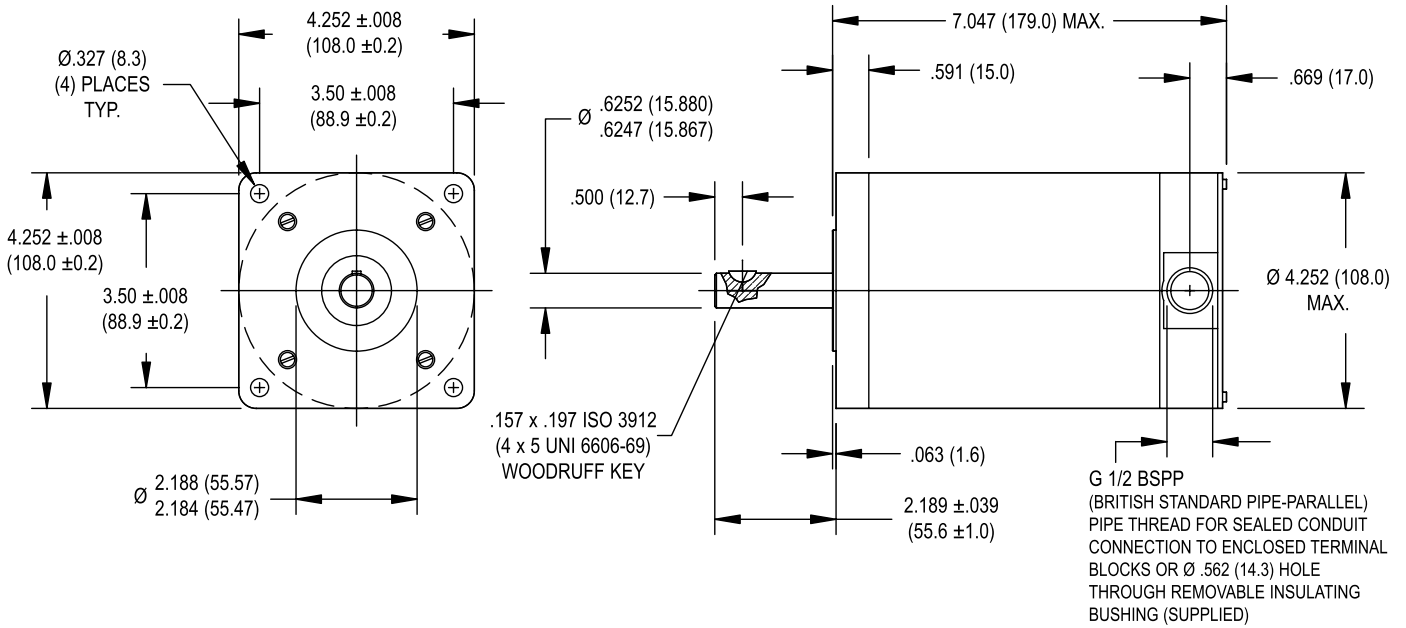

Specification	Units	HY 200 4270		
		0340	0710	0900
Rated Phase Current	A	3.40	7.10	9.00
Phase Resistance	Ω	1.1	0.30	0.34
Phase Inductance	mH	6.3	2.0	2.7
Holding Torque Unipolar	oz-in Ncm	1130 798	1175 830	1450 1024
Holding Torque Bipolar	oz-in Ncm	1402 990	1459 1030	1798 1270
Detent Torque	oz-in Ncm	99 70	99 70	99 70
Rotor Inertia	oz-in-s ² $\times 10^{-4}$ g-cm ²	779 5500	779 5500	779 5500
Motor Weight (Mass)	lb kg	16 7.3	16 7.3	16 7.3
Maximum Voltage	V	140	140	140
Std. No. of Leads	—	8	8	8

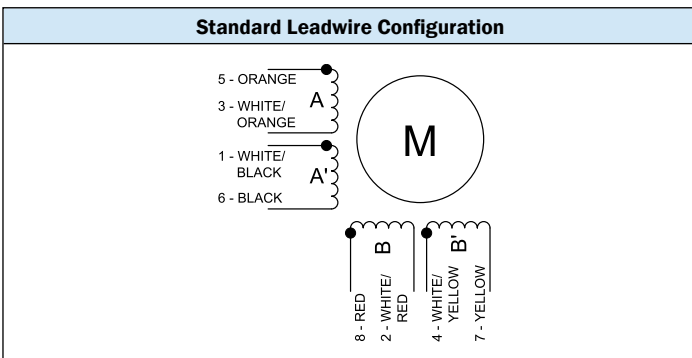
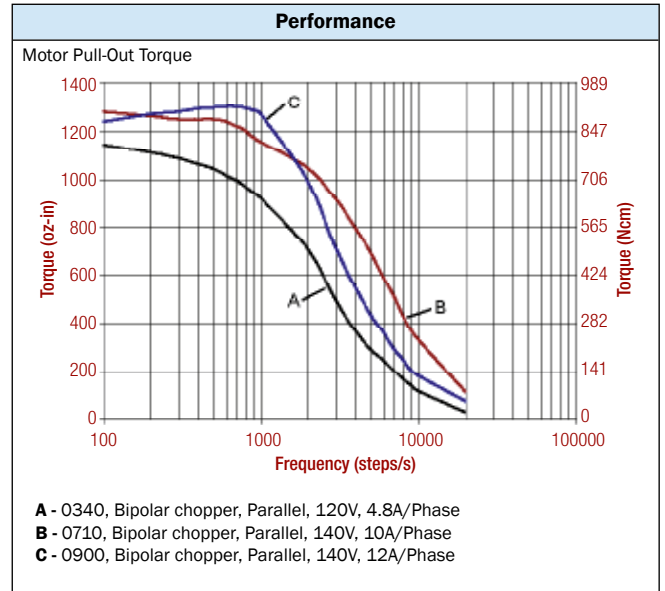

- Standard Features**
- Step angle: 1.8°
 - Step angle accuracy: 5%
 - Insulation class: B (130°C)
 - NEMA 42 mounting configuration
 - AlNiCo magnets
 - Additional windings and customization options available

- Complementary Products**
- Gearboxes
 - Encoders

SIZE 42 STEPPER MOTOR DATA

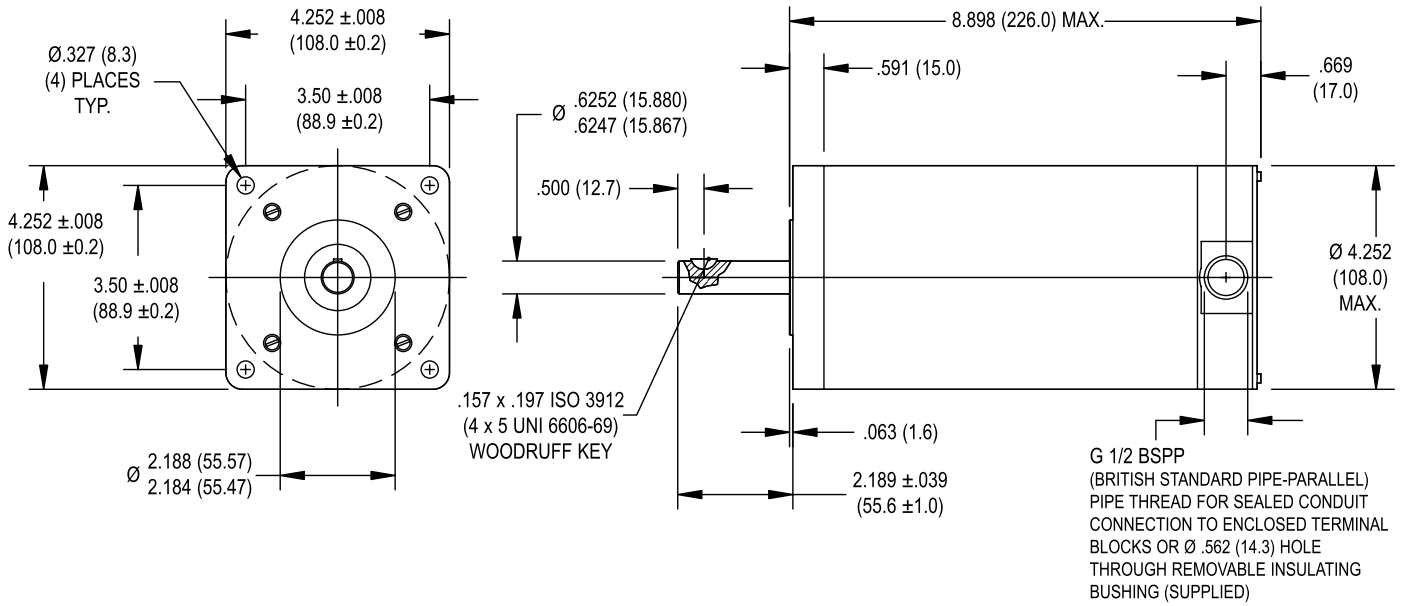

Specification	Units	HY 200 4288	
		0890	
Rated Phase Current	A	8.90	
Phase Resistance	Ω	0.31	
Phase Inductance	mH	2.3	
Holding Torque Unipolar	oz-in	1614	
	Ncm	1140	
Holding Torque Bipolar	oz-in	2018	
	Ncm	1425	
Detent Torque	oz-in	92	
	Ncm	65	
Rotor Inertia	oz-in-s ² $\times 10^{-4}$	1175	
	g-cm ²	8300	
Motor Weight (Mass)	lb	23	
	kg	10.5	
Maximum Voltage	V	140	
Std. No. of Leads	—	8	

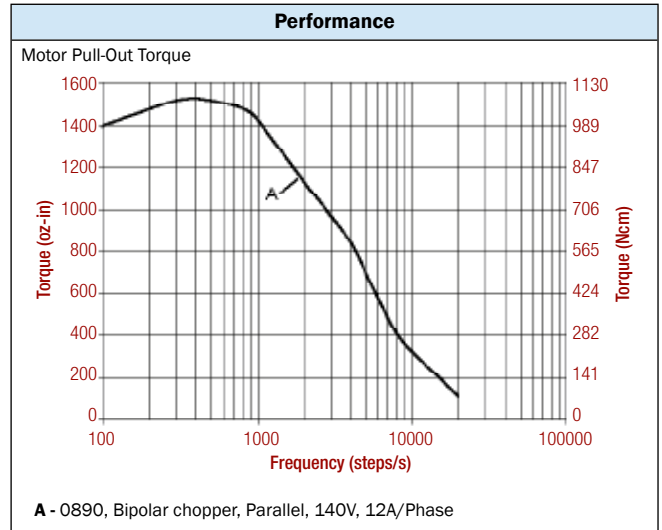

- ### Standard Features
- Step angle: 1.8°
 - Step angle accuracy: 5%
 - Insulation class: B (130°C)
 - NEMA 42 mounting configuration
 - AlNiCo magnets
 - Additional windings and customization options available

- ### Complementary Products
- Gearboxes
 - Encoders

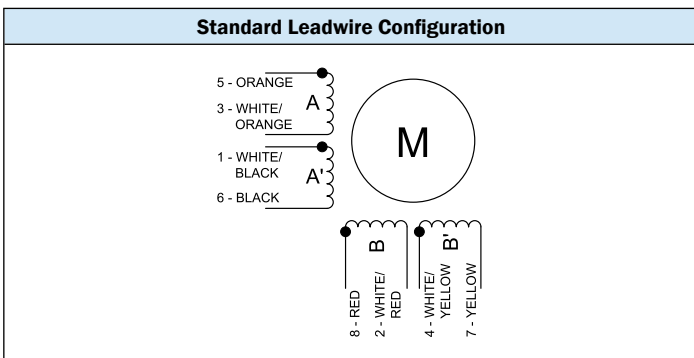

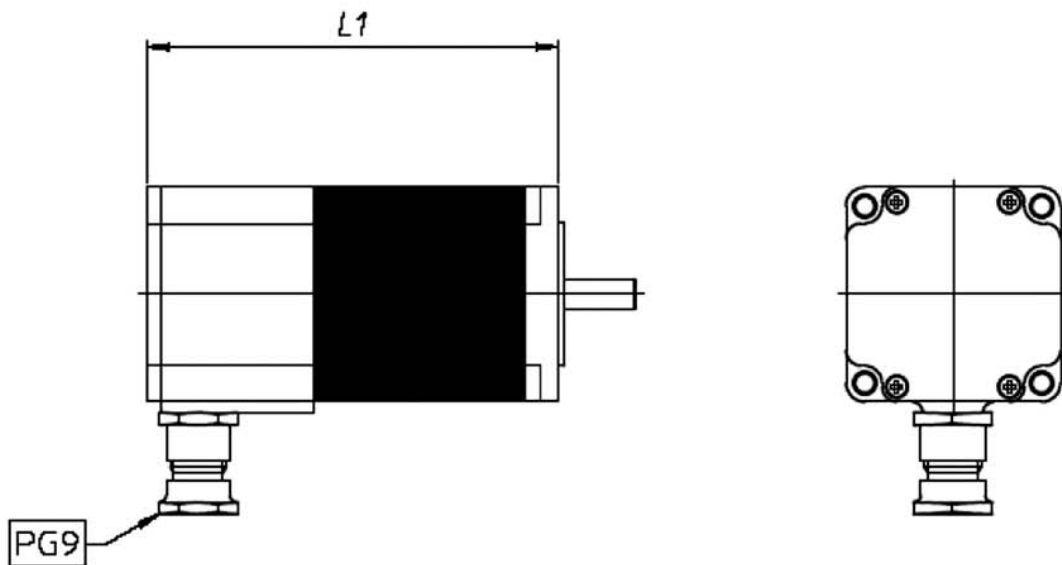
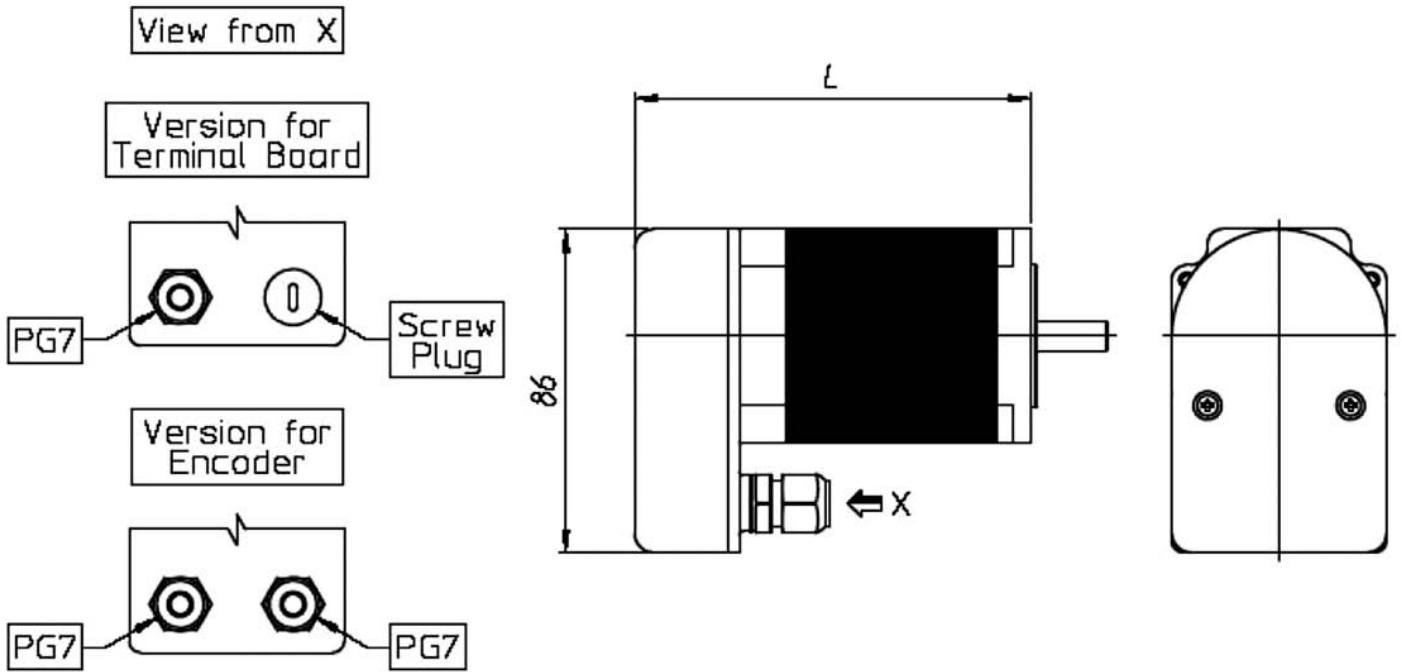

Size	L max
HS200 2216	69,00 mm
HS200 2221	83,00 mm
HS200 2231	107,00 mm

Size	L1 max
HS200 2216	74,00 mm
HS200 2221	88,00 mm
HS200 2231	111,00 mm

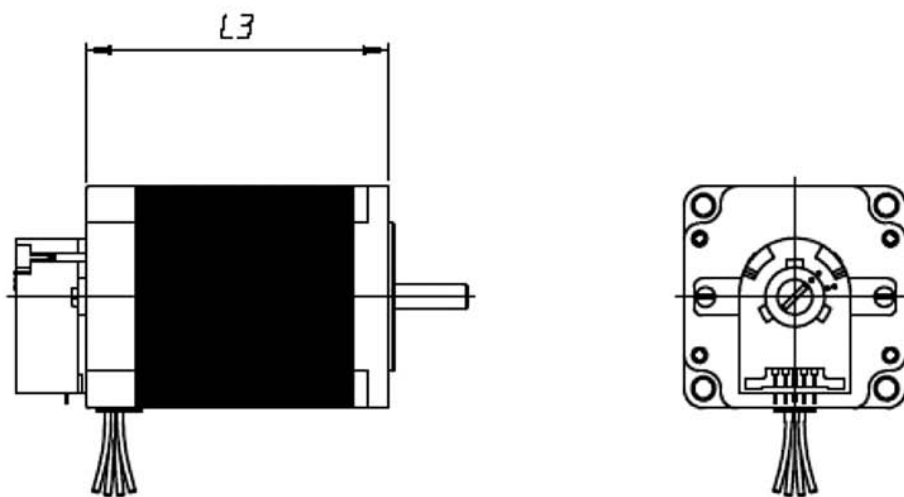
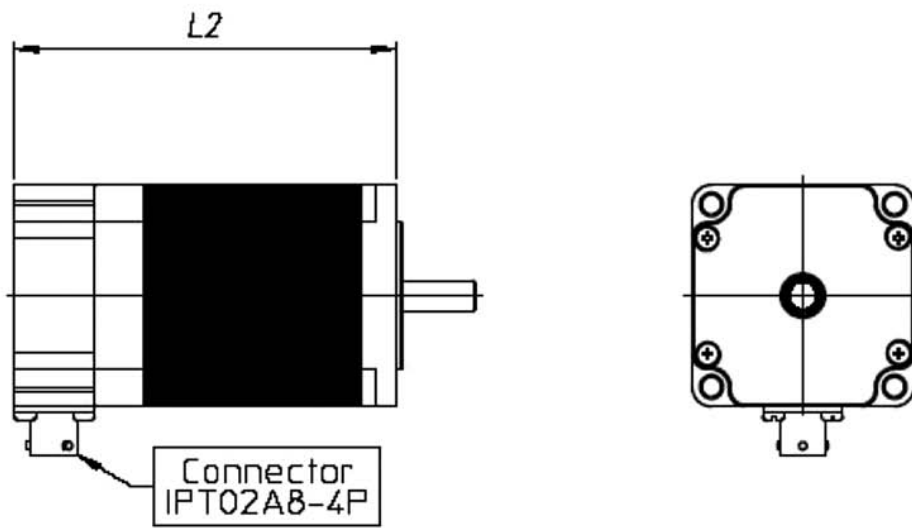

Size	L2 max
HS200 2216	62,00 mm
HS200 2221	76,00 mm
HS200 2231	99,00 mm

Size	L3 max
HS200 2216	41,00 mm
HS200 2221	55,00 mm
HS200 2231	78,50 mm

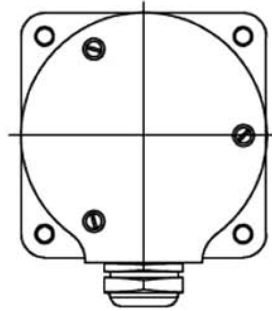
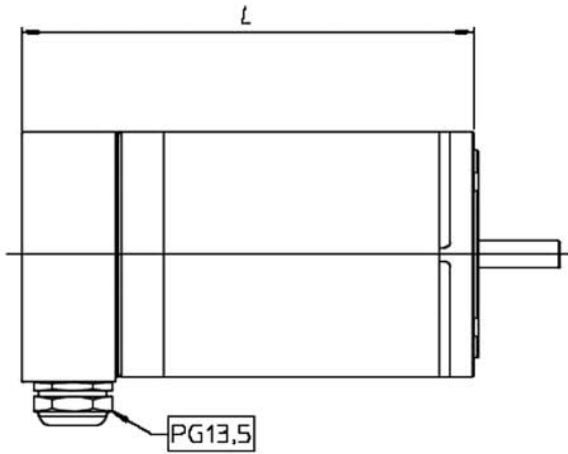

Size	L max
HN200 3426	101,10 mm
HN200 3438	128,10 mm
HN200 3451	159,10 mm

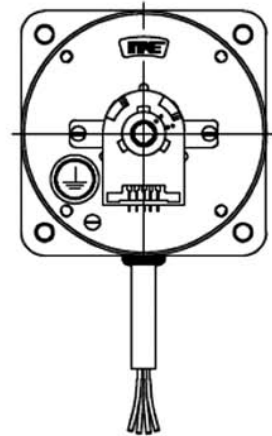
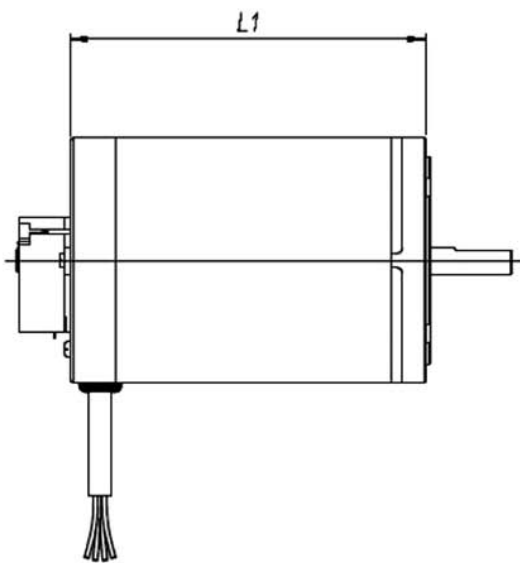

Size	L1 max
HN200 3426	67,00 mm
HN200 3438	94,00 mm
HN200 3451	125,00 mm

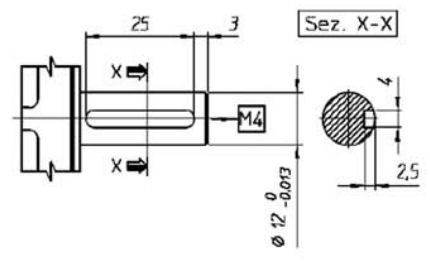
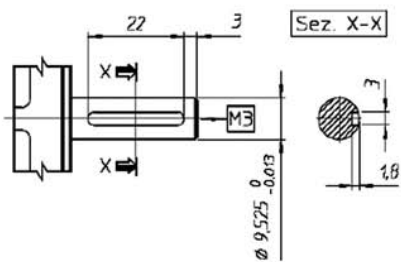
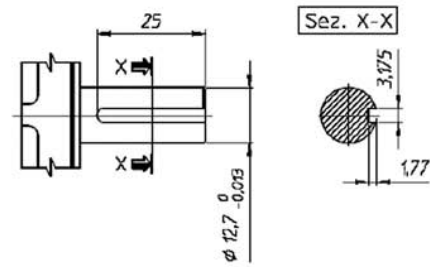
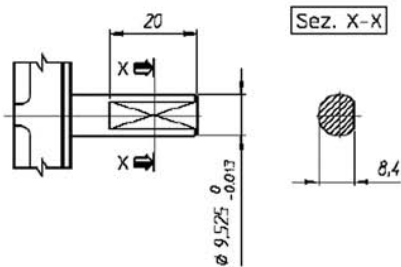

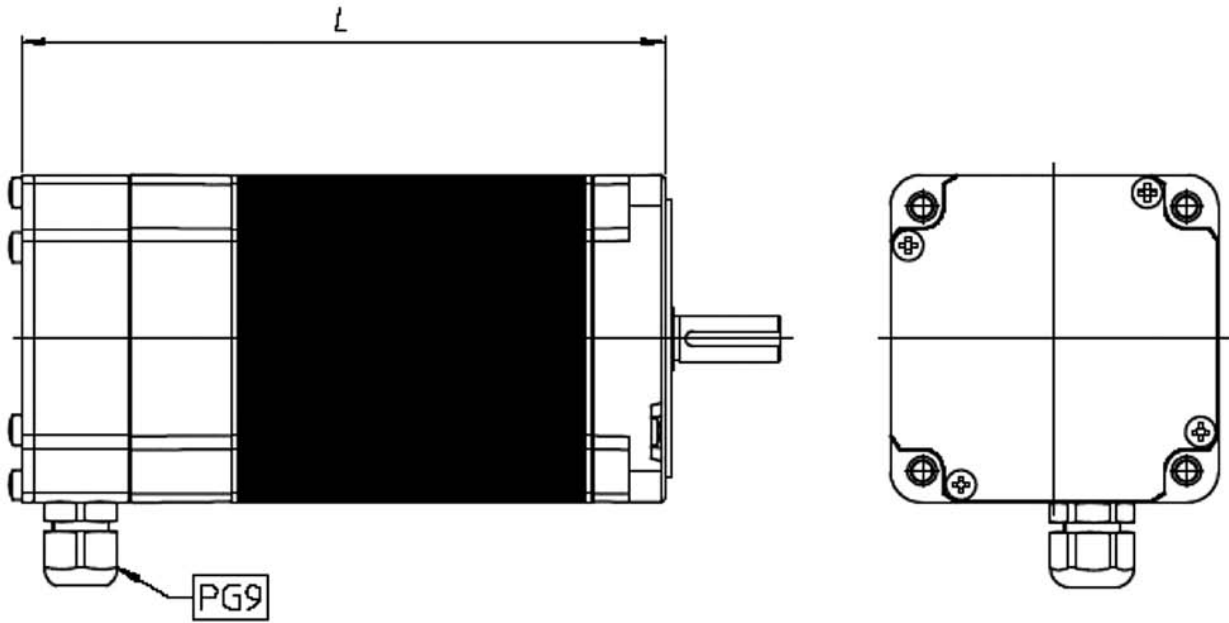

Size	L max
HS200 3437	125,00 mm
HS200 3448	153,00 mm
HS200 3455	171,00 mm

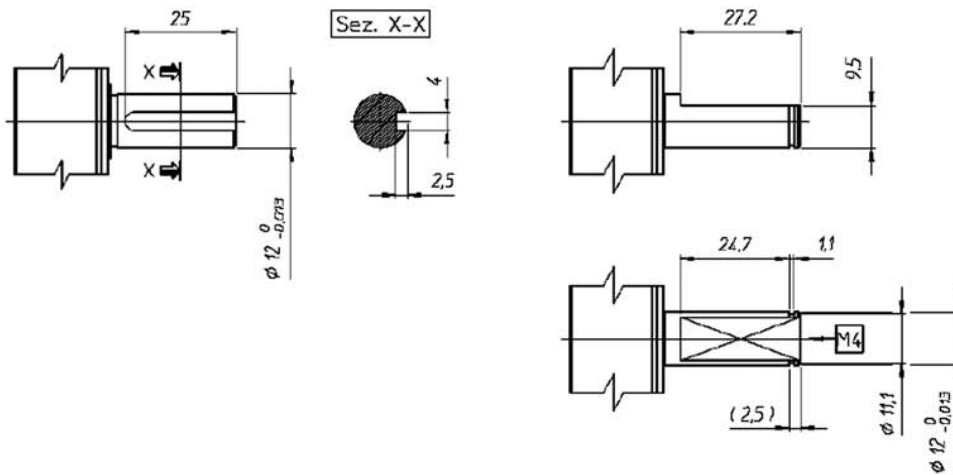

CONNECTION DIAGRAMS

BIPOLAR

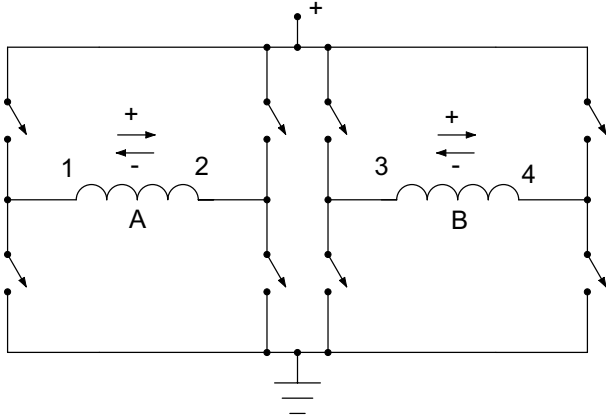

UNIPOLAR

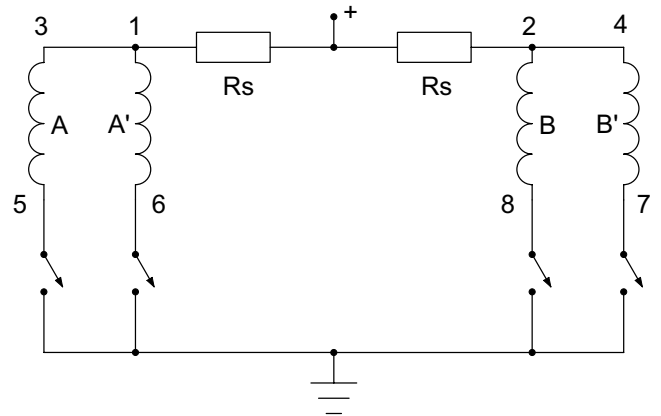

BIPOLAR (PARALLEL)

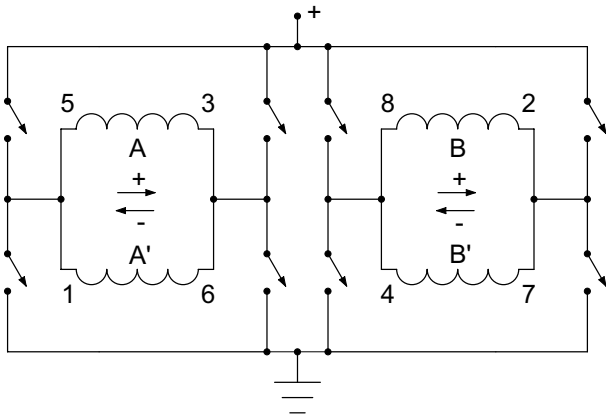

BIPOLAR (SERIES)

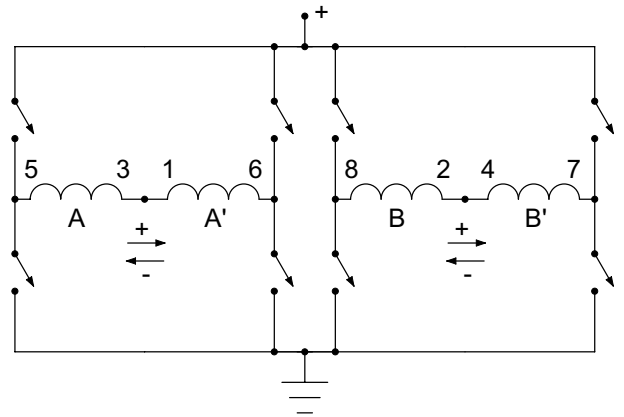

STEP SEQUENCES

FULL STEP OPERATION

HALF STEP OPERATION

One Phase On						
Unipolar				Bipolar		
	A	A'	B	B'		
1	+	0	0	0	1	0 +
2	0	0	+	0	2	- 0
3	0	+	0	0	3	0 -
4	0	0	0	+	4	+ 0
1	+	0	0	0	1	0 +

Two Phases On						
Unipolar				Bipolar		
	A	A'	B	B'		
1	+	0	0	+	1	+ -
2	+	0	+	0	2	+ +
3	0	+	+	0	3	- +
4	0	+	0	+	4	- -
1	+	0	0	+	1	+ -

	Unipolar				Bipolar	
	A	A'	B	B'	A	B
1	+	0	0	+	1	+ +
2	+	0	0	0	2	0 +
3	+	0	+	0	3	- +
4	0	0	+	0	4	- 0
5	0	+	+	0	5	- -
6	0	+	0	0	6	0 -
7	0	+	0	+	7	+ -
8	0	0	0	+	8	+ 0
1	+	0	0	+	1	+ +

NOTE: Following the above steps in sequential order results in clockwise rotation of the shaft when viewed from the mounting end. Reversing the sequence results in counter-clockwise rotation.

Marketing & Engineering:

Ametek Italia S.r.l.
Via de Gasperi 18/a
26010 Ripalta Cremasca (CR)
Italy

Tel.: +39 0373 210247
Fax: +39 0373 210295
e-mail: infosteppers@ametek.it
www.ametekfsm.com

Production & Sales:

Ametek elektromotory s.r.o.
Beloveska 318
547 01 Nachod, Czech Republic

Tel.: +420-494-943041
Fax: +420-494-943049
Mobile +420-602-499677
e-mail: infosteppers@ametek.it
www.ametekfsm.com

MAE STEPPER MOTORS DISTRIBUTORS

Australia & New Zealand:

MOTION SOLUTIONS AUSTRALIA PTY
Ltd.
Factory 2, 21-29 Railway Avenue
Huntingdale, 3166
PH: +613 9563 0115
FAX: +613 9568 4667
www.motion-solutions.com.au

Austria & Hungary:

BURISCH ELEKTRONIK BAUTEILE
GmbH
Burisch Elektronik Bauteile GmbH
Leopoldauer Straße 29
1210 Wien
Tel.: +43-1-277 20-254
Fax: +43-1-277 20-6
www.beb.co.at

Czech Republic:

RAVEO s.r.o.
tř. Tomáše Bati 332
765 02 Otrokovice
Česká republika
Tel: +420 577 663 875
Fax: +420 577 663 875
e-mail: info@raveo.cz

Denmark:

COMPOWER A/S
Smedeholm 13/A
2730 Herlev
Denmark
Phone +45 44 92 66 20
Direct +45 44 50 83 61
Fax +45 44 92 66 02
Mob. +45 26 70 40 82

Finland & Russia:

WEXON O
Juhanilantie 4
FI-01740 Vantaa
Finland
Tel. +358 9 290 44145 (Direct)
Tel. +358 9 290 440
Fax: +358 9 290 44100
www.wexon.com

France:

SODIMATEL
Z.I les Amadiers
11,rue des Entrepreneurs – B.P. 168
78421 CARRIERES SUR SEINE CEDEX
France
Tél : +33 (0) 1 39.13.07.70
Fax : +33 (0) 1 39.14.42.87
www.sodimatel.com

Germany:

ROSIER s.a.
13, rue Sigmund FREUD
69120 VAULX-EN-VELIN
Tél: 04 72 04 68 61
Fax : 04 72 04 37 38
www.rosier.fr

Germany:

AHS ANTRIBSTECHNIK GmbH
Fichtenweg 17
64319 Pfungstadt
Tel.: +49 (0) 6157-9866110
Fax: +49 (0) 6157-9866112
www.ahs-antriebstechnik.de

Israel:

Abiry Technologies Ltd.
17 Hamefalsim St. P.O.B 3265
Petah Tikva 49130
Tel.: +972-3-647 0471
Fax: +972-3-647 0472

Italy:

PAMOCO S.p.A.
Via Riccardo Lombardi, 19/6
20153 Milano
Tel. +39 02 3456091
Fax +39 02 33104342
www.pamoco.it

Netherland & Belgium:

ERIKS bv
Aandrijftechniek Schoonhoven
Broeikweg 25, 2871 RM Schoonhoven
Tel.: +31 (0)182 32 32 38
Fax: +31 (0)182 38 69 20
Mob.: +31 (0)6 539 366 43
www.eriks-at.nl

Singapore:

AXIS CONTROL (S) PTE Ltd.
Block 610 Jurong West Street 65,#08-524
640610 SGP
Singapore
Tel.: +65 6896 8252
Fax: +65 6792 5981
www.axiscontrol.com.sg

Spain:

ELMEQ
C/ Vilamarí, 50 - 08015 Barcelona
Tel: +34 93 292 78 43
Fax: +34 93 432 36 60
www.elmeqmotor.es

United Kingdom:

McLENNAN SERVO SUPPLIES LIMITED
Unit 1, The Royston Centre, Lynchford
Lane
Ash Vale, GU12 5PQ
United Kingdom
Direct Line: +44 (0)8707 700666
Mobile: +44 (0)7887 532124
Main Line: +44 (0)8707 700700
Fax: +44 (0)8707 700699
www.mclennan.co.uk

ASTROSYN INTERNATIONAL TECHNO-
LOGY Ltd.

The Old Courthouse
New Road Avenue
Chatham
Kent, ME4 6BE
Tel: +44 (0) 1634 815175
Fax: +44 (0) 1634 826552
www.astrosyn.com

AMETEK Inc.
is a leading global manufacturer of electronic instruments and electromechanical devices with annualized sales of \$3.4 billions.



AMETEK has approximately 13,300 colleagues working at more than 100 manufacturing facilities and more than 100 sales and service centers in the United States and around the world.