

# TFS3

series



---

## Product Segments

- **Care Motion**
- **Industrial Motion**

---

## General Features

Maximum available buttons	2
IP rating	Up to IP66
Options	with back up battery or cable less control

**Drawing**

Standard Dimensions  
(mm)

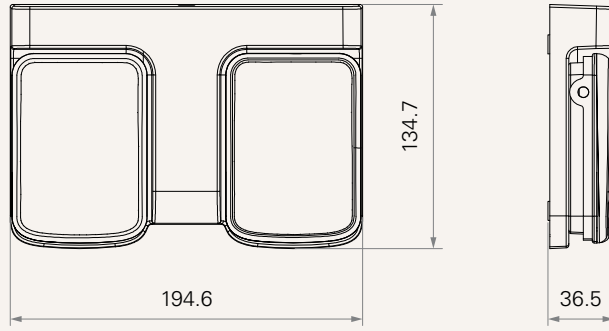

<b>Connection</b>	0 = Wireless (Frequency: 2.4G)		1 = Cable (Straight, 1500mm)
<b>Plug</b>	0 = Without (Wireless version) 1 = DIN 8P, 90° 2 = RJ 10P, 90° 4 = DIN 8P, 180°		5 = RJ 10P, 180° 6 = Flat RJ 10P, 180° 7 = Short DIN 5P 8 = Long DIN 5P
<b>Color</b>	1 = Black 2 = Grey (Pantone 428C)		3 = White upper cover, Pantone 428C for keypad (Standard)
<b>Button Definition</b>	1 = Left key: Extend / Right key: Retract		2 = Left key: Retract / Right key: Extend
<b>Which Motor to Control</b>	1 = 1 2 = 2	3 = 3 4 = 4	5 = 5 6 = 6
<b>Built-in Backup Battery</b>	0 = Without battery shrapnel, without battery 1 = With battery shrapnel, with battery (2*AAA 1.5V dry batteries) 2 = With battery shrapnel, without battery		
<b>IP Rating</b>	0 = Without	1 = IP54	2 = IP66
<b>Control Box Type</b>	0 = Without MCU + Without MCU control box 1 = With MCU + Without MCU control box 2 = Without MCU + With MCU control box		3 = With MCU + With MCU control box D = Direct cut (only supplied by "cable" option in connection section)

### Terms of Use

The user is responsible for determining the suitability of TiMOTION products for a specific application. TiMOTION products are subject to change without prior notice.