

Positioning system ELSZ 30, 40, 60, 60S, 80, 80S, 100, 125

With standard belt

Specifications

3.1

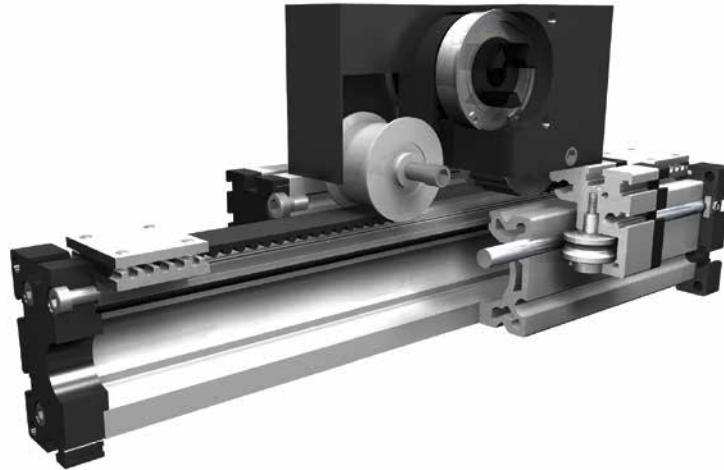

Function:

This linear unit consists of an aluminium square profile with hardened steel guide rods. The carriage, which has internal linear ball bearings that can be adjusted free of play, is driven along the guide rods by a timing belt. The pulley has maintenance-free ball bearings. Belt tension can be readjusted by a simple tensioning device in one of the end blocks. This device can also be used for symmetrical adjustment of two or more linear units running parallel.

Fitting position: As required. Max. length without joints 6.000 mm.

Carriage mounting: By T-slots.

Unit mounting: By T-slots or tapped holes in the bearing blocks, or mounting sets.

Belt type: HTD with steel reinforcement, no backlash when changing direction, repeatability ± 0,1 mm.

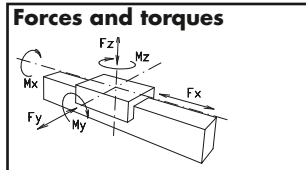

Size	ELSZ 30		ELSZ 40		ELSZ 60		ELSZ 60 S		ELSZ 80		ELSZ 80 S		ELSZ 100		ELSZ 125	
	static	dynam.	static	dynam.	static	dynam.	static	dynam.	static	dynam.	static	dynam.	static	dynam.	static	dynam.
Forces/Torques																
F _x (N)	200	180	390	350	894	800	894	800	1900	1800	1900	1800	4000	3800	5900	5750
F _y (N)	90	60	1200	700	3000	2000	4100	3100	3000	2000	4600	3600	8000	6500	12000	9000
F _z (N)	90	60	900	650	1700	1100	2160	1600	1700	1100	3000	1800	3600	2200	6000	4500
M _x (Nm)	10	5	25	20	67	43	88	65	90	55	170	140	300	230	600	450
M _y (Nm)	13	6	32	18	90	70	190	140	110	80	270	230	400	270	750	600
M _z (Nm)	14	7	35	25	120	100	230	170	150	120	300	220	750	500	1350	1150

All forces and torques relate to the following:
 existing values $\frac{F_y}{F_{y_{dyn}}} + \frac{F_z}{F_{z_{dyn}}} + \frac{M_x}{M_{x_{dyn}}} + \frac{M_y}{M_{y_{dyn}}} + \frac{M_z}{M_{z_{dyn}}} \leq 1$
 table values

No-load torque																
Nm		0,2		0,7		0,9		0,9		1,1		1,2		1,5		1,8
Speed																
(m/s) max		2		4		5		7		6		8		8		10
Tensile force																
permanent (N)		200		390		900		900		1900		1900		4000		5900
0,2 s (N)		280		480		1000		1000		2090		2090		4300		6350
Geometrical moments of inertia of aluminium profile																
I _x mm ⁴		4,09x10 ⁴		1,32x10 ⁵		6,79x10 ⁵		6,79x10 ⁵		18,99x10 ⁵		18,99x10 ⁵		44,4x10 ⁵		101,5x10 ⁵
I _y mm ⁴		4,00x10 ⁴		1,34x10 ⁵		6,97x10 ⁵		6,97x10 ⁵		18,97x10 ⁵		18,97x10 ⁵		44,8x10 ⁵		101,5x10 ⁵
E-Modulus N/mm ²		70000		70000		70000		70000		70000		70000		70000		70000

For life-time calculation of rollers use our homepage.

Driving torque:

$$M_o = \frac{F \cdot P \cdot S_i}{2000 \cdot \pi} + M_n$$

$$P_o = \frac{M_o \cdot n}{9550}$$

- F = force (N)
- P = pulley action perimeter (mm)
- S_i = safety factor 1,2 ... 2
- M_n = no-load torque (Nm)
- n = rpm pulley (min⁻¹)
- M_o = driving torque (Nm)
- P_o = motor power (KW)

Deflection:

$$f = \frac{F \cdot L^3}{E \cdot I \cdot 192}$$

- f = deflection (mm)
- F = load (N)
- L = free length (mm)
- E = elastic modulus 70000 (N/mm²)
- I = second moment of area (mm⁴)

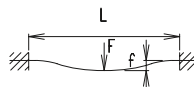

Positioning system ELSZ 30, 40, 60, 60S, 80, 80S, 100, 125

Dimensions (mm)

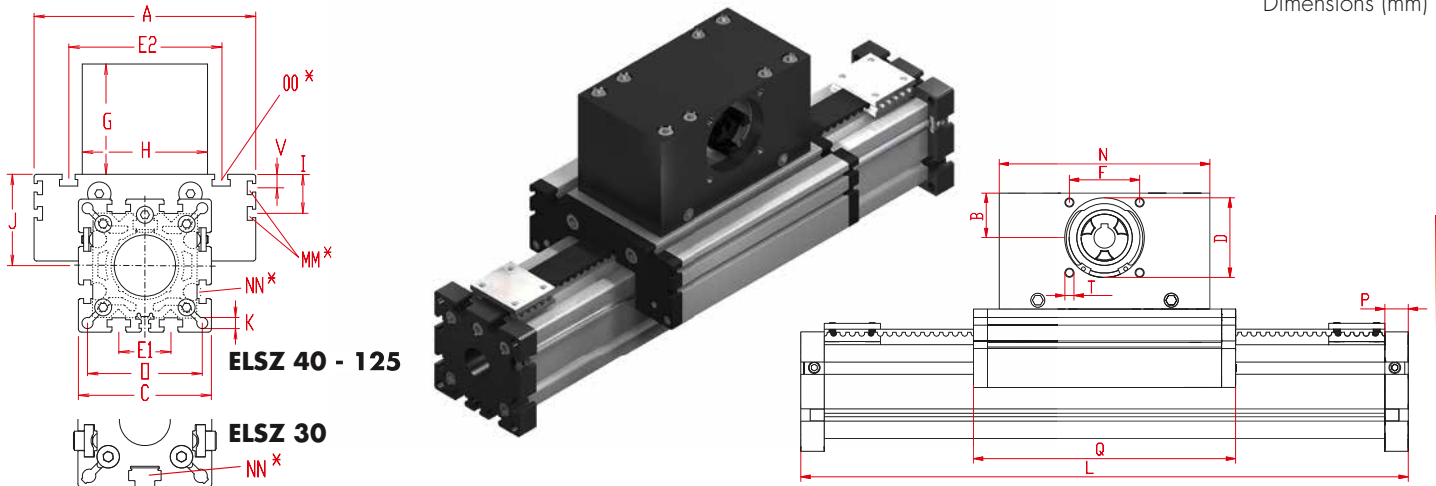

3.1

*For slide nuts refer to chapter 2.2 page 2

Increasing the carriage length will increase the basic length by the same amount.

Size	Basic length L	A	B	C	D -0,05	E1	E2	F	G	H	I	J	K	MM for	N	NN for	O	OO for	P	Q	T	V	Basic weight	Weight per 100 mm
ELSZ 30	182	70	16	42	28	-	56	25	45	42	-	26	4,2	-	90	M 6	35	M 6	12	108	M 4	-	1,33 kg	0,16 kg
ELSZ 40	230	100	20	58	37	25	66	32	65	60	-	35	6,5	-	110	M 6	47	M 6	12	142	M 5	-	2,1 kg	0,24 kg
ELSZ 60	280	144	30	82	47	30	96	42	80	80	-	49	8,5	-	130	M 8	69	M 8	16	168	M 6	-	5,1 kg	0,62 kg
ELSZ 60S	305	170	30	82	47	30	108	42	80	80	-	53	8,5	-	130	M 8	69	M 8	16	194	M 6	-	6,1 kg	0,62 kg
ELSZ 80	365	170	39	102	68	40	117	60	100	100	30	70	8,5	M 6	180	M 10	88	M 10	20	214	M 8	10	11,0 kg	1,00 kg
ELSZ 80S	365	190	39	102	68	40	126	60	100	100	30	71	8,5	M 6	180	M 8	88	M 8	20	214	M 8	12,5	12,0 Kg	1,00 Kg
ELSZ 100	535	230	60	130	90	50	155	80	130	130	29	89	10,5	M 10	270	M 12	112	M 10	30	310	M 10	-	25,8 kg	1,60 kg
ELSZ 125	595	295	62	165	110	60	200	100	139	160	30	107,5	M 10	M 10	310	M 12	140	M 12	30	365	M 10	-	54,5 kg	1,94 kg

0 Choice of guide body profile:

- (0) Standard
- (2) corrosion-protected guide rods and screws
- (4) expanded corrosion-protected version (depending on the availability of components)

0 Choice of carriages:

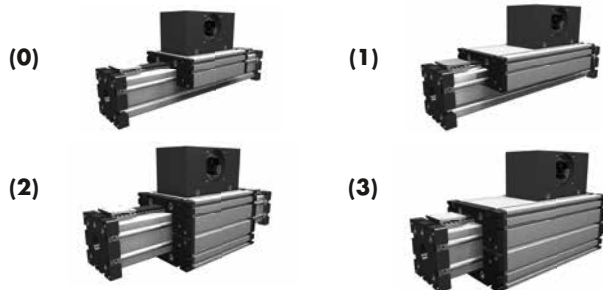

Size	Version 1		Version 2		Version 3	
	Q	L	Q	L	Q	L
30	175	245	124	194	197	267
40	237	325	158	246	253	341
60	303	415	184	296	319	431
60S	329	431	214	325	349	451
80	379	525	230	381	395	541
80S	379	525	234	395	419	565
100	535	760	326	551	551	776
125	640	870	389	619	664	894

0 Drive version:

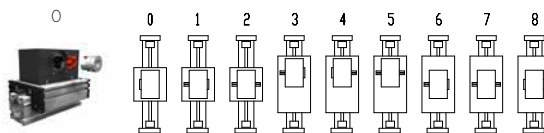

The standard version is supplied without shaft. A shaft can be retrofitted by inserting it into the pulley bore and securing it with 2 locking rings or tension sets (size 100 + 125).

Version 8 is the same as 0, but with double sided coupling claw.

Belt table

Code No.	Size	Belt	mm/rev.	Number of teeth
0 1	30	3M12	75	25
0 3	40	5M15	100	20
0 4	60 (S)	5M25	130	26
0 7	80 (S)	8M30	192	24
0 9	100	8M50	256	32
1 0	125	8M70	304	38

Shaft dimensions / Coupling claw

Size	Shaft ø h6 x length	Key	Coupling
30	6 x 15	2x2x12	7
40	10 x 27	3x3x25	9
60 (S)	14 x 35	5x5x28	14
80 (S)	18 x 45	6x6x40	19
100	22 x 45	6x6x40	24
125	30 x 55	8x7x50	28

Basic length + stroke = total length

ELSZ 60 0 0 0 0 0 4 1 01500

For combination kits and connecting elements refer to chapter 2.2

Pos. 1 2 3 4 5 6 7

Sample ordering code:

ELSZ 60 with standard body profile, standard carriage and coupling claw on one side, 1220 mm stroke.



Positioning system ELSZ 30, 40, 60, 60S, 80, 80S, 100, 125

With widened belt drive

Specifications

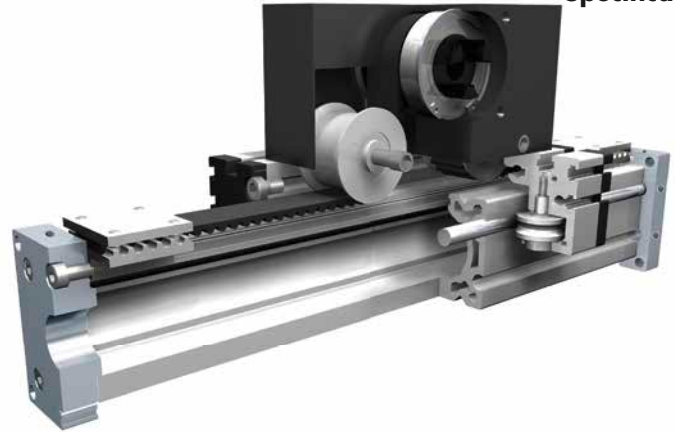

3.1

Function:

This linear unit consists of an aluminium square profile with hardened steel guide rods. The carriage, which has internal linear ball bearings that can be adjusted free of play, is driven along the guide rods by a timing belt. The pulley has maintenance-free ball bearings. Belt tension can be readjusted by a simple tensioning device in one of the end blocks. This device can also be used for symmetrical adjustment of two or more linear units running parallel.

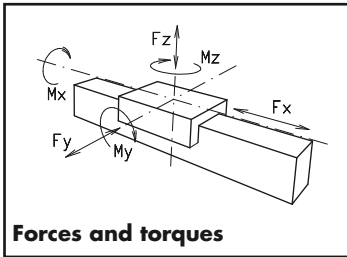

Fitting position:
Carriage mounting:
Unit mounting:
Belt type:

As required. Max. length without joints 6.000 mm.
 By T-slots.
 By T-slots, threads or tapped holes in the bearing blocks, or mounting sets.
 HTD with steel reinforcement, no backlash when changing direction, repeatability ± 0,1 mm.

Forces and torques

Size	ELSZ 30		ELSZ 40		ELSZ 60		ELSZ 60 S		ELSZ 80		ELSZ 80 S		ELSZ 100		ELSZ 125	
	static	dynam.	static	dynam.	static	dynam.	static	dynam.	static	dynam.	static	dynam.	static	dynam.	static	dynam.
Forces/Torques																
F_x (N)	390	350	894	800	1900	1800	1900	1800	4000	3800	4000	3800	5900	5750	7900	7500
F_y (N)	90	60	1200	700	3000	2000	4100	3100	3000	2000	4600	3600	8000	6500	12000	9000
F_z (N)	90	60	900	650	1700	1100	2160	1600	1700	1100	3000	1800	3600	2200	6000	4500
M_x (Nm)	10	5	25	20	67	43	88	65	90	55	170	140	300	230	600	450
M_y (Nm)	13	6	32	18	90	70	190	140	110	80	270	230	400	270	750	600
M_z (Nm)	14	7	35	25	120	100	230	170	150	120	300	220	750	500	1350	1150
All forces and torques relate to the following:																
existing values $\frac{F_y}{F_{y_{dyn}}} + \frac{F_z}{F_{z_{dyn}}} + \frac{M_x}{M_{x_{dyn}}} + \frac{M_y}{M_{y_{dyn}}} + \frac{M_z}{M_{z_{dyn}}} \leq 1$																
No-load torque																
Nm	0,5		0,7		0,9		0,9		1,2		1,2		1,5		1,8	
Speed																
(m/s) max	2		4		5		7		8		8		8		8	
Tensile force																
permanent (N)	390		894		1 900		1900		4000		4000		5900		7900	
0,2 s (N)	480		480		2090		2090		4300		4300		6350		8500	
Geometrical moments of inertia of aluminium profile																
I_x mm ⁴	4,09x10 ⁴		1,32x10 ⁵		6,79x10 ⁵		6,79x10 ⁵		18,99x10 ⁵		18,99x10 ⁵		44,4x10 ⁵		101,5x10 ⁵	
I_y mm ⁴	4,00x10 ⁴		1,34x10 ⁵		6,97x10 ⁵		6,97x10 ⁵		18,97x10 ⁵		18,97x10 ⁵		44,8x10 ⁵		101,5x10 ⁵	
E-Modulus N/mm ²	70000		70000		70000		70000		70000		70000		70000		70000	

For life-time calculation of rollers use our homepage.

Driving torque:

$$M_o = \frac{F \cdot P \cdot S_i}{2000 \cdot \pi} + M_n$$

$$P_o = \frac{M_o \cdot n}{9550}$$

- F = force (N)
- P = pulley action perimeter (mm)
- S_i = safety factor 1,2 ... 2
- M_n = no-load torque (Nm)
- n = rpm pulley (min⁻¹)
- M_o = driving torque (Nm)
- P_o = motor power (KW)

Deflection:

$$f = \frac{F \cdot L^3}{E \cdot I \cdot 192}$$

- f = deflection (mm)
- F = load (N)
- L = free length (mm)
- E = elastic modulus 70000 (N/mm²)
- I = second moment of area (mm⁴)

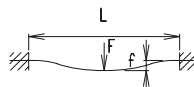

Positioning system ELSZ 30, 40, 60, 60S, 80, 80S, 100, 125

Dimensions (mm)

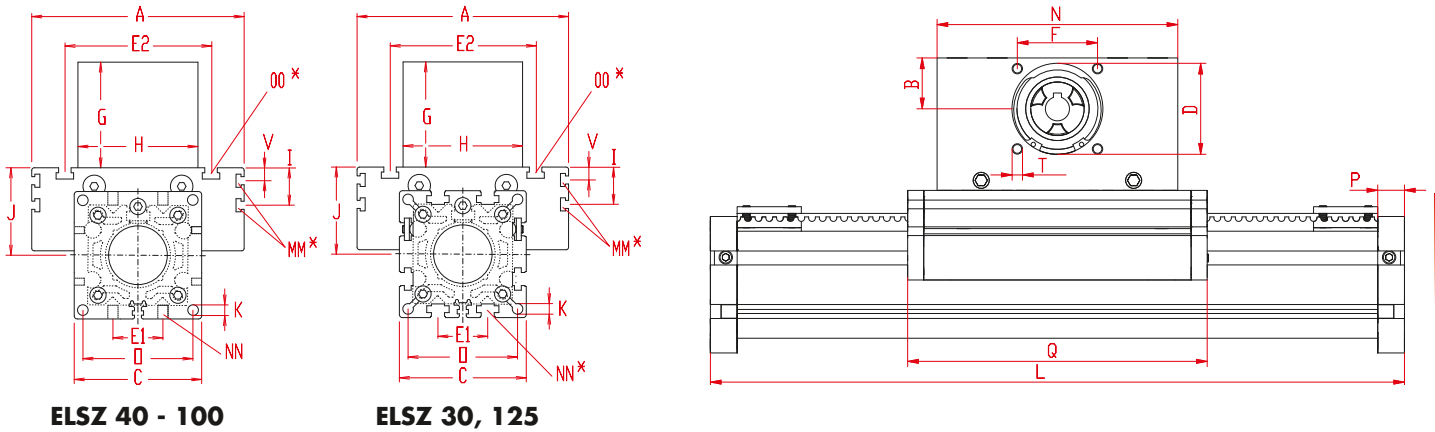

3.1

*For slide nuts refer to chapter 2.2 page 2

Increasing the carriage length will increase the basic length by the same amount.

Size	Basic length L	A	B	C	D _{-0,05}	E1	E2	F	G	H	I	J	K	MM for	N	NN for	O	OO for	P	Q	T	V	Basic weight	Weight per 100 mm
ELSZ 30	210	70	20	42	37	-	56	32	55	60	-	26	4,2	-	110	M 6	35	M 6	12	128	M 5	-	1,5 kg	0,16 kg
ELSZ 40	260	100	30	58	47	18	66	42	83	80	-	35	6,5	-	130	M 6	47	M 6	12	164	M 6	-	2,7 kg	0,24 kg
ELSZ 60	355	144	39	82	68	30	96	60	105	100	-	49	8,5	-	180	M 8	69	M 8	16	214	M 8	-	6,3 kg	0,62 kg
ELSZ 60S	355	170	39	82	68	30	108	60	105	100	-	53	8,5	-	180	M 8	69	M 8	16	214	M 8	-	7,3 kg	0,62 kg
ELSZ 80	460	170	60	102	90	40	117	80	140	130	30	70	8,5	M 6	270	M 10	88	M 10	20	304	M 10	10	14,0 kg	1,00 kg
ELSZ 80S	460	190	60	102	90	40	126	80	140	130	30	71	8,5	M 6	270	M 10	88	M 8	20	304	M 10	12,5	15,0 kg	1,00 kg
ELSZ 100	575	230	62	130	110	50	155	100	143	160	29	89	M 12	M 10	310	M 10	112	M 10	30	350	M 10	-	31,0 kg	1,60 kg
ELSZ 125	605	295	62	165	110	60	200	100	139	180	30	107,5	M 12	M 10	310	M 12	140	M 12	30	365	M 10	-	57,4 kg	1,96 kg

0 Choice of guide body profile:

- (0) Standard (2) corrosion-protected guide rods and screws
- (4) expanded corrosion-protected version (depending on the availability of components)

0 Choice of carriages:

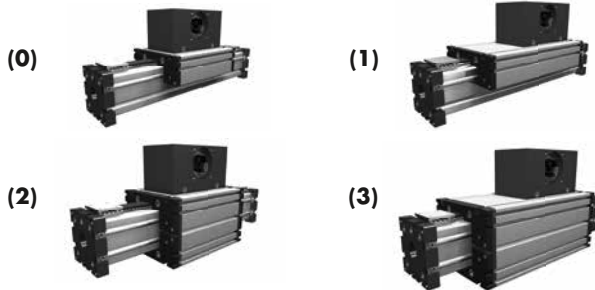

Size	Version 1		Version 2		Version 3	
	Q	L	Q	L	Q	L
30	195	279	140	222	207	291
40	257	355	180	276	273	371
60	353	494	230	371	369	510
60S	379	520	234	375	399	540
80	469	625	320	476	485	641
80S	489	645	324	480	509	665
100	575	800	366	591	591	816
125	640	870	389	619	664	894

0 Drive version:

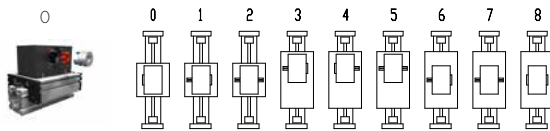

The standard version is supplied without shaft. A shaft can be retrofitted by inserting it into the pulley bore and securing it with 2 locking rings or tension sets (size 80 + 100).

Version 8 is the same as 0, but with double sided coupling claw.

Belt table

Code No.	Size	Belt	mm/rev.	Number of teeth
0 3	30	5M15	100	20
0 4	40	5M25	130	26
0 7	60 (S)	8M30	192	24
0 9	80 (S)	8M50	256	32
1 0	100	8M70	304	38
1 4	125	8M100	304	38

Shaft dimensions / Coupling claw

Size	Shaft ø h6 x length	Key	Coupling
30	10 x 27	3x3x25	9
40	14 x 35	5x5x28	14
60 (S)	18 x 45	6x6x40	19
80 (S)	22 x 45	6x6x40	24
100	30 x 55	8x7x50	28
125	40 x 55	12x8x50	—

Basic length + stroke = total length

ELSZ 60 0 0 0 0 0 7 1 01500

For combination kits and connecting elements refer to chapter 2.2

Pos. 1 2 3 4 5 6 7

Sample ordering code:

ELSZ 60 with standard body profile, standard carriage with widened belt and coupling claw on one side, 1170 mm stroke.

