

Positioning system ELZT 40, 60, 60S, 80, 80S, 100

Telescopic belt drive

Specifications

3.1

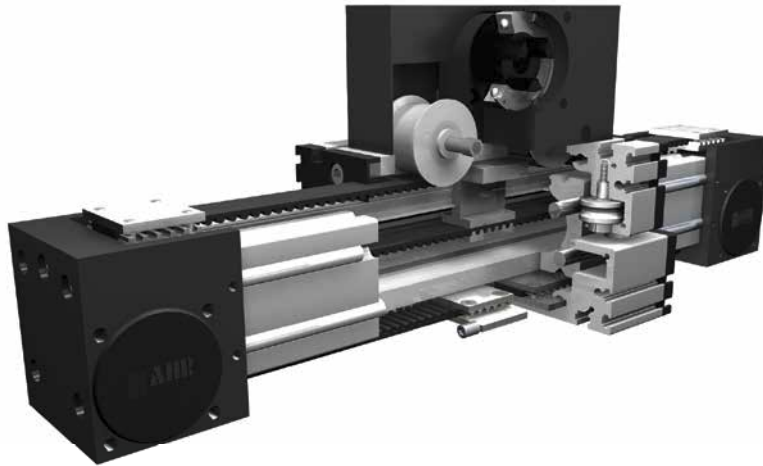

Function:

This unit consists of an aluminium square profile with integrated, hardened steel guide rods. Two carriages, which have internal linear ball bearings that can be adjusted free of play, are driven along the guide rods in opposite directions by 2 belts. The pulleys include maintenance-free ball bearings. One belt is tensioned by a tensioning device within the carriage. The other timing belt is tensioned by a tensioning device within the bearing block. The carriage with the drive block (with motor) is screwed to the crosshead. A T-slot profile is screwed to the carriage as an extension arm which can be adjusted to any length (see functional diagram on page 3/20).

Fitting position: As required. Max. length 3.000 mm.

Unit mounting: By T-slots in the carriage, extension arm

Belt type: HTD with steel reinforcement, no backlash when changing direction, repeatability ± 0,1 mm.

Forces and torques	Size	ELZT 40		ELZT 60		ELZT 60 S		ELZT 80		ELZT 80 S		ELZT 100	
	Forces/torques	static	dynamic	static	dynamic	static	dynamic	static	dynamic	static	dynamic	static	dynamic
	F _x (N)	360	300	580	470	580	470	1800	1570	1800	1570	4000	3500
	F _y (N)	1200	700	3000	2000	4100	3100	3000	2000	4600	3600	8000	6500
	F _z (N)	900	650	1700	1100	2160	1600	1700	1100	3000	1800	3600	2200
	M _x (Nm)	25	20	67	43	88	65	90	55	170	140	300	230
	M _y (Nm)	32	18	90	70	190	140	110	80	270	230	400	270
	M _z (Nm)	35	25	120	100	230	170	150	120	370	310	750	500
All forces and torques relate to the following: existing values $\frac{F_y}{F_{y_{dyn}}} + \frac{F_z}{F_{z_{dyn}}} + \frac{M_x}{M_{x_{dyn}}} + \frac{M_y}{M_{y_{dyn}}} + \frac{M_z}{M_{z_{dyn}}} \leq 1$ table values													
No-load torque													
	Nm	0,9		1,1		1,1		1,3		1,2		2,4	
Speed													
	(m/s) max	4		5		7		6		8		8	
Tensile force													
	permanent (N)	360		580		580		1800		1800		4000	
	0,2 s (N)	450		700		700		2200		2200		4300	
Geometrical moments of inertia of aluminium profile													
	I _x mm ⁴	1,32x10 ⁵		6,79x10 ⁵		6,79x10 ⁵		18,99x10 ⁵		18,99x10 ⁵		44,4x10 ⁵	
	I _y mm ⁴	1,34x10 ⁵		6,97x10 ⁵		6,97x10 ⁵		18,97x10 ⁵		18,97x10 ⁵		44,8x10 ⁵	
	E-Modulus N/mm ²	70000		70000		70000		70000		70000		70000	

For life-time calculation of rollers use our homepage.

Driving torque:

$$M_o = \frac{F \cdot P \cdot S_i}{2000 \cdot \pi} + M_n$$

$$P_o = \frac{M_o \cdot n}{9550}$$

- F = force (N)
- P = pulley action perimeter (mm)
- S_i = safety factor 1,2 ... 2
- M_n = no-load torque (Nm)
- n = rpm pulley (min⁻¹)
- M_o = driving torque (Nm)
- P_o = motor power (KW)

Deflection:

$$f = \frac{F \cdot L^3}{E \cdot I \cdot 192}$$

- f = deflection (mm)
- F = load (N)
- L = free length (mm)
- E = elastic modulus 70000 (N/mm²)
- I = second moment of area (mm⁴)

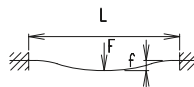

Positioning system ELZT 40, 60, 60S, 80, 80S, 100

Dimensions (mm)

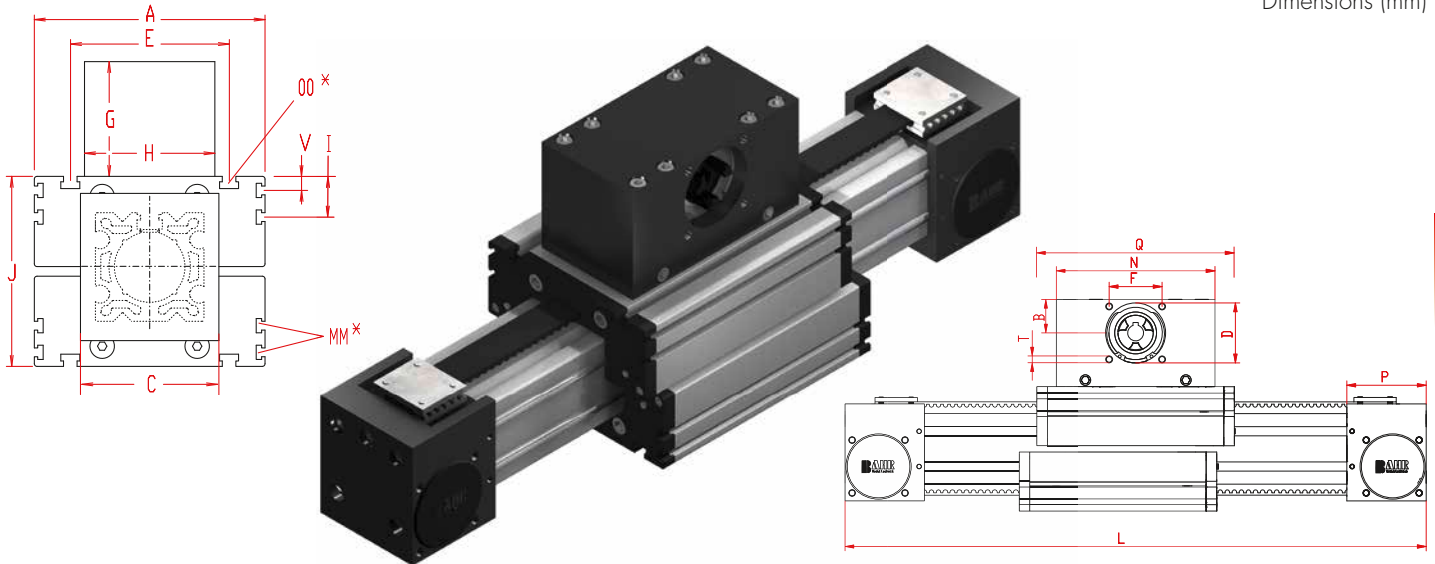

*For slide nuts refer to chapter 2.2 page 2

Increasing the carriage length will increase the basic length by the same amount.

Size	Basic length L	A	B	C	D -0,05	F	G	H	I	J	MM for	N	OO for	P	Q	T	V	Basic weight	Weight per 100 mm
ELZT 40	265	100	30	58	47	42	83	80	-	70	-	130	M 6	49	164	M 6	-	3,6 kg	0,31 kg
ELZT 60	345	144	39	80	68	60	105	100	-	98	-	180	M 8	59	218	M 8	-	9,1 kg	0,73 kg
ELZT 60S	370	170	39	80	68	60	105	100	-	106	-	180	M 8	59	220	M 8	-	10,1 kg	0,73 kg
ELZT 80	494	170	60	100	90	80	140	130	30	140	M 6	270	M 10	90	304	M 10	10	24,0 kg	1,14 kg
ELZT 80S	494	190	60	100	90	80	140	130	30	142	M 6	270	M 8	90	304	M 10	12,5	26,0 Kg	1,14 kg
ELZT 100	570	230	62	130	110	100	143	160	29	178	M 10	310	M 10	110	350	M 10	-	40,6 kg	1,95 kg

0 Choice of guide body profile:

- (0) Standard (2) corrosion-protected guide rods and screws
- (4) expanded corrosion-protected version (depending on the availability of components)

0 Choice of carriages:

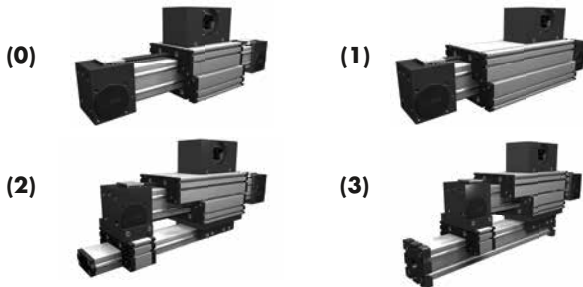

Size	Version 1		Version 2		Version 3	
	Q	L	Q	L	Q	L
40	257	360	257	360	257	360
60	353	480	353	480	353	480
60S	379	506	379	506	379	506
80	469	659	469	659	469	659
80S	489	679	489	679	489	679
100	575	795	575	795	575	795

0 Drive version:

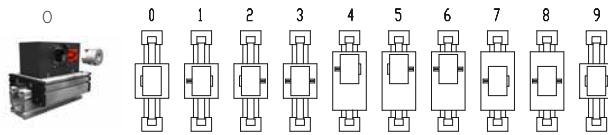

Version 9 is the same as 0, but with double sided coupling claw.

The standard version is supplied without shaft. A shaft can be retrofitted by inserting it into the pulley bore and securing it with 2 locking rings or tension sets (size 80 + 100).

Belt table

Code No.	Size	Belt	mm/rev.	Number of teeth
0 4	40	5M25	130	26
0 7	60 (S)	8M30	192	24
0 9	80 (S)	8M50	256	32
1 0	100	8M70	304	38

Shaft dimensions / Coupling Claw

Size	Shaft ø h6 x length	Key	Coupling
40	14 x 35	5x5x28	14
60 (S)	18 x 45	6x6x40	19
80 (S)	22 x 45	6x6x40	24
100	30 x 55	8x7x40	28

Basic length + 1/2stroke = total length

ELZT 60 6 0 0 0 0 4 1 01500

For combination kits and connecting elements refer to chapter 2.2

Pos. 1 2 3 4 5 6 7

Sample ordering code:

ELZT 60 with standard body profile, standard carriage and coupling claw on one side, 2310 mm stroke

