

# Positioning system ELZ 30, 40, 60, 60S, 80, 80S, 100, 125

Belt drive

Specifications



## Function:

This linear unit consists of an aluminium square profile with integrated, hardened steel guide rods. The carriage, which has internal linear ball bearings that can be adjusted free of play, is driven along the guide rods by a timing belt. The pulleys have maintenance-free ball bearings. Belt tension can be readjusted by a simple screw adjustment device in the carriage. This device can also be used for symmetrical adjustment of two or more linear units running parallel.

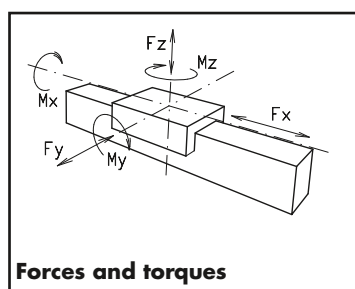

Forces and torques

## Fitting position:

As required. Max. length 6.000 mm without joints.

## Carriage mounting:

By T-slots.

## Unit mounting:

By T-slots or tapped holes in the bearing block, mounting sets.

## Belt type:

HTD with steel reinforcement, no backlash when changing direction, repeatability:  $\pm 0,1$  mm.

Size	ELZ 30		ELZ 40		ELZ 60		ELZ 60 S		ELZ 80		ELZ 80 S		ELZ 100		ELZ 125	
Forces/Torques	static	dynamic	static	dynamic	static	dynamic	static	dynamic	static	dynamic	static	dynamic	static	dynamic	static	dynamic
$F_x$ (N)	200	180	390	350	894	800	894	800	1900	1800	1900	1800	4000	3800	5900	5750
$F_y$ (N)	90	60	1200	700	3000	2000	4100	3100	3000	2000	4600	3600	8000	6500	12000	9000
$F_z$ (N)	90	60	900	650	1700	1100	2160	1600	1700	1100	3000	1800	3600	2200	6000	4500
$M_x$ (Nm)	10	5	25	20	67	43	88	65	90	55	170	140	300	230	600	450
$M_y$ (Nm)	13	6	32	18	90	70	190	140	110	80	270	230	400	270	750	600
$M_z$ (Nm)	14	7	35	25	120	100	230	170	150	120	300	220	750	500	1350	1150
<b>All forces and torques relate to the following:</b>																
existing values $\frac{F_y}{F_{y_{dyn}}} + \frac{F_z}{F_{z_{dyn}}} + \frac{M_x}{M_{x_{dyn}}} + \frac{M_y}{M_{y_{dyn}}} + \frac{M_z}{M_{z_{dyn}}} \leq 1$																
table values $\frac{F_y}{F_{y_{dyn}}} + \frac{F_z}{F_{z_{dyn}}} + \frac{M_x}{M_{x_{dyn}}} + \frac{M_y}{M_{y_{dyn}}} + \frac{M_z}{M_{z_{dyn}}} \leq 1$																
<b>No-load torque</b>																
Nm	0,2		0,3		0,6		0,7		0,9		1,2		1,4		1,8	
<b>Speed</b>																
(m/s) max	2		4		5		7		6		8		10		10	
<b>Tensile force</b>																
permanent (N)	200		390		900		900		1900		1900		4000		5900	
0,2 s (N)	280		480		1000		1000		2090		2090		4300		6350	
<b>Geometrical moments of inertia of aluminium profile</b>																
$I_x$ mm <sup>4</sup>	4,09x10 <sup>4</sup>		1,32x10 <sup>5</sup>		6,79x10 <sup>5</sup>		6,79x10 <sup>5</sup>		18,99x10 <sup>5</sup>		18,99x10 <sup>5</sup>		44,4x10 <sup>5</sup>		101,5x10 <sup>5</sup>	
$I_y$ mm <sup>4</sup>	4,00x10 <sup>4</sup>		1,34x10 <sup>5</sup>		6,97x10 <sup>5</sup>		6,97x10 <sup>5</sup>		18,97x10 <sup>5</sup>		18,97x10 <sup>5</sup>		44,8x10 <sup>5</sup>		101,5x10 <sup>5</sup>	
E-Modulus N/mm <sup>2</sup>	70000		70000		70000		70000		70000		70000		70000		70000	

For life-time calculation of rollers use our homepage.

Driving torque:

$$M_o = \frac{F \cdot P \cdot S_i}{2000 \cdot \pi} + M_n$$

$$P_o = \frac{M_o \cdot n}{9550}$$

$F$  = force (N)  
 $P$  = pulley action perimeter (mm)  
 $S_i$  = safety factor 1,2 ... 2  
 $M_n$  = no-load torque (Nm)  
 $n$  = rpm pulley (min<sup>-1</sup>)  
 $M_o$  = driving torque (Nm)  
 $P_o$  = motor power (KW)

Deflection:

$$f = \frac{F \cdot L^3}{E \cdot I \cdot 192}$$

$f$  = deflection (mm)  
 $F$  = load (N)  
 $L$  = free length (mm)  
 $E$  = elastic modulus 70000 (N/mm<sup>2</sup>)  
 $I$  = second moment of area (mm<sup>4</sup>)

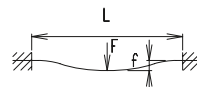

# Positioning system ELZ 30, 40, 60, 60S, 80, 80S, 100, 125

Dimensions (mm)

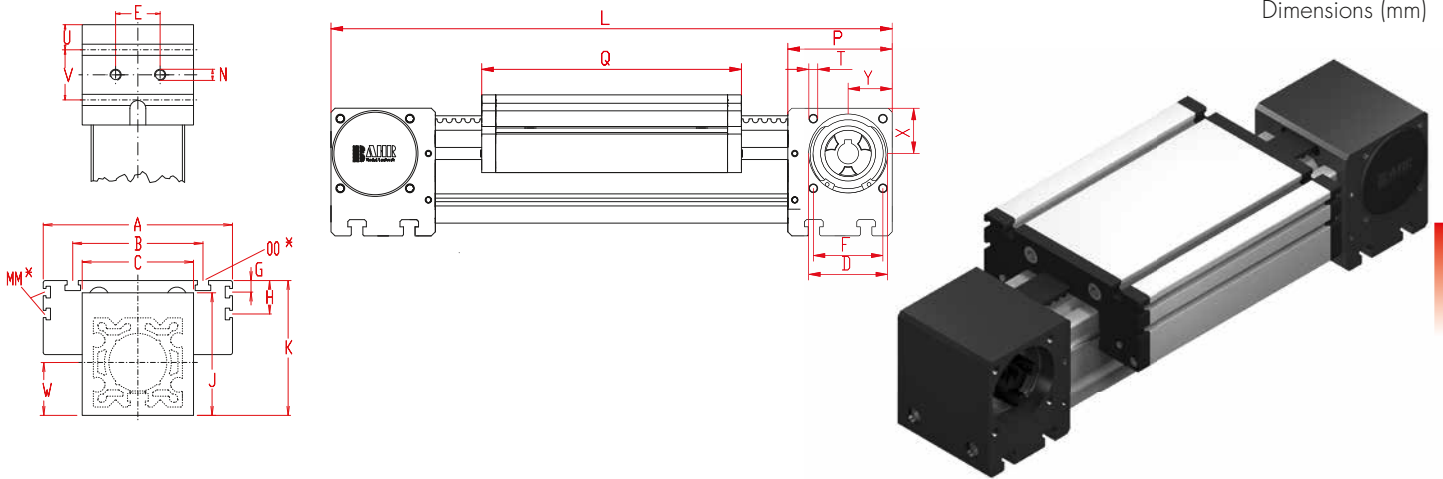

3.1

\*For slide nuts refer to chapter 2.2 page 2

Increasing the carriage length will increase the basic length by the same amount.

Size	Basic length L	A	B	C	D -0,05	E	F	G	H	J	K	MM for	N	OO for	P	Q	T	U	V	W	X	Y	Basic weight	Weight per 100 mm
ELZ 30	158	70	56	42	28	13	25	-	-	44	47	-	M 5	M 6	36	82	M 4	10	16	21	16	16	0,8 kg	0,13 kg
ELZ 40	225	100	66	58	37	18	32	-	-	58	64	-	M 6	M 6	49	122	M 5	12,5	24	29	20,5	20,5	1,9 kg	0,24 kg
ELZ 60	290	144	96	80	47	30	42	-	-	82	90	-	M 8	M 8	59	168	M 6	15	30	41	27	26	4,8 kg	0,62 kg
ELZ 60 S	315	170	108	80	47	30	42	-	-	82	94	-	M 8	M 8	59	194	M 6	15	30	41	27	26	5,8 kg	0,62 kg
ELZ 80	375	170	117	100	68	40	60	10	30	110	121	M 6	M 10	M 10	90	194	M 8	22,5	45	51	39	38	10,0 kg	1,00 kg
ELZ 80 S	395	190	126	100	68	40	60	12,5	30	110	122	M 6	M 10	M 8	90	214	M 8	22,5	45	51	39	38	11,0 kg	1,00 kg
ELZ 100	530	230	155	130	90	50	80	-	29	135	154	M 10	M 12	M 10	110	300	M 10	23	64	65	50	50	24,0 kg	1,60 kg
ELZ 125	625	295	200	160	110	60	100	-	30	167	191	M 10	M 12	M 12	130	365	M 10	38	50	82	60	60	37,0 kg	2,10 kg

**0 Choice of guide body profile:**

- (0) Standard
- (2) corrosion-protected guide rods and screws
- (4) expanded corrosion-protected version (depending on the availability of components)

**0 Choice of carriages:**



Size	Version 1	
	Q	L
30	94	170
40	138	241
60	184	306
60S	214	335
80	210	391
80S	234	415
100	316	546
125	389	649

**0 Drive version:**

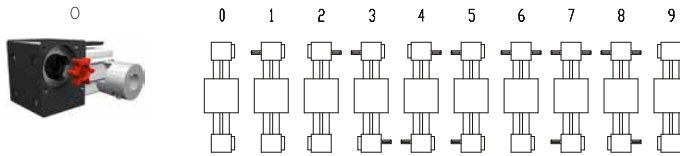

Version 9 is the same as 0, but with double sided coupling claw.

The standard version is supplied without shaft. A shaft can be retrofitted by inserting it into the pulley bore and securing it with 2 locking rings or tension sets (size 100 and 125).

**Belt table**

Code No.	Size	Belt	mm/rev.	Number of teeth
0 1	30	3M12	75	25
0 3	40	5M15	100	20
0 4	60 (S)	5M25	130	26
0 7	80 (S)	8M30	192	24
0 9	100	8M50	256	32
1 0	125	8M70	304	38

**Shaft dimensions / Coupling claw**

Size	Shaft ø h6 x length	Key	Coupling
30	6 x 15	2x2x12	7
40	10 x 27	3x3x25	9
60 (S)	14 x 35	5x5x28	14
80 (S)	18 x 45	6x6x40	19
100	22 x 45	6x6x40	24
125	30 x 55	8x7x50	28

Basic length + stroke = total length

ELZ 40 1 0 0 0 0 3 1 01500

For combination kits and connecting elements refer to chapter 2.2

Pos. 1 2 3 4 5 6 7

Sample ordering code:

ELZ 40 with standard body profile, standard carriage, coupling claw on one side, 1275 mm stroke.



# Positioning system ELZ 30, 40, 60, 60S, 80, 80S, 100, 125

Belt drive with two carriages moving in opposite directions

Dimensions (mm)

3.1

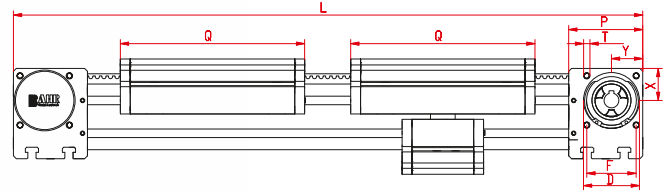
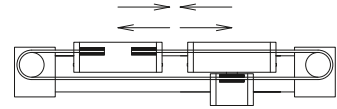
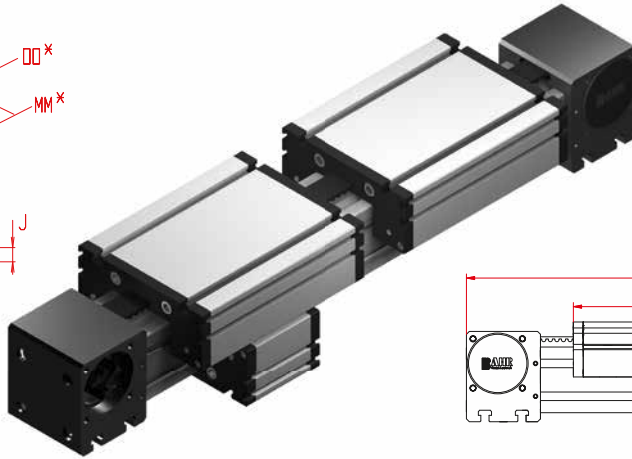
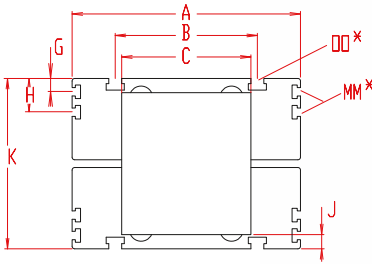

\*For slide nuts refer to chapter 2.2 page 2

Increasing the carriage length will increase the basic length by the same amount.

Size □	Basic length L	A	B	C	D -0,05	F	G	H	J	K	MM for	OO for	P	Q	T	X	Y	Basic weight	Weight per 100 mm
ELZ 30	250	70	56	42	28	25	-	-	5	52	-	M 6	36	82	M 4	16	16	1,2 kg	0,13 kg
ELZ 40	350	100	66	58	37	32	-	-	6	70	-	M 6	49	122	M 5	20,5	20,5	2,8 kg	0,24 kg
ELZ 60	460	144	96	80	47	42	-	-	8	98	-	M 8	59	168	M 6	27	26	7,4 kg	0,62 kg
ELZ 60S	510	170	108	80	47	42	-	-	12	106	-	M 8	59	194	M 6	27	26	7,4 kg	0,62 kg
ELZ 80	570	170	117	100	68	60	10	30	19	140	M 6	M10	90	194	M 8	39	39	15,0 kg	1,00 kg
ELZ 80S	610	190	126	100	68	60	12,5	30	21	142	M 6	M 8	90	214	M 8	39	39	17,0 kg	1,00 kg
ELZ 100	830	230	155	130	90	80	-	29	24	178	M10	M10	110	300	M10	50	50	34,0 kg	1,60 kg
ELZ 125	990	295	200	160	110	100	-	30	25,5	216	M10	M12	130	365	M10	60	60	53,5 kg	2,10 kg

**0 Choice of guide body profile:**

- (0) Standard (2) corrosion-protected guide rods and screws
- (4) expanded corrosion-protected version (depending on the availability of components)

Size	Version 1	
	Q	L
30	94	274
40	138	382
60	184	492
60S	214	554
80	210	602
80S	234	650
100	316	862
125	389	1038

**0 Choice of carriages:**



**0 Coupling - shaft mounting:**

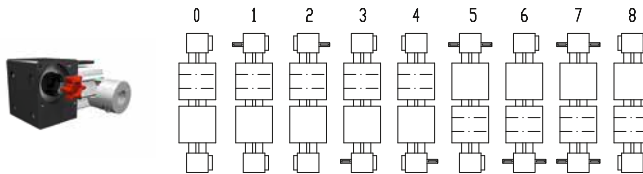

Version 8 is the same as 0, but with double sided coupling claw.

The standard version is supplied without shaft. A shaft can be retrofitted by inserting it into the pulley bore and securing it with 2 locking rings or tension sets (size 100 and 125).

**Belt table**

Code No.	Size	Belt	mm/rev.	Number of teeth
0 1	30	3M12	75	25
0 3	40	5M15	100	20
0 4	60 (S)	5M25	130	26
0 7	80 (S)	8M30	192	24
0 9	100	8M50	256	32
1 0	125	8M70	304	38

**Shaft dimensions / Coupling claw**

Size	Shaft ø h6 x length	Key	Coupling
30	6 x 15	2x2x12	7
40	10 x 27	3x3x25	9
60 (S)	14 x 35	5x5x28	14
80 (S)	18 x 45	6x6x40	19
100	22 x 45	6x6x40	24
125	30 x 55	8x7x50	28

Basic length + stroke = total length

ELZ 40 3 0 0 0 0 3 1 01500

Pos. 1 2 3 4 5 6 7

For combination kits and connecting elements refer to chapter 2.2

Sample ordering code:

ELZ 40, right/left hand with standard body profile, standard carriage, coupling claw on one side, 1150 mm stroke.

