

Belt drive

**Function:**

This unit consists of a square aluminium profile with an integrated roller guide. The carriage is driven by a timing belt. Each standard pulley includes one coupling claw on one side. Belt tension can be readjusted by a simple screw adjustment device in the carriage. This device can also be used for symmetrical adjustment of two or more linear units running parallel.

This linear unit is suitable for application in clean rooms of clean-room classification 1.000 (corresponding to US Fed. Standard 209 E).

Fitting position: As required. Max. length 6.000 mm without joints.

Carriage mounting: By T-slots.

Unit mounting: By T-slots and mounting sets. The linear axis can be combined with any T-slot profile.

Belt performance: HTD with steel reinforcement, no backlash when changing direction, repeatability $\pm 0,1$ mm.

Carriage support: In the standard version, the carriage runs on 4 rollers which can be adjusted and serviced at a central servicing position. For longer carriages the number of rollers can be increased.

Forces and torques	Size	60		80		100	
	Forces/Torques	static	dynamic	static	dynamic	static	dynamic
	F_x (N)	894	800	1900	1800	4000	3800
	F_y (N)	600	500	1600	1240	1900	1500
	F_z (N)	900	650	1500	1200	2100	1700
	M_x (Nm)	15	10	50	40	85	60
	M_y (Nm)	60	50	100	80	140	110
	M_z (Nm)	40	30	75	60	110	90
	All forces and torques related to the following:						
existing values	$\frac{F_y}{F_{y_{dyn}}} + \frac{F_z}{F_{z_{dyn}}} + \frac{M_x}{M_{x_{dyn}}} + \frac{M_y}{M_{y_{dyn}}} + \frac{M_z}{M_{z_{dyn}}} \leq 1$						
table values							
No-load torque							
Nm	0,6		0,8		1,2		
Speed							
(m/s) max	4		6		7		
Tensile force							
permanent (N)	900		1900		4000		
0,2 s (N)	1000		2090		4300		
Geometrical moments of inertia of aluminium profile							
I_x mm ⁴	4,3x10 ⁵		16,5x10 ⁵		43,0x10 ⁵		
I_y mm ⁴	4,8x10 ⁵		18,7x10 ⁵		48,8x10 ⁵		
Elastic modulus N/mm ²	70000		70000		70000		

For life-time calculation of rollers use our homepage.

Driving torque:

$$M_o = \frac{F \cdot P \cdot S_i}{2000 \cdot \pi} + M_n$$

$$P_o = \frac{M_o \cdot n}{9550}$$

F = force (N)
 P = pulley action perimeter (mm)
 Si = safety factor 1,2 ... 2
 Mn = no-load torque (Nm)
 n = rpm pulley (min⁻¹)
 Mo = driving torque (Nm)
 Po = motor power (KW)

Deflection:

$$f = \frac{F \cdot L^3}{E \cdot I \cdot 192}$$

f = deflection (mm)
 F = load (N)
 L = free length (mm)
 E = elastic modulus 70000 (N/mm²)
 I = second moment of area (mm⁴)

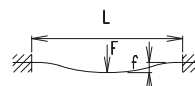

Positioning system QLZ 60, 80, 100

Dimensions (mm)

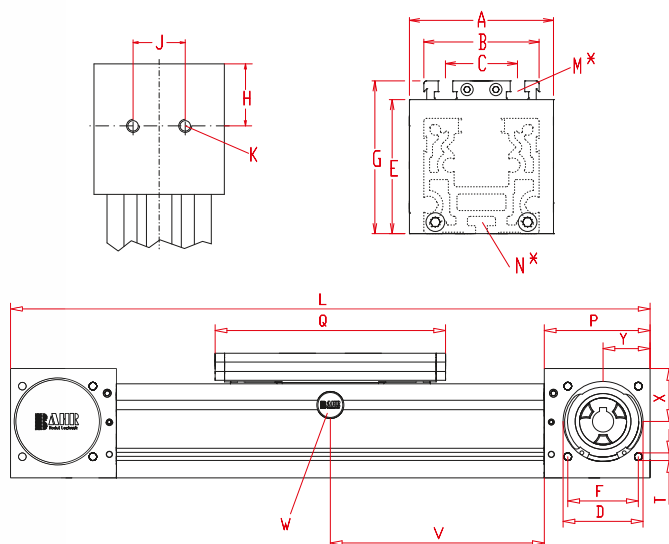

*For slide nuts refer to chapter 2.2 page 2
 $V = Q + 100 \text{ mm}$ $W =$ servicing position

Increasing the carriage length will increase the basic length by the same amount.

Size □	Basic length L	A	B	C	D -0,05	E	F	G	H	J	K	N for	M for	P	Q	T	X	Y	Basic weight	Weight per 100 mm
QLZ 60	280	80	60	36	47	63	42	79	29,5	30	M 8	M 5	M 6	59	152	M 6	27	26	3,2 Kg	0,39 kg
QLZ 80	390	100	80	50	68	93	60	106	47,5	40	M 10	M 6	M 8	90	196	M 8	45	40	9,6 Kg	0,86 Kg
QLZ 100	490	130	100	66	90	110	80	129	55	50	M 12	M 10	M 10	110	260	M 10	49	50	15,8 kg	1,23 Kg

5.1

0 Choice of guide body profile:

- (0) Standard
- (2) corrosion-protected guide rods and screws
- (4) expanded corrosion-protected version (depending on the availability of components)

0 Choice of carriages:

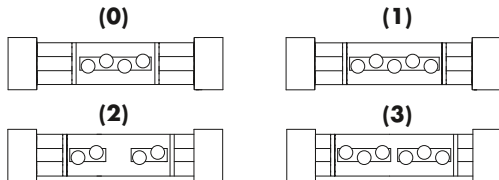

Size	Version 0		Version 1		Version 2		Version 3	
	Q	L	Q	L	Q	L	Q	L
60	152	280	192	320	>232	>360	>232	>360
80	196	390	246	440	>296	>490	>296	>490
100	260	490	320	550	>388	>610	>388	>610

0 Drive version:

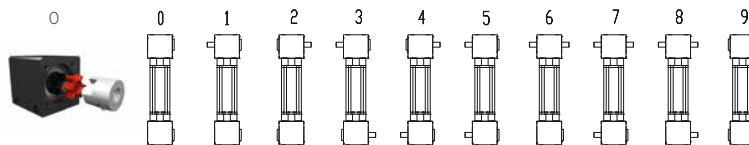

Size	Shaft ø h6 x length	Key
60	14 x 35	5x5x28
80	18 x 45	6x6x40
100	22 x 45	6x6x40

9 is as 0, but with coupling claws on both sides. The standard version is supplied without shaft. A shaft can be retrofitted by inserting it into the pulley bore and securing it with 2 locking rings or tension sets (size 100).

Belt table / Coupling claw

Code No.	Size	Belt	Pulley		Coupling
			mm/rev.	Number of teeth	
0 3	60	5M25	130	26	14
0 4	80	8M30	176	22	19
0 7	100	8M50	224	28	24

Basic length + stroke = total length

For additional accessories refer to chapter 2.2 – 3.2

QLZ 80 1 0 0 0 0 4 1 01500

Pos. 1 2 3 4 5 6 7

Sample ordering code:

QLZ80, standard body profile, standard carriage, coupling claw on one side, 1110 mm stroke

