

AKD[®]2G-Sxx with Functional Safety Option 2

SS1, STO, SBC, SBT - SIL3, FSoE

Installation Manual, English



Manual Edition: A, May 2021
 Safety Edition: S201, May 2021
 Valid for AKD[®]2G-S Hardware Revision A
 Part Number 907-200019-00

Original Document



For safe and proper use, follow these instructions. Keep for future use.



Record of Document Revisions

Edition	Remarks
...	Table with lifecycle information of this document (→ # 283)
A, 05/2021	First edition

Hardware Revision (HR)

AKD2G	Firmware	Workbench	KAS IDE	Remarks
A	from 02-00-00-000	from 2.00.0.0000	from 3.01	First revision

Trademarks

- AKD is a registered trademark of Kollmorgen Corporation.
- SafeMotion is a registered trademark of Kollmorgen Corporation.
- SMM is a registered trademark of Kollmorgen Corporation.
- EnDat is a registered trademark of Dr. Johannes Heidenhain GmbH.
- EtherCAT® and Safety over EtherCAT® are registered trademarks and patented technologies, licensed by Beckhoff Automation GmbH, Germany.
- EtherNet/IP is a registered trademark of ODVA, Inc.
- MODBUS is a registered trademark of SCHNEIDER ELECTRIC USA, INC..
- HIPERFACE is a registered trademark of Max Stegmann GmbH.
- PROFINET is a registered trademark of PROFIBUS and PROFINET International (PI).
- Windows is a registered trademark of Microsoft Corporation.

Current patents

- US Patent 2017/0211640 (method and apparatus for power saving, fail-safe control of an electromechanical brake), patent pending
- US Patent 16,247,478 (method and apparatus for limiting the output voltages of switching mode power supplies), patent pending
- US Patent 8,154,228 (Dynamic Braking For Electric Motors)
- US Patent 8,214,063 (Auto-tune of a Control System Based on Frequency Response)
- US Patent 10.374.468 (System and method for improved DC power line communication)

Patents referring to fieldbus functions are listed in the matching fieldbus manual.

Technical changes which improve the performance of the device may be made without prior notice!

This document is the intellectual property of Kollmorgen. All rights reserved. No part of this work may be reproduced in any form (by photocopying, microfilm or any other method) or stored, processed, copied or distributed by electronic means without the written permission of Kollmorgen.

1 Table of Contents

1	Table of Contents	3
2	General	11
2.1	About this Installation Manual	12
2.2	Using the PDF Format	12
2.3	Symbols Used	13
2.4	Abbreviations Used	14
3	Product Safety	15
3.1	You should pay attention to this	16
3.2	Use as Directed	18
3.3	Prohibited Use	19
3.4	Warning note labels	19
3.4.1	Notes placed on the product	19
3.4.2	Adhesive label in the package	19
3.5	Shock-hazard Protection	20
3.5.1	Leakage current	20
3.5.2	Residual current protective device (RCD)	20
3.5.3	Isolating transformers	20
3.6	Stop / Emergency Stop / Emergency Off	21
3.6.1	Stop	21
3.6.2	Emergency Stop	22
3.6.3	Emergency Off	22
4	Product life cycle handling	23
4.1	Transport	24
4.2	Packaging	24
4.3	Storage	24
4.4	Installation, setup and normal operation	25
4.5	Decommissioning	25
4.6	Maintenance and cleaning	25
4.7	Disassembly	25
4.8	System Repair	26
4.9	Disposal	26
5	Package	27
5.1	Package Supplied	28
5.2	Nameplate	28
5.3	Part Number Scheme	29
6	Technical description and data	30
6.1	The AKD2G Family of Digital Drives	31
6.2	Ambient Conditions, Ventilation and Mounting Position	33
6.3	Mechanical Data	33
6.4	Performance Data	34
6.5	Electrical data	35
6.5.1	Single axis variants (S)	35
6.5.1.1	Mains supply data, 1 phase AC, type AKD2G-Sxx- (S)	35
6.5.1.2	Mains supply data, 3 phase AC, type AKD2G-Sxx- (S)	35
6.5.1.3	Mains supply data, DC, type AKD2G-Sxx- (S)	35
6.5.1.4	Auxiliary voltage input data, 24VDC, type AKD2G-Sxx- (S)	35
6.5.1.5	Output data, type AKD2G-Sxx- (S)	36
6.5.2	Dual axis variants (D: I1=I2)	37
6.5.2.1	Mains supply data, 1 phase AC, type AKD2G-Sxx- (D)	37
6.5.2.2	Mains supply data, 3 phase AC, type AKD2G-Sxx- (D)	37

6.5.2.3	Mains supply data, DC, type AKD2G-Sxx- (D)	37
6.5.2.4	Auxiliary voltage input data, 24VDC, type AKD2G-Sxx- (D)	37
6.5.2.5	Output data, type AKD2G-Sxx- (D)	38
6.6	Electrical Motor Braking	39
6.6.1	Drive Dynamic Braking	39
6.6.2	Regeneration braking	39
6.6.2.1	Functional description	39
6.6.2.2	Technical data for AKD2G-Sxx-6V	40
6.6.2.3	Technical data for AKD2G-Sxx-7V	40
6.7	LCD Display and Push-buttons (B1, B2)	41
6.8	Rotary Switches (S1, S2)	43
6.9	SD Card Slot	44
7	Mechanical Installation	45
7.1	Important Notes	46
7.2	Guide to Mechanical Installation	46
7.3	Dimensions	47
8	Electrical Installation	48
8.1	Important Notes	49
8.2	Guide to electrical installation	50
8.3	Wiring	51
8.3.1	General	51
8.3.2	Mating connectors	51
8.3.3	Cable and Wire Requirements	52
8.3.3.1	Cable material	52
8.3.3.2	Cable Length	52
8.3.3.3	T-Connector wiring	52
8.3.3.4	Cable cross sections and requirements	53
8.3.4	Protective Earth connection	54
8.4	EMI Noise Reduction	55
8.4.1	Recommendations for EMI noise reduction	55
8.4.2	Shielding with external shielding busbar	56
8.4.2.1	Shielding Concept	56
8.4.2.2	Shielding Busbar	57
8.4.3	Shielding connection to the drive	58
8.4.3.1	Shielding Concept	58
8.4.3.2	Grounding plates and shield connection clamps	59
8.4.3.3	Motor connector X1/X2 with shielding connection	59
8.5	Connection Overview	60
8.5.1	Connector Position AKD2G-Sxx-6VxxS	60
8.5.2	Connector Position AKD2G-Sxx-7VxxS	61
8.5.3	Connector Position AKD2G-Sxx-6VxxD	62
8.5.4	Connector Position AKD2G-Sxx-7VxxD	63
8.5.5	Wiring overview, single axis drive	64
8.5.6	Wiring overview, dual axis drive	65
8.5.7	Connector pinout	66
8.5.7.1	X1 and X2: Motor, Brake, Feedback 1	66
8.5.7.2	X3: Mains, regen resistor, DC-Bus	66
8.5.7.3	X4: Second Brake	67
8.5.7.4	X5: Feedback 2	67
8.5.7.5	X10: 24 VDC	67
8.5.7.6	X11, X12: EtherNet Fieldbus	68
8.5.7.7	X13, X14: CAN bus (optional)	68
8.5.7.8	X20: Service	68
8.5.7.9	X21: I/O, Feedback 4	69

8.5.7.10	X22: I/O, EEO2, Feedback 5	70
8.5.7.11	X23: I/O, EEO1, Feedback 3	71
8.5.7.12	X41: SFA Feedback converter, EEO3/EEO4 (accessory)	72
8.6	Power and Logic Voltage Supply (X3/X10)	73
8.6.1	Mains power supply connector X3	73
8.6.1.1	Wiring examples mains power supply	74
8.6.1.2	Fusing	77
8.6.2	Auxiliary voltage power supply connector X10	81
8.6.2.1	Fusing	81
8.6.2.2	Wiring example 24 VDC supply	81
8.7	DC Bus link connector X3	82
8.7.1	Fusing	82
8.7.2	Wiring example with T connectors	83
8.7.3	Wiring example with busbar	83
8.8	Regen resistor connector X3	84
8.8.1	Fusing and Wiring	84
8.9	Motor Power, Brake and Feedback connection	84
8.9.1	Motor connectivity, some examples	85
8.9.2	Motor single cable connection	85
8.9.2.1	Motor Power, Brake and Feedback connectors X1, X2	86
8.9.2.2	Feedback connectors X5, X41, X21, X22, X23	87
8.9.2.3	Secondary Brake connector X4	87
8.9.3	Motor dual cable connection	88
8.9.3.1	Motor power and motor brake connectors X1, X2	89
8.9.3.2	Feedback connectors X1, X2, X5, X41, X21, X22, X23	89
8.9.3.3	Secondary Brake connector X4	90
8.9.4	Motor Holding Brake Connection	91
8.9.4.1	Secondary Brake connector X4	93
8.9.5	Feedback Connection	94
8.9.5.1	Feedback Connectors X1, X2	95
8.9.5.2	Feedback Connector X5	96
8.9.5.3	Feedback Connector X21	97
8.9.5.4	Feedback Connector X22	98
8.9.5.5	Feedback Connector X23	99
8.9.5.6	Feedback Connector X41 (SFA, accessory)	100
8.10	EEO, Electronic Gearing, Master-Slave	101
8.10.1	Emulated Encoder Output (EEO)	101
8.10.2	Electronic Gearing	103
8.10.3	Master-Slave control	103
8.10.3.1	Master-Slave using connector X22	103
8.10.3.2	Master-Slave using optional connector X23 or X41	103
8.11	EtherNet Fieldbus Interface connector X11/X12	104
8.11.1	EtherCAT® and Safety over EtherCAT®	104
8.11.2	PROFINET (available 2021)	105
8.11.3	EtherNet/IP (available 2021)	106
8.12	CAN-Bus Interface connector X13/X14	107
8.12.1	CAN-Bus Topology	107
8.12.2	CAN-Bus Wiring	108
8.12.3	Baud rate for CAN-Bus	109
8.12.4	Node Address for CAN-Bus	109
8.12.5	CAN-Bus Termination	109
8.13	Service Interface connector X20	110
8.13.1	Possible Network Configurations	110
8.14	Modbus TCP connector X20	111

8.15 I/O Connectors X21/X22/X23	112
8.15.1 Technical data	113
8.15.2 Analog Input	114
8.15.3 Analog Output	115
8.15.4 Digital Inputs	116
8.15.4.1 Digital-In 1 and 2	116
8.15.4.2 Digital-In 3 to 12	117
8.15.4.3 Digital-In/Out 1 and 2	118
8.15.4.4 Digital-In/Out 3 to 6	119
8.15.5 Digital Outputs	120
8.15.5.1 Digital-Out 5 to 6	120
8.15.5.2 Digital-Out 7 and 8	121
8.15.5.3 Digital-In/Out 1 and 2	122
8.15.5.4 Digital-In/Out 3 to 6	122
8.15.5.5 Digital-Out 9, Relay contacts	123
9 Setup	124
9.1 Important Notes	125
9.2 Guide to drive setup	126
9.2.1 Initial Drive Test Procedure	126
9.2.1.1 Unpacking, mounting, and wiring the AKD2G	126
9.2.1.2 Minimum wiring for drive test without load, example	126
9.2.1.3 Confirm connections (example: directly to PC)	127
9.2.1.4 System integration	127
9.2.1.5 Install and start WorkBench	129
9.2.1.6 Setup the axis in WorkBench	129
9.2.1.7 Enable the axis (Hardware)	129
9.2.1.8 Move the motor axis	129
9.2.1.9 Tune the axis	129
9.2.2 WorkBench Installation	130
9.2.2.1 Use as directed	130
9.2.2.2 Software description	131
9.2.2.3 Hardware requirements	131
9.2.2.4 Operating systems	131
9.2.2.5 Installation under Windows 7/8/10	132
9.3 Switch-On and Switch-Off Behavior	133
9.3.1 Switch-on behavior in standard operation	134
9.3.2 Switch-off behavior	135
9.3.2.1 Switch-off behavior using the AXIS#.DIS command	135
9.3.2.2 Switch-off behavior using a digital input (controlled stop)	136
9.3.2.3 Switch-off behavior using STO input (uncontrolled stop)	136
9.3.2.4 Switch-off behavior in the event of a fault	137
9.4 Fault and Warning Messages	140
9.4.1 Fault and warning messages AKD2G	140
9.5 Troubleshooting	141
10 Safety Manual for FS2	142
10.1 General notes	143
10.1.1 Use as directed	144
10.1.2 Prohibited use	144
10.1.3 Abbreviations used for functional safety	145
10.1.4 Enclosure, wiring	146
10.2 Commissioning	147
10.2.1 First time commissioning	147
10.2.2 Recommissioning	148
10.2.3 Diagnostic Testing of safe inputs, safe outputs and STO	148

10.2.4 Diagnostic Testing of safe brake control	148
10.3 Safety Functions Option 2 (I/O, FSoE, SIL3 PLe)	149
10.3.1 Safety properties overview	150
10.3.1.1 Activation by FSoE	150
10.3.1.2 Activation by Safety Functions	150
10.3.1.3 Activation by safe digital inputs	151
10.3.1.4 Safety function response time calculation	155
10.3.2 Technical Data	156
10.3.2.1 Safe digital inputs	156
10.3.2.2 Safe digital outputs	157
10.3.2.3 Factory Default Settings	157
10.3.2.4 OSSD	158
10.3.2.5 FSoE	159
10.3.2.6 Motor brake requirements	161
10.3.3 STO (Safe Torque Off)	162
10.3.3.1 Description	162
10.3.3.2 Activation	163
10.3.3.3 Restart	163
10.3.3.4 Timing	164
10.3.3.5 Related Parameters	164
10.3.3.6 Setup in Workbench	165
10.3.3.7 Fault Reaction/ Failure Messages	165
10.3.3.8 Safety Diagnostic for safe I/Os view in WorkBench	165
10.3.3.9 Safety Properties	165
10.3.4 SS1-t (Safe Stop 1)	166
10.3.4.1 Description	166
10.3.4.2 Activation	166
10.3.4.3 Safety Properties	166
10.3.4.4 Restart	167
10.3.4.5 Timing	167
10.3.4.6 Related Parameters	168
10.3.4.7 Setup in Workbench	169
10.3.4.8 Fault Reaction/ Failure Messages	170
10.3.4.9 Safety State/ Status signals	170
10.3.5 SBC (Safe Brake Control)	171
10.3.5.1 Description	171
10.3.5.2 Test pulses	172
10.3.5.3 Activation	173
10.3.5.4 Restart	173
10.3.5.5 SBC Muting function	174
10.3.5.6 Related Parameters	174
10.3.5.7 Timing, SS1 followed by SBC without SDB	175
10.3.5.8 Timing, SS1 followed by SBC with SDB	176
10.3.5.9 Setup in Workbench	177
10.3.5.10 Fault Reaction/ Failure Messages	178
10.3.5.11 Safety State/ Status signals	178
10.3.5.12 Safety Properties	178
10.3.6 SBT (Safe Brake Test)	179
10.3.6.1 Description	179
10.3.6.2 Activation	181
10.3.6.3 Related Parameters	181
10.3.6.4 Timing	182
10.3.6.5 Setup in Workbench	183

10.3.6.6	Fault Reaction/ Failure Messages	183
10.3.6.7	Safety State/ Status signals	184
10.3.7	SDB (Safe Dynamic Brake)	185
10.3.7.1	Description	185
10.3.7.2	Activation	186
10.3.7.3	Restart	187
10.3.7.4	Timing	187
10.3.7.5	Related Parameters	188
10.3.7.6	Setup in Workbench	188
10.3.7.7	Fault Reaction/ Failure Messages	188
10.3.7.8	Safety State/ Status signals	189
10.3.7.9	Safety Properties	189
10.4	Settings	190
10.4.1	Display, Push-Buttons and Rotary Switches	190
10.4.2	Default safety parameters	191
10.4.3	SafeID	191
10.4.4	FSoE Node Address	192
10.4.5	Instances	192
10.4.6	Workbench Safety Function Setup	193
10.4.6.1	Project building (online)	194
10.4.6.2	Parameters Editor	197
10.4.6.3	Safety Parameter Download	200
10.4.6.4	Safety configuration diagram	203
10.4.6.5	Parameters Viewer	204
10.4.6.6	Diagnostics	204
10.4.6.7	SMM Settings	204
10.5	Validation	205
10.5.1	User log-in	205
10.5.2	Validation of SafeID	205
10.5.3	Validation of safety parameters	205
10.5.4	Validation of safe I/O installation	205
10.5.5	Validation Report	206
10.6	Operation	207
10.6.1	Operation States	208
10.6.2	Field replacement	208
10.7	Safety Faults, Safety Warnings	209
10.7.1	Drive LCD Display	209
10.7.2	Failure categories	210
10.7.3	SMM failure classification and behavior	210
10.7.4	Drive Safety Faults	211
10.7.5	Drive Safety Warnings	212
10.7.6	Troubleshooting safety functionality	213
10.8	Functional Safety Parameter Reference	214
10.8.1	Safety Parameters, sorted alphanumeric	217
10.8.1.1	AXIS#.SAFE.ACTIVE	217
10.8.1.2	AXIS#.SAFE.BRAKE#.STATE	217
10.8.1.3	AXIS#.SAFE.ERROR.ACTIVE	218
10.8.1.4	AXIS#.SAFE.FSOE.APPLPARAMLENGTH	219
10.8.1.5	AXIS#.SAFE.FSOE.COMMPARAMLENGTH	219
10.8.1.6	AXIS#.SAFE.FSOE.CONNECTIONID	220
10.8.1.7	AXIS#.SAFE.FSOE.CONNECTIONTYPE	220
10.8.1.8	AXIS#.SAFE.FSOE.LASTERROR	221

10.8.1.9	AXIS#.SAFE.FSOE.PROTOCOLVERSION	221
10.8.1.10	AXIS#.SAFE.FSOE.SAFETYADDR	222
10.8.1.11	AXIS#.SAFE.FSOE.SRACRC	222
10.8.1.12	AXIS#.SAFE.FSOE.STATE	223
10.8.1.13	AXIS#.SAFE.FSOE.WATCHDOGTIME	223
10.8.1.14	AXIS#.SAFE.FUNCTIONGRAPH	224
10.8.1.15	AXIS#.SAFE.FUNCTIONSTATUS	225
10.8.1.16	AXIS#.SAFE.RESTARTACK.REQUESTED	226
10.8.1.17	AXIS#.SAFE.SBC.ACTIVE	227
10.8.1.18	AXIS#.SAFE.SBT.ERROR	228
10.8.1.19	AXIS#.SAFE.SBT.MOVE	229
10.8.1.20	AXIS#.SAFE.SBT.SBA.ACTIVE	229
10.8.1.21	AXIS#.SAFE.SBT.STATE	230
10.8.1.22	AXIS#.SAFE.SS1_#.ACTIVE	230
10.8.1.23	AXIS#.SAFE.SS1_#.DEC	231
10.8.1.24	AXIS#.SAFE.SS1_#.INTERNALSTATE	232
10.8.1.25	AXIS#.SAFE.SS1_#.MODE	233
10.8.1.26	AXIS#.SAFE.STO.ACTIVE	233
10.8.1.27	AXIS#.SAFE.STO.REPORTFAULT	234
10.8.1.28	AXIS#.SAFE.TEMPWARNING.ACTIVE	235
10.8.1.29	AXIS#.SAFEPARAM.AXISCFGEN	235
10.8.1.30	AXIS#.SAFEPARAM.SBC.BRAKETIMEDELAY	236
10.8.1.31	AXIS#.SAFEPARAM.SBC.BRAKE#ATTACHED	237
10.8.1.32	AXIS#.SAFEPARAM.SBC.MUTINGSOURCE	238
10.8.1.33	AXIS#.SAFEPARAM.SBT.FUNCTIONACTIVATION	239
10.8.1.34	AXIS#.SAFEPARAM.SBT.MAXAPPLLOAD	239
10.8.1.35	AXIS#.SAFEPARAM.SBT.MAXMOTIONBRAKE#	240
10.8.1.36	AXIS#.SAFEPARAM.SBT.MAXTIMEINTERVAL	241
10.8.1.37	AXIS#.SAFEPARAM.SBT.TORQUEDURATION	241
10.8.1.38	AXIS#.SAFEPARAM.SDB.DELAYBEFOREDIAGNOSE	242
10.8.1.39	AXIS#.SAFEPARAM.SDB.DELAYBEFORESWITCHING	242
10.8.1.40	AXIS#.SAFEPARAM.SDB.FUNCTIONACTIVATION	243
10.8.1.41	AXIS#.SAFEPARAM.SDB.READBACKSOURCE	243
10.8.1.42	AXIS#.SAFEPARAM.SS1_#.FSOE	244
10.8.1.43	AXIS#.SAFEPARAM.SS1_#.FUNCTIONACTIVATION	244
10.8.1.44	AXIS#.SAFEPARAM.SS1_#.SAFEINPUT	245
10.8.1.45	AXIS#.SAFEPARAM.SS1_#.TIMETOSTO	245
10.8.1.46	AXIS#.SAFEPARAM.STO.FSOE	246
10.8.1.47	AXIS#.SAFEPARAM.STO.FUNCTIONACTIVATION	246
10.8.1.48	AXIS#.SAFEPARAM.STO.RESTARTACKMODE	247
10.8.1.49	AXIS#.SAFEPARAM.STO.RESTARTACKSOURCE	248
10.8.1.50	AXIS#.SAFEPARAM.STO.SAFEINPUT	249
10.8.1.51	BRAKE#.SAFE.SBT.ELAPSED	250
10.8.1.52	BRAKE#.SAFE.SBT.STATE	251
10.8.1.53	SAFE.CFGERROR	252
10.8.1.54	SAFE.CHANGEPASSWORD	253
10.8.1.55	SAFE.CLEARSAFEID	254
10.8.1.56	SAFE.CRC	255

10.8.1.57	SAFE.DEVICECRC	255
10.8.1.58	SAFE.ERROR	256
10.8.1.59	SAFE.ERRORINSTANCE	257
10.8.1.60	SAFE.ID	258
10.8.1.61	SAFE.IDANDCRC	258
10.8.1.62	SAFE.INVALIDATEPARAMS	259
10.8.1.63	SAFE.MONITOR#.AXIS	260
10.8.1.64	SAFE.MONITOR#.DATA	260
10.8.1.65	SAFE.MONITOR#.INSTANCE	261
10.8.1.66	SAFE.MONITOR#.SOURCE	261
10.8.1.67	SAFE.STATE	262
10.8.1.68	SAFE.SWITCH	263
10.8.1.69	SAFE.VALIDATEPARAM	264
10.8.1.70	SAFE.VALIDATIONLOG	265
10.8.1.71	SAFE.VERIFYFW	266
10.8.1.72	SAFEPARAM.IOFAILUREACKSOURCE	266
10.8.1.73	SAFEPARAM.SAFEFIELDDBUS.ACTIVATION	267
10.8.1.74	SAFEPARAM.SIN.DISTINCTPULSE	268
10.8.1.75	SAFEPARAM.SINDUAL#.EN	269
10.8.1.76	SAFEPARAM.SOUTDUAL#.EN	269
10.8.1.77	SAFEPARAM.SOUTDUAL#.SOURCE	270
10.8.1.78	SAFEPARAM.SOUT#.SOURCE	272
10.8.1.79	SINDUAL#.STATE	274
10.8.1.80	SIN#.STATE	274
10.8.1.81	SOUTDUAL#.STATE	275
10.8.1.82	SOUT#.STATE	275
11	Approvals	276
11.1	Conformance with UL/cUL	277
11.2	Conformance with CE	278
11.2.1	Functional Safety approval	279
11.2.2	Conformance with RoHS	279
11.2.3	Conformance with REACH	279
11.3	Conformance with EAC	279
12	Index	281
13	Record of document revisions	283
13.1	Limitations	283

2 General

2.1 About this Installation Manual	12
2.2 Using the PDF Format	12
2.3 Symbols Used	13
2.4 Abbreviations Used	14

2.1 About this Installation Manual

This document, the *AKD[®]2G Installation Manual* ("Instructions Manual" according to EC Machinery Directive 2006/42/EU), describes the AKD[®]2G series of digital drives and includes information needed to safely install an AKD2G.

This document is valid for AKD2G single axis drive or dual axis drive with 110 V to 240 V or 240 V to 480 V mains voltage.

- Output stages: 3 A or 6 A or 12 A rated current
- Programmability options: Base drive or Position Indexer drive
- Connectivity options: analog, CANopen, EtherCAT, PROFINET, EtherNet/IP
- I/O options: Extended I/O (X22), Feedback&EEO (X23)
- Functional Safety Option: FS2 with STO, SS1-t, SBC, SBT, SDB; SIL3 PLc

A digital version of this manual (pdf format) is available on the DVD included with your drive.

AKD2G information for use consists of:

- *Safety Notes*: multi-language document with safety information, part of product delivery in Europe, printed on paper DIN A5.
- *Installation Manual*: This document, describes the AKD2G series of digital drives and includes information needed to safely install an AKD2G.
- *WorkBench Online Help*: describes how to use your drive in common applications. It also provides tips for maximizing your system performance with the AKD2G. The *Online Help* includes the *Parameter and Command Reference Guide* which provides information for the parameters and commands used to program the AKD2G.
- *CAN-BUS Communication*: describes how to use your drive in CANopen applications.
- *EtherCAT Communication*: describes how to use your drive in EtherCAT applications. FSoE specification.
- *PROFINET Communication*: describes how to use your drive in PROFINET applications (available 2021).
- *EtherNet/IP Communication*: describes how to use your drive in EtherNet/IP applications (available 2021).
- *Accessories Manual*: provides information for accessories like cables and regen resistors used with AKD2G. Regional variants of this manual exist.

All documents can be downloaded from the Kollmorgen website www.kollmorgen.com.











2.2 Using the PDF Format

This document includes several features for ease of navigation











Cross References	Table of contents and index include active cross references.
Table of contents and index	Lines are active cross references. Click on the line and the appropriate page is accessed.
Page/chapter numbers in the text	Page/chapter numbers with cross references are active links.

2.3 Symbols Used

Warning Symbols

Symbol	Indication
	Indicates a hazardous situation which, if not avoided, will result in death or serious injury.
	Indicates a hazardous situation which, if not avoided, could result in death or serious injury.
	Indicates a hazardous situation which, if not avoided, could result in minor or moderate injury.
	Indicates situations which, if not avoided, could result in property damage.
	This symbol indicates important notes.
	Warning of a danger (general). The type of danger is specified by the text next to the symbol.
	Warning of danger from electricity and its effects.
	Warning of danger from hot surface.
	Warning of danger from suspended loads.
	Warning of danger from automatic start.

Drawing symbols

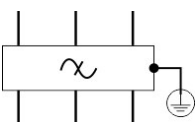
Symbol	Description	Symbol	Description
	Signal ground		Diode
	Chassis ground		Relay
	Protective earth		Relay switch off delayed
	Resistor		Normally open contact
	Fuse		Normally closed contact
	State-of-the-art firewall		EMC filter

2.4 Abbreviations Used

Abbreviations related to functional safety (→ # 145).

Abbreviation	Meaning
(→ # 53)	"see page 53" in this document
→ xyz	"see chapter xyz" in this document
Ω	Ohms
A#, AXIS#	A# or AXIS# are placeholders for the axis number. Used with parameters or signal names
AGND	Analog ground
AquadB	In quadrature output, used for incremental encoder emulation
AMSL	Above mean sea level
Axis	Depends on context, either one AKD2G output stage or one load axis of the full motion system.
CAT	Category
CE	Communauté Européenne
COM	Serial interface for a personal computer
DGND	Digital ground
EEPROM	Electrically erasable programmable memory
EEO	Emulated Encoder Output
EMC	Electromagnetic compatibility
EMF	Electromagnetic force
FS1, FS2, FS3	Functional Safety Option 1, 2, 3
FSoE	Fail safe over EtherCAT
KAS	Kollmorgen Automation Suite
KAS IDE	Setup software (Kollmorgen Automation Suite Integrated Development Environment)
KDN	Kollmorgen Developer Network
LED	Light-emitting diode
LSB	Low significant byte (or bit)
MSB	Most significant byte (or bit)
NI	Zero pulse
OSSD	Output Signal Switching Device
PE	Protective earth
PELV	Protective Extra Low Voltage
PLC	Programmable logic control
PWM	Pulse-width modulation
RAM	Random access memory (volatile memory)
RBrake/RB	Regen resistor (also called a brake resistor)
RBext	External regen resistor
RBint	Internal regen resistor
RCD	Residual current device
RES	Resolver
S1	Continuous operation
tbd	To be determined (in process)
VAC	Volts, alternating current
VDC	Volts, direct current

3 Product Safety

3.1 You should pay attention to this	16
3.2 Use as Directed	18
3.3 Prohibited Use	19
3.4 Warning note labels	19
3.5 Shock-hazard Protection	20
3.6 Stop / Emergency Stop / Emergency Off	21

3.1 You should pay attention to this

This section helps to recognize risks and avoid dangers to people and objects.

Specialist staff required!

The devices are intended for industrial applications. Machine builders must employ qualified personnel. Qualified personnel are people who have been trained to transport, install, commission and operate electrical drives.

- Transport, storage, unpacking: only by personnel with knowledge of handling electrostatically sensitive components.
- Mechanical installation: only by personnel with mechanical expertise.
- Electrical installation: only by personnel with expertise in electrical engineering.
- Basic tests / setup: only by personnel with expertise in electrical engineering and drive technology.

The qualified personnel must know and observe ISO 12100 / IEC 60364 / IEC 60664 and national accident prevention regulations.

Read the documentation!

Read the available documentation before installation and commissioning. Improper handling of the devices can cause harm to people or damage to property. The operator of systems using the drive system must ensure that all personnel who work with the drive read and understand the manual before using the drive.

Check Hardware Revision!

Check the Hardware Revision Number of the product (see product label). This number is the link between your product and the manual. The product Hardware Revision Number must match the Hardware Revision Number on the cover page of the manual.

Pay attention to the technical data!

Adhere to the technical data and the specifications on connection conditions. If permissible voltage values or current values are exceeded, the devices can be damaged. Unsuitable motor or wrong wiring will damage the system components. Check the combination of drive and motor. Compare the rated voltage and current of the units.

Perform a risk assessment!

The manufacturer of the machine must generate a risk assessment for the machine, and take appropriate measures to ensure that unforeseen movements cannot cause injury or damage to any person or property. Additional requirements on specialist staff may also result from the risk assessment.

Automatic restart

The drive might restart automatically after power on, voltage dip or interruption of the supply voltage, depending on the parameter setting. Risk of death or serious injury for humans working in the machine.

If the parameter `AXIS#.ENDEFAULT` is set to 1, then place a warning sign to the machine (Warning: Automatic Restart at Power On) and ensure, that power on is not possible, while humans are in a dangerous zone of the machine. In case of using an undervoltage protection device, you must observe EN 60204-1:2006 chapter 7.5 .

ATTENTION: The drive is ready to operate with pre-configured STO function.



Observe electrostatically sensitive components!

The devices contain electrostatically sensitive components which may be damaged by incorrect handling. Electrostatically discharge your body before touching the device. Avoid contact with highly insulating materials (artificial fabrics, plastic film etc.). Place the device on a conductive surface.

**Hot surface!**

Drives may have hot surfaces during operation. The housing can reach temperatures above 80°C. Risk of minor burns! Measure the temperature, and wait until the housing has cooled down below 40 °C before touching it.

**Earthing!**

It is vital that you ensure that the drive is safely earthed to the PE (protective earth) busbar in the switch cabinet. Risk of electric shock. Without low-resistance earthing no personal protection can be guaranteed.

Leakage Current!

Since the leakage current to PE is more than 3.5 mA, in compliance with IEC61800-5-1 the PE connection must either be doubled or a connecting cable with a cross-section >10 mm² must be used. Deviating measures according to regional standards might be possible.

**High voltages!**

The equipment produces high electric voltages up to 900 V. Lethal danger exists at live parts of the device. Do not open or touch the equipment during operation. Keep all covers and cabinet doors closed. Built-in protection measures such as insulation or shielding may not be removed. Work on the electrical installation may only be performed by trained and qualified personnel, in compliance with the regulations for safety at work, and only with switched off mains supply, and secured against restart.

Never undo any electrical connections to the drive while it is live. There is a danger of electrical arcing with damage to contacts and personal injury. Wait at least 5 minutes after disconnecting the drive from the main supply power before touching potentially live sections of the equipment (such as contacts) or removing any connections.

Always measure the voltage in the DC bus link and wait until the voltage is below 50 V before handling components.

Functional Safety!

The assessment of the safety functions according to EN13849 or EN 62061 must finally be done by the user.

Reinforced Insulation

Thermal sensors, motor holding brakes and feedback systems built into the connected motor must have reinforced insulation (according to IEC61800-5-1) against system components with power voltage, according to the required application test voltage. All Kollmorgen components meet these requirements.

Never modify the drive!

It is not allowed to modify the drive hardware without permission by the manufacturer. Opening the housing causes loss of warranty.

3.2 Use as Directed

The AKD2G drives are exclusively intended for driving suitable synchronous servomotors with closed-loop control of torque, speed, and/or position.

AKD2G are components that are built into electrical plants or machines and can only be operated as integral components of these plants or machines. The manufacturer of the machine used with a drive must generate a risk assessment for the machine. When the drives are built into machines or plant, the drive must not be used until it has been established that the machine or plant fulfills the requirements of the regional directives.

Cabinet and wiring

Drives must only be operated in a closed control cabinet suitable for the ambient conditions (→ # 33). Ventilation or cooling may be necessary to keep the temperature within the cabinet below 40 °C or 60 °C if using extended range operation with derating.

Use only copper conductors for wiring. The conductor cross-sections can be derived from the standard IEC 60204 (alternatively for AWG cross-sections: NEC Table 310-16, 75 °C column).

Power supply

The drives can be supplied by 1, 2 or 3 phase (TN-S or TT) or DC industrial supply networks.

Drives in the AKD2G series can be supplied as follows:

- AKD2G-Sxx-6Vxx:
1, 2 or 3 phase industrial supply networks (not more than 10 kA symmetrical rated current at 120 V and 240 V) or DC supply.
- AKD2G-Sxx-7Vxx:
3 phase industrial supply networks (not more than 10 kA symmetrical rated current at 240 V, 400 V and 480 V) or DC supply.

Connection to other voltage types of supply networks is possible with an additional isolating transformer.

Repeated overvoltages between phases (L1, L2, L3) and the housing of the drive must not exceed 1000 V peak. In accordance with IEC 61800, voltage spikes (< 50 µs) between phases must not exceed 1000 V. Voltage spikes (< 50 µs) between a phase and the housing must not exceed 2000 V.

Motor voltage rating

The rated voltage of the motors must be at least as high as the DC bus link voltage divided by $\sqrt{2}$ produced by the drive ($U_{nMotor} \geq U_{DC}/\sqrt{2}$).

Functional Safety

NOTICE

- The network, to which the drive is connected, must be secured according to state-of-the-art information technology security requirements.
- The user IT specialists shall analyze whether further security requirements are applicable to ensure functional safety.

Review the chapter "Use as Directed" in the Functional Safety section before using safety functionality.

3.3 Prohibited Use

Other use than that described in chapter “Use as directed” is not intended and can lead to personnel injuries and equipment damage. The drive may not be used with a machine that does not comply with appropriate national directives or standards. The use of the drive in the following environments is also prohibited:

- potentially explosive areas
- environments with corrosive and/or electrically conductive acids, alkaline solutions, oils, vapors, dusts
- ships or offshore applications

NOTICE

The drive must not be connected directly to the Internet. If the network, to which the drive is connected, is not secured according to state-of-the-art information technology, this could be a functional safety risk.

3.4 Warning note labels

3.4.1 Notes placed on the product



3.4.2 Adhesive label in the package

NOTICE

Follow the instructions given on the adhesive labels in the package. If a warning note label is damaged, it must be replaced immediately.

3.5 Shock-hazard Protection

3.5.1 Leakage current

Leakage current via the PE conductor results from the combination of equipment and cable leakage currents. The leakage current frequency pattern includes a number of frequencies, whereby the residual-current circuit breakers definitively evaluate the 50 Hz current. For this reason, the leakage current cannot be measured using a conventional multimeter. Contact our application department for help to calculate the leakage current in your application.

NOTE

Since the leakage current to PE is more than 3.5 mA, in compliance with IEC61800-5-1 the PE connection must either be doubled or a connecting cable with a cross-section >10 mm² must be used. Use the PE terminal and the PE connection screws in order to fulfill this requirement.

The following measures can be used to minimize leakage currents:

- Reduce the length of the engine cable.
- Use low capacitance motor cables (→ # 52).

3.5.2 Residual current protective device (RCD)

In conformity with IEC 60364-4-41 – Regulations for installation and IEC 60204 – Electrical equipment of machinery, residual current protective devices (RCDs) can be used provided the requisite regulations are complied with. The AKD2G is a 3-phase system with a B6 bridge. Therefore, RCDs which are sensitive to all currents must be used in order to detect any DC fault current.

Rated residual currents in the RCDs:

10 to 30 mA	Protection against "indirect contact" (personal fire protection) for stationary and mobile equipment, as well as for "direct contact".
50 to 300 mA	Protection against "indirect contact" (personal fire protection) for stationary equipment

NOTE

Recommendation: In order to protect against direct contact (with motor cables shorter than 5 m) Kollmorgen recommends that each drive be protected individually using a 30 mA RCD which is sensitive to all currents.

If you use a selective RCD, the more intelligent evaluation process will prevent spurious tripping of the RCD.

3.5.3 Isolating transformers

When protection against indirect contact is absolutely essential despite a higher leakage current, or when an alternative form of shock-hazard protection is sought, the AKD2G can also be operated by using an isolating transformer. A ground-leakage monitor can be used to monitor for short circuits.

NOTE

Keep the length of wiring between the transformer and the drive as short as possible.

3.6 Stop / Emergency Stop / Emergency Off

The control functions Stop, Emergency Stop and Emergency Off are defined by IEC 60204. Notes for functional safety aspects of these functions can be found in ISO 13849 and IEC 62061.

NOTE

The parameter `AXIS#.DISMODE` must be set to implement the different stop categories for software disabling. Consult the *WorkBench Online Help* for configuring the parameter.



WARNING Vertical load could fall!

Serious injury could result when the load is not properly blocked. The internal brake function does not ensure functional safety.

- Functional Safety can be ensured with configured SBC (→ # 171) only.
- For SIL 3 a second (external) motor brake for an axis is required. For single axis drives this brake can be connected to X4 (→ # 93). For dual axis drives the additional brake must be controlled from another source (e.g. from the other axis or externally from a safety controller). The brakes can be mapped to an axis with WorkBench.
- The Hardware Enable does not initiate a controlled stop but switches off the power stage immediately.
- Set parameter `AXIS#.MOTOR.BRAKEIMM` to 1 with vertical axes, to apply the brake immediately after faults or Hardware Disable.
- Risk assessment of the application determines the necessary measures.

3.6.1 Stop

The stop function shuts down the machine in normal operation. The stop function is defined by IEC 60204.

NOTE

The Stop Category must be determined by a risk evaluation of the machine.

Stop function must have priority over assigned start functions. The following stop categories are defined:

Stop Category 0

Shut-down by immediate switching-off the energy supply to the drive machinery (this is an uncontrolled shut-down).

For stop without using safety functions like STO, set `AXIS#.DISMODE` to 0.

The safety function STO stops the drive as required by Stop Category 0 (IEC 62061).

Stop Category 1

A controlled shut-down, whereby the energy supply to the drive machinery is maintained to perform the shut-down, and the energy supply is only interrupted when the shut-down has been completed.

For stop without using safety functions like SS1, set `AXIS#.DISMODE` to 2.

The safety function SS1 stops the drive as required by Stop Category 1 (IEC 62061).

Stop Category 2

A controlled shut-down, whereby the energy supply to the drive machinery is maintained. This category shall be realized with a safety function like SS2. Safety function SS2 stops the drive as required by Stop Category 2 (IEC 62061).

Stop Category 0 and Stop Category 1 stops must be operable independently of the operating mode, whereby a Category 0 stop must have priority.

If necessary, provision must be made for the connection of protective devices and lock-outs. If applicable, the stop function must signal its status to the control logic. A reset of the stop function must not create a hazardous situation.

3.6.2 Emergency Stop

The Emergency Stop function is used for the fastest possible shutdown of the machine in a dangerous situation. The Emergency Stop function is defined by IEC 60204. Principles of emergency stop devices and functional aspects are defined in ISO 13850.

The Emergency Stop function will be triggered by the manual actions of a single person. It must be fully functional and available at all times. The user must understand instantly how to operate this mechanism (without consulting references or instructions).

NOTE

The Stop Category for the Emergency Stop must be determined by a risk evaluation of the machine.

In addition to the requirements for stop, the Emergency Stop must fulfill the following requirements:

- Emergency Stop must have priority over all other functions and controls in all operating modes.
- The energy supply to any drive machinery that could cause dangerous situations must be switched off as fast as possible, without causing any further hazards (Stop Category 0) or must be controlled in such a way, that any movement that causes danger, is stopped as fast as possible (Stop Category 1).
- The reset must not initiate a restart.

3.6.3 Emergency Off

The Emergency Off function is used to switch-off the electrical power supply of the machine. This is done to prevent users from any risk from electrical energy (for example electrical impact). Functional aspects for Emergency Off are defined in IEC 60364-5-53.

The Emergency Off function will be triggered by the manual actions of a single person.

NOTE

The result of a risk evaluation of the machine determines the necessity for an Emergency Off function.

Emergency Off is done by switching off the supply energy by electro-mechanical switching devices. This results in a category 0 stop. If this stop category is not possible in the application, then the Emergency Off function must be replaced by other measures (for example by protection against direct touching).

4 Product life cycle handling

4.1 Transport	24
4.2 Packaging	24
4.3 Storage	24
4.4 Installation, setup and normal operation	25
4.5 Decommissioning	25
4.6 Maintenance and cleaning	25
4.7 Disassembly	25
4.8 System Repair	26
4.9 Disposal	26

4.1 Transport

Transport the AKD2G in accordance with IEC 61800-2 as follows:

- Transport only by qualified personnel in the manufacturer's original recyclable packaging.
- **NOTICE:** Avoid shocks while transporting.
- Vibration/Shock: AKD2G is tested for environmental class 2M1 of IEC 60721-3-2.
- Store at or below maximum stacking height 8 cartons (see "Storage" (→ # 24))
- Transport only within specified temperature ranges:
-25 to +70 °C, max. rate of change 20 K/hour, class 2K3.
- Transport only within specified humidity:
max. 95% relative humidity at +40°C, no condensation, class 2K3.

NOTICE

The drives contain electrostatically sensitive components that can be damaged by incorrect handling. Electrostatically discharge yourself before touching the drive. Avoid contact with highly insulating materials, such as artificial fabrics and plastic films. Place the drive on a conductive surface.

If the packaging is damaged, check the unit for visible damage. Inform the shipper and the manufacturer of any damage to the package or product.

4.2 Packaging

The AKD2G packaging consists of recyclable cardboard with inserts and a label on the outside of the box.

Model	Package (mm) HxWxL	Total Weight (kg)
AKD2G-Sxx-6V03 to 6V12	158 x 394 x 292	4.2
AKD2G-Sxx-7V03 to 7V12	158 x 394 x 292	4.3

NOTE

Mating connectors are **not** included in the package of a standard drive.

Mating connectors are included when the drive is ordered with accessories (append "-A" to the model number).

4.3 Storage

Store the AKD2G in accordance with IEC 61800-2 as follows:

- Store only in the manufacturer's original recyclable packaging.
- Store at or below maximum stacking height 8 cartons.
- Store only within specified temperature ranges: -25 to +55 °C, max.rate of change 20 K/hour, class 1K4.
- Storage only within specified humidity: 5 to 95% relative humidity, no condensation, class 1K3.
- Store in accordance with the following duration requirements:
 - Less than 1 year: without restriction.
 - More than 1 year: capacitors must be re-formed before setting up and operating the drive. Re-forming procedures are described in the KDN ([Forming](#)).

4.4 Installation, setup and normal operation

Installation and setup information are given in this manual:

- Mechanical installation (→ # 45)
- Electrical installation (→ # 48)
- Setup (→ # 124)

Normal operation tested for environmental class 3K3 according to IEC 61800-2 (→ # 33). The manufacturer of the machine defines the necessary end user expertise based on the risk assessment for the machine and describes the requirements for normal operation based on the application.

4.5 Decommissioning

NOTICE

Only professional staff who are qualified in electrical engineering are allowed to decommission parts of the system.

DANGER: Lethal Voltages!

There is a danger of serious personal injury or death by electrical shock or electrical arcing.

- Switch off the main switch of the switchgear cabinet.
- Secure the system against restarting.
- Block the main switch.
- Wait at least 5 minutes after disconnecting.

4.6 Maintenance and cleaning

The device does not require maintenance, it should be inspected once a year by professional staff.

NOTICE

Do not immerse or spray the device. Avoid that liquid enters the device. The inside of the unit can only be cleaned by the manufacturer. Opening the device voids the warranty.

To clean the device exterior:

1. Decommission the device (see chapter 4.5 "Decommissioning").
2. Casing: Clean with Isopropanol or similar cleaning solution.

Caution : Highly Flammable! Risk of injury by explosion and fire.

 - Observe the safety notes given on the cleaning liquid package.
 - Wait at least 30 minutes after cleaning before putting the device back into operation.
3. Protective grill on fan: Clean with a dry brush.

4.7 Disassembly

NOTICE

Only professional staff who are qualified in electrical engineering are allowed to disassemble parts of the system.

1. Decommission the device (see chapter 4.5 "Decommissioning").
2. Check temperature.

CAUTION: High Temperature! Risk of minor burns. During operation, the heat sink of the drive may reach temperatures above 80 °C (176 °F). Before touching the device, check the temperature and wait until it has cooled below 40 °C (104 °F).
3. Remove the connectors. Disconnect the potential earth connection last.
4. Demount: loosen the fastening screws. Remove the device.

4.8 System Repair

NOTICE

Only professional staff who are qualified in electrical engineering are allowed to exchange parts of the drive system.

CAUTION: Automatic Start! During replacement work a combination of hazards and multiple episodes may occur.

- Work on the electrical installation may only be performed by trained and qualified personnel, in compliance with the regulations for safety at work, and only with use of prescribed personal safety equipment.

Exchange of the device

Only the manufacturer can repair the device. Opening the device voids the warranty.

1. Decommission the device (see chapter 4.5 "Decommissioning").
2. Demount the device (see chapter 4.7 "Disassembly").
3. Send the device to the manufacturer.
4. Install a new device as described in the Installation Manual.
5. Setup the system as described in the Installation Manual.

Exchange of other drive system parts

If parts of the drive system (for example cables) must be replaced, proceed as follows:

1. Decommission the device (see chapter 4.5 "Decommissioning").
2. Exchange the parts.
3. Check all connections for correct fastening.
4. Setup the system as described in the Installation Manual.

4.9 Disposal

NOTICE

To dispose the unit properly, contact a certified electronic scrap disposal merchant.

In accordance with the WEEE-2012/19/EU guideline and similar, the manufacturer accepts returns of old devices and accessories for professional disposal. Transport costs are the responsibility of the sender.

Contact Kollmorgen and clarify the logistics.

Send the devices in the original packaging to the manufacturer address:

North America KOLLMORGEN 201 West Rock Road Radford, VA 24141, USA	South America KOLLMORGEN Avenida João Paulo Ablas, 2970 Jardim da Glória, Cotia – SP CEP 06711-250, Brazil
Europe KOLLMORGEN Europe GmbH Pempelfurtstr. 1 40880 Ratingen, Germany	Asia KOLLMORGEN Room 302, Building 5, Lihpao Plaza, 88 Shenbin Road, Minhang District, Shanghai, China.

5 Package

5.1 Package Supplied	28
5.2 Nameplate	28
5.3 Part Number Scheme	29

5.1 Package Supplied

When a standard drive from the AKD2G series is delivered, the following items are included in the drive package:

- AKD2G
- Printed copy of *AKD[®]2G Safety Notes*.
- DVD with WorkBench setup software .
- Panel safety label
- **ATTENTION:** Drive is ready to operate with pre-configured STO function.

NOTE

Mating connectors are **not** included in the package of a standard drive. Mating connectors are included when the drive is ordered with accessories (append “-A” to the model number).

Mating connectors listed below are never delivered with the drive. These mating connectors are usually part of the cables:

- Motor mating connector (X1, X2),
- SubD (X23, X41) for Feedback,
- RJ25 (X13, X14) for CAN Bus, and
- RJ45 (X11, X12, X20) for Service and EtherNet Fieldbus.

Accessories sold separately

Accessories must be ordered separately if required, see regional Accessories Manual.

- EMC filters for mains supply voltage, categories C2 or C3.
- External regen resistor.
- Mating connector kits.
- Motor mating connector.
- Hybrid cable. Assembled hybrid motor cables are available for all regions.
- Motor cable. Assembled motor cables are available for all regions.
- Feedback cable. Assembled feedback cables are available for all regions.
- SFA (Smart Feedback Adapter) .
- SDB Module (Safe Dynamic Brake Module).
- EtherNet service cable.

5.2 Nameplate

A nameplate is attached to the side of the drive. The picture below is similar to the nameplate on the device.

KOLLMORGEN TM Customer Support:
 North America: +1 (540) 633-3400
 Europe: +49 (0) 2102-9394-0
 Italy: +39 (0) 362-594260

201 W. Rock Road
 Radford, VA 24141

Model No: AKD2G-SPE-6V06D-A1F3-0000



Serial No: R2-1900-00000 HW Rev: A







MAC Address: 00-23-1B-00-00-00

Ratings at 40°C (See manual for ratings >40°C)		
	<i>INPUT</i>	<i>OUTPUT</i>
Voltage	120/240 Vac	0-240 Vac
Frequency	50/60 Hz	0-599Hz
Phase	1 Ph/3 Ph	3 Ph
FL Current	13/9.7 Arms	6/6 Arms
Power @ 240 Vac	3.1/4.0 KVA	

Enclosure Protection Rating: IP20

Before use, refer to CD for installation and safety information.
 Assembled in USA www.kollmorgen.com Patents, Patents Pending







5.3 Part Number Scheme

Use the part number scheme for product identification only, not for the order process, because not all combinations of features are possible.

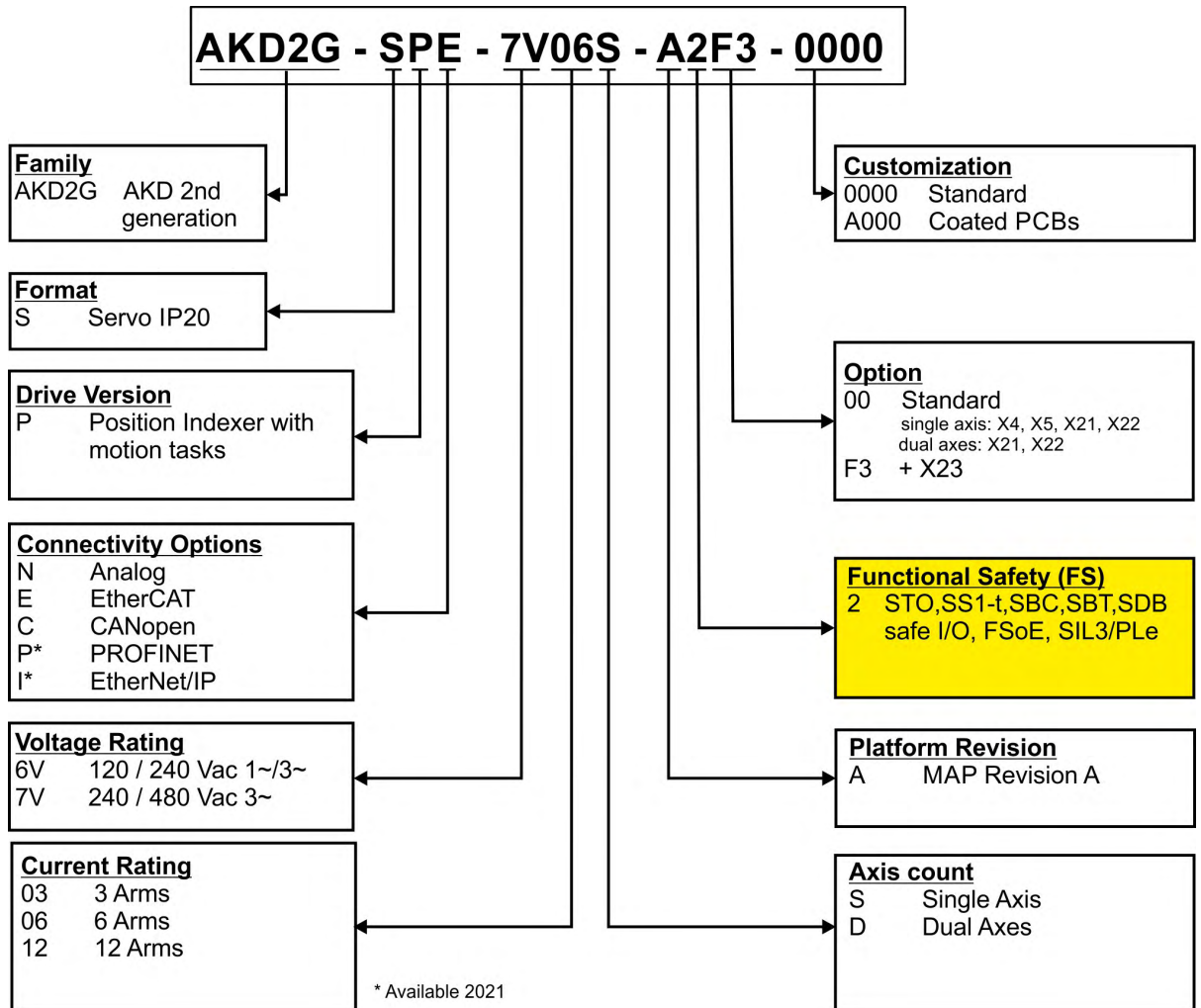
NOTE

- Mating connectors are **not** included in the package of a standard drive.
- Mating connectors are included when the drive is ordered with accessories (append “-A” to the model number).
- Mating connectors X1, X2, RJ25, RJ45, SubD are part of the used cables always.



Example AKD2G-SPE-7V06S-A2F3-0000

AKD2G IP20 housing, position indexer, EtherCAT, 240 V to 480 V mains supply, 6 A rated current, single axis, Platform Revision A, safe stop functionality SIL3 PLe with FSoE, with all possible connectors (X21, X22, X4, X5, X23), uncoated, no mating connectors.

Example AKD2G-SPE-6V06D-A2F3-A000-A

AKD2G IP20 housing, position indexer, EtherCAT, 120 V to 240 V mains supply, 2 x 6 A rated current, dual axis, Platform Revision A, safe stop functionality SIL3 PLe with FSoE, with all possible connectors (X21, X22, X23), PCBs coated, with mating connectors.

6 Technical description and data

6.1	The AKD2G Family of Digital Drives	31
6.2	Ambient Conditions, Ventilation and Mounting Position	33
6.3	Mechanical Data	33
6.4	Performance Data	34
6.5	Electrical data	35
6.6	Electrical Motor Braking	39
6.7	LCD Display and Push-buttons (B1, B2)	41
6.8	Rotary Switches (S1, S2)	43
6.9	SD Card Slot	44

6.1 The AKD2G Family of Digital Drives

Available AKD2G-SP (Position Indexer) versions

Connectivity	Rated Voltages	Current	Axis	Rev	Funct. Safety
N :- Analog C :- CANopen E :- EtherCAT P :- PROFINET I :- EtherNet/IP	6V : 120/240VAC 1~ 240VAC 3~ 170/340 VDC 7V : 240/400/480VAC 3~ 340/565/680 VDC	03 : 3 A 06 : 6 A 12 : 12 A	S :- Single D :- Dual I1=I2	A	2 : SIL3 basis

Connector Options

Single Axis	Dual Axis
00 : Basis (X21, X22, X4, X5) F3 : Basis + X23	00 : Basis (X21, X22) F3 : Basis + X23

* Available 2021

Standard features

- Single axis or dual axis in one housing
- Supply voltages:
 - DC
 - AC single phase, split phase, three phase AC neutral or leg grounded
 - Single or group supply, single or group mains fusing
- EtherNet Fieldbus on board, TCP/IP service channel and Modbus on board
- SFD3, HIPERFACE DSL motor feedback support on board
- Support for many conventional motor feedback types
- Step / Direction input on board
- Encoder emulation on board
- Use with synchronous servomotors, linear motors, and induction machines

Power section

- Single or three phase AC supply, 5% to 110% of rated AC voltage over 47 to 63 Hz. Connection to higher AC voltage mains only by using isolating transformer.
- DC supply, voltage range 5% to 110% of rated DC voltage. Fusing to be provided by the user.
- Three phase bridge rectifier, integral soft-start circuit.
- DC bus link voltage can be connected in parallel for power sharing.
- Floating current sensors measure actual motor current
- Regenerative circuit with dynamic distribution of the generated power between several drives on the same DC bus link circuit.
- Internal regen resistor for all models, optional external regen resistor if required.

Functional Safety Options

- FS2: STO, SS1-t, SBC, SBT, SDB; SIL3 PLe, command by I/O or FSoE (→ # 149).

Electrical safety

- Appropriate insulation / creepage distances and electrical isolation for safe electrical separation, per IEC 61800-5-1, between the power input / motor connections and the signal electronics.
- Soft-start, over voltage detection, short-circuit protection, phase-loss detection.
- Temperature monitoring of the drive and motor.
- Electronic motor overload protection: foldback mechanism or optional fault response.

Auxiliary supply voltage 24VDC

- From an external, safety approved 24 V \pm 10% power supply (PELV).

Parameter setting

- WorkBench Software for setup by using TCP/IP.
- Download control parameter packages by using CoE
- Download safety parameter packages by using FSoE

Full digital control

- Digital current loop (update 1.28 μ s / command 62.5 μ s)
- Digital velocity loop (update period 62.5 μ s)
- Digital position loop (update period 250 μ s)

Inputs/Outputs (X21/X22/X23)

- 2 programmable analog input (\rightarrow # 114)
- 2 programmable analog output (\rightarrow # 115)
- 12 programmable digital inputs (\rightarrow # 116)
- 4 programmable digital outputs (\rightarrow # 120)
- 6 programmable digital input/outputs (\rightarrow # 120)
- 4 programmable safe inputs (\rightarrow # 156)
- 4 programmable safe outputs (\rightarrow # 157)

Connector Options

- **F3:** X23 connector for conventional motor feedbacks (Resolver, SFD, Tamagawa Smart Abs, Comcoder, 1Vp-p Sin-Cos encoders, incremental encoders, EnDAT 2.1/2.2 and HIPERFACE).

Customization

- 0000: uncoated PCBs, standard
0xxx: uncoated PCBs, customized coding
- A000: coated PCBs, standard
Axxx: coated PCBs, customized coding

Connectivity

- Feedback inputs (\rightarrow # 94)
- Encoder emulation output (\rightarrow # 101)
- Digital Inputs/Outputs (\rightarrow # 112)
- Service Interface (\rightarrow # 110)
- Modbus Interface (\rightarrow # 111)
- CANopen (\rightarrow # 107)
- EtherNet Fieldbus interface (\rightarrow # 104)

Accessories

- **SFA** (Smart Feedback Adapter) (\rightarrow # 100).
- Hybrid motor cables, motor power cables, motor feedback cables.
- External regen resistors.

For accessories refer to your regional *Accessories Manual*.

6.2 Ambient Conditions, Ventilation and Mounting Position

Storage, Transport	(→ # 24)
Normal operation	Environmental class 3K3 according to IEC 61800-2
Surrounding temperature in operation	<p>Internal regen resistor used:</p> <ul style="list-style-type: none"> ● 0 to +40 °C under rated conditions ● +40 to +60 °C with output current derating 3 % per Kelvin <p>Internal regen resistor not used:</p> <ul style="list-style-type: none"> ● 0 to +50 °C under rated conditions ● +50 to +60 °C with output current derating 2 % per Kelvin
Humidity in operation	Relative humidity 5 to 85%, no condensation, IEC 61800-2 class 3K3
Site altitude	<ul style="list-style-type: none"> ● Up to 1,000 m AMSL (above mean sea level): no restriction ● 1,000 to 2,000 m AMSL: power derating 1.5%/100 m ● Maximum altitude: 2,000 m AMSL
Pollution level	Pollution level 2 as per IEC 60664-1
Vibration	Class 3M1 according to IEC 61800-2
Shock	Class L according to IEC 61800-2
Drive protection	IP 20 according to IEC 60529
Drive EMC immunity	Increased immunity according to EN 61800-5-2
Mounting	Vertical position, in a cabinet with protection of at least IP 54 Minimum cabinet size (WxHxD): 406 x 406 x 254 mm
Ventilation	Built-in fan in all drive variants
NOTICE	The drive shuts down in case of excessively high temperature in the control cabinet. Make sure sufficient forced ventilation is supplied within the control cabinet.

6.3 Mechanical Data

	Units	AKD2G-Sxx-			
		6V03S, 6V06S, 6V12S	6V03D, 6V06D	7V03S, 7V06S	7V03D, 7V06D, 7V12S
Weight	kg	2.4	2.5	2.5	2.7
Width	mm	76	76	75	75
Height, without connectors	mm	235	235	272	272
Height, with connectors	mm	303	303	340	340
Depth, without connectors	mm	221	221	221	221
Depth, with connectors	mm	232	232	232	232

NOTE

Dimension Drawing see section Mechanical Installation (→ # 45).

6.4 Performance Data

Performance Data	Units	AKD2G-Sxx-			
		6V03S/D 6V06S/D 6V12S	7V03S/D 7V06S	7V06D	7V12S
Normal PWM Switching Frequency (dynamic)	kHz	15	11	9.8	9.8
High Load PWM Switching Frequency (dynamic)	kHz	10.3	8.1	6.5	5.9
High Load Stalled PWM Switching Frequency (dynamic)	kHz	5.2	4.1	3.5	3.5
Voltage rise speed dU/dt	kV/μs	7.0	7.0	7.0	7.0
Current Loop Update Period	μs	1.28*	1.28*	1.28*	1.28*
Velocity Loop Update Period	μs	62.5	62.5	62.5	62.5
Position Loop Update Period	μs	250	250	250	250
Current Loop Bandwidth	Hz	3000	3000	3000	3000
Velocity Loop Bandwidth	Hz	750	750	750	750
Position Loop Bandwidth	Hz	350	350	350	350
Max. motor electrical frequency	Hz	599	599	599	599

* Control updates every 1.28 μs. Current command is updated every 62.5 μs.

6.5 Electrical data

6.5.1 Single axis variants (S)

6.5.1.1 Mains supply data, 1 phase AC, type AKD2G-Sxx- (S)

Input data	Units	6V03S	6V06S	6V12S
Operational supply voltage (line-line)	VAC	12 to 265		
Rated supply voltage	VAC	240		
Rated supply input frequency ($\pm 5\%$)	Hz	50 to 60		
Permitted switch on/off frequency	1/h	30		
Rated input VA at 240 V	kVA	1.0	1.7	3.1
Rated input current	A	4.0	7.1	13
Max. inrush current	A	10		
Rated DC bus link voltage	VDC	300		

6.5.1.2 Mains supply data, 3 phase AC, type AKD2G-Sxx- (S)

Input data	Units	6V03S	6V06S	6V12S	7V03S	7V06S	7V12S
Operational supply voltage (L1/L2/L3)	VAC	12 to 265			24 to 525		
Rated supply voltage	VAC	240			480		
Rated supply input frequency ($\pm 5\%$)	Hz	50 to 60					
Permitted switch on/off frequency	1/h	30					
Rated input VA at 240 V (* at 480 V)	kVA	1.3	2.2	4.0	2.7*	4.4*	7.2*
Rated input current	A	3.2	5.3	9.7	3.2	5.3	8.7
Max. inrush current	A	10					
Rated DC bus link voltage	VDC	310			620		

6.5.1.3 Mains supply data, DC, type AKD2G-Sxx- (S)

Input data	Units	6V03S	6V06S	6V12S	7V03S	7V06S	7V12S
Operational supply voltage (DC+/DC-)	VDC	17 to 370			34 to 740		
Rated supply voltage	VDC	340			680		
Permitted switch on/off frequency	1/h	30					
Rated input power at 340 V (* at 680 V)	kW	0.62	1.25	2.5	1.25*	2.5*	5.0*
Rated input current	A	2.0	4.0	8.0	2.0	4.0	8.0
Max. inrush current through AC input	A	10					
Rated DC bus link voltage	VDC	340			680		

6.5.1.4 Auxiliary voltage input data, 24VDC, type AKD2G-Sxx- (S)

Input data	Units	6V03S	6V06S	6V12S	7V03S	7V06S	7V12S
Aux. voltage supply (PELV)	VDC	24 V ($\pm 10\%$, check voltage drop)					
- control current without motor brake	A	< 1.0					
- control current with one motor brake	A	< 3.1					
- control current with two motor brakes	A	< 5.2					

6.5.1.5 Output data, type AKD2G-Sxx- (S)

	Units	6V03S	6V06S	6V12S	7V03S	7V06S	7V12S
Continuous output current (± 3%)	Arms	3	6	12	3	6	12
Peak output current (for 5s, ±3%)	Arms	9	18	30	9	18	30
Continuous motor shaft output power at rated input current							
at 1 x 120 VAC	kW	0.22	0.44	0.875	-	-	-
at 1 x 240 VAC	kW	0.44	0.875	1.8	-	-	-
at 3 x 120 VAC	kW	0.31	0.625	1.25	-	-	-
at 3 x 240 VAC	kW	0.625	1.25	2.5	0.625	1.25	2.5
at 3 x 400 VAC	kW	-	-	-	1.05	2.1	4.2
at 3 x 480 VAC	kW	-	-	-	1.25	2.5	5.0
at 170 VDC	kW	0.31	0.625	1.25	-	-	-
at 340 VDC	kW	0.625	1.25	2.5	0.625	1.25	2.5
at 565 VDC	kW	-	-	-	1.05	2.1	4.2
at 680 VDC	kW	-	-	-	1.25	2.5	5.0
Peak output power (for 1 s)							
at 1 x 120 VAC	kW	1.1	2.1	4.1	-	-	-
at 1 x 240 VAC	kW	2.1	4.2	6.3	-	-	-
at 3 x 120 VAC	kW	1.5	3	4.5	-	-	-
at 3 x 240 VAC	kW	3.0	6.0	9.0	3.0	6.0	10
at 3 x 400 VAC	kW	-	-	-	5.0	10	16.5
at 3 x 480 VAC	kW	-	-	-	6.0	12	20
at 170 VDC	kW	1.5	3	4.5	-	-	-
at 340 VDC	kW	3.0	6.0	9.0	3.0	6.0	10
at 565 VDC	kW	-	-	-	5.0	10	16.5
at 680 VDC	kW	-	-	-	6.0	12	20
Noise emission at 1 m, low/high speed fan	dB(A)	< 50 / 60					
Thermal dissipation, disabled	W	12	12	12	12	12	12
Thermal dissipation at rated current	W	50	80	140	65	105	210
Motor inductance							
minimum at 120 VAC	mH	1.2	0.6	0.3	-	-	-
minimum at 240 VAC	mH	2.4	1.2	0.6	3.1	1.5	1.1
minimum at 400 VAC	mH	-	-	-	5.1	2.6	1.8
minimum at 480 VAC	mH	-	-	-	6.1	3.1	2.1
maximum	mH	240	120	60	610	310	210
Regeneration Braking	(→ # 39)						
Brake output							
Voltage (±10%)	VDC	24					
Voltage power saving	VDC	12 to 24					
Output under current fault	mA	100 (required for fault detection)					
Output over current fault	A	2.25 (required for fault detection)					
Output current, maximum	A	2.1					

6.5.2 Dual axis variants (D: I1=I2)

6.5.2.1 Mains supply data, 1 phase AC, type AKD2G-Sxx- (D)

Input data	Units	6V03D	6V06D
Operational supply voltage (line-line)	VAC	12 to 265	
Rated supply voltage	VAC	240	
Rated supply input frequency ($\pm 5\%$)	Hz	50 to 60	
Permitted switch on/off frequency	1/h	30	
Rated input VA at 240 V	kVA	1.7	3.1
Rated input current	A	7.2	13
Max. inrush current	A	10	
Rated DC bus link voltage	VDC	300	

6.5.2.2 Mains supply data, 3 phase AC, type AKD2G-Sxx- (D)

Input data	Units	6V03D	6V06D	7V03D	7V06D
Operational supply voltage (L1/L2/L3)	VAC	12 to 265		24 to 525	
Rated supply voltage	VAC	240		480	
Rated supply input frequency ($\pm 5\%$)	Hz	50 to 60			
Permitted switch on/off frequency	1/h	30			
Rated input VA at 240 V (* at 480 V)	kVA	2.2	4.0	4.4*	7.2*
Rated input current	A	5.3	9.7	5.3	8.7
Max. inrush current (at 240 V/480 V, 20°C)	A	10			
Rated DC bus link voltage	VDC	310		620	

6.5.2.3 Mains supply data, DC, type AKD2G-Sxx- (D)

Input data	Units	6V03D	6V06D	7V03D	7V06D
Operational supply voltage (DC+/DC-)	VDC	17 to 370		34 to 740	
Rated supply voltage	VDC	340		680	
Permitted switch on/off frequency	1/h	30			
Rated input power at 340 V (* at 680 V)	kW	1.25	2.5	2.5*	5*
Rated input current	A	4	8	4	8
Max. inrush current through AC input	A	10			
Rated DC bus link voltage	VDC	340		680	

6.5.2.4 Auxiliary voltage input data, 24VDC, type AKD2G-Sxx- (D)

Input data	Units	6V03D	6V06D	7V03D	7V06D
Aux. voltage supply (PELV)	VDC	24 V ($\pm 10\%$, check voltage drop)			
- current without motor brake	A	<1			
- control current with one motor brake	A	<3.1			
- control current with two motor brakes	A	<5.2			

6.5.2.5 Output data, type AKD2G-Sxx- (D)

Drive current and power output values are listed for Axis1/Axis2.

	Units	6V03D	6V06D	7V03D	7V06D
Continuous output current (± 3%)	Arms	3/3	6/6	3/3	6/6
Peak output current (for 5s, ±3%)	Arms	9/9	18/18	9/9	18/18
Continuous motor shaft output power at rated input current					
at 1 x 120 VAC	kW	0.22/0.22	0.44/0.44	-	-
at 1 x 240 VAC	kW	0.44/0.44	0.875/0.875	-	-
at 3 x 120 VAC	kW	0.31/0.31	0.625/0.625	-	-
at 3 x 240 VAC	kW	0.625/0.625	1.25/1.25	0.625/0.625	1.25/1.25
at 3 x 400 VAC	kW	-	-	1.05/1.05	2.1/2.1
at 3 x 480 VAC	kW	-	-	1.25/1.25	2.5/2.5
at 170 VDC	kW	0.31/0.31	0.625/0.625	-	-
at 340 VDC	kW	0.625/0.625	1.25/1.25	0.625/0.625	1.25/1.25
at 565 VDC	kW	-	-	1.05/1.05	2.1/2.1
at 680 VDC	kW	-	-	1.25/1.25	2.5/2.5
Peak output power (for 1 s)					
at 1 x 120 VAC	kW	1.1/1.1	2.1/2.1	-	-
at 1 x 240 VAC	kW	2.1/2.1	4.2/4.2	-	-
at 3 x 120 VAC	kW	1.5/1.5	3.0/3.0	-	-
at 3 x 240 VAC	kW	3.0/3.0	6.0/6.0	3.0/3.0	6.0/6.0
at 3 x 400 VAC	kW	-	-	5.0/5.0	10/10
at 3 x 480 VAC	kW	-	-	6.0/6.0	12/12
at 170 VDC	kW	1.5/1.5	3.0/3.0	-	-
at 340 VDC	kW	3.0/3.0	6.0/6.0	3.0/3.0	6.0/6.0
at 565 VDC	kW	-	-	5.0/5.0	10/10
at 680 VDC	kW	-	-	6.0/6.0	12/12
Noise emission at 1 m, low/high speed fan	dB(A)	< 50 / 60			
Thermal dissipation, disabled	W	15	15	15	15
Thermal dissipation at rated current	W	90	150	120	210
Motor inductance					
minimum at 120 VAC	mH	1.2/1.2	0.6/0.6	-	-
minimum at 240 VAC	mH	2.4/2.4	1.2/1.2	3.1/3.1	1.9/1.9
minimum at 400 VAC	mH	-	-	5.1/5.1	3.2/3.2
minimum at 480 VAC	mH	-	-	6.1/6.1	3.8/3.8
maximum	mH	240/240	120/120	610/610	380/380
Regeneration Braking		(→ # 39)			
Brake output					
Voltage (±10%)	VDC	24			
Voltage power saving	VDC	12 to 24			
Output under current fault	mA	100 (required for fault detection)			
Output over current fault	A	2.25 (required for fault detection)			
Output current, maximum	A	2.1 per brake			

6.6 Electrical Motor Braking

6.6.1 Drive Dynamic Braking

Drive Dynamic braking is a method to slow down a servo system by dissipating the mechanical energy driven by the motor back EMF.

NOTE

Drive dynamic braking is not functional safe. Safe dynamic braking (SDB) requires an external SDB module (→ # 185).

The AKD2G has a built in advanced drive dynamic braking mode which operates fully in hardware. When activated, the drive powers the motor terminals with voltages to maximize the stopping force per amount of motor current. This advanced method forces all of the dynamic braking current to be stopping current and insures the fastest stopping per ampere of motor terminal current.

- When current is not being limited, the mechanical energy is being dissipated in the motor winding resistance.
- When current is being limited, energy is returned to the drive bus capacitors.
- The drive also limits the maximum dynamic braking motor terminal current by using the *AXIS#.DBLIMIT* parameter to insure that the drive, motor, and customer load do not see excessive currents/forces.

Whether and how the AKD2G uses dynamic drive braking depends on (*AXIS#.DISMODE*).

6.6.2 Regeneration braking

When the amount of returned energy from the motor builds the bus capacitor voltage up enough the drive activates the regenerative braking circuit to start dumping the returned energy in the regen resistor (also called regenerative resistor or brake resistor). All AKD2G offer internal resistor plus the ability to connect an external resistor depending on the application requirements.

NOTE

External regen resistors are described in the regional *Accessories Manual*.

6.6.2.1 Functional description

1. Individual drives, not coupled through the DC bus link circuit (+DC, -DC)

When the energy fed back from the motor has an average or peak power that exceeds the preset level for the brake power rating, the drive generates the warning "W2010 Regen Energy Critical". If the power exceeds the set fault level, the regenerative circuit will switch off and the drive will disable.

2. Several drives coupled through the DC bus link (+DC, -DC)

Using the built-in regenerative circuit, several drives of the same series can be operated from a common DC-bus link (→ # 82), without any additional measures. 90% of the combined power of all the coupled drives is always available for peak and continuous power. If the power of the drive with the lowest switch-off threshold (resulting from tolerances) exceeds the set fault level, the regenerative circuit will switch off on that drive.

Switch-off on over voltage: With the regenerative circuit switched off, the returned energy is not dissipated and therefore the DC-bus link level increases. The drive reports an over-voltage fault if the DC-bus voltage threshold is exceeded. When this happens, the drive power stage is immediately disabled and the load coasts to a stop with the fault message "F2006 Bus Over voltage".

The ready to operate contact (terminals X21/B5-B6) is opened (→ # 123).

NOTE

Observe the regeneration time (some minutes) after full load with peak brake power.

6.6.2.2 Technical data for AKD2G-Sxx-6V

Technical data for the regenerative circuit depends on the drive type and the mains voltage. Supply voltages, capacitance, and switch-on voltages are all nominal values.

Brake circuit AKD2G-Sxx-		Units	AC Supply 120V / 240V	
	Rated data			
6Vxxy all types	Regen start voltage at rated supply voltage	V	380	
	Overvoltage limit	V	420	
	Maximum regenerative duty cycle	%	35*	
	Internal regen resistor	Ω	15	
	Continuous power, internal resistor	W	100	
	Peak brake power, internal resistor (0.5s)	kW	3 / 9	
	External regen resistor (recommended 15 Ω)	Ω	>10	
	Continuous brake power, external resistor	kW	3	
	Peak brake power, external (1s)	kW	5 / 14	
6V03S, 6V06S	Absorption energy in capacitors (±20%)	Ws	6 / 23	
	DC Bus Capacitance	μF	1640	
6V12S, 6V03D, 6V06D	Absorption energy in capacitors (± 20%)	Ws	9 / 35	
	DC Bus Capacitance	μF	2460	

* depends on connected regen resistor power.

6.6.2.3 Technical data for AKD2G-Sxx-7V

Technical data for the regenerative circuit depends on the drive type and the mains voltage. Supply voltages, capacitance, and switch-on voltages are all nominal values.

Brake circuit AKD2G-Sxx-		Units	AC Supply 240V 400V/480V	
	Rated data			
7V03S ,7V06S, 7V12S, 7V03D, 7V06D	Regen start voltage at rated supply voltage	V	380	633 / 760
	Overvoltage limit	V	420	840
	Maximum regenerative duty cycle	%	35*	
	Internal regen resistor	Ω	33	
	Continuous power, internal resistor	W	100	
	Peak brake power, internal resistor (0.5s)	kW	4	17
	External regen resistor (recommended 33 Ω)	Ω	>25	
	Continuous brake power, external resistor	kW	2	6
	Peak brake power, external (1s)	kW	6	24
7V03S, 7V06S	Absorption energy in capacitors (±20%)	Ws	3	30 / 18
	DC Bus Capacitance	μF	235	
7V12S, 7V03D, 7V06D	Absorption energy in capacitors (±20%)	Ws	6	50 / 35
	DC Bus Capacitance	μF	470	

* depends on connected regen resistor power.

6.7 LCD Display and Push-buttons (B1, B2)

The drive offers an LCD display and two push-buttons B1 / B2 for navigation.

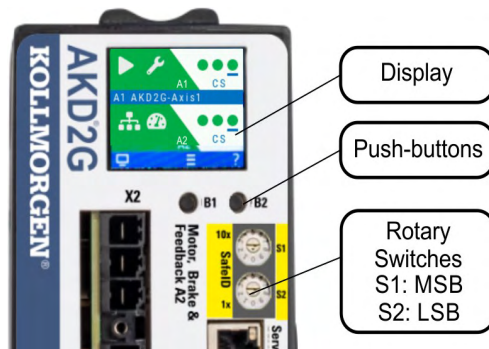

Push-button actions

A short button press invokes the action corresponding to the symbol directly above the button. On the dashboard for example,

- a short press on B1 causes the menu system to appear, and
- a short press on B2 causes a help screen to appear.
- A long press (greater than 2 seconds) on B2 returns the display to the previous screen.

B1 / B2 Functions	Description
Boot from SD card	Push both buttons during power up to boot with data from SD card. Press the buttons first, then hold it down while turning on the 24 V power supply.
Boot from flash fall-back image	Remove the SD card, then press both buttons and hold them down while turning on the 24 V power supply to boot from an on-board recovery image. The fallback image includes a set of boot-loader, operational, and control FPGA that implements sufficient programming support to update missing or corrupt files.
SafeID Validation	Push B2 to acknowledge SafeID validation request on the display.

LCD display

- Left Colored section
 - Color: axis status (enabled, disabled, or faulted).
 - First icon: axis command source (analog, service, electronic gearing, or fieldbus).
 - Second icon: axis operation mode (torque, velocity, or position).
 - Axis ID: A1 or A2.
- Right Non-colored section:
 - No Fault/Warning: three virtual LEDs corresponding to axis disable sources (Safe Torque Off, Hardware Enable, and Controlled Stop).
 - Faults or warnings: fault or warning code.
- Center blue bar:
 - Drive and axis names
 - IP address
 - Drive model number
 - Firmware version
- Bottom blue bar:
 - indicates whether the service port is connected to WorkBench, and
 - shows the actions that will be invoked by pushing the B1 / B2 buttons.

Dual axis LCD display

For dual-axis drives, the top section shows axis 1 information, the bottom section those for axis 2.

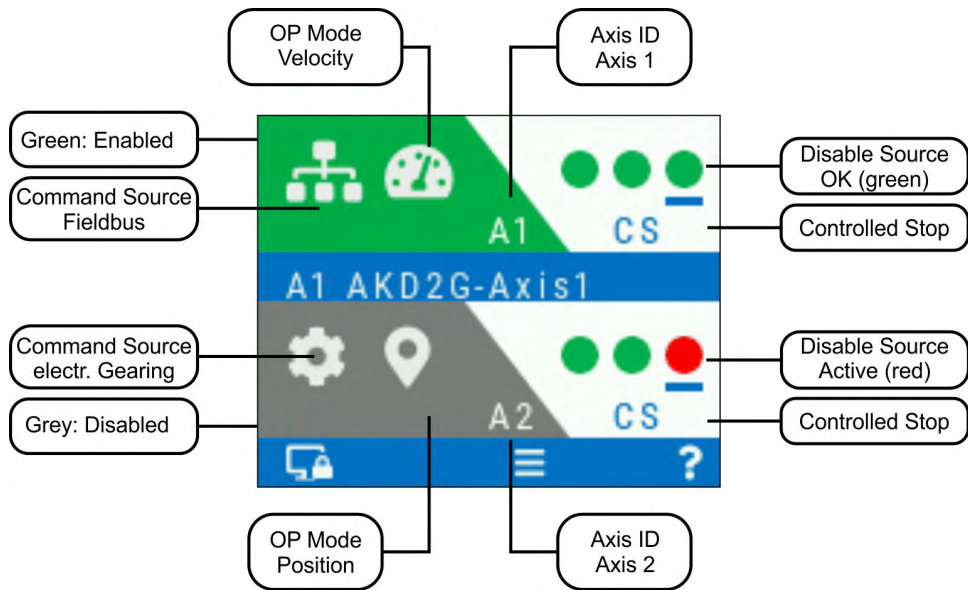

Single axis LCD display

For single axis drives, the top section shows axis 1 information while the section between the center and bottom bars is a data area where some important actual values of the axis are visible: position, velocity, current.

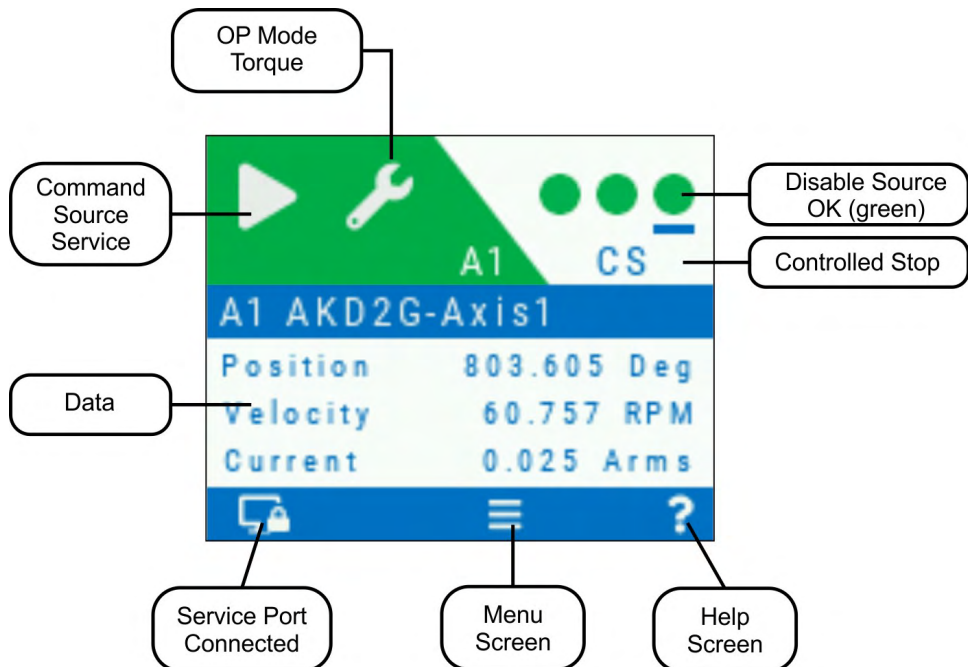

Faults and Warnings

The display shows the code of the fault or warning that occurred. If a fault occurs, the color of the left section switches to red. Navigate with B1 / B2 to the Fault screen to see a short description of the fault or warning.

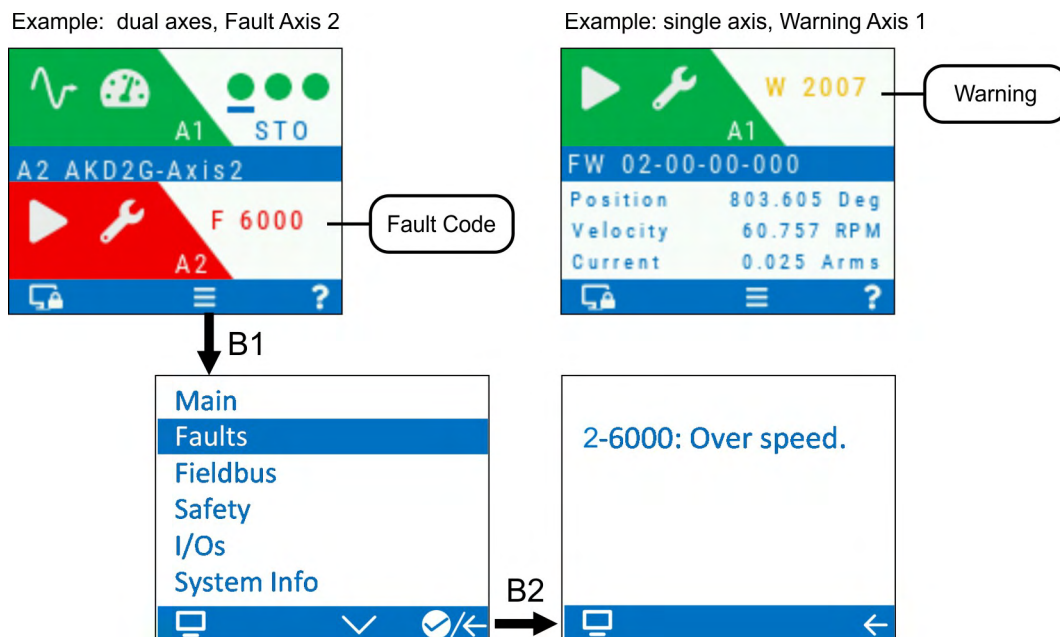

See WorkBench Onlinehelp for more details.

6.8 Rotary Switches (S1, S2)

AKD2G with safety option 2 offer two decimal rotary switches for setting the SafeID and FSoE node address.

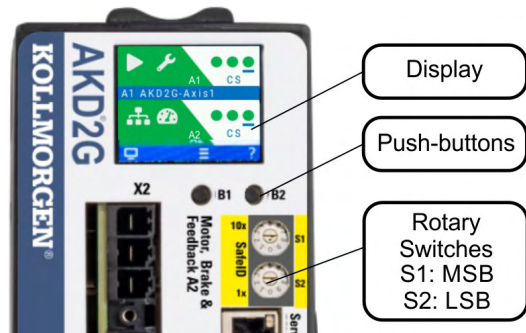

Refer to section "Functional Safety" for complete information (→ # 190).

6.9 SD Card Slot



AKD2G offer a SD card slot

- to boot the drive with data from the SD Memory card

These features can be started from the drive display using push-buttons B1/B2.

Supported SD card types

SD cards are formatted by the manufacturer. The following table outlines the SD card types and AKD2G support.

SD Type	File System	Capacity	Supported
SD (SDSC)	FAT16	1MB to 2GB	YES
SDHC	FAT32	4GB to 32GB	YES
SDXC	exFAT (Microsoft)	>32GB to 2TB	NO

Features

- **Boot AKD2G with data from SD card:**
Remove 24V. Apply 24V with buttons B1 and B2 pressed. Release buttons after the display is updated.

7 Mechanical Installation

7.1 Important Notes	46
7.2 Guide to Mechanical Installation	46
7.3 Dimensions	47

7.1 Important Notes



CAUTION High EMC Voltage Level!

Risk of electrical shock, if the servo amplifier (or the motor) is not properly EMC-grounded.

- Do not use painted (i.e. non-conductive) mounting plates.
- In unfavourable circumstances, use copper mesh tape between the earthing bolts and earth potential to deflect currents.

NOTICE

Protect the drive from impermissible stresses. In particular, do not let any components become bent or any insulation distances altered during transport and handling. Avoid contact with electronic components and contacts.

NOTICE

The drive will switch itself off in case of overheating. Ensure that there is an adequate flow of cool, filtered air into the bottom of the control cabinet, or use a heat exchanger (→ # 33).

NOTICE

Do not mount devices that produce magnetic fields directly beside the drive. Strong magnetic fields can directly affect internal components. Install devices which produce magnetic field with distance to the drives and/or shield the magnetic fields.

7.2 Guide to Mechanical Installation

The following tools are required (at a minimum) to install the AKD2G; your specific installation may require additional tools:

- M5 hexagon socket-cap screws (ISO 4762)
- 4 mm hexagon ball head screwdriver
- No. 2 Phillips head screwdriver
- Small slotted screwdriver

Install the drive unit as follows:

1. Prepare the site.
Mount the drive in a closed control cabinet (ambient conditions (→ # 33)). The site must be free from conductive or corrosive materials. For the mounting position in the cabinet (→ # 47).
2. Check ventilation.
Check that the ventilation of the drive is unimpeded, and keep within the permitted ambient temperature (→ # 33). Keep the required space clearance above and below the drive (→ # 47).
3. Check the cooling system.
If cooling systems are used for the control cabinet, position the cooling system so that condensation water cannot drip onto the drive or peripheral devices.
4. Mount the drive.
Assemble the drive and power supply near each other on the conductive, grounded mounting plate in the cabinet.
5. Ground the drive.
For EMC-compliant shielding and grounding, (→ # 55). Ground the mounting plate, motor housing and CNC-GND of the control system.

7.3 Dimensions

NOTE

Mounting: 3 x M5 hexagon socket screws to ISO 4762, 4 mm hexagon ball head screw-driver

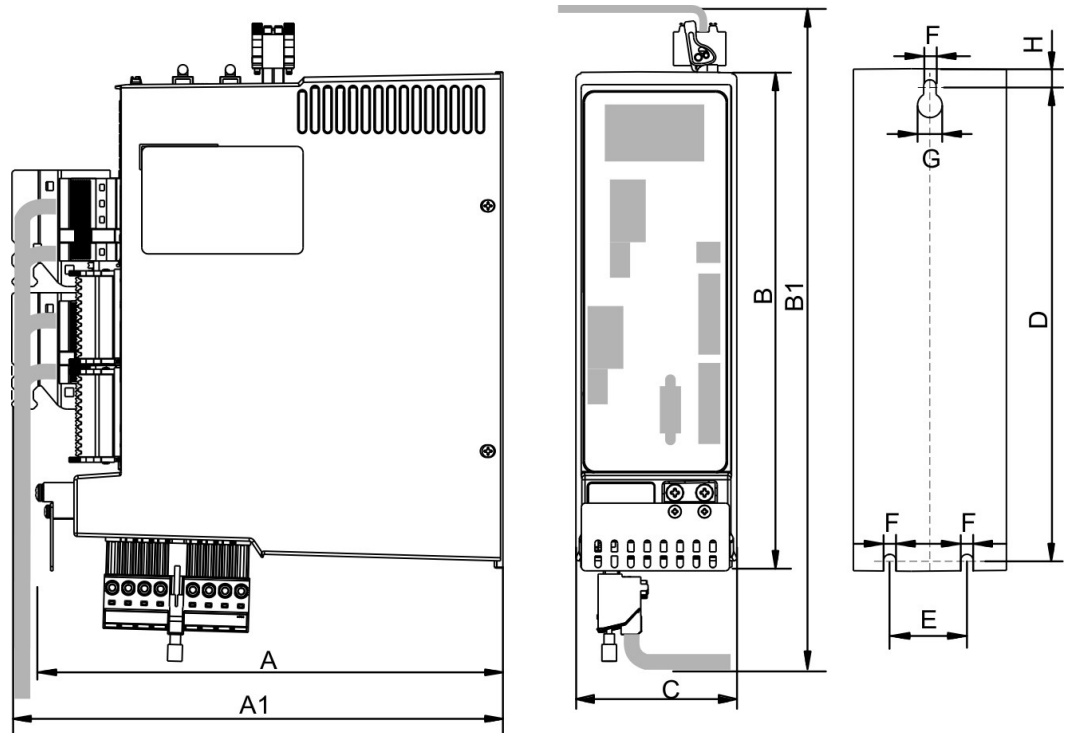

NOTE

Outline width and height dimensions are measured on footprint level (mounting plate). Dimensions on the front plate are slightly smaller. All dimensions in mm.

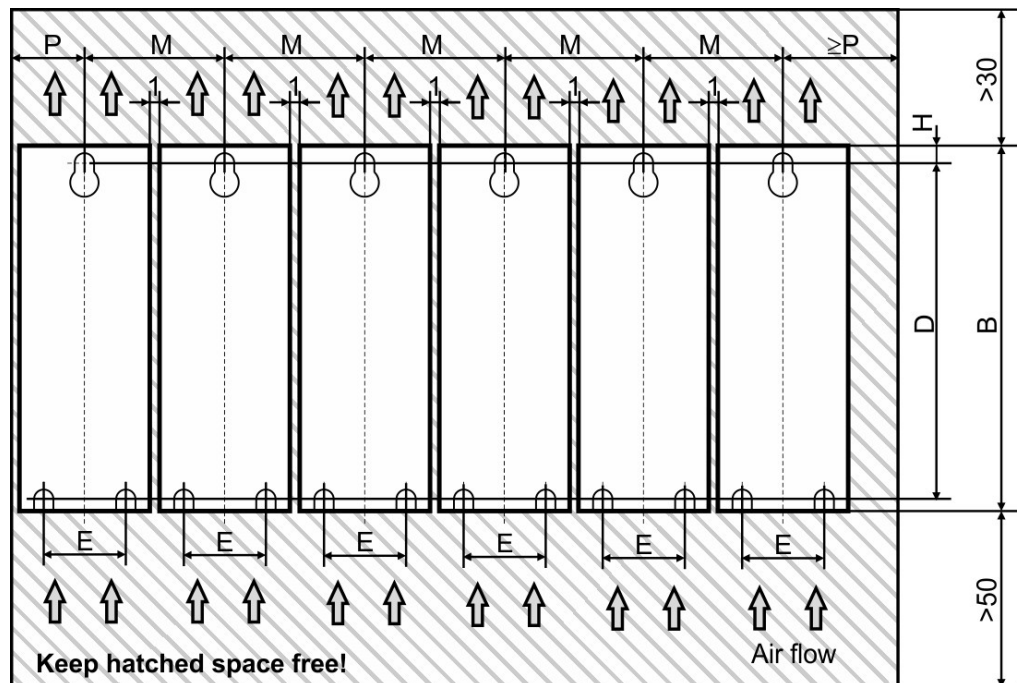

Dimensions in mm	A	A1	B	B1	C	D	E	F	G	H	M	P
AKD2G-Sxx-6V (3 to 12 A)	221	232	235	303	76	221,5	36	5,8	11,5	7	78	40
AKD2G-Sxx-7V (3 to 12 A)	221	232	272	340	75	259	36	5,8	11,5	6	78	40

8 Electrical Installation

8.1 Important Notes	49
8.2 Guide to electrical installation	50
8.3 Wiring	51
8.4 EMI Noise Reduction	55
8.5 Connection Overview	60
8.6 Power and Logic Voltage Supply (X3/X10)	73
8.7 DC Bus link connector X3	82
8.8 Regen resistor connector X3	84
8.9 Motor Power, Brake and Feedback connection	84
8.10 EEO, Electronic Gearing, Master-Slave	101
8.11 EtherNet Fieldbus Interface connector X11/X12	104
8.12 CAN-Bus Interface connector X13/X14	107
8.13 Service Interface connector X20	110
8.14 Modbus TCP connector X20	111
8.15 I/O Connectors X21/X22/X23	112

8.1 Important Notes

NOTICE

Only professional staff who are qualified in electrical engineering are allowed to install the drive. Wires with color green with one or more yellow stripes must not be used other than for protective earth (PE) wiring.



⚠ DANGER High Voltage up to 900 V!

There is a danger of serious personal injury or death by electrical shock or electrical arcing. Capacitors can still have dangerous voltages present up to 5 minutes after switching off the supply power. Control and power connections can still be live, even if the motor is not rotating.

- Only install and wire the equipment when it is not live.
- Make sure that the cabinet is safely disconnected (for instance, with a lock-out and warning signs).
- Never remove electrical connections to the drive while it is live.
- Wait at least 5 minutes after disconnecting the drive from the main supply power before touching potentially live sections of the equipment (e.g. contacts) or undoing any connections.
- To be sure, measure the voltage in the DC bus link and wait until it has fallen below 50 V.

NOTICE

Wrong mains voltage, unsuitable motor or wrong wiring will damage the drive. Check the combination of drive and motor. Compare the rated voltage and current of the units. Implement the wiring according to the matching connection diagram, see (→ # 64) and following.

Make sure that the maximum permissible rated voltage at the terminals L1, L2, L3 or +DC, –DC is not exceeded by more than 10% even in the most unfavorable circumstances (see IEC 60204-1).

NOTICE

Excessively high external fusing will endanger cables and devices. The fusing of the mains power and logic power must be installed by the user. Hints for use of Residual-current circuit breakers (RCD) (→ # 20).

NOTICE

Since the leakage current to PE is more than 3.5 mA, in compliance with IEC61800-5-1 the PE connection must either be doubled or a connecting cable with a cross-section >10 mm² must be used. Deviating measures according to regional standards might be possible.

NOTICE

The drive status shall be monitored by the PLC to acknowledge critical situations. We recommend wiring the ready to operate relay contact in series into the emergency off circuit of the installation. The emergency off circuit must operate the supply contactor.

NOTE

It is permissible to use the setup software to alter the settings of the drive. Any other alterations will invalidate the warranty.

8.2 Guide to electrical installation

Kollmorgen recommends to install the drive electrical system as follows:

1. Select cables in accordance with IEC 60204 (→ # 52).
2. Install shielding and ground the drive.
For EMC-compliant shielding and grounding, see (→ # 55).
Ground the mounting plate, motor housing and CNC-GND of the control system.
3. For functional safety information, see (→ # 142).
4. Wire the drive and connectors.
Observe the "Recommendations for EMI noise reduction": (→ # 55).
 - Wire the "Ready to Operate" contact into the emergency off circuit of the system.
 - Connect the digital control inputs and outputs.
 - Connect up analog ground (also if a fieldbus is used).
 - Connect the analog input source, if required.
 - Connect the motor (hybrid cable or power, brake and feedback cables).
 - Connect shielding at both ends.
 - If required, connect the external regen resistor (with fusing).
 - AKD2G-Sxx-6V: connect EMC filters (shielded lines between filter and drive) for second environment requirements to product category C2.
 - Connect the auxiliary voltage supply
 - Connect the main electrical supply.
Check maximum permitted voltage value (→ # 35).
 - Check proper use of residual-current circuit breakers (RCD): (→ # 20).
 - Connect the PC (→ # 110) for setting up the drive.
5. Check the wiring against the wiring diagrams:
 - Overview AKD2G single axis (→ # 64)
 - Overview AKD2G dual-axis (→ # 65)
 - Connector pinout (→ # 66) ff
 - Mains power supply: (→ # 74) ff
 - Logic power supply: (→ # 81)
 - DC Bus Link: (→ # 82)
 - External Regen Resistor: (→ # 84)
 - Motor single cable connection: (→ # 85)
 - Motor dual cable connection: (→ # 88)
 - Motor Holding Brake: (→ # 91)
 - Feedback Connection (→ # 94)
 - Encoder emulation: (→ # 101)
 - Electronic gearing: (→ # 103)
 - Master Slave: (→ # 103)
 - EtherNet Fieldbus interface: (→ # 104)
 - CAN-Bus interface: (→ # 107)
 - Service interface: (→ # 110)
 - Modbus interface: (→ # 111)
 - Digital and analog I/O: (→ # 112)
 - Functional Safety option 2: (→ # 149)

8.3 Wiring

NOTICE

Only professional staff who are qualified in electrical engineering are allowed to install the drive. Wires with color green with one or more yellow stripes must not be used other than for protective earth (PE) wiring. When installing or replacing cables, use only standardized components, which complies to the cable and wire requirements (→ # 52).

8.3.1 General



DANGER High Voltage up to 900 V!

There is a danger of serious personal injury or death by electrical shock or electrical arcing.

- Only install and wire the equipment when it is not live, that is, when neither the electrical supply nor the 24 V auxiliary voltage nor the supply voltages of any other connected equipment is switched on.
- Make sure that the cabinet is safely disconnected (for instance, with a lock-out and warning signs). The individual voltages are switched on for the first time during setup.

NOTE

The chassis ground symbol, which is used in all the wiring diagrams, indicates that you must take care to provide an electrically conductive connection with the largest feasible surface area between the unit indicated and the mounting plate in the control cabinet. This connection is for the effective grounding of HF interference, and must not be confused with the PE-symbol (PE = protective earth, safety measure as per IEC 60204).

8.3.2 Mating connectors

NOTE

- Connectors X1, X2, X4, X5, X10T, X21, X22 are spring clamp connectors.
- X3/X3T connector with screw terminals, tightening torque 0.5...0.6 Nm (4.4...5.3 inlbs).
- Connectors X4, X5, X22 and X23 are optional.

#	Description	Type	Max. Cross Section
X1/2	Motor, two wire feedback, holding brake	Connector, 4 pol. power	10 mm ² , 8 awg
		Connector, 4 pol. signal	0.5 mm ² , 21 awg
X3/X3T	Mains power, regen resistor, DC-Bus	Connector or T-type, 8 pol.	6 mm ² , 10 awg
X4	Second Brake	Connector, 3 pol.	1.5 mm ² , 16 awg
X5	Second feedback, two wire	Connector, 3 pol.	1.5 mm ² , 16 awg
X10T	24V power supply	T-type connector, 2 pol.	2.5 mm ² , 14 awg
X11/12	EtherNet Fieldbus	RJ45	0,5 mm ² , 21 awg
X13/14	CAN In/Out	RJ25	0,5 mm ² , 21 awg
X20	Service Port	RJ45	0,5 mm ² , 21 awg
X21	I/O control signals	Connector, 2x11 pol.	1.5 mm ² , 16 awg
X22	I/O control signals	Connector, 2x10 pol.	1.5 mm ² , 16 awg
X23	Conventional feedback models	SubD 15pol. HD (female)	0,5 mm ² , 21 awg

8.3.3 Cable and Wire Requirements

8.3.3.1 Cable material

For information on the chemical, mechanical, and electrical characteristics of the cables please refer to the *Kollmorgen 2G Cable Guide* or contact customer support.

NOTE To reach the maximum permitted cable length, you must use cable material with the following capacitance requirements:

- Motor power cable: less than 150 pF/m (phase core to shield capacitance)
- Motor Feedback cable: less than 120 pF/m (signal core to shield capacitance)
- Hybrid motor cable:
 - less than 120 pF/m (phase core/core capacitance)
 - less than 210 pF/m (phase core/shield capacitance)
 - less than 120 pF/m (signal core/core capacitance)
 - less than 210 pF/m (signal core/shield capacitance)
 - BUS Element: 45 pF/m @ 800kHz & charact. wave resistance $110 \pm 10 \Omega @ 10\text{MHz}$

8.3.3.2 Cable Length

NOTICE Cables should not exceed the maximum lengths stated below. The recommended maximum cable length of motor cables depends on the used cable material and the feedback type. Cable functionality is only guaranteed up to the maximum length when using unmodified Kollmorgen engineered cables.

Motor cables (X1, X2, X4, X5, X23, X41)

Length of motor power cables, feedback cables and motor brake cables is equal.

AKM2G		AKM			
Performance Line Cables		Performance Line Cables		Value Line Cables	
Feedback	Max. Length [m]	Feedback	Max. Length [m]	Feedback	Max. Length [m]
SFD3	50	All	25	All	12
DSL	25				
Endat 2.2	25				
Resolver	50				

I/O cables (X21, X22)

NOTICE Maximum distance for unshielded I/O lines is 3 m inside the cabinet. If the I/O cable leaves the cabinet, it must be EMC shielded.

8.3.3.3 T-Connector wiring

If you use mating T-connectors for 24 VDC supply, mains voltage supply and DC-Bus link, you must prepare the connecting cables with wire end ferrules.

You can prepare cables with cross-section 2.5 mm² (up to to 6 mm²) with a uniform length of 170 mm, if the modules are lined up close together.

Use wire end ferrules with plastic collars, for example 2.5 mm² x 17 mm.

8.3.3.4 Cable cross sections and requirements

The tables below describe the recommended interface cross sections and cable requirements related to AKD2G in accordance with IEC 60204. For multi-axes systems, observe the specific operating conditions for your system.

Power Cables		Cross Section		Remarks
		EU	US	
Mains supply	1x3 A:	1.5 mm ²	14 awg	600 V rated ,minimum 75°C
	2x3 A:	1.5 mm ²	14 awg	
	1x6 A:	1.5 mm ²	14 awg	
	2x6 A:	2.5 mm ²	14 awg	
	1x12 A:	2.5 mm ²	14 awg	
24 V supply	max.	2.5 mm ²	14 awg	single core
DC bus link, Regen resistor	3/6 A:	1.5 mm ²	14 awg	1000 V rated, min. 75°C, shielded for lengths >0.20 m
	12 A:	2.5 mm ²	14 awg	
I/O cables				
Analog I/Os	min.	0.25 mm ²	24 awg	shielded twisted pairs
Digital I/Os		0.5 mm ²	20 awg	single core

Motor Power Cable (power) & Motor Combination Cable (power & brake)

Cross Section [mm]		Current Carrying Capacity	Remarks
Cable	Combi Cable		
(4x1)	(4x1.0+(2x0.75))	0A < I _{0rms} ≤ 10.1A	1000 V Rated, 80°C Current carrying capacity acc. to IEC 60204-1:2006 Table 6, Column B2 The brackets (...) show the shielding.
(4x1.5)	(4x1.5+(2x0.75))	10.1A < I _{0rms} ≤ 13.1A	
(4x2.5)	(4x2.5+(2x1.0))	13.1A < I _{0rms} ≤ 17.4A	
(4x4)	(4x4.0+(2x1.0))	17.4A < I _{0rms} ≤ 23A	
(4x6)	(4x6.0+(2x1.0))	23A < I _{0rms} ≤ 30A	

Motor Feedback Cable

Type	Cross Section [mm]	Remarks
Resolver	(4x2x0.25)	300 V rated, 80°C Shielded twisted pairs The brackets (...) show the shielding.
EnDat 2.1, BiSS B	(6x2x0.25)	
HIPERFACE	(5x2x0.25)	
EnDat 2.2, BiSS C	(5x2x0.25)	
SFD	(3x2x0.25)	
Comcoder	(8x2x0.25)	

Motor Hybrid Cable

Type	Cross Section [mm]	Current Carrying Capacity	Remarks
SFD3/DSL	(4x1.0+(2x0.34)+(2x0.75))	0A < I _{0rms} ≤ 10.1A	1000 V rated, 80°C Current carrying capacity acc. to IEC 60204-1:2006 Table 6, Column B2
SFD3/DSL	(4x1.5+(2x0.34)+(2x0.75))	10.1A < I _{0rms} ≤ 13.1A	
SFD3/DSL	(4x2.5+(2x0.34)+(2x1.0))	13.1A < I _{0rms} ≤ 17.4A	
SFD3/DSL	(4x4.0+(2x0.34)+(2x1.0))	17.4A < I _{0rms} ≤ 23A	
SFD3/DSL	(4x6.0+(2x0.34)+(2x1.0))	23A < I _{0rms} ≤ 30A	
Endat 2.2	(4x1.5+(2x0.75)+(2x2x0.14+2x0.25))	10.1A < I _{0rms} ≤ 13.1A	4 power lines & 2 brake lines & 2 SFD3/DSL signal lines or 6 EnDat 2.2 signal lines
Endat 2.2	(4x4.0+(2x1.0)+(2x2x0.14+2x0.25))	17.4A < I _{0rms} ≤ 23A	

8.3.4 Protective Earth connection

Protective Earth connection of the system components is a safety measure per IEC 60204. Ensure the proper grounding of all components with the PE rail in the control cabinet as reference potential. Connect each ground individually with the intended grounding cable (neutral point connection).

The leakage current from AKD2G against PE is more than 3.5 mA. In accordance with EN 61800-5-1, the PE connection must therefore either be double implemented or a connection cable with >10mm² cross-section used.

In order to keep the impedance as low as possible, we recommend a copper earthing strap for the PE connection on the PE block.

NOTE

Wire the PE connections immediately after installing the devices as the first electrical connection. Now you insert all the other lines and connectors. For disassembly, release the PE connections as the last connection.

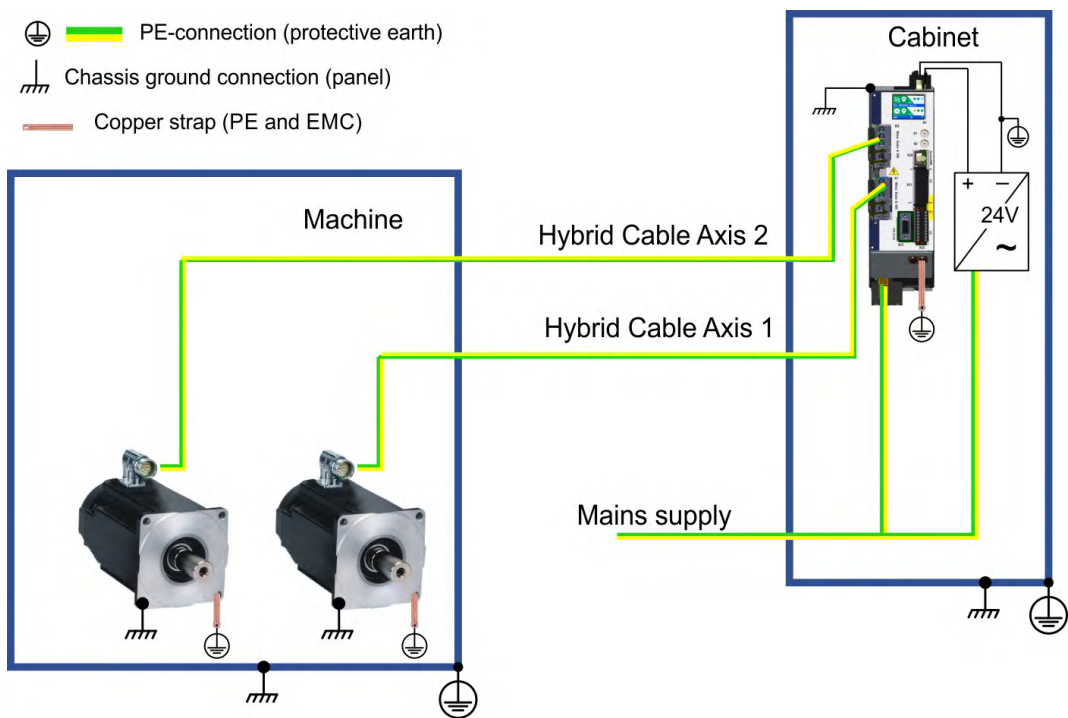

NOTE

For the use of residual current protective devices (RCD), refer to (→ # 20).

8.4 EMI Noise Reduction



CAUTION Electromagnetic Fields!

Electromagnetic radiation may, by acting on electrically conductive materials, lead to potential hazardous danger (warming, failure of implants).

- Work on the electrical installation may only be performed by trained and qualified personnel, in compliance with the regulations for safety at work, and only with switched off mains supply, and secured against restart.
- Grounding, equipotential bonding and radiation-reducing shields may not be removed.

8.4.1 Recommendations for EMI noise reduction

The following guidelines will help you to reduce problems with electrical noise in your application.

- **Ensure good connections between the cabinet components.** Connect the back panel and cabinet door to the cabinet body using several conductive braids. Never rely on hinges or mounting bolts for ground connections.
- **Ensure good ground connection.** Connect from cabinet to proper earth ground. Ground leads should be the same gauge as the leads to main power, but must cover the regional legal requirements, example (→ # 54).
- **Use Kollmorgen cables.** Route power and control cables separately, Kollmorgen recommends a distance of at least 200 mm to improve interference immunity.
- **Ground the shielding at both ends.** Ground all shielding with large areas (low impedance), with metalized connector housings or shield connection clamps wherever possible. For cables entering a cabinet, connect shields on all 360° of the cable. Never connect a simple “pigtail.” For more information on shielding concepts, (→ # 56).
- **With separate mains filter, maintain separation of leads entering and exiting the mains filter (line power filter).** Locate the filter as close as possible to the point where the incoming power enters the cabinet. If it is necessary for input power and motor leads to cross, cross them at 90°.
- **Observe cable length limits.** Maximum distance for unshielded I/O lines is 3 m inside the cabinet. If the I/O cable leaves the cabinet, it must be EMC shielded.
- **Feedback lines and Hybrid Cables may not be extended, since the shielding would be interrupted and the signal processing may be disturbed.** Install all feedback cables with an adequate cross-section, per IEC 60204 (→ # 52) and use the requested cable material to reach maximum cable length.
- **Splice cables properly.** If you need to divide cables, use connectors with metal backshells. Ensure that both shells connect along the full 360° of the shields.
- **Use differential inputs for analog signals.** Noise susceptibility in analog signals is greatly reduced by using differential inputs. Use twisted-pair, shielded signal lines, connecting shields on both ends.
- **Cables between drives and filters or external regen resistors must be shielded.** Install all power cables with an adequate cross-section per IEC 60204 (→ # 52) and use the requested cable material to reach maximum cable length.

8.4.2 Shielding with external shielding busbar

For best practice use of shielded cables Kollmorgen recommends a star point shield connection, for example, with a shielding busbar.

8.4.2.1 Shielding Concept

Example with AKD2G-Sxx--6Vxx, EMC filter and external regen resistor.

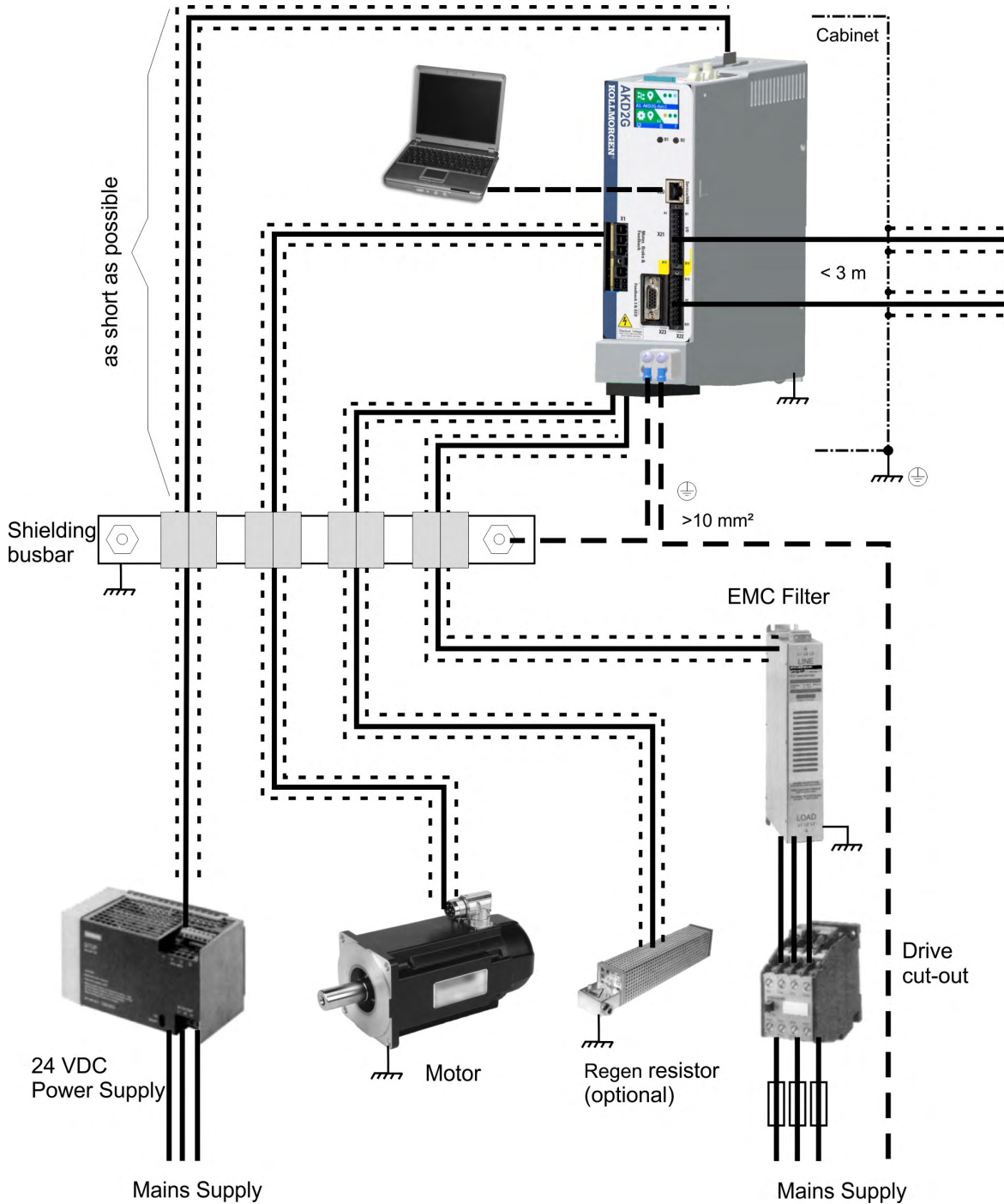

8.4.2.2 Shielding Busbar



The power cable shields (line in, motor cable, external regen resistor) can be routed to an additional busbar via shield clamps.

Kollmorgen recommends using Weidmüller KLBÜ shield clamps.

A possible scenario for setting up a busbar for the above shield clamps is described below.

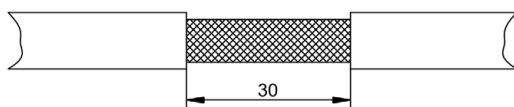
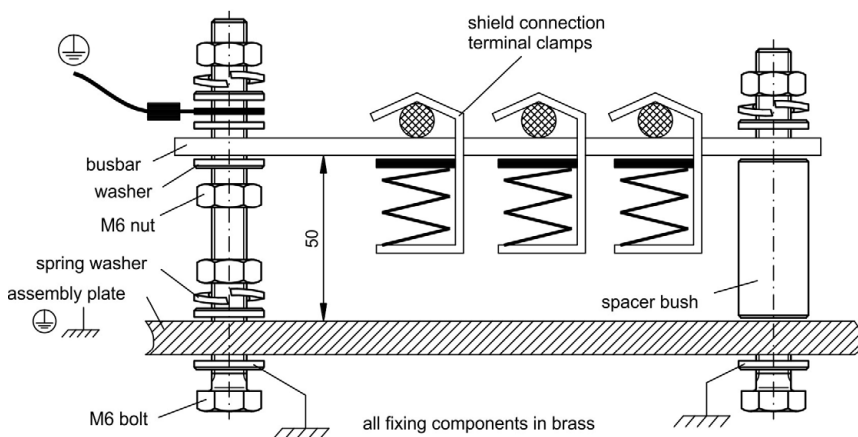
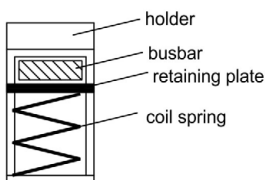
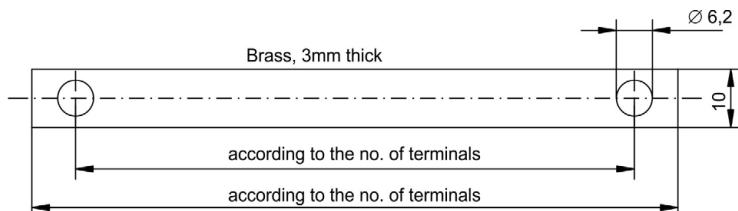

1. Cut a busbar of the required length from a brass rail (cross-section 10 x 3 mm) and drill holes in it as indicated. All shield clamps required must fit between the drill holes.

CAUTION

Risk of injury due to the spring force of the coil spring.
Use pliers.

2. Squeeze together the coil spring and the supporting plate and push the busbar through the opening in the holder.

3. Mount the busbar with the shield clamps fitted on the assembly plate. Use either metal spacer bushes or screws with nuts and accessories to maintain a spacing of 50 mm. Earth the busbar using a single conductor with a cross-section of at least 2.5 mm².

4. Strip the external cable sheath to a length of approx. 30 mm, taking care not to damage the braided shield. Push the shield clamp up and route the cable to it via the busbar.

NOTICE

Make sure there is good contact between the shield clamp and the braided shield.

8.4.3 Shielding connection to the drive

You can connect cable shielding directly to the drive by using grounding plates, shield connection clamps, and a motor connector with strain relief and grounding plate.

8.4.3.1 Shielding Concept

Example with AKD2G-Sxx--7Vxx, dual-axis.

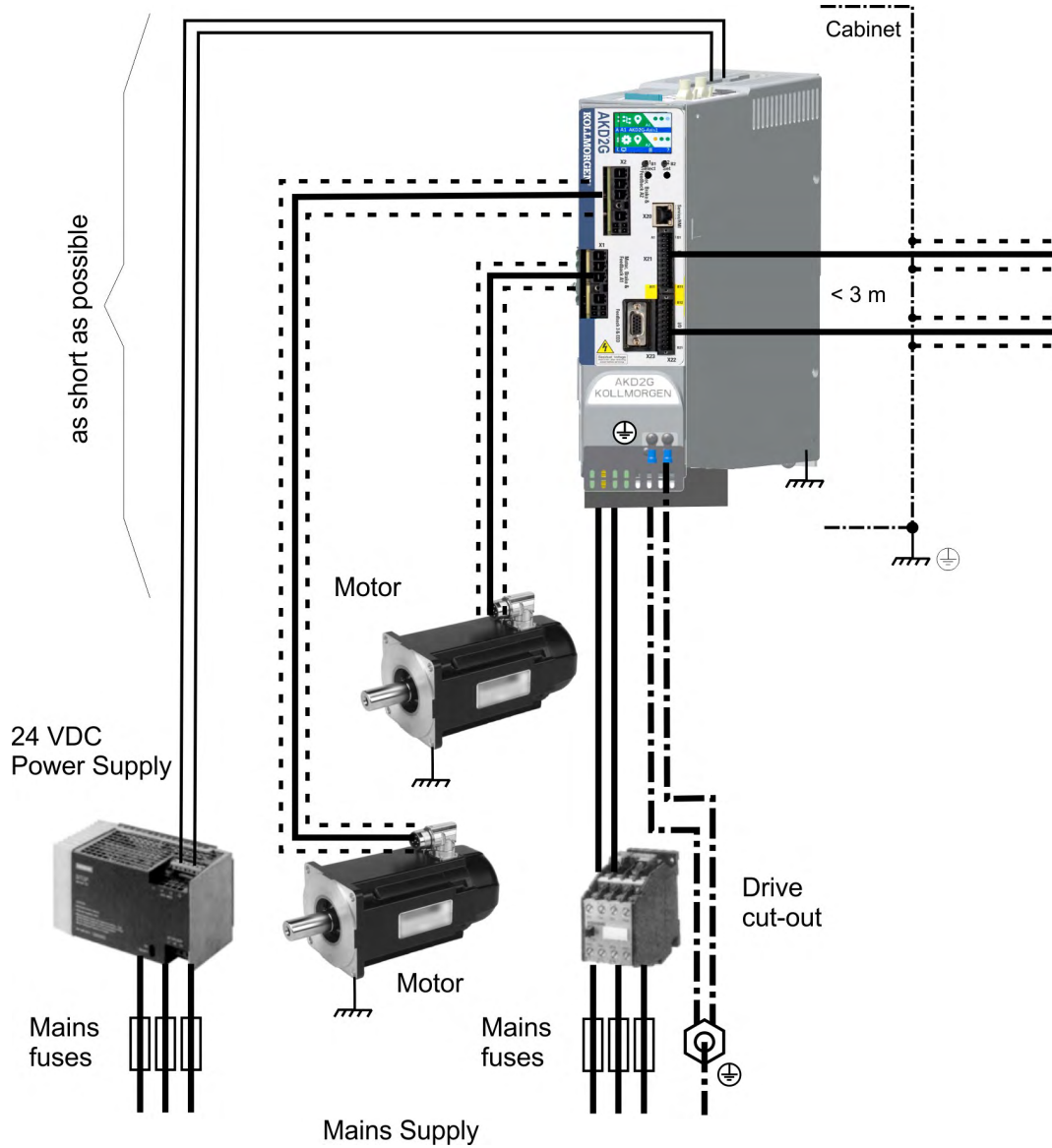

8.4.3.2 Grounding plates and shield connection clamps

A grounding plate is mounted to the drive.



Use shield connection clamps (see accessories manual). These hook into the grounding plate and ensure optimum contact between the shield and the grounding plate.

Kollmorgen recommends using Phoenix Contact SK14 shield clamps with cable clamp range of 6-13mm.

8.4.3.3 Motor connector X1/X2 with shielding connection

Alternative connection for the motor power connection by mating connector with shield plate and strain relief. Kollmorgen motor power and hybrid motor cables are configured with shield plate.

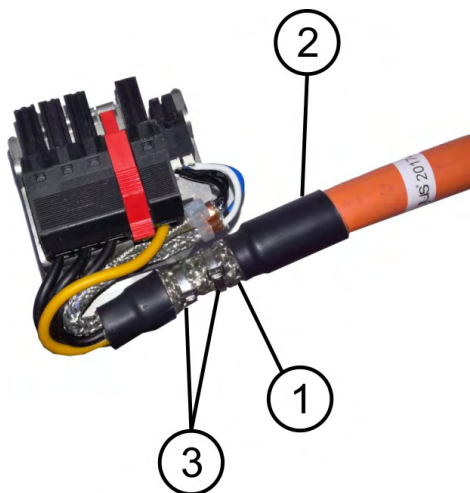

Strip the external cable sheath to a length of approx. 80 mm, taking care not to damage the braided shield. Push the braided shield (1) back over the cable and secure with a rubber sleeve (2) or shrink sleeve.

Shorten all the wires apart from the protective earth (PE) wire (green/yellow) by about 20 mm so that the PE wire is now the longest wire. Strip all wires and fit wire end ferrules.

Secure the braided shield of the cable with metal cable ties (3) and fasten the cable.

Wire the connector as shown in the connection diagram. Plug in the connector to the socket on the front of the AKD2G and secure it with the red clip.

8.5 Connection Overview

8.5.1 Connector Position AKD2G-Sxx-6VxxS

NOTE The graphics shows a single axis drive (supply voltage 110 V to 240 V)
Optional: F3 option for additional X23 (→ # 29).

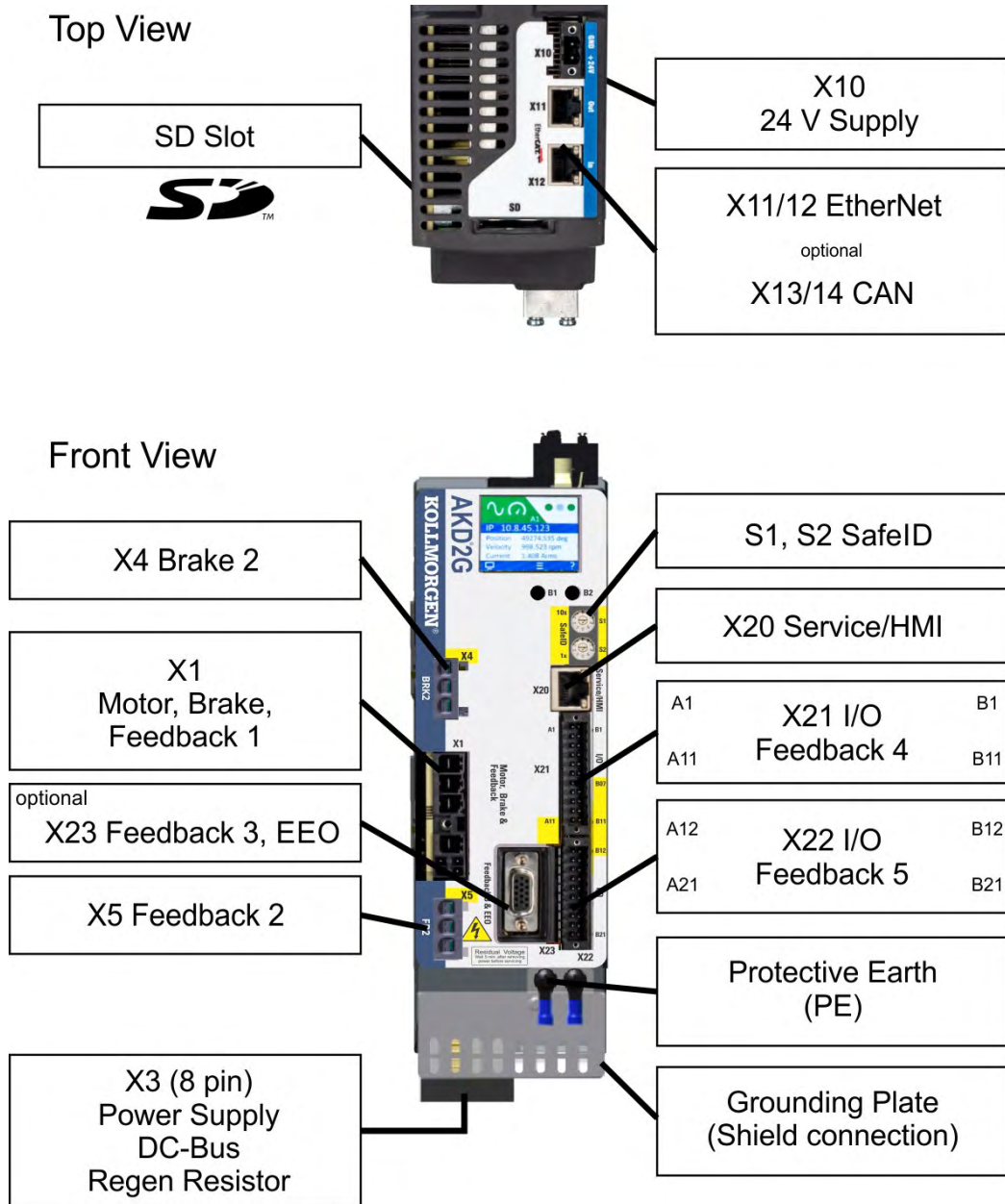

8.5.2 Connector Position AKD2G-Sxx-7VxxS

NOTE

The graphics shows a single axis drive (supply voltage 240 V to 480 V).
Optional: F3 option for additional X23 (→ # 29).

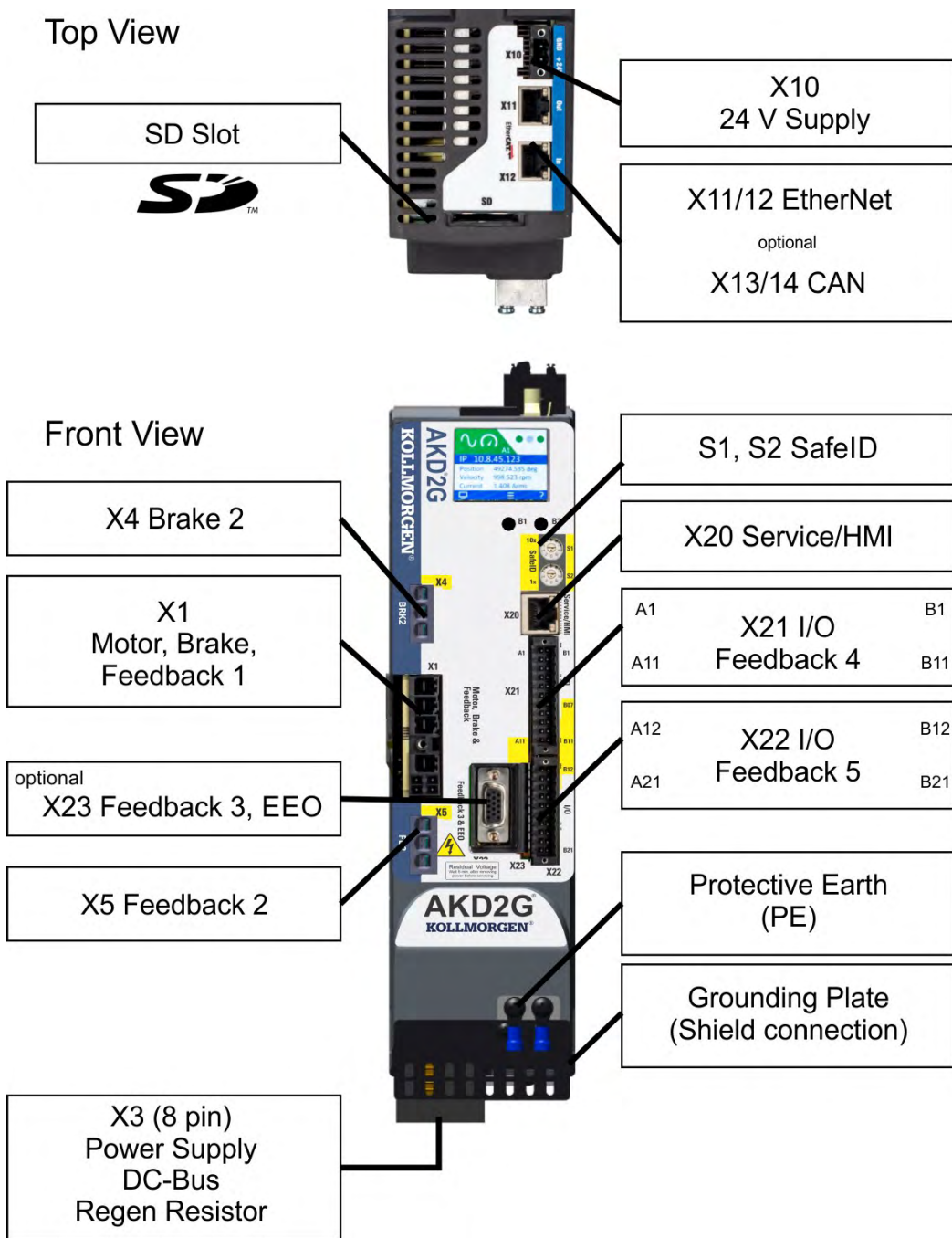

8.5.3 Connector Position AKD2G-Sxx-6VxxD

NOTE

The graphics shows a dual axis drive (supply voltage 110 V to 240 V).
Optional: F3 option for additional X23 (→ # 29).

Top View

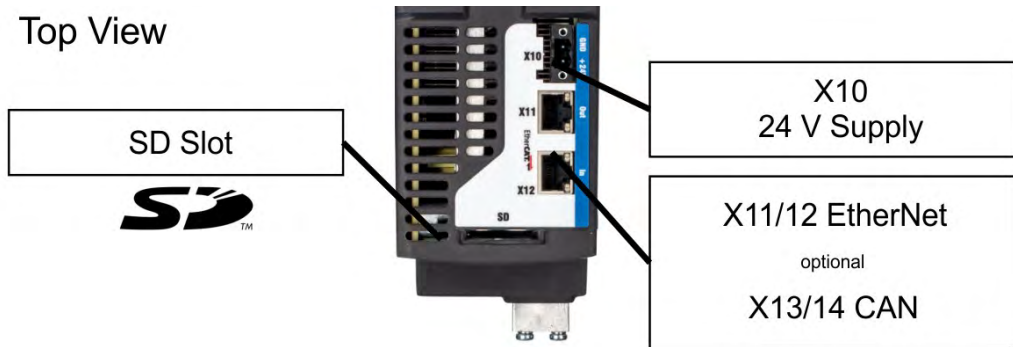

Front View

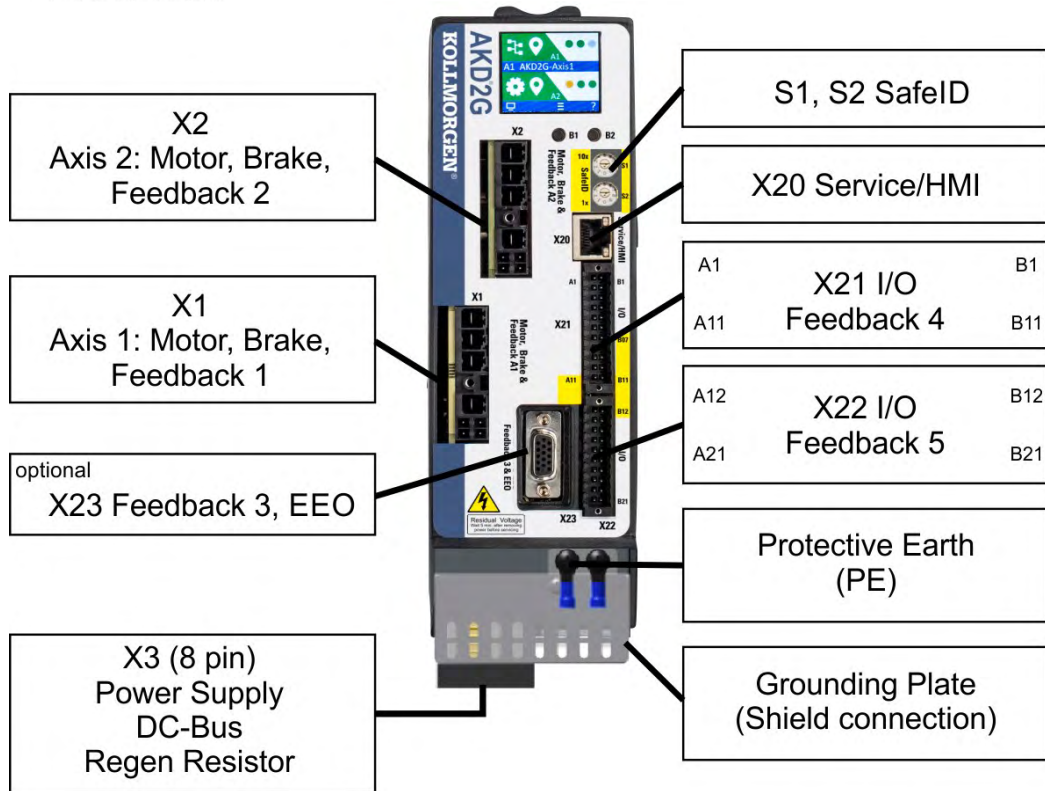

8.5.4 Connector Position AKD2G-Sxx-7VxxD

NOTE

The graphics shows a dual axis drive (supply voltage 240 V to 480 V).
Optional: F3 option for additional X23 (→ # 29).

Top View

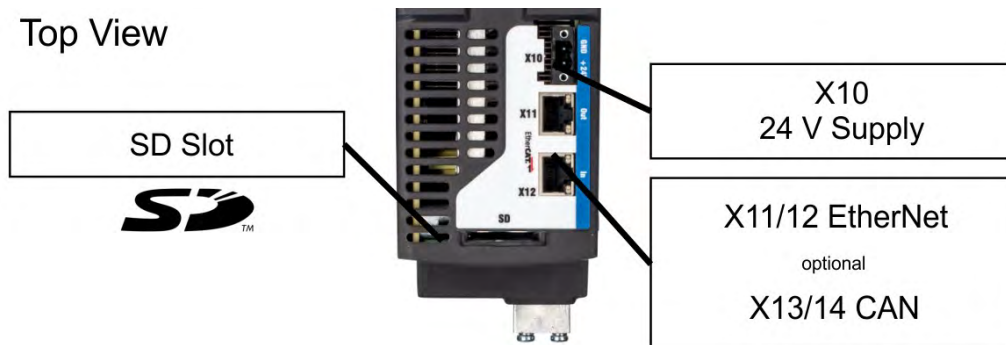

Front View

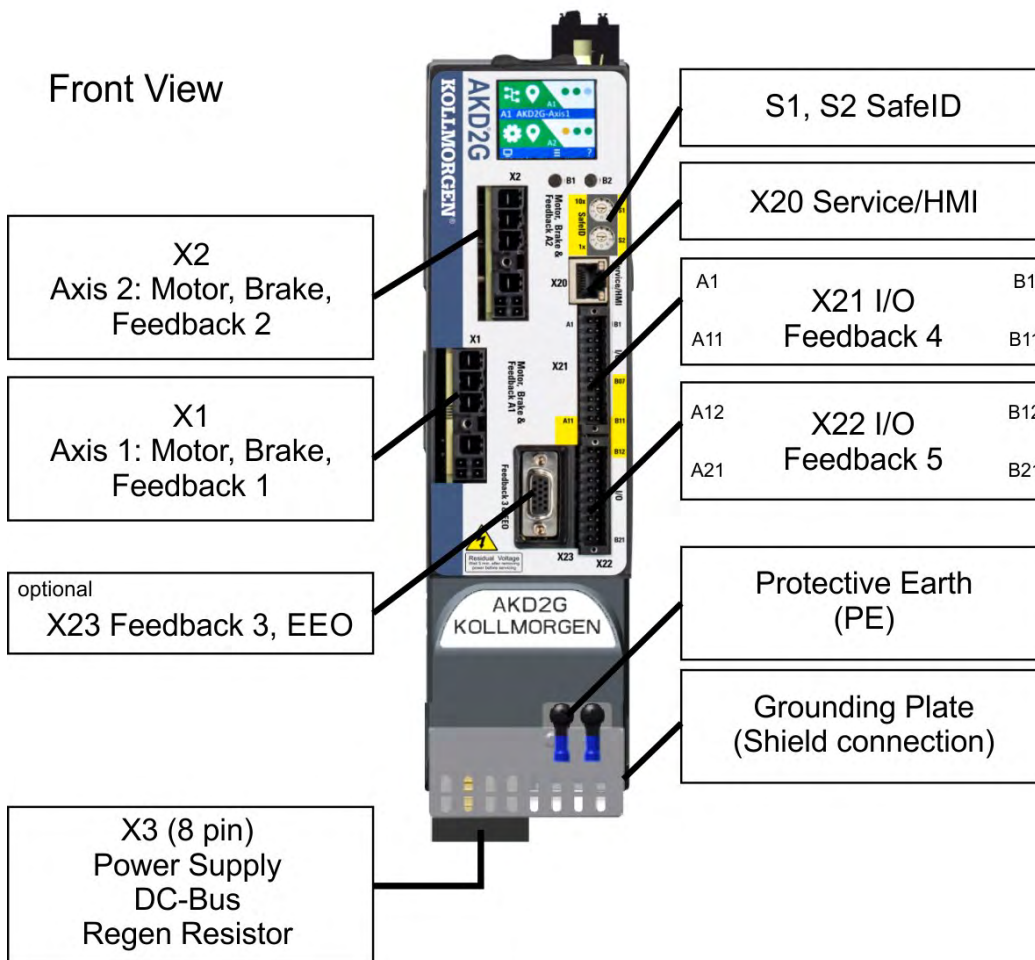

8.5.5 Wiring overview, single axis drive

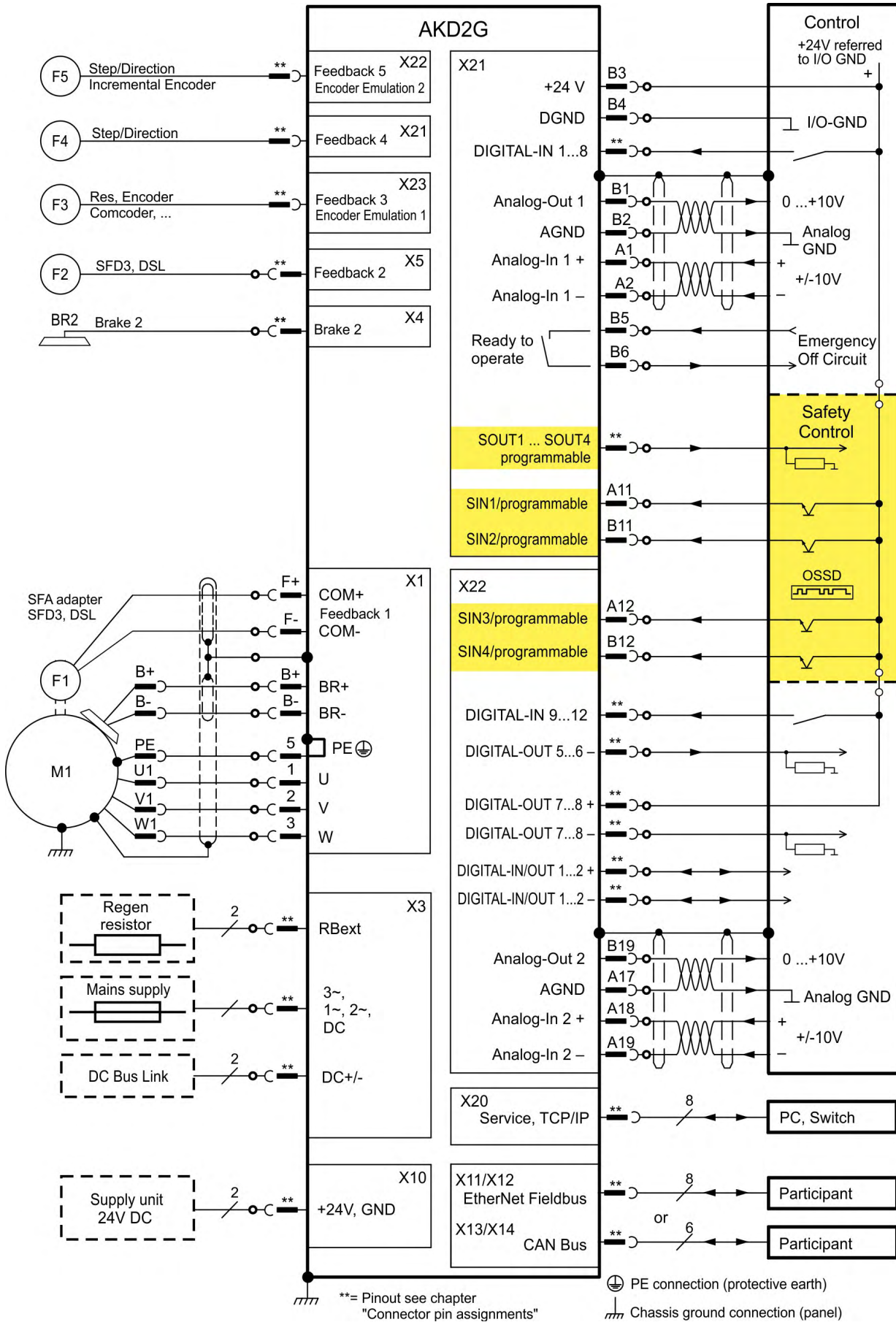

8.5.6 Wiring overview, dual axis drive

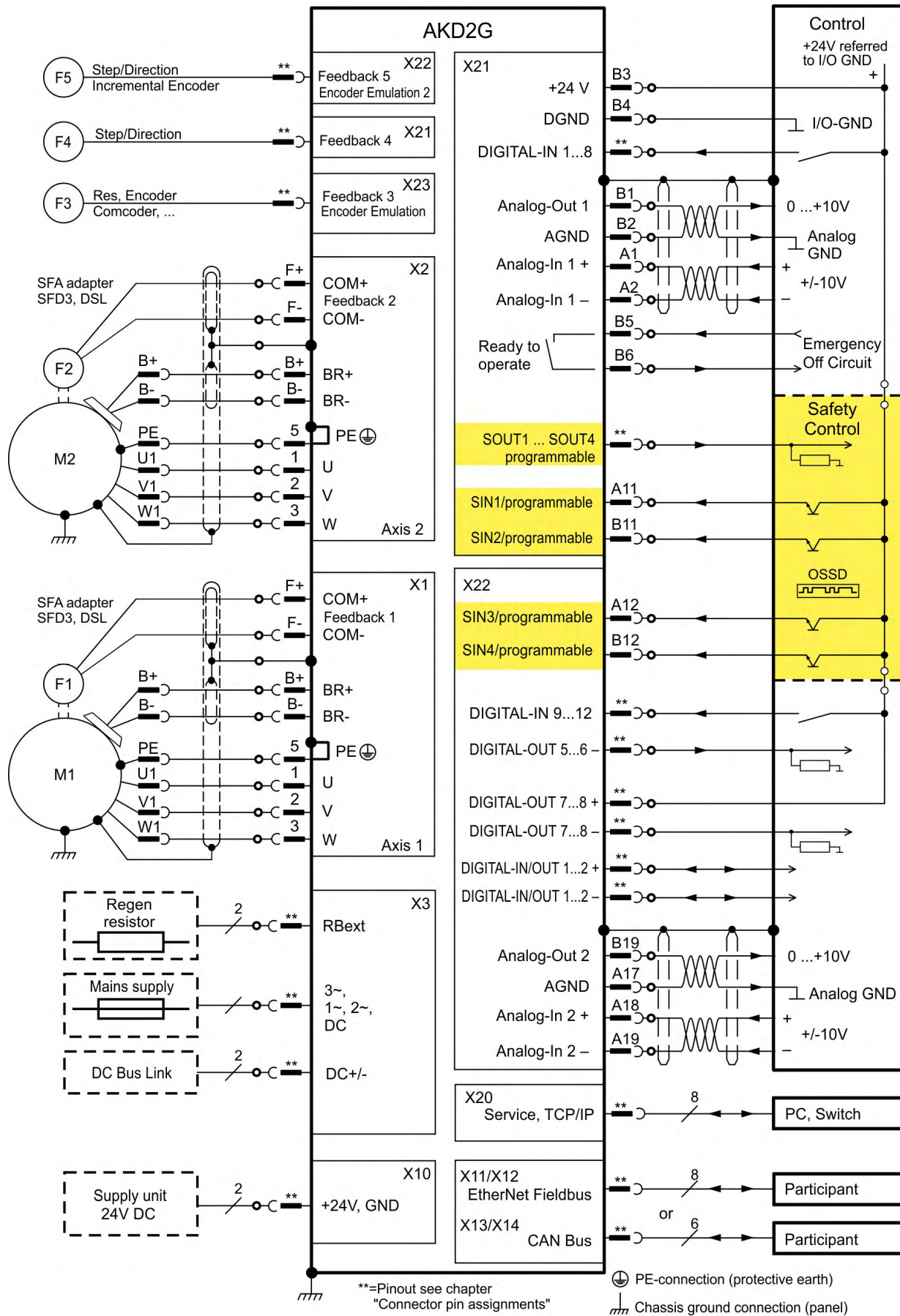

8.5.7 Connector pinout

Information to wiring, mating connectors and cables (→ # 51).

8.5.7.1 X1 and X2: Motor, Brake, Feedback 1

1 (U) ● 4 pin, pitch 7.62 mm plus 2x2 pin pitch 3.81 mm
 ● Spring clamps
 2 (V) ● Locking screw, tightening torque 0.5 Nm (4.4 inlbs)
 3 (W) ● Motor power, Motor brake (X1: axis 1, X2: axis 2)
 ● X1: Input for commutation feedback 1 (→ # 94)
 ● X2: Input for commutation feedback 2 (→ # 94)
 5 (PE) ● Wiring example:
 - DC Bus link (→ # 82)
 - Motor single cable connection (→ # 85)
 - Motor dual cable connection (→ # 88)

Pin	Label	Signal	Description
1	U	U	Motor phase U
2	V	V	Motor phase V
3	W	W	Motor phase W
retention latch, shield screw			
5	PE	PE	Protective earth
B+	B+	BR+	Motor holding brake +
B-	B-	BR-	Motor holding brake -
F+	F+	COM+	SFD3 + or HIPERFACE DSL +
F-	F-	COM-	SFD3 - or HIPERFACE DSL -

8.5.7.2 X3: Mains, regen resistor, DC-Bus

1 ● 8 pin, pitch 7.62 mm
 ● Screw terminals, tightening torque 0.5 to 0.6 Nm (4.4 to 5.3 inlbs)
 2 ● Locking screw, tightening torque 0.5 Nm (4.4 inlbs)
 3 ● Optional T version
 4 ● Mains supply, External regen resistor, DC Bus
 ● X3/5 to X3/6 must be shorted to use the built in regen resistor. Remove the jumper to connect an external regen resistor .
 5 ● Wiring example:
 - Power supply (→ # 73)
 - DC Bus link (→ # 82)
 - External regen resistor (→ # 84)

Pin	Label	Signal	Description
1	PE	PE	Protective earth
2	R	L1	3~ mains supply L1, 1~ supply L, DC supply +
3	S	L2	3~ mains supply L2
4	T	L3	3~ mains supply L3, 1~ supply N, DC supply -
5	Ri	RBint	internal regen resistor
6	RE	-RB	external regen resistor -
7	+DC	+DC (+RBext)	DC Bus link+ and/or external regen resistor +
8	-DC	-DC	DC Bus link -

8.5.7.3 X4: Second Brake

NOTE

Use with single axis drives and Safety Option 2 for safety functions, which require a second brake.

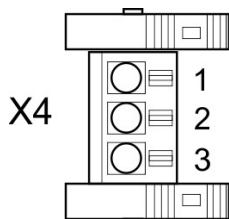

- 3 pin, pitch 3.81 mm
- Spring clamps
- Second motor brake
- Required for SIL3 brake control

Pin	Signal	Description
1	PE	Protective earth
2	BR2-	Second (external) brake -
3	BR2+	Second (external) brake +

8.5.7.4 X5: Feedback 2

NOTE

Use with single axis drives and Safety Option 2 for application, which require a second feedback.

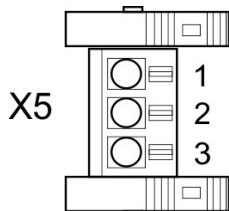

- 3 pin, pitch 3.81 mm
- Spring clamps
- Input for feedback 2 (→ # 94)

Pin	Signal	Description
1	PE	Protective earth
2	COM2-	Second SFD3 - or Second/Safe HIPERFACE DSL -
3	COM2+	Second SFD3 + or Second/Safe HIPERFACE DSL +

8.5.7.5 X10: 24 VDC

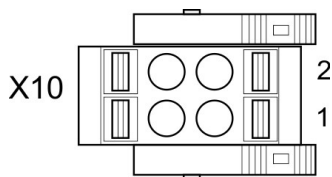

- 2 pin, pitch 5.08 mm
- Spring clamps
- T version
- 24 VDC supply voltage
- Wiring example: (→ # 81)

Pin	Signal	Description
1	+ 24 V	+24 VDC supply voltage, PELV
2	GND	Ground for 24 VDC supply voltage, PELV

8.5.7.6 X11, X12: EtherNet Fieldbus

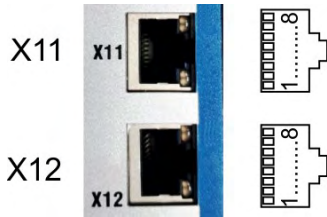

- RJ45 with built-in green/red dual-color LED
- EtherCAT, EtherNet/IP*, PROFINET*
- Interface Details: (→ # 104)

*available 2021

Pin	Signal	Description	Pin	Signal	Description
1	Tx+	Transmit +	5	Term.	Termination
2	Tx-	Transmit -	6	Rx-	Receive -
3	Rx+	Receive +	7	Term.	Termination
4	Term.	Termination	8	Term.	Termination

8.5.7.7 X13, X14: CAN bus (optional)

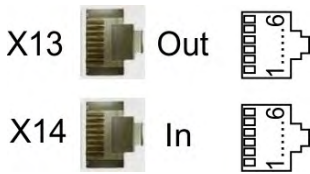

- RJ25
- X14 IN port, X13 OUT port
- Up to 1 Mbit operation
- Node ID to be set by WorkBench
- Interface Details: (→ # 107)

Pin	Signal	Description	Pin	Signal	Description
1	n.c.	not used	4	CAN_low	CAN bus low signal
2	Shield	Chassis	5	CAN_GND	CAN bus ground
3	CAN_high	CAN bus high signal	6	n.c.	not used

8.5.7.8 X20: Service



- RJ45 with built-in green and yellow LEDs
- 100/10 Mbit EtherNet TCP/IP, Modbus/TCP
- Supports auto-IP, DHCP and fixed IP addressing
- Supports point-to-point (i.e. Auto-IP) and connection by using network switches
- Supports automatic discovery in WorkBench if in the same sub-net.
- Interface Details: (→ # 110)

Pin	Signal	Description	Pin	Signal	Description
1	Tx+	Transmit +	5	Term.	Termination
2	Tx-	Transmit -	6	Rx-	Receive -
3	Rx+	Receive +	7	Term.	Termination
4	Term.	Termination	8	Term.	Termination

8.5.7.9 X21: I/O, Feedback 4

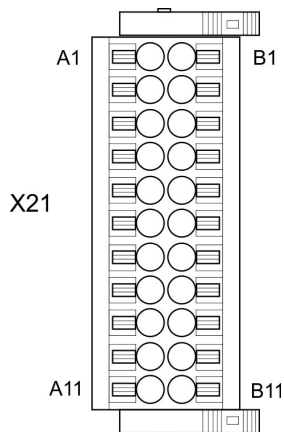

- 2 x 11 pins (left column A, right column B), pitch 3.5 mm
- Spring clamps
- Analog and digital I/O
- Input for feedback 4 (→ # 94)
- Wiring examples:
 - Analog input (→ # 114)
 - Analog output (→ # 115)
 - Digital input (→ # 116)
 - Digital Output (→ # 120)
 - Feedback (→ # 97)

Digital I/O connectivity

Pin	Signal	Description
A1	Analog-In (AIN) 1 +	Analog Input +/- 10 V
A2	Analog-In (AIN) 1 -	
A3*	Digital-In (DIN) 1	Fast, isolated, sink, type EN 61131-2 type 1
A4*	Digital-In (DIN) 2	Fast, isolated, sink, type EN 61131-2 type 1
A5	Digital-In (DIN) 3	Slow, isolated, sink, type EN 61131-2 type 1
A6	Digital-In (DIN) 4	Slow, isolated, sink, type EN 61131-2 type 1
A7	Digital-In (DIN) 5	Slow, isolated, sink, type EN 61131-2 type 1
A8	Digital-In (DIN) 6	Slow, isolated, sink, type EN 61131-2 type 1
A9	Digital-In (DIN) 7	Slow, isolated, sink, type EN 61131-2 type 1
A10	Digital-In (DIN) 8	Slow, isolated, sink, type EN 61131-2 type 1
A11	SIN1	Slow, isolated, sink, fail-safe, functional safety input 1
B1	Analog-Out (AOUT) 1	Analog Output, 0 to +10 V
B2	AGND	Ground for analog I/O
B3	+24 V	+24 VDC for digital I/O and STO
B4	DGND	Ground for digital I/O and STO
B5	Digital-Out (DOOUT) 9 +	Relay contact, normally open, 24 VDC, 1A
B6	Digital-Out (DOOUT) 9 -	Relay contact, normally open, 24 VDC, 1A
B7	SOUT1	Isolated, high-side, safety: 172 mA, safe output
B8	SOUT2	Isolated, high-side, safety: 172 mA, safe output
B9	SOUT3	Isolated, high-side, safety: 172 mA, safe output
B10	SOUT4	Isolated, high-side, safety: 172 mA, safe output
B11	SIN2	Slow, isolated, sink, fail-safe, functional safety input 2

*Feedback 4 connectivity, Step/Direction CW/CCW (input)

Pin	Signal	Description
A3	Step, CW	Fast, isolated, sink, type EN 61131-2 type 1
A4	Direction, CCW	Fast, isolated, sink, type EN 61131-2 type 1

8.5.7.10 X22: I/O, EEO2, Feedback 5

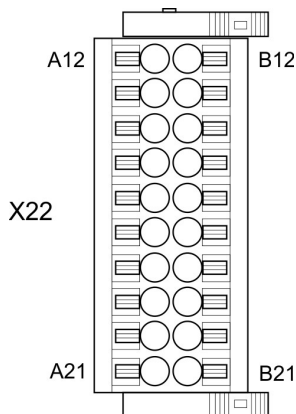

- 2 x 10 pins (left column A, right column B), pitch 3.5 mm
- Spring clamps
- Analog and digital I/O
- Input for feedback 5 (→ # 94)
- Output for incremental encoder emulation (EEO2)
- Wiring examples:
 - Analog input (→ # 114)
 - Analog output (→ # 115)
 - Digital input (→ # 116)
 - Digital output (→ # 120)
 - Feedback (→ # 98)
 - Encoder emulation (EEO2) (→ # 101)
 - Master-Slave (→ # 103)

Digital I/O connectivity

Pin	Signal	Description
A12	SIN3	Slow, isolated, sink, fail-safe, functional safety input 3
A13	Digital-In (DIN) 9	Slow, isolated, sink, type EN 61131-2 type 1
A14	Digital-In (DIN) 10	Slow, isolated, sink, type EN 61131-2 type 1
A15	Digital-In (DIN) 11	Slow, isolated, sink, type EN 61131-2 type 1
A16	Digital-In (DIN) 12	Slow, isolated, sink, type EN 61131-2 type 1
A17	AGND	Ground for analog I/O
A18	Analog-In (AIN) 2+	Analog Input, +/- 10 V
A19	Analog-In (AIN) 2-	
A20*	Digital-In/Out (DIO) 1 +	RS485 input or output
A21*	Digital-In/Out (DIO) 1 -	RS485 input or output
B12	SIN4	Slow, isolated, sink, fail-safe, functional safety input 4
B13	Digital-Out (DOU) 5	Isolated, high-side, 100 mA
B14	Digital-Out (DOU) 6	Isolated, high-side, 100 mA
B15	Digital-Out (DOU) 7 +	Fast, isolated, sink or source, 100 mA
B16	Digital-Out (DOU) 7 -	
B17	Digital-Out (DOU) 8 +	Fast, isolated, sink or source, 100 mA
B18	Digital-Out (DOU) 8 -	
B19	Analog-Out (AOUT) 2	Analog Output, 0 to +10 V
B20*	Digital-In/Out (DIO) 2 +	RS485 input or output
B21*	Digital-In/Out (DIO) 2 -	RS485 input or output

*Feedback 5 (input)

*EEO2 (output)

Pin	Increm. Encoder	Step/Dir	CW/CCW	BiSS B/C EnDAT 2.2	SSI	Pin	Increm. Encoder
A20	Track A +	Step +	CW +	CLK+	CLK+	A20	A+
A21	Track A -	Step -	CW -	CLK-	CLK-	A21	A -
B20	Track B +	Dir +	CCW +	DAT+	DAT+	B20	B+
B21	Track B -	Dir -	CCW -	DAT-	DAT-	B21	B -

8.5.7.11 X23: I/O, EEO1, Feedback 3

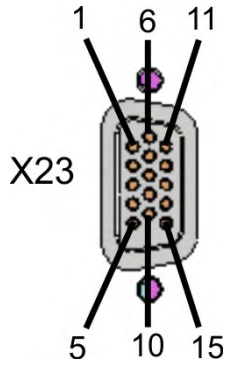

- Sub-D high density 15 pin, female
- Locking screws, tightening torque 0.4 Nm (3.5 inlbs)
- Input for feedback 3 (→ # 94)
- Output for incremental encoder emulation (EEO1)
- Additional Digital-In/Out
- Wiring examples:
 - Feedback (→ # 99)
 - Encoder emulation (EEO1) (→ # 102)
 - Master-Slave (→ # 103)
 - Digital input (→ # 116)
 - Digital output (→ # 120)

Feedback 3 connectivity (input)

X23 Pin	SFD	Resol- ver	BiSS		EnDat		HIPER- FACE	Sin / Cos	Sin / Cos +Hall	Incr. Enc.	Incr. Enc. +Hall	Hall	SSI	Step/ Dir	CW/ CCW
			B	C	2.1	2.2									
1	-	-	-	-	-	-	-	-	Hall U	-	Hall U	Hall U	-	-	-
2	-	-	CL+	CL+	CL+	CL+	-	-	Hall V	-	Hall V	Hall V	CL+	-	-
3	-	-	CL-	CL-	CL-	CL-	-	-	Hall W	-	Hall W	Hall W	CL-	-	-
4	S+	-	S+	S+	S+	S+	S+	S+	S+	S+	S+	-	-	-	-
5	S-	-	S-	S-	S-	S-	S-	S-	S-	S-	S-	-	-	-	-
6	COM+	R1 Ref+	D+	D+	D+	D+	D+	Z+	Z+	Z+	Z+	-	D+	-	-
7	COM-	R2 Ref-	D-	D-	D-	D-	D-	Z-	Z-	Z-	Z-	-	D-	-	-
8	-	Th+	Th+	-	Th+	-	Th+	Th+	Th+	Th+	Th+	Th+	-	Th+	Th+
9	-	Th-	Th-	-	Th-	-	Th-	Th-	Th-	Th-	Th-	Th-	-	Th-	Th-
10	+5 V	-	+5 V	+5 V	+5 V	+5 V	8 to 9 V	+5 V	+5 V	+5 V	+5 V	+5 V	+5 V	+5 V	+5 V
11	0 V	-	0 V	0 V	0 V	0 V	0 V	0 V	0 V	0 V	0 V	0 V	0 V	0 V	0 V
12	-	S1 SIN+	A+	-	A+	-	SIN+	A+	SIN+	A+	A+	-	-	Step+	CW+
13	-	S3 SIN-	A-	-	A-	-	SIN-	A-	SIN-	A-	A-	-	-	Step-	CW-
14	-	S2 COS+	B+	-	B+	-	COS+	B+	COS+	B+	B+	-	-	Dir+	CCW+
15	-	S4 COS-	B-	-	B-	-	COS-	B-	COS-	B-	B-	-	-	Dir-	CCW-

CL = CLOCK, D = DATA, S = SENSE, Th = Thermal control, Z = Zero

EEO1 connectivity (output)

Pin	Incremental Encoder
6	Zero+
7	Zero-
11	0 V
12	A +
13	A-
14	B+
15	B-

Digital I/O connectivity

Pin	Digital I/O
2	Digital-In/Out 6 +
3	Digital-In/Out 6 -
6	Digital-In/Out 5 +
7	Digital-In/Out 5 -
10	+5 V
11	0 V
12	Digital-In/Out 3 +
13	Digital-In/Out 3 -
14	Digital-In/Out 4 +
15	Digital-In/Out 4 -

8.5.7.12 X41: SFA Feedback converter, EEO3/EEO4 (accessory)

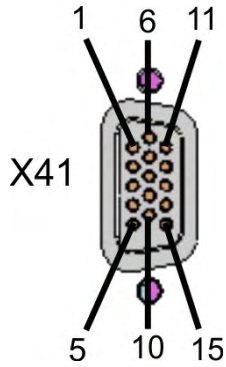

- Sub-D high density 15 pin, female
- Locking screws, tightening torque 0.4 Nm (3.5 inlbs)
- 1 m cable, 3 flying leads with ferrules for connection to X1, X2, X5
- Input for electronic gearing
- When connected to X1: Input for feedback 1 (→ # 94)
- When connected to X2: Input for feedback 2 (→ # 94)
- When connected to X5: Input for feedback 2 (→ # 94)
- Output for incremental encoder emulation (EEO3 / EEO4) (→ # 102)
- SFA Adapter converts conventional feedback signals to 2 wire feedback format
- Wiring examples:
 - Feedback and Encoder emulation (→ # 100)
 - Master-Slave (→ # 103)

Feedback 1/2 connectivity (input)

X41 Pin	SFD	Resol- ver	BiSS B	EnDat 2.1 2.2		HIPER- FACE	Sin / Cos	Si n / Cos +Hall	Incr. Enc.	Incr. Enc. +Hall	Hall	Step/ Dir	CW/ CCW
1	-	-	-	-	-	-	-	Hall U	-	Hall U	Hall U	-	-
2	-	-	CL+	CL+	CL+	-	-	Hall V	-	Hall V	Hall V	-	-
3	-	-	CL-	CL-	CL-	-	-	Hall W	-	Hall W	Hall W	-	-
4	S+	-	S+	S+	S+	S+	S+	S+	S+	S+	-	-	-
5	S-	-	S-	S-	S-	S-	S-	S-	S-	S-	-	-	-
6	COM+	R1 Ref+	D+	D+	D+	D+	Z+	Z+	Z+	Z+	-	-	-
7	COM-	R2 Ref-	D-	D-	D-	D-	Z-	Z-	Z-	Z-	-	-	-
8	-	Th+	Th+	Th+	-	Th+	Th+	Th+	Th+	Th+	Th+	Th+	Th+
9	-	Th-	Th-	Th-	-	Th-	Th-	Th-	Th-	Th-	Th-	Th-	Th-
10	+5 V	-	+5 V	+5 V	+5 V	8 to 9 V	+5 V	+5 V	+5 V	+5 V	+5 V	+5 V	+5 V
11	0 V	-	0 V	0 V	0 V	0 V	0 V	0 V	0 V	0 V	0 V	0 V	0 V
12	-	S1 SIN+	A+	A+	-	SIN+	A+	SIN+	A+	A+	-	Step+	CW+
13	-	S3 SIN-	A-	A-	-	SIN-	A-	SIN-	A-	A-	-	Step-	CW-
14	-	S2 COS+	B+	B+	-	COS+	B+	COS+	B+	B+	-	Dir+	CCW+
15	-	S4 COS-	B-	B-	-	COS-	B-	COS-	B-	B-	-	Dir-	CCW-

CL = CLOCK, D = DATA, S = SENSE, Th = Thermal control, Z = Zero

EEO3 / EEO4 connectivity (output)

X41 Pin	Incremental Encoder
6	Zero+
7	Zero-
11	0 V
12	A +
13	A-
14	B+
15	B-

8.6 Power and Logic Voltage Supply (X3/X10)

8.6.1 Mains power supply connector X3

Drives in the AKD2G series can be supplied as follows:

AKD2G-Sxx-6V

- 1, 2 or 3 phase industrial AC supply networks (TN-S or TT, see [KDN](#)):
120 V or 240 VAC nominal.
- DC supply networks: 17 VDC to 370 VDC.

AKD2G-Sxx-7V

- 3 phase industrial AC supply networks (TN-S or TT, see [KDN](#)):
240 V, 400 V or 480 VAC nominal.
- DC supply networks: 34 VDC to 740 VDC.

For connection to corner grounded delta supply networks contact Kollmorgen customer support.

Periodic overvoltages between phases (L1, L2, L3) and the PE/housing of the drive must not exceed 1000 V peak. In accordance with IEC 61800, voltage spikes ($< 50 \mu\text{s}$) between phases must not exceed 1000 V. Voltage spikes ($< 50 \mu\text{s}$) between a phase and the PE/housing must not exceed 2000 V.

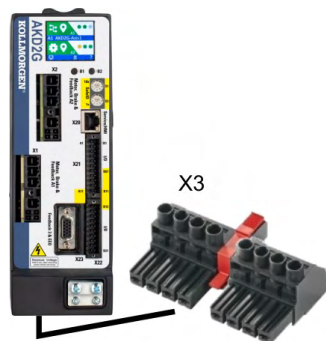

- 8 pin, pitch 7.62 mm
- optional T version
- Wiring example:
 - 1 phase AC supply (→ # 74)
 - 2 phase AC supply (→ # 74)
 - 3 phase AC supply (→ # 75)
 - DC supply (→ # 76)
- AKD2G-Sxx-6V requires external EMC filter for use in industrial environment, product category C.
- Mating connector data (→ # 51)
- Fusing with different system structures (→ # 77) ff

Pin	Label	Signal	1~ Supply	2~Supply	3~ Supply	DC Supply
1	PE	PE	Protective earth	Protective earth	Protective earth	Protective earth
2	R	L1	Phase L1	Phase L1	Phase L1	+ DC
3	S	L2	n.c.	n.c.	Phase L2	n.c.
4	T	L3	Neutral N	Phase L2	Phase L3	- DC

For DC supply: observe notes (→ # 76).

8.6.1.1 Wiring examples mains power supply

One phase AC mains (AKD2G-Sxx-6V)

- Directly to one phase supply network with neutral line.
- Activate single phase supply (VBUS.THREEPHASE = 0).
- Set VBUS.ACNO MINAL to desired nominal AC line voltage for lines other than nominal rated VAC.
- For complete information refer to WorkBench online help, AKD2G-S User Manual, section Power Setting.
- AC line filtering to be provided by the user. Use filter type FN2090, refer to the *Accessories Manual* for more information. Use shielded cable between filter and drive.

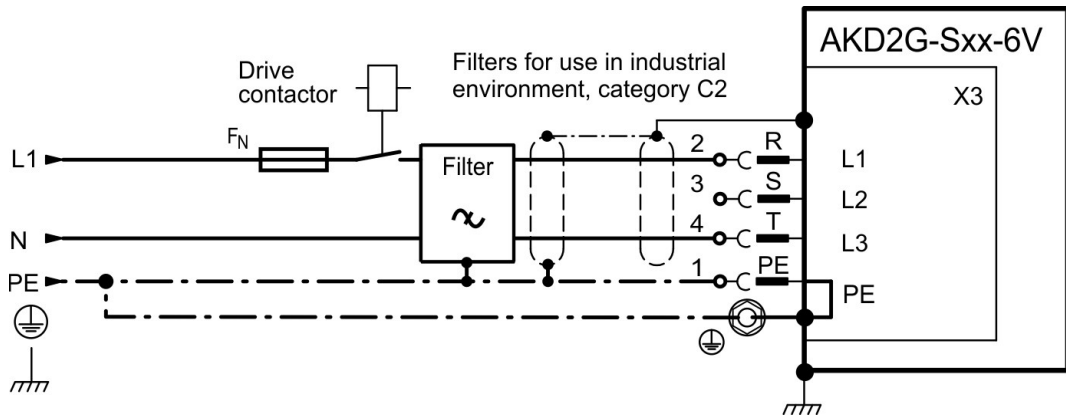

Two phases AC mains (AKD2G-Sxx-6V)

- Directly to two-phase supply network without neutral line.
- Activate single phase supply (VBUS.THREEPHASE = 0).
- Set VBUS.ACNO MINAL to desired nominal AC line voltage for lines other than nominal rated VAC.
- For complete information refer to WorkBench online help, AKD2G-S User Manual, section Power Setting.
- AC line filtering to be provided by the user. Use filter type FN2090, refer to the *Accessories Manual* for more information. Use shielded cable between filter and drive.

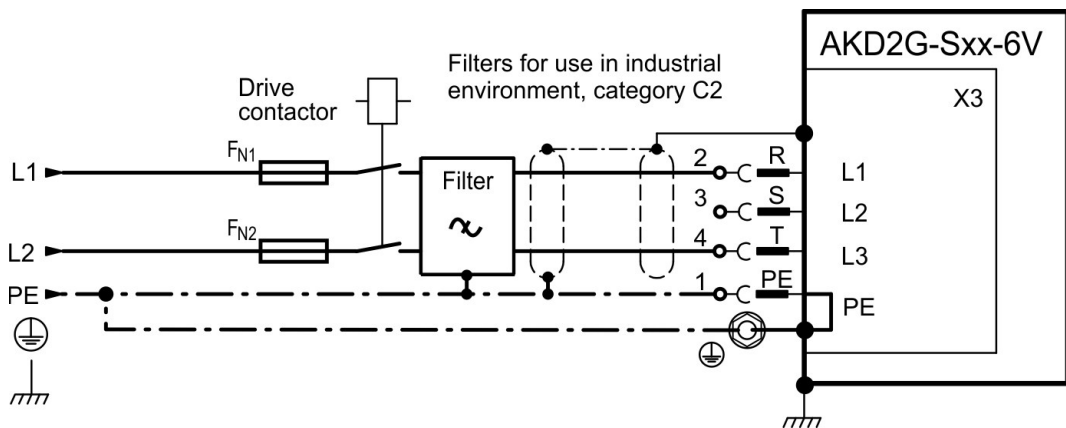

Three phases AC mains (all AKD2G-Sxx-)

- Directly to 3-phase supply network.
- Activate 3-phase supply (VBUS.THREEPHASE = 1).
- Set VBUS.ACNO MINAL to desired nominal AC line voltage for lines other than nominal rated VAC.
- For complete information refer to WorkBench online help, AKD2G-S User Manual, section Power Setting.
- AC line filtering to be provided by the user. Refer to the *Accessories Manual* for more filter description. Use shielded cable between filter and drive.
 - AKD2G-Sxx-6V:
 - Motor cable < 10 m: use filter FN 3288 in industrial environment, category C2.
 - Motor cable ≥ 10 m: use filter FN 3288 in industrial environment, category C3.
 - AKD2G-Sxx-7V:
 - Motor cable < 10 m: no filter, in industrial environment, category C3.
 - Motor cable < 10 m: use filter FN 3288 in industrial environment, category C2.
 - Motor cable ≥ 10 m: use filter FN 3288 in industrial environment, category C2.

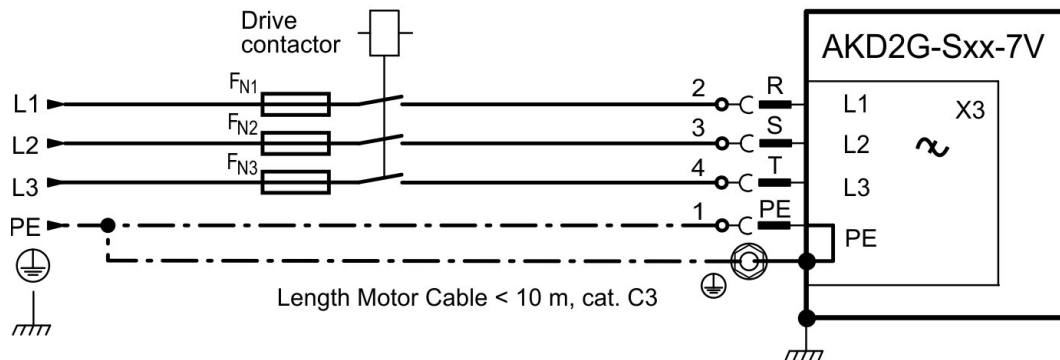
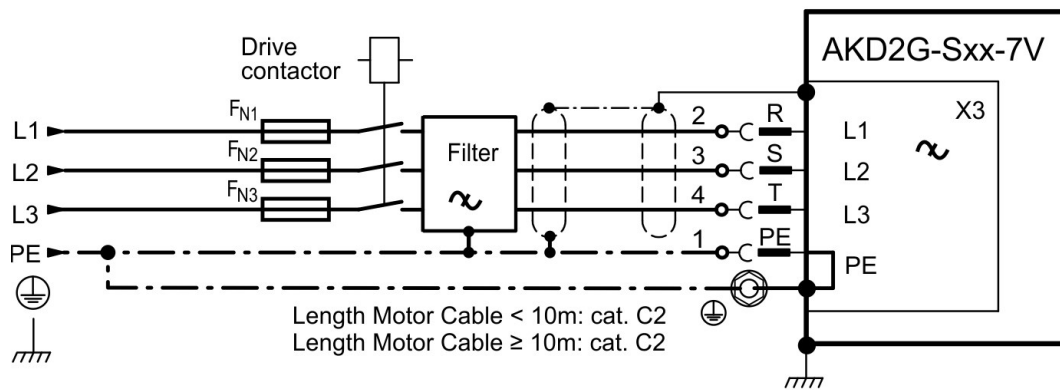
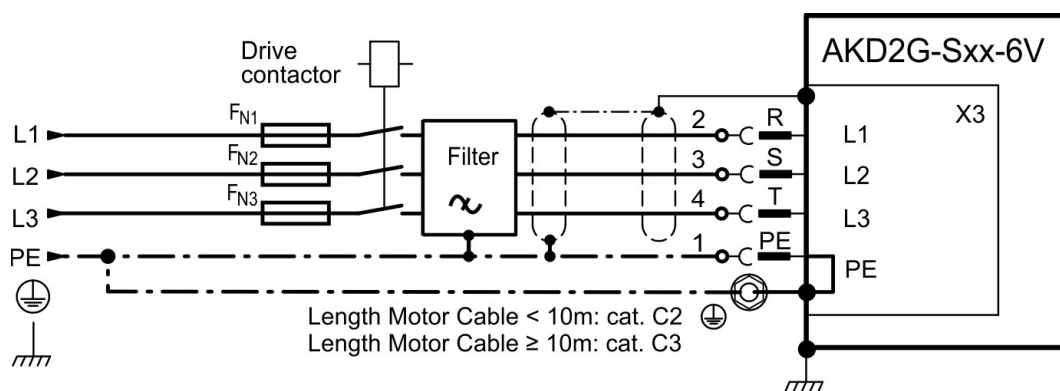

DC Supply (all AKD2G-Sxx-)

- Activate DC supply (VBUS.DCOPERATION = 1) and set VBUS.DCNOMINAL.
- Any DC supply filtering for AKD2G-Sxx-6V to be provided by the user.

DC Supply to mains lines R/T (L1/L3)

DC power source is connected to the drive AC line inputs. This wiring provides soft start of the energy storage capacitors inside the drive and the AC rectifier diodes prevents motor regeneration energy from returning to the dc power source. That is, by powering the drive from the AC line input connections, the drive's energy absorption and energy dissipation mechanisms can work normally.

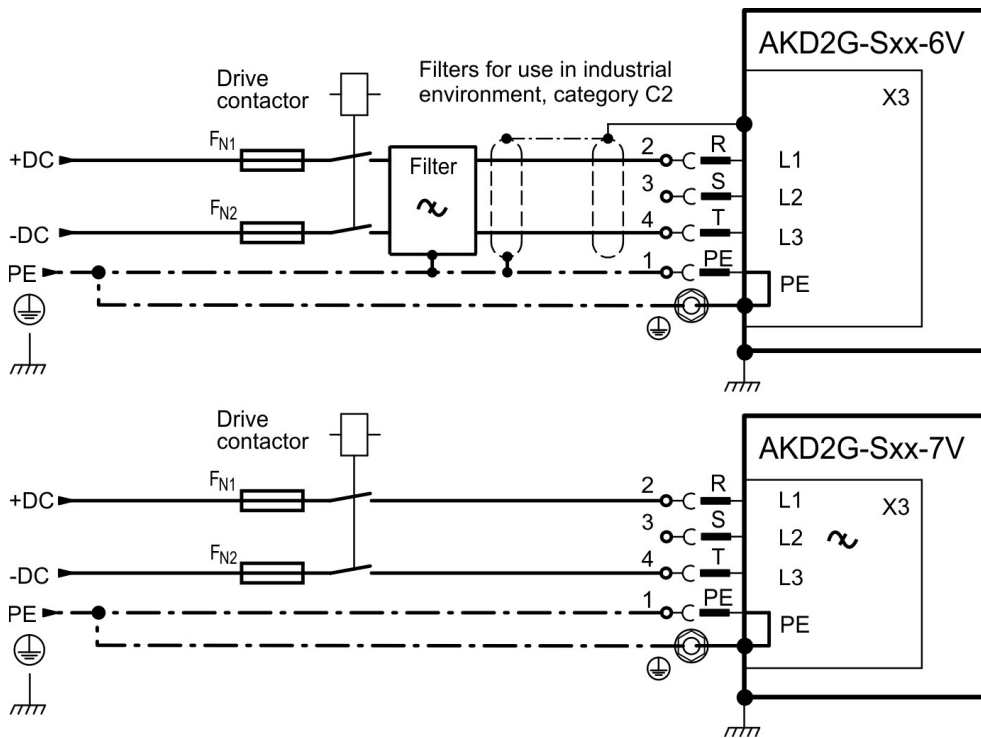

DC Supply to DC Bus lines X3/7-8

NOTICE

When wiring DC power supply to the drive DC Bus terminals X3 pins 7 and 8, the user is responsible for current and power management using additional external devices. For more information refer to [KDN \(AKD2G Low Voltage DC Operation\)](#).

User responsibility:

- The power supply system design must ensure inrush current protection by limiting input current during power up.
- Provide a means to safely absorb energy from the motor when slowing down/regenerating. If the DC power source is a battery energy absorption should just work.
- DC supply polarity must be properly wired. Improper polarity of DC power will damage the drive and void warranty.

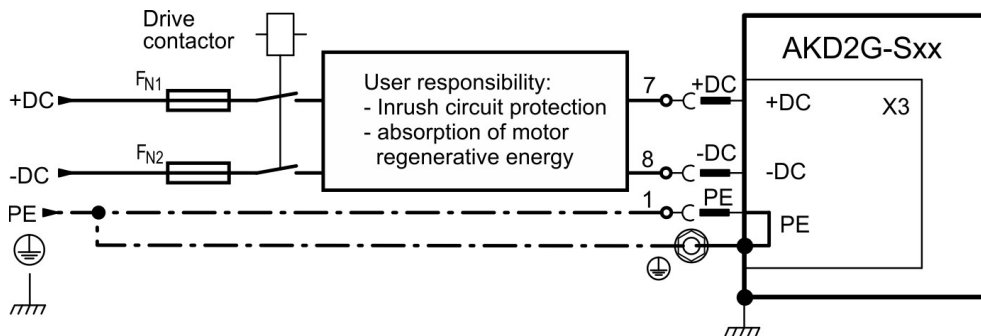

8.6.1.2 Fusing

Fuse types

- UL fuses: Class J, 600 VAC 200 kA (SCCR rating), time-delay. The fuse must be UL and CSA listed, UL recognized is not sufficient. Alternate fuses and breakers to Class J must have similar or better I_p and I^2T performance per UL 508A SB4.2 at the necessary SCCR rating.
- CE fuses: types gS or gG, 400 V/500 V, time-delay
- Fuse holders: Combined with the standard fuse blocks, finger safe fuse holders must be used according to IEC 60529.
- Automatic circuit breakers: max. rating is 30 A, observe SCCR rating
- Group installation fusing: max. rating of fuses or breakers for group installation is 30 A

AC supply, single drives, line fusing

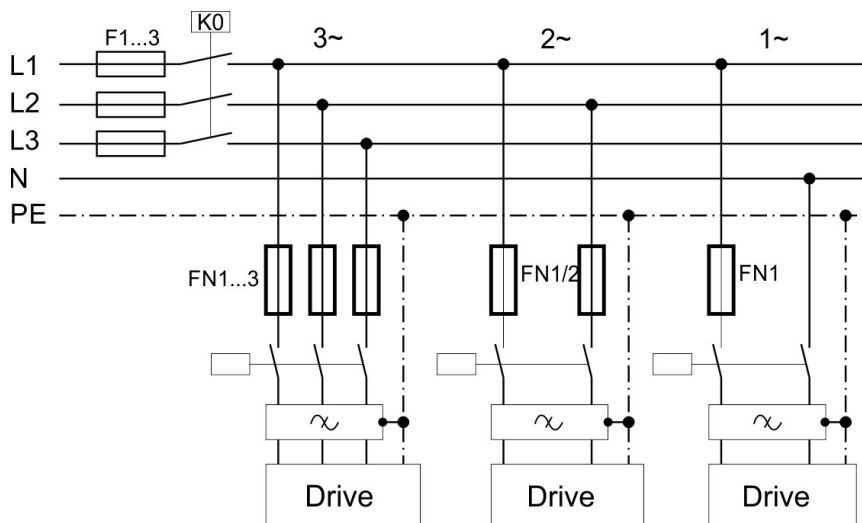

- F1, F2, F3: depends on sum of current and cabinet requirements.
- Filters for special EMC requirements only (→ # 278).
- FN1, FN2, FN3 maximum rating: 30 A.
- FN1, FN2, FN3 recommended rating see table below:

Drive Model	FN1, FN2, FN3: Ampere rating	Example class J Eaton Bussmann	Example class J Ferraz Shawmut
AKD2G-Sxx-6V03S	10 A (Time-Delay)	LPJ10SP/DFJ10	AJT10/HSJ10
AKD2G-Sxx-6V06S AKD2G-Sxx-6V03D	10 A (Time-Delay)	LPJ10SP/DFJ10	AJT10/HSJ10
AKD2G-Sxx-6V12S AKD2G-Sxx-6V06D	15 A (Time-Delay)	LPJ15SP/DFJ15	AJT15/HSJ15
AKD2G-Sxx-7V03S	10 A (Time-Delay)	LPJ10SP/DFJ10	AJT10/HSJ10
AKD2G-Sxx-7V06S AKD2G-Sxx-7V03D	10 A (Time-Delay)	LPJ10SP/DFJ10	AJT10/HSJ10
AKD2G-Sxx-7V12S AKD2G-Sxx-7V06D	15 A (Time-Delay)	LPJ15SP/DFJ15	AJT15/HSJ15

AC supply, group of drives, line fusing

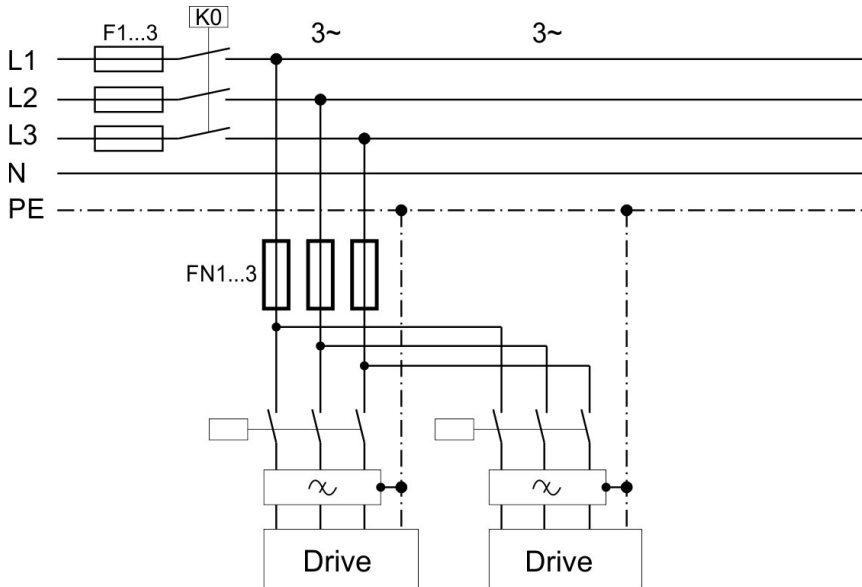

- F1, F2, F3: depends on sum of current and cabinet requirements.
- Filters for special EMC requirements only (→ # 278).
- FN1, FN2, FN3 maximum rating: fuse size for group installation is limited to 30 A max.
- FN1, FN2, FN3 rating should be $1.25 \cdot \text{sum current}$.

Group sum current	FN1, FN2, FN3: Ampere rating	Example class J Eaton Bussmann	Example class J Ferraz Shawmut
6 A to 30 A	30 A (Time-Delay)	LPJ30SP/DFJ30	AJT30/HJ30

AC supply, single drives, automatic circuit breakers

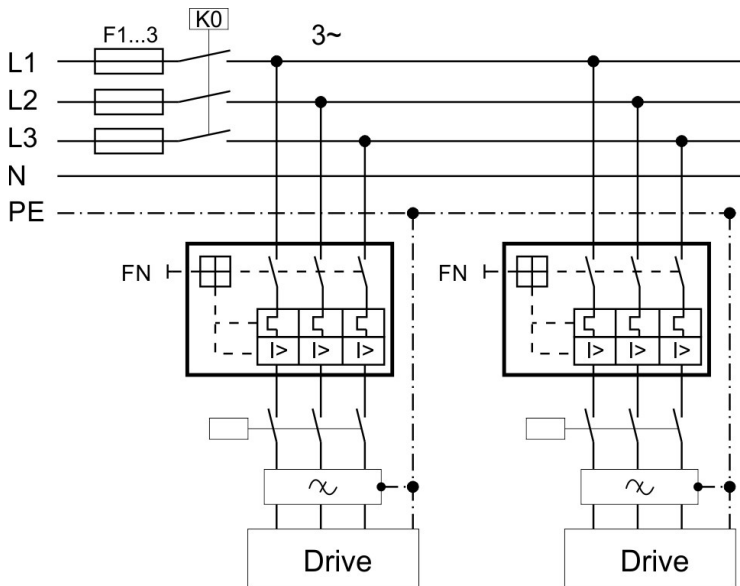

- F1, F2, F3: depends on sum of current and cabinet requirements.
- Filters for special EMC requirements only (→ # 278).
- FN maximum rating: 30 A
- FN recommended rating and regional approvals see table below:

Drive Model	Ampere rating	SCCR rating	Example UL Eaton or ABB	Example CE Siemens
AKD2G-Sxx-6V	15 A	35 kA	SU203M-K30	3VA51954EC310

AC supply, group of drives, automatic circuit breakers

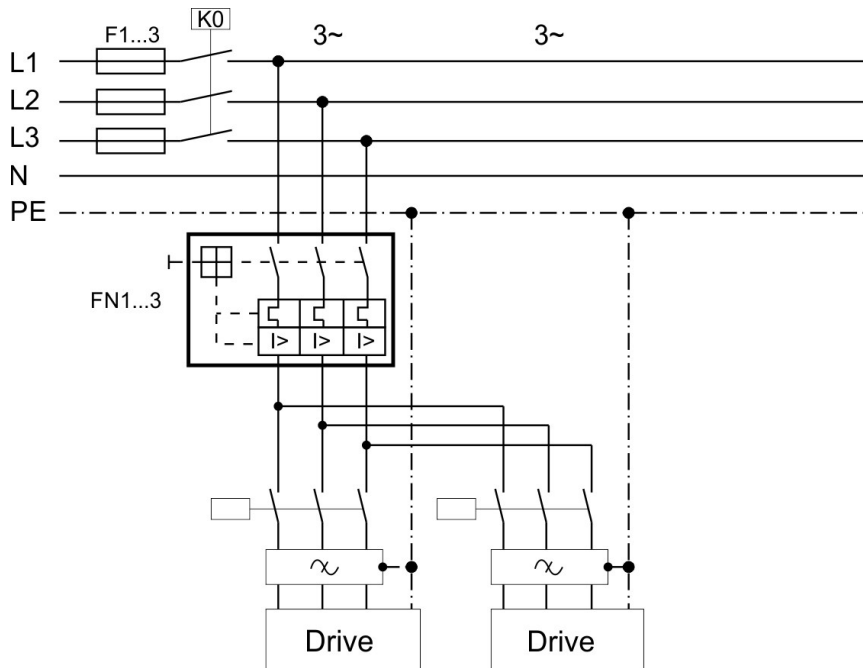

- F1, F2, F3: depends on sum of current and cabinet requirements.
- Filters for special EMC requirements only (→ # 278).
- FN maximum rating: circuit breaker size for group installation is limited to 30 A max.
- FN rating should be 1.25 * sum current.
- FN recommended rating and regional approvals see table below:

Group sum current	Ampere rating	SCCR rating	Example UL Eaton or ABB	Example CE Siemens
AKD2G-Sxx-6V				
6 A to 9A	15 A	10 kA	SU203M-K15	3VA51954EC310A
12 A to 15 A	20 A	10 kA	SU203M-K20	3VA51204EC310A
18 A to 24 A	30 A	10 kA	SU203M-K30	3VA51304EC310A
27 A to 36 A	30 A	10 kA	SU203M-K30	3VA51304EC310A

DC supply, single drives, line fusing

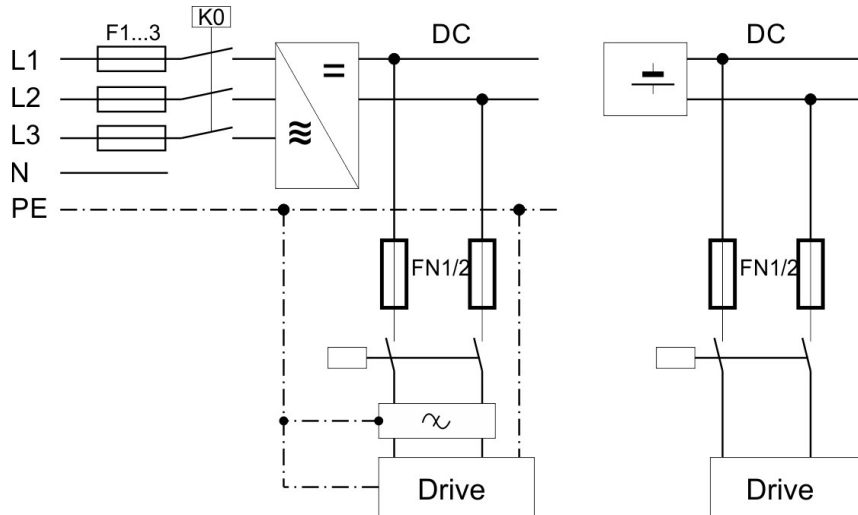

- F1, F2, F3: depends on sum of current and cabinet requirements.
- Filters for special EMC requirements only (→ # 278).
- FN1, FN2 maximum rating 30 A
- FN1, FN2 recommended rating see table below:

Drive Model	Ampere rating	Example UL Eaton Bussmann	Example CE Mersen
AKD2G-Sxx-6V03S	10 A (Time-Delay)	DFJ-10	HP6M10
AKD2G-Sxx-6V06S AKD2G-Sxx-6V03D	15 A (Time-Delay)	DFJ-15	HP6M15
AKD2G-Sxx-6V12S AKD2G-Sxx-6V06D	15 A (Time-Delay)	DFJ-15	HP6M15
AKD2G-Sxx-7V03S	10 A (Time-Delay)	FWP-10B	HP10M10
AKD2G-Sxx-7V06S AKD2G-Sxx-7V03D	10 A (Time-Delay)	FWP-10B	HP10M10
AKD2G-Sxx-7V12S AKD2G-Sxx-7V06D	15 A (Time-Delay)	FWP-15B	HP10M15

8.6.2 Auxiliary voltage power supply connector X10

The following diagram describes external 24 VDC power supply (PELV). The required supply current rating depends on the use of motor brake (→ # 35) or (→ # 37).



- 2 pin, pitch 5.08 mm
- T-type mating connector data (→ # 51)
- Undervoltage fault limit 19 V
- Overvoltage fault limit 30 V

Pin	Signal	Description
1	+ 24 V	+24 VDC supply voltage, PELV
2	GND	Ground for 24 VDC supply voltage, PELV

24 V supply (PELV)	Units	Input data
Auxiliary voltage supply (PELV)	VDC	24 V (±10%, check voltage drop)
- control current without motor brake	A	< 1
- control current with one motor brake	A	< 3.1
- control current with two motor brakes	A	< 5.2

8.6.2.1 Fusing

Use 24 VDC supply manufacturers recommendation for fusing.

8.6.2.2 Wiring example 24 VDC supply

Maximum current for one string of daisy-chained X10T connectors is 20 A. The sum control current of connected drives should not extend 20 A. With the data given in the table above, you can connect for example:

6 single axis drives, or 4 dual axis drives, or 3 single + 2 dual axis drives.

Wiring example with three phase power supply unit:

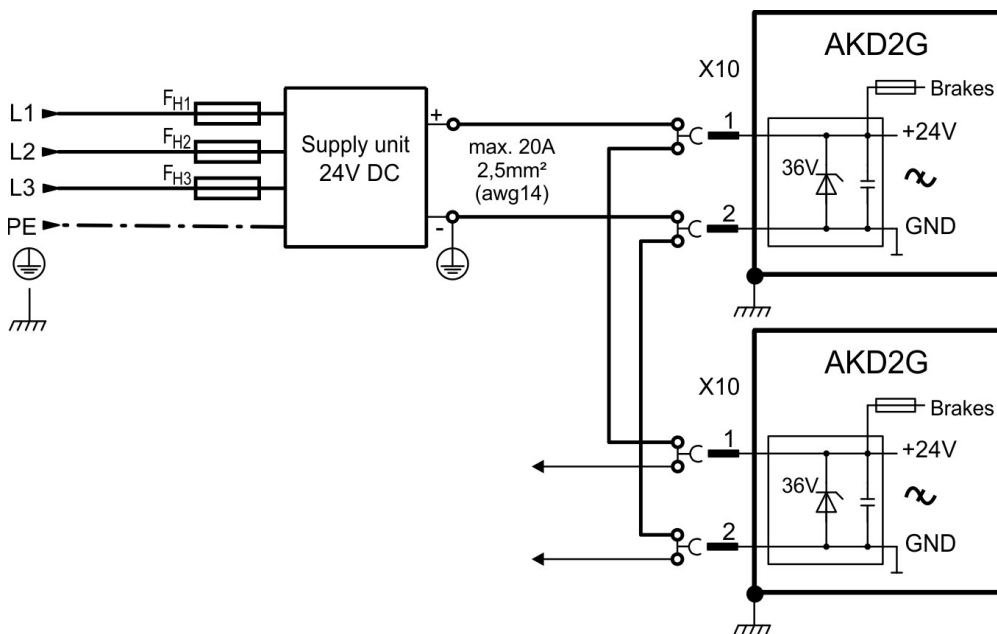

8.7 DC Bus link connector X3

The DC bus link can be connected in parallel so that the power returned from slowing down motors is divided between all the drives that are connected to the same DC bus link circuit. Every drive must have its own power connection to mains voltage sharing the same branch, over current protection devices, even if the DC bus link is used. Drives working generatively very often should be placed beside drives, which need energy. That reduces current flow on longer distances.

NOTE

The sum of the rated currents for all drives connected in parallel to an AKD2G must not exceed 48 A.

Examples: 12S-12S-12D-12D-12D or 06D-12S-12D-06D-06D-03S-03S-03S

Wiring: Use 6 mm² unshielded single cores with a max. length of 200 mm; use 6 mm² shielded cables for longer lengths. In this case no fuse for line protection is required.

NOTICE

The drives can be destroyed if DC bus link voltages are different. Only drives with mains supply that share the same AC branch, over current protection devices (identical mains supply voltage) may have the DC bus links interconnected.

Interconnection of DC bus links works best in systems powered by 3-phase AC or DC power. Consult Kollmorgen for DC bus linking with single phase AC power input.



- 8 pin, pitch 7.62 mm
- optional T version
- Mating connector data (→ # 51)

Pin	Label	Signal	Description
7	+DC	+DC	DC Bus link positive
8	-DC	-DC	DC Bus link negative

8.7.1 Fusing

External regen fusing FB1/FB2 (→ # 84). DC bus link fusing depends on topology (see (→ # 83)).

Wiring topology	Ampere rating@240V	Ampere rating@480V	UL region example Eaton:	CE Region example Mersen:
AKD2G-Sxx-6V				
Group: Fgroup	max. 30 A	na	DFJ-30	HP6M30
Busbar: Fbus	max. 15 A	na	DFJ-15	HP6M15
AKD2G-Sxx-7V				
Group: Fgroup	max. 30 A		FWP-30B	HP10M30
Busbar: Fbus	max. 15 A		FWP-15B	HP10M15

8.7.2 Wiring example with T connectors

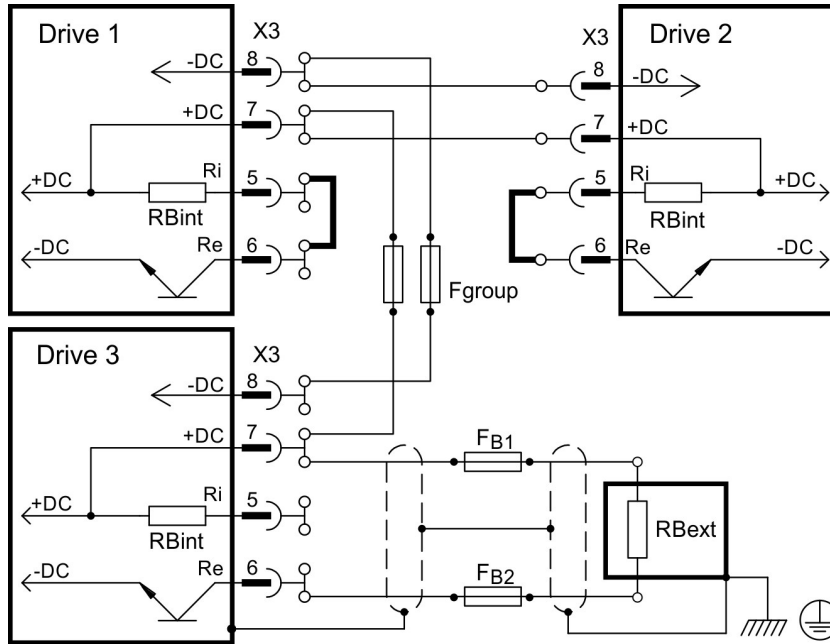

Without DC Bus fuses, other devices can become damaged or destroyed if, for example, a device fails due to an internal short circuit. If multiple drives are connected in parallel, then it is usual to insert DC Bus fuses (Fgroup) between groups of drives (with a group consisting of two or three devices, depending on the current) in order to limit any possible resulting damage. Fgroup fuses cannot avoid damage by current peaks completely.

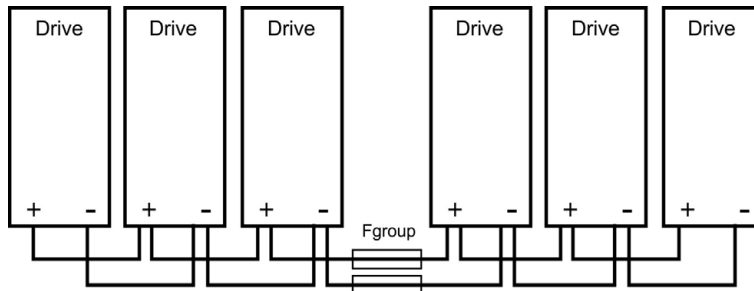

8.7.3 Wiring example with busbar

If a device fails in this system due to a short-circuit, only its fuses (Fbus) are tripped and the rest of the network continues uninterrupted. The solid busbars can conduct significantly larger currents than T connectors, because the compensating current does not flow through the connector as above.

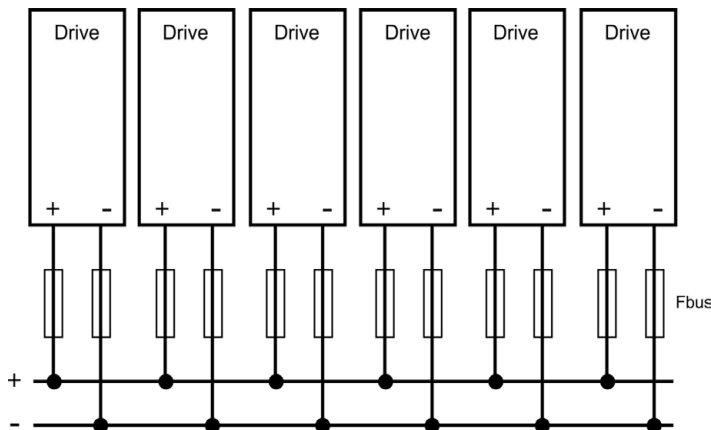

8.8 Regen resistor connector X3

For technical data on the regenerative brake circuit (→ # 39).

NOTE

Fusing (such as fusible cut-outs or power switches) to be provided by the user.



- 8 pin, pitch 7.62 mm
- optional T version
- Mating connector data (→ # 51).
- X3/5 to X3/6 must be shorted to use the built in regen resistor. Remove the jumper to connect an external regen resistor.
- Refer to the WorkBench online help for parameter setting (REGEN.EXT, REGEN.REXT, REGEN.WATTEXT)

Pin	Label	Signal	Description
5	Ri	RBint	internal Regen resistor
6	Re	-RB	external Regen resistor -
7	+DC	+RBext	external Regen resistor +

8.8.1 Fusing and Wiring

FB1 / FB2 fusing

Drive Model	Ampere rating@240V	Ampere rating@480V	UL region example:	CE Region example: Siba
all AKD2G-Sxx	10A	40A	Eaton FWP-xxA14F	110V to 400V: gRL(gS) 400V to 480V: aR

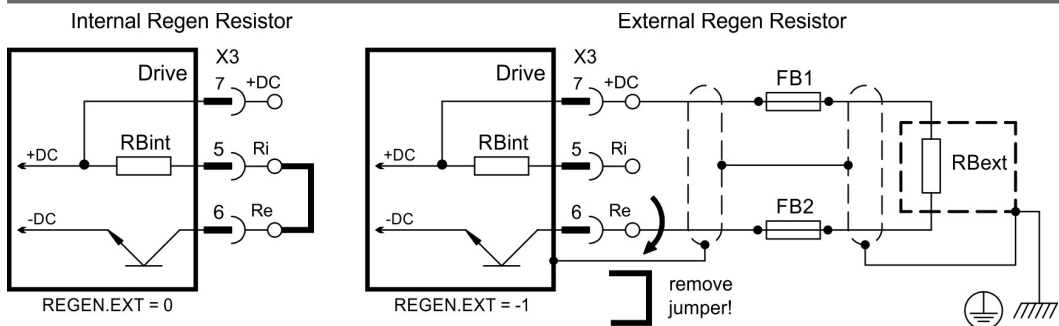

8.9 Motor Power, Brake and Feedback connection

The AKD2G drive is able to protect the connected motor from overloading, if the parameters are set correctly and the thermal protection sensor is connected and supervised. With Kollmorgen motors the valid data are automatically set by the WorkBench motor database. Refer to parameter AXIS#.MOTOR.RTYPE for supported thermal sensors.

NOTICE

The dynamic voltage rise can lead to a reduction in the motor operating life and, on unsuitable motors, to flashovers in the motor winding.

- Only install motors with insulation class F (acc. to IEC60085) or above.
- Only install cables that meet the requirements (→ # 52).

8.9.1 Motor connectivity, some examples

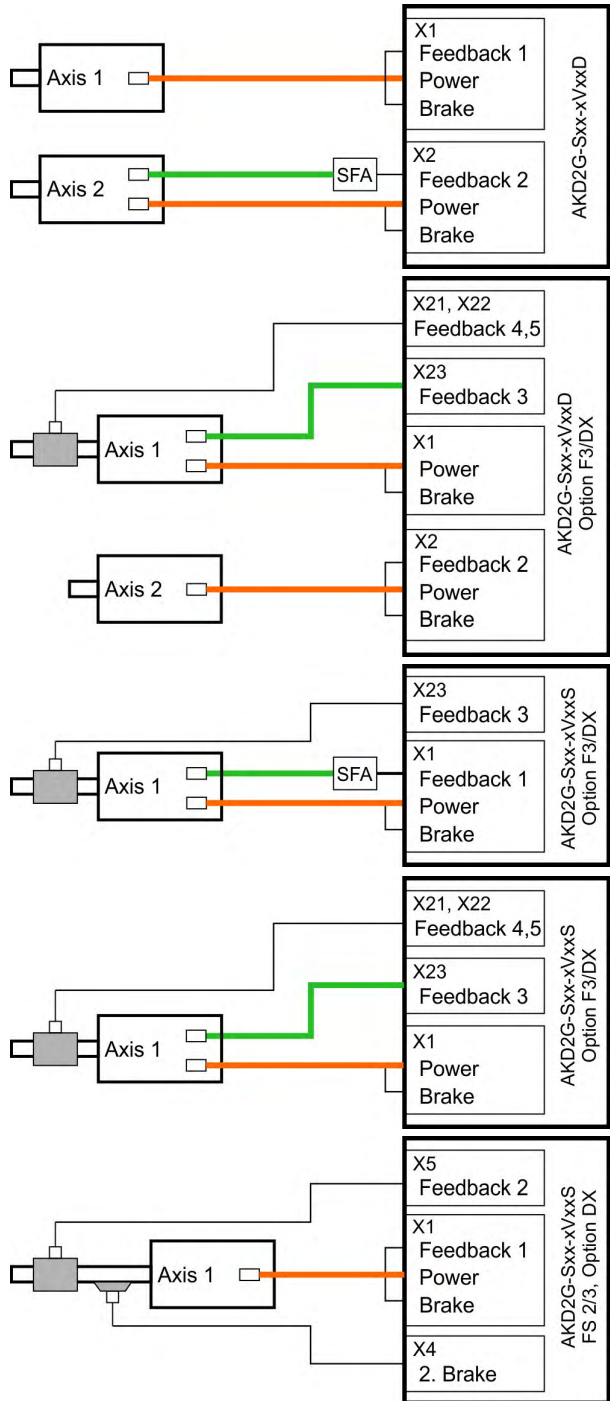

- Axis 1: single cable connection (→ # 85)
 - commutation feedback: SFD3 or DSL
- Axis 2: dual cable connection (→ # 85)
 - commutation feedback: EnDAT, HIPERFACE, Resolver etc. by using SFA

- Axis 1: dual cable connection (→ # 88)
 - commutation feedback: Resolver, SFD, EnDAT, HIPERFACE, BiSS, SinCos, ComCoder, Hall, SmartAbs etc. by using X23
 - position feedback:
 - X21: Step/Direction
 - X22: Step/Direction or incremental encoder
- Axis 2: single cable connection (→ # 85)
 - commutation feedback: SFD3 or DSL

- Axis 1: dual cable connection (→ # 88)
 - commutation feedback: EnDAT, HIPERFACE, Resolver etc. by using SFA
 - position feedback: Resolver, SFD, EnDAT, HIPERFACE, BiSS, SinCos, ComCoder, Hall, SmartAbs etc. by using X23

- Axis 1: dual cable connection (→ # 88)
 - commutation feedback: Resolver, SFD, EnDAT, HIPERFACE, BiSS, SinCos, ComCoder, Hall, SmartAbs etc. by using X23
 - position feedback:
 - X21: Step/Direction
 - X22: Step/Direction or incremental encoder

- Axis 1: single cable connection (→ # 85)
 - commutation feedback: SFD3 or DSL
 - position feedback: SFD3 or DSL or SFA at X5
 - secondary brake by using X4

8.9.2 Motor single cable connection

Motors with two wire feedback systems like SFD3 or Hiperface DSL can be connected to AKD2G by using a single Kollmorgen hybrid cable. Depending on the AKD2G version (single or dual axis), one or two single cable motor connections are possible.

Drive type	Commutation Axis 1	Commutation Axis 2	2nd Brake	Velocity/Position loop closure
Single axis with Option F3	X1	-	X4	X5 X21 X22 X23
Dual axis with Option F3	X1	X2	-	- X21 X22 X23

8.9.2.1 Motor Power, Brake and Feedback connectors X1, X2

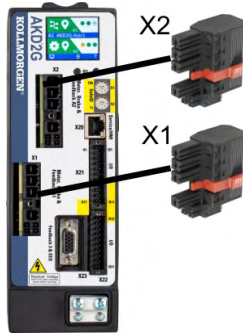

- X1 (Feedback 1) / X2 (Feedback 2)
 - Motor Power: 4 pin, pitch 7.62 mm
 - Motor Brake: 2 pin, pitch 3.81 mm
 - Motor Feedback: 2 pin, pitch 3.81 mm
- Cable length: (→ # 52)
- Use Kollmorgen cables
- Mating connector data (→ # 51).
- Feedback types: SFD3, HIPERFACE DSL
 - Rated voltage 11 V.
 - Rated current is 350 mA simultaneously for X1 and X2.

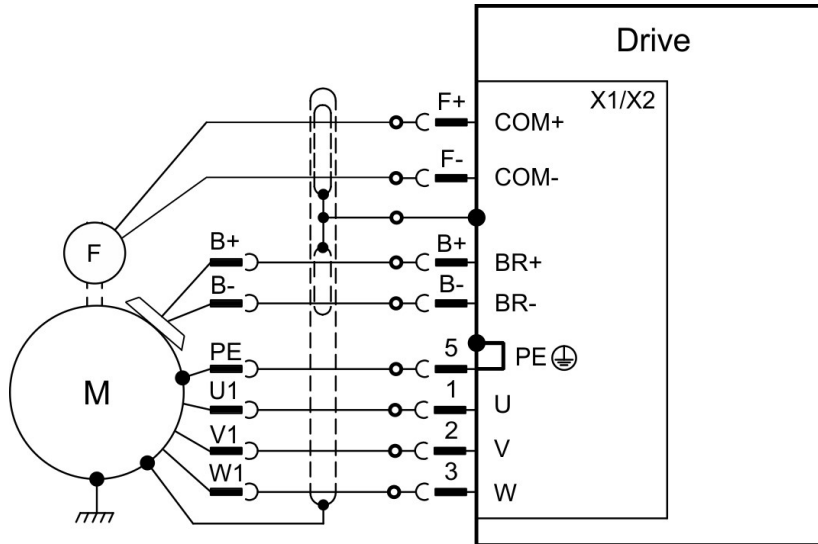

Pinout is identical for connectors X1 and X2.

Pin	Signal	Description
1	U	Motor phase U
2	V	Motor phase V
3	W	Motor phase W
5	PE	Protective earth
B+	BR+	Brake positive line (safety notes and details (→ # 91))
B-	BR-	Brake negative line (safety notes and details (→ # 91))
F+	COM+	SFD3, HIPERFACE DSL
F-	COM-	

8.9.2.2 Feedback connectors X5, X41, X21, X22, X23

- Velocity/Position loop closing
- Use Kollmorgen cables
- Mating connector data (→ # 51).
- Cable length: (→ # 52)

Connector	Functionality	Pinout, Wiring
X5	For single axis drives only. SFD3, DSL, SFA	(→ # 96)
X41	SFA at X5, several conventional feedback types	(→ # 100)
X21	Step/Direction, CW/CCW	(→ # 97)
X22	Step/Direction, CW/CCW, Incr.Encoder, EnDAT, BiSS	(→ # 98)
X23	Several conventional feedback types	(→ # 99)

8.9.2.3 Secondary Brake connector X4

Connector X4 is part of single axis drives. Use for applications, which require a second safe brake for functional safety.

- Mating connector data (→ # 51).
- Cable length: (→ # 52)

Connector	Functionality	Pinout, Wiring
X4	For single axis drives only	(→ # 93)

8.9.3 Motor dual cable connection

Motors with conventional commutation feedback systems like resolver or sine encoder can be connected to AKD2G with separated power/brake and feedback cables. Feedback functions are assigned with parameters in WorkBench. Scaling and other settings are performed in WorkBench, too. Velocity / Position loop closing and electronic gearing / master-slave connection are possible by using X5, X21, X22, X23 depending on the drive version and physical restrictions.



- X1 (Feedback 1) / X2 (Feedback 2)
 - Motor Power: 4 pin, pitch 7.62 mm
 - Motor Brake: 2 pin, pitch 3.81 mm
 - SFA connection: 2 pin, pitch 3.81 mm
 - Feedback types: see SFA connectivity (→ # 100)
- X23 (Feedback 3)
 - SubD HD 15 poles
 - Feedback types: see X23 connectivity (→ # 99)
- X21 (Feedback 4)
 - 2 x 11 pins (left connector A, right connector B)
 - Feedback types: see X21 connectivity (→ # 97)
- X22 (Feedback 5)
 - 2 x 10 pins (left connector A, right connector B)
 - Feedback types: see X22 connectivity (→ # 98)
- Mating connector data (→ # 51).

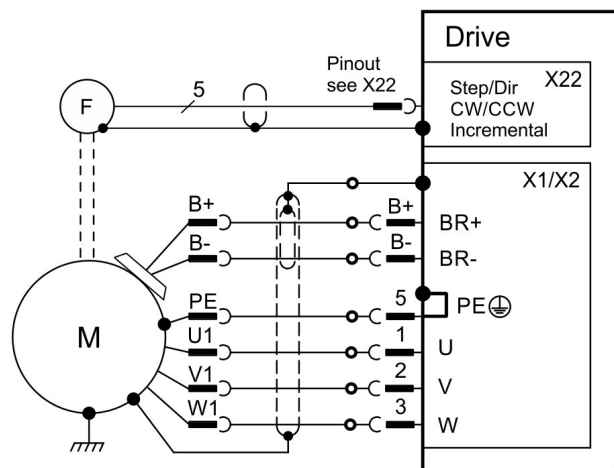
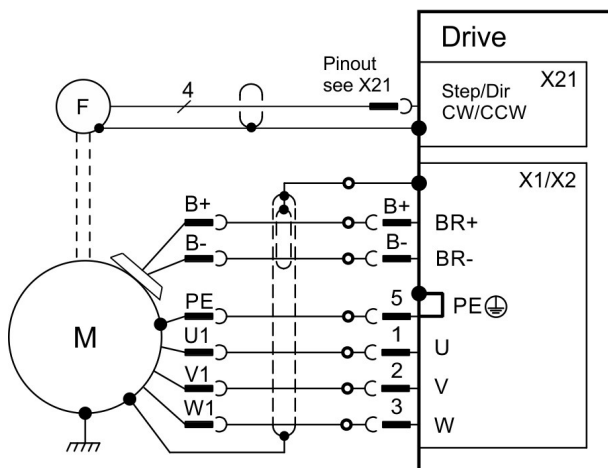
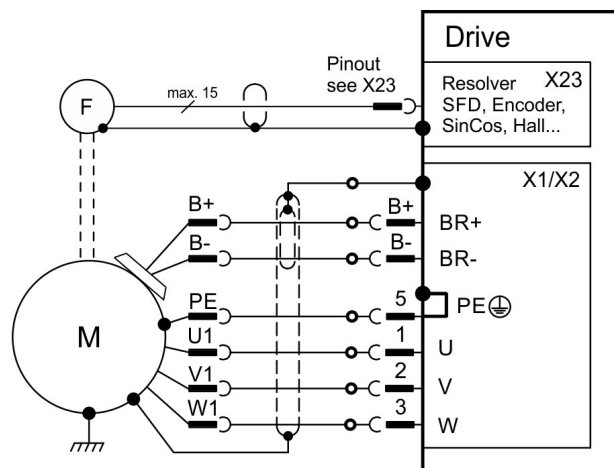
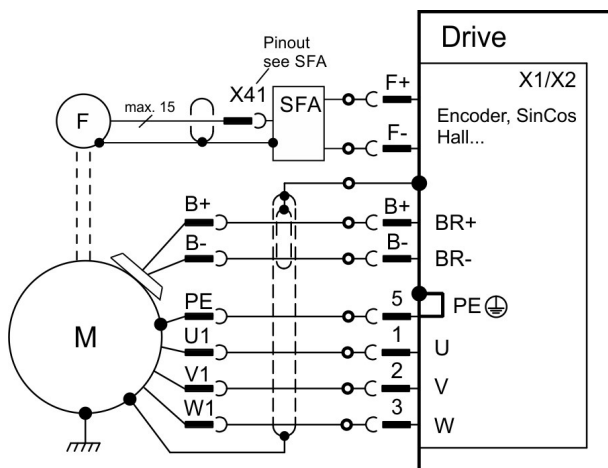

8.9.3.1 Motor power and motor brake connectors X1, X2

Usually these lines are part of the Kollmorgen motor cable connected to X1 or X2. For motor brake safety notes and functional details (→ # 91).

- Use Kollmorgen cables
- Mating connector data (→ # 51).
- Cable length: (→ # 52)

Pin	Signal	Description
1	U	Motor phase U
2	V	Motor phase V
3	W	Motor phase W
5	PE	Protective earth
B+	BR+	Brake positive, with Kollmorgen cables only
B-	BR-	Brake negative, with Kollmorgen cables only

8.9.3.2 Feedback connectors X1, X2, X5, X41, X21, X22, X23

- Use Kollmorgen cables
- Mating connector data (→ # 51).
- Cable length: (→ # 52)
- For feedback connection overview (→ # 94)

Connector	Functionality	Pinout, Wiring
X1/X2	SFD3, DSL, SFA	(→ # 95)
X5	For single axis drives only. SFD3, DSL, SFA	(→ # 96)
X41	SFA at X1 or X2 or X5, several conventional feedback types	(→ # 100)
X21	Step/Direction, CW/CCW	(→ # 97)
X22	Step/Direction, CW/CCW, Incr. Encoder, EnDAT, BiSS	(→ # 98)
X23	Several conventional feedback types	(→ # 99)

Feedback connector X1, X2, X5, X41

Conventional feedback systems can be connected to X1 or X2 or X5 by using the optional feedback adapter SFA. SFA offers the additional connector X41.

- Connector X1 is a standard connector. Input for SFD3, DSL, or SFA.
- Connector X2 is standard for dual-axis drives. Input for SFD3, DSL, or SFA.
- Connector X5 is optional for single axes drives. Input for SFD3, DSL, or SFA.
- SFA: adapter for several conventional feedback types

Feedback connector X21

- Connector X21 is a standard connector.
- Input for Step/Direction and CW/CCW.

Feedback connector X22

- Connector X22 is standard connector .
- Input for Step/Direction, CW/CCW, Incremental encoder

Feedback connector X23

- Connector X23 is part of option F3.
- Input for several conventional feedback types.

8.9.3.3 Secondary Brake connector X4

Connector X4 is part of single axis drive. Use for applications, which require a second safe brake for functional safety.

- Mating connector data: (→ # 51).
- Cable length: (→ # 53)

Connector	Functionality	Pinout, Wiring
X4	For single axis drives only	(→ # 93)

8.9.4 Motor Holding Brake Connection

A 24 V holding brake in the motor can be controlled directly by the drive. For proper function, check voltage drop, measure voltage at brake input and check brake function (on and off).

Brake voltage supply by using 24 V \pm 10% auxiliary voltage supply of the drive on X10. Minimum and maximum brake current see Electrical Data (\rightarrow # 36) respectively (\rightarrow # 38).

AKD2G offers motor brake outputs on connectors X1, X2 and X4. The outputs can be mapped to the required axis with WorkBench.

Connector	Usable for
X1	Primary motor brake axis 1 or secondary brake for axis 2
X2	Primary motor brake axis 2 or secondary brake for axis 1
X4	Secondary motor brake axis 1, for single axis drives only (\rightarrow # 93)



⚠ WARNING No functional safety!

Serious injury could result when the load is not properly blocked. The internal brake function does not ensure functional safety.

- Functional Safety can be ensured with configured SBC (\rightarrow # 171) only.
- For SIL 3 a second (external) motor brake for an axis is required. For single axis drives this brake can be connected to X4 (\rightarrow # 93). For dual axis drives the additional brake must be controlled from another source (e.g. from the other axis or externally from a safety controller). The brakes can be mapped to an axis with WorkBench.
- The Hardware Enable does not initiate a controlled stop but switches off the power stage immediately.
- Set parameter `AXIS#.MOTOR.BRAKEIMM` to 1 with vertical axes, to apply the brake immediately after faults or Hardware Disable.

Pinout X1 / X2

Pin	Signal	Description
B+	BR+	Brake positive line
B-	BR-	Brake negative line

Wiring

Usually the brake lines are part of the Kollmorgen hybrid single cable connection to X1 respectively X2 (\rightarrow # 85).

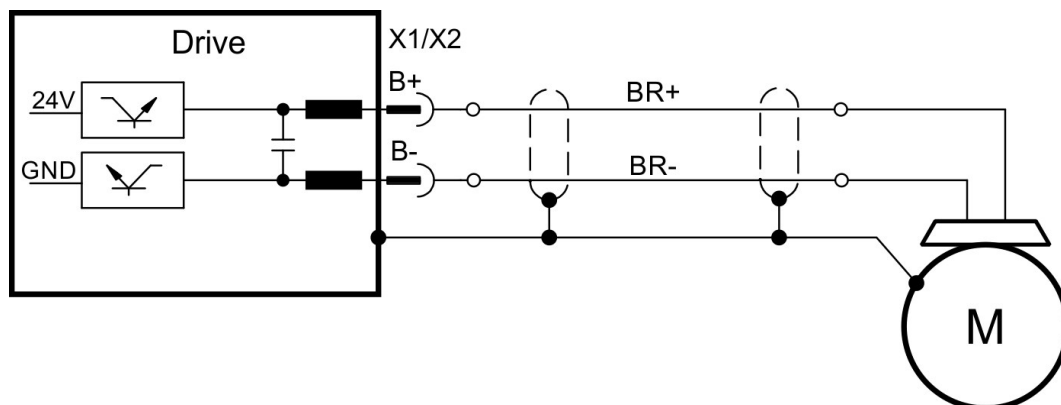

Functionality

The brake function must be enabled through a parameter. The diagram below shows the timing and functional relationships between the controlled stop signal, speed, and braking force. All values can be adjusted with parameters; values in the diagram are default values.

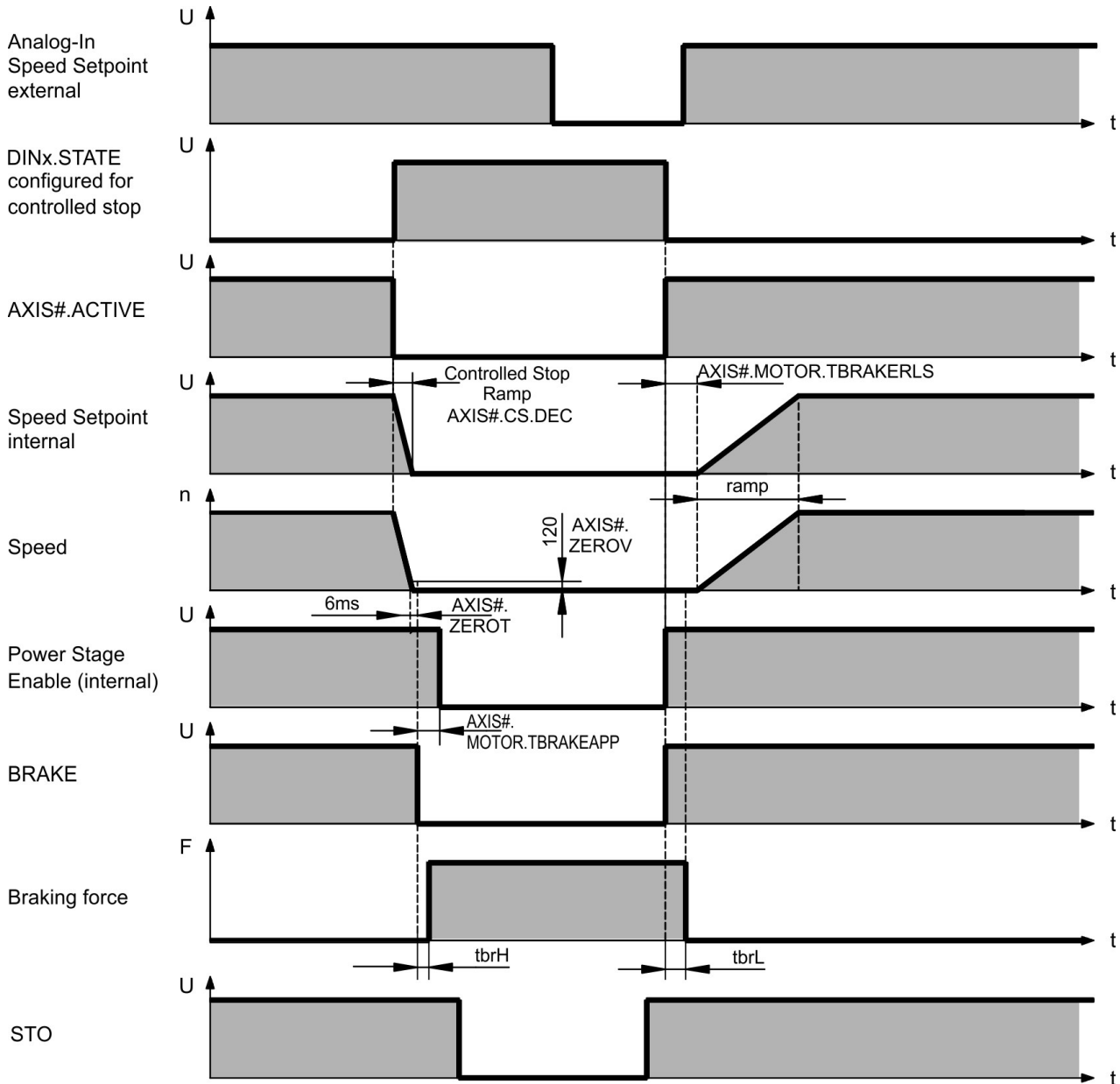

The drive speed setpoint is internally driven down an adjustable ramp (AXIS#.CS.DEC) to 0 V.

With default values the output for the brake is switched on when the speed has reached 5 rpm (AXIS#.ZEROV) for at least 6 ms (AXIS#.ZEROT). The rise (t_{brH}) and fall (t_{brL}) times of the holding brake that is built into the motor are different for the various types of motor.

8.9.4.1 Secondary Brake connector X4

Connector X4 is part of the single axis drives. Use for applications, which require a second safe brake for functional safety.



- 3 pin, pitch 3.81 mm
- Second (safe) motor brake
- Required for SIL3 brake control
- Mating connector data (→ # 51).

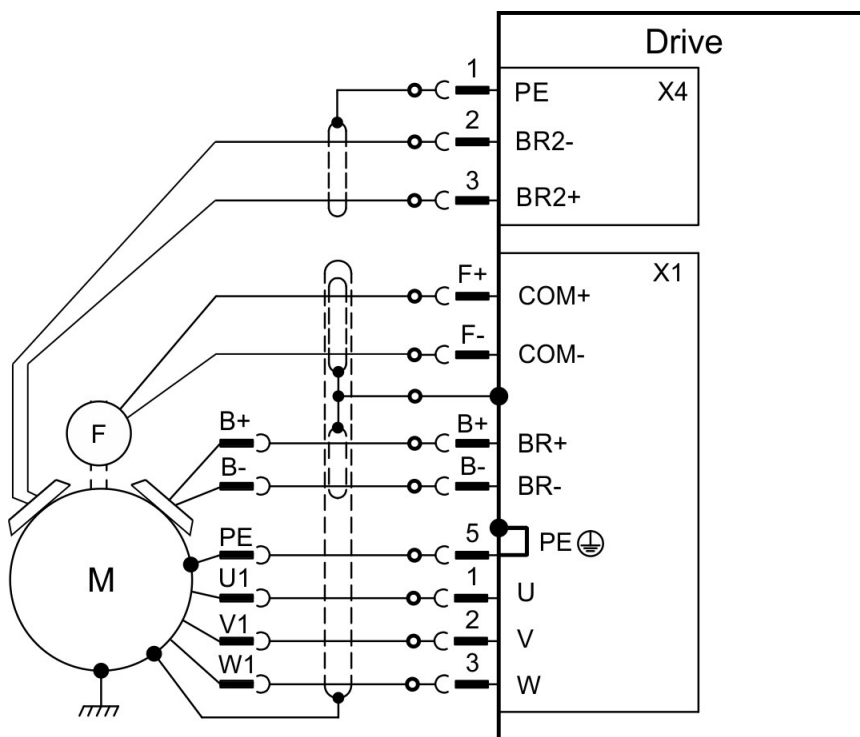

X4 Pin	Signal	Description
1	PE	Protective earth
2	BR2-	Second (external) brake -
3	BR2+	Second (external) brake +

8.9.5 Feedback Connection

AKD2G offers up to five feedback channels. These channels can serve

- to commute the motor (single cable (→ # 85) or dual cable (→ # 91)),
- to close the velocity and/or position loops, and
- to act as a command source (electronic gearing, flying sheer, master-slave (→ # 101)).

The usage of the five channels may be freely configured in software, subject only to a few restrictions that are not physically sensible.

- Exactly one feedback channel per axis can commute the motor.
- At most one feedback channel per axis can serve as the command source and the same feedback channel cannot also commute the motor.
- A feedback channel can serve as the command source for more than one axis.
- FB1 cannot commute axis 2. FB2 cannot commute axis 1.

Feedback channel	Connector	Usable for	Pinout
Feedback 1	X1	Axis 1: commutation feedback	(→ # 95)
	X41	Axis 1 by using SFA on X1: commutation feedback	(→ # 100)
Feedback 2	X2	Axis 2: commutation feedback	(→ # 95)
Feedback 2	X41	Axis 2 by using SFA on X2: commutation feedback	(→ # 100)
Feedback 2	X5	Single axis drive: velocity/position, command, safety	(→ # 96)
Feedback 2	X41	Single axis drive using SFA on X5: velocity/position, command, safety	(→ # 100)
Feedback 3	X23	commutation feedback, velocity/position, command	(→ # 99)
Feedback 4	X21	commutation feedback, velocity/position, command	(→ # 97)
Feedback 5	X22	commutation feedback, velocity/position, command	(→ # 98)

Feedback Types	Connectors
SFD3	X1, X2, X5
Encoder HIPERFACE DSL	X1, X2, X5
Resolver	X23, X41
SFD	X23, X41
SinCos Encoder BiSS B (analog)	X22, X23, X41
Encoder BiSS C (digital)	X22, X23
SinCos Encoder EnDat 2.1	X23, X41
Encoder EnDat Digital 2.2	X22, X23, X41
Encoder HIPERFACE	X23, X41
Sine Encoder	X23, X41
Sine Encoder + Hall	X23, X41
Incremental Encoder	X22, X23, X41
Incremental Encoder + Hall (Comcoder)	X23, X41
Hall Sensors	X23, X41
SSI	X22, X23
Step/Direction	X21, X22, X23, X41
CW/CCW	X21, X22, X23, X41

8.9.5.1 Feedback Connectors X1, X2

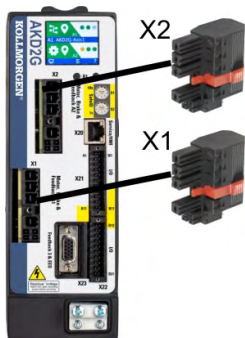

- 4 pin, pitch 7.62 mm plus 2x2 pin pitch 3.81 mm
- Input for commutation feedback: SFD3, DSL, SFA

Wiring example SFD3 or HIPERFACE DSL

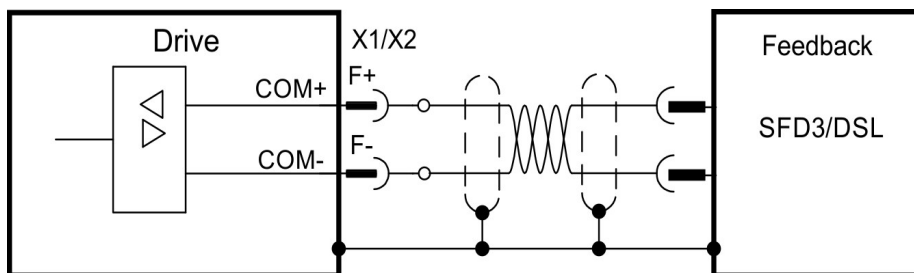

Wiring example conventional Feedback types with SFA

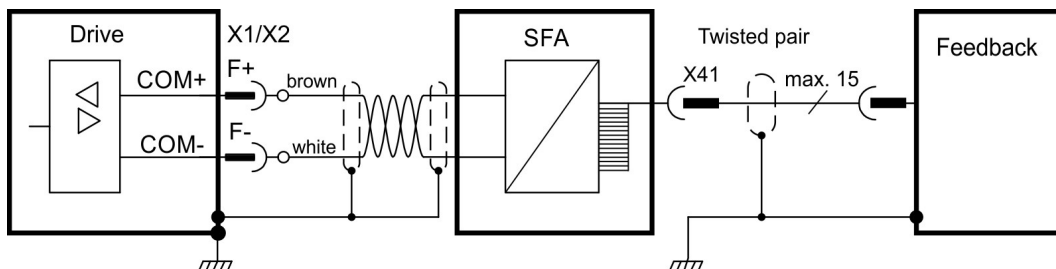

Electrical data

- Rated voltage 11 V.
- Rated current is 350 mA simultaneously for X1 and X2.

Pin	Signal	Description
F+	COM+	SFD3 +, HIPERFACE DSL +, SFA +
F-	COM-	SFD3 -, HIPERFACE DSL -, SFA -

8.9.5.2 Feedback Connector X5

Connector X5 is part of the single axis drives. Use this input for applications, which require a safe feedback.

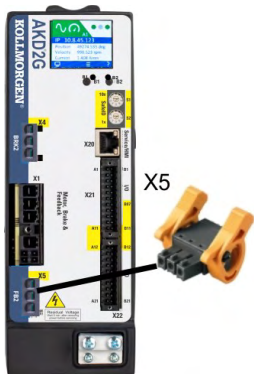

- 3 pin, pitch 3.81 mm
- Second 2 wire feedback, SFA
- Input for safe feedback.
- Feedback types: SFD3, HIPERFACE DSL
- Required for SIL3 feedback control
- Mating connector data (→ # 51).

Wiring example SFD3 or HIPERFACE DSL

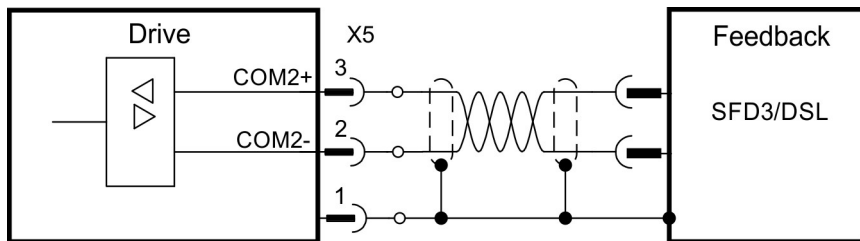

Wiring example conventional Feedback types with SFA

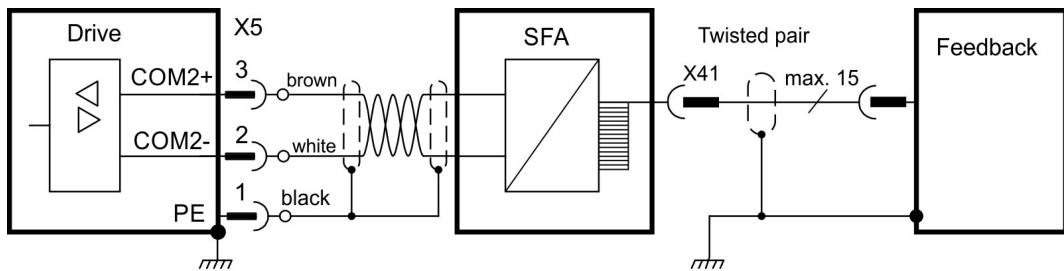

X5 Pin	Signal	Description
1	PE	Cable shield (PE)
2	COM2-	Safe HIPERFACE DSL - or SFD3 - or SFA-
3	COM2+	Safe HIPERFACE DSL + or SFD3 + or SFA+

8.9.5.3 Feedback Connector X21



- 2 x 11 pins (left connector A, right connector B), pitch 3.5 mm
- Fast input, isolated, sink, type EN 61131-2 type 1
- Input for commutation or position feedback.
- Input for Electronic Gearing, (→ # 101)
- Mating connector data (→ # 51).

Wiring example

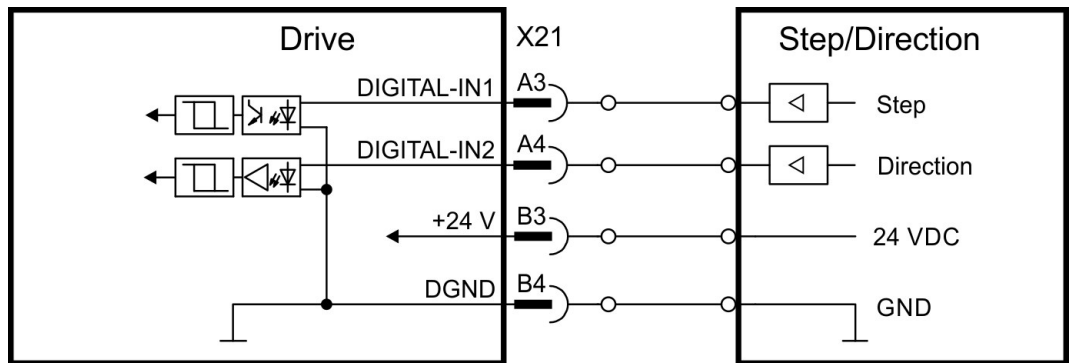

X21 Pin	Step/Direction	CW/CCW
A3	Step	CW
A4	Direction	CCW
B3	24 VDC	24 VDC
B4	Common (DGND)	Common (DGND)

8.9.5.4 Feedback Connector X22



- 2 x 10 pins (left connector A, right connector B), pitch 3.5 mm
- RS485 inputs
- Input for commutation or position feedback.
- Input for Electronic Gearing, (→ # 101)
- Output for encoder emulation (EEO2), (→ # 101)
- Mating connector data (→ # 51).

Wiring example (Input)

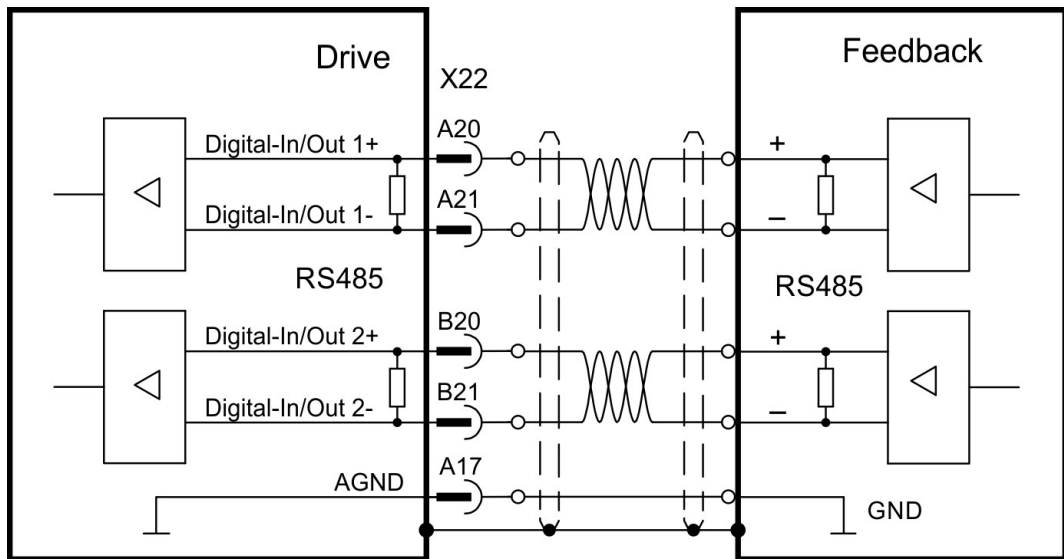

EEO output connection is similar.

X22 Pin	Step / Direction	CW / CCW	Increm. Encoder	BiSS B / C	EnDAT 2.2	s
A20	Step +	CW +	Track A +	CLK+	CLK+	CLK+
A21	Step -	CW -	Track A -	CLK-	CLK-	CLK-
B20	Direction +	CCW +	Track B +	DAT+	DAT+	DAT+
B21	Direction -	CCW -	Track B -	DAT-	DAT-	DAT-
A17	AGND	AGND	AGND	AGND	AGND	AGND

NOTE

Feedback power supply must be supplied and controlled by the user.

8.9.5.5 Feedback Connector X23

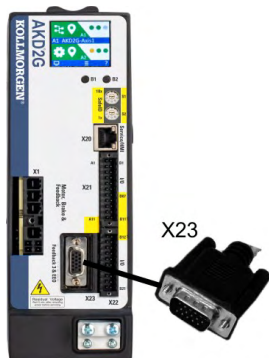

- Sub-D high density 15 pin, female
- Use Kollmorgen feedback cables
- Input for several feedback types
- Input for Electronic Gearing, (→ # 101)
- Output for encoder emulation (EEO1), (→ # 101)
- Digital input (→ # 116), Digital output (→ # 120)
- Mating connector data (→ # 51).

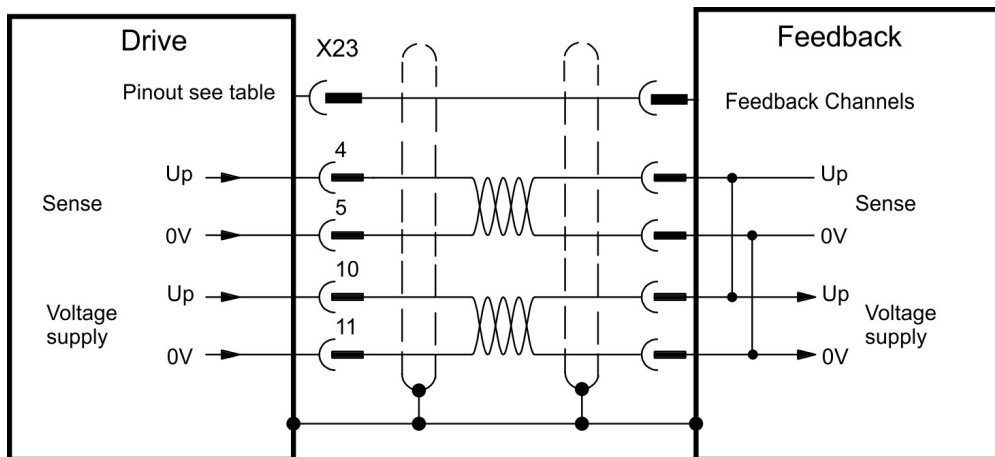

Encoder power supply (X23 pins 10/11):

- Maximum voltage 9 V with shorted sense contacts (4/5), rated voltage 5 V +/-5%.
- Rated supply current is 350 mA.
- Voltage rise time ~4 ms with full load and 220 µF of capacitance.
- Encoder power lines capacitance 10 µF to 220 µF

X23 Pin	SFD	Resol- ver	BiSS		EnDat		HIPER- FACE	Sin / Cos	Sin / Cos +Hall	Incr. Enc.	Incr. Enc. +Hall	Hall	SSI	Step/ Dir	CW/ CCW
			B	C	2.1	2.2									
1	-	-	-	-	-	-	-	-	Hall U	-	Hall U	Hall U	-	-	-
2	-	-	CL+	CL+	CL+	CL+	-	-	Hall V	-	Hall V	Hall V	CL+	-	-
3	-	-	CL-	CL-	CL-	CL-	-	-	Hall W	-	Hall W	Hall W	CL-	-	-
4	S+	-	S+	S+	S+	S+	S+	S+	S+	S+	S+	-	-	-	-
5	S-	-	S-	S-	S-	S-	S-	S-	S-	S-	S-	-	-	-	-
6	COM+	R1 Ref+	D+	D+	D+	D+	D+	Z+	Z+	Z+	Z+	-	D+	-	-
7	COM-	R2 Ref-	D-	D-	D-	D-	D-	Z-	Z-	Z-	Z-	-	D-	-	-
8	-	Th+	Th+	-	Th+	-	Th+	Th+	Th+	Th+	Th+	Th+	-	Th+	Th+
9	-	Th-	Th-	-	Th-	-	Th-	Th-	Th-	Th-	Th-	Th-	-	Th-	Th-
10	+5 V	-	+5 V	+5 V	+5 V	+5 V	8 to 9 V	+5 V	+5 V	+5 V	+5 V	+5 V	+5 V	+5 V	+5 V
11	0 V	-	0 V	0 V	0 V	0 V	0 V	0 V	0 V	0 V	0 V	0 V	0 V	0 V	0 V
12	-	S1 SIN+	A+	-	A+	-	SIN+	A+	SIN+	A+	A+	-	-	Step+	CW+
13	-	S3 SIN-	A-	-	A-	-	SIN-	A-	SIN-	A-	A-	-	-	Step-	CW-
14	-	S2 COS+	B+	-	B+	-	COS+	B+	COS+	B+	B+	-	-	Dir+	CCW+
15	-	S4 COS-	B-	-	B-	-	COS-	B-	COS-	B-	B-	-	-	Dir-	CCW-

CL = CLOCK, D = DATA, S = SENSE, Th = Thermal control, Z = Zero

8.9.5.6 Feedback Connector X41 (SFA, accessory)

SFA (Smart Feedback Adapter) converts conventional feedback signals to a 2-wire serial signal. SFA can be laid into the cable duct or may be mounted to a DIN rail using a standard DIN rail clip.

SFA adds a 15 pole HD SubD female connector X41 to the system for connection of a Kollmorgen motor feedback cable (see *Kollmorgen 2G Cable Guide*). Dimensions (LxWxD): 88.6 x 55.6 x 21.2 (28.6 with rail clip). Order codes see regional Accessories Manual.

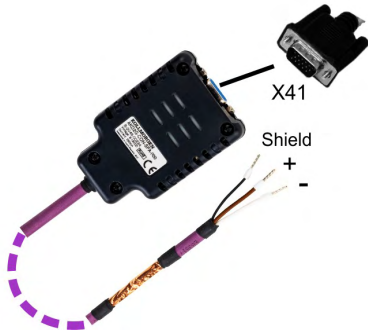

- Sub-D high density 15 pin, female
- 1 m shielded cable with 3 flying leads for connection to X1 or X2 or X5
- The cable shield is connected by using shield wire to X5/1 or with cable ties to the X1/X2 shield plates.
- Connected feedback must be set in WorkBench
- Use Kollmorgen feedback cables. The cable shield must be grounded on the end near the SFA.
- Input for Electronic Gearing, (→ # 101)
- Output for encoder emulation (EEO3/EEO4), (→ # 101)
- Master-Slave (→ # 103)

Connect the flying leads of the SFA cable to X1 (FB1, EEO3) or X2 (FB2, EEO4) or X5 (FB2, EEO4):

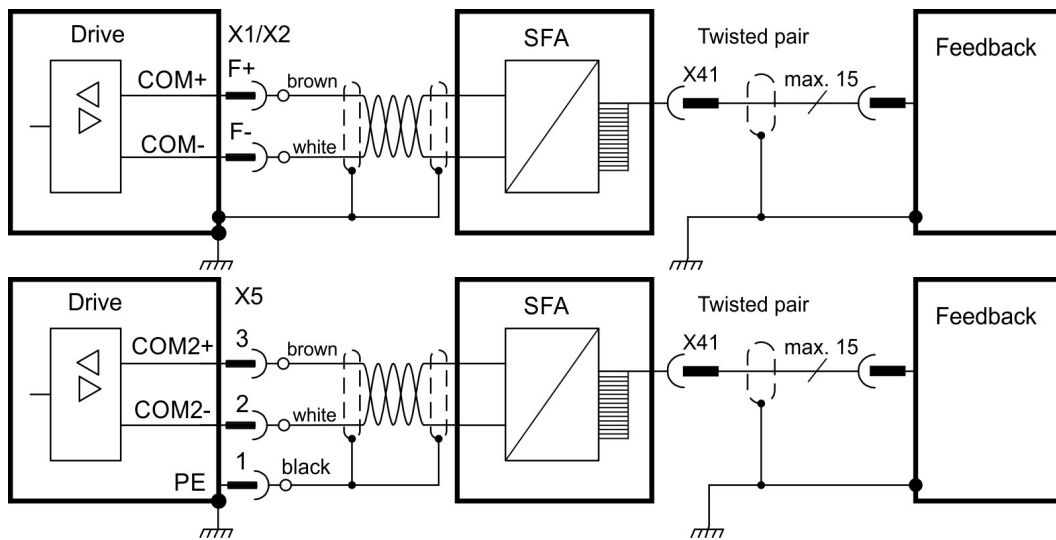

Operating Voltage: 7 V to 12 V, Maximum Load Current: 350 mA

X41 Pin	SFD	Resol- ver	BiSS B	EnDat 2.1	EnDat 2.2	HIPER-FACE	Sin / Cos	Si n / Cos +Hall	Incr. Enc.	Incr. Enc. +Hall	Hall	Step/ Dir	CW/ CCW
1	-	-	-	-	-	-	-	Hall U	-	Hall U	Hall U	-	-
2	-	-	CL+	CL+	CL+	-	-	Hall V	-	Hall V	Hall V	-	-
3	-	-	CL-	CL-	CL-	-	-	Hall W	-	Hall W	Hall W	-	-
4	S+	-	S+	S+	S+	S+	S+	S+	S+	S+	-	-	-
5	S-	-	S-	S-	S-	S-	S-	S-	S-	S-	-	-	-
6	COM+	R1 Ref+	D+	D+	D+	D+	Z+	Z+	Z+	Z+	-	-	-
7	COM-	R2 Ref-	D-	D-	D-	D-	Z-	Z-	Z-	Z-	-	-	-
8	-	Th+	Th+	Th+	-	Th+	Th+	Th+	Th+	Th+	Th+	Th+	Th+
9	-	Th-	Th-	Th-	-	Th-	Th-	Th-	Th-	Th-	Th-	Th-	Th-
10	+5 V	-	+5 V	+5 V	+5 V	8 to 9 V	+5 V	+5 V	+5 V	+5 V	+5 V	+5 V	+5 V
11	0 V	-	0 V	0 V	0 V	0 V	0 V	0 V	0 V	0 V	0 V	0 V	0 V
12	-	S1 SIN+	A+	A+	-	SIN+	A+	SIN+	A+	A+	-	Step+	CW+
13	-	S3 SIN-	A-	A-	-	SIN-	A-	SIN-	A-	A-	-	Step-	CW-
14	-	S2 COS+	B+	B+	-	COS+	B+	COS+	B+	B+	-	Dir+	CCW+
15	-	S4 COS-	B-	B-	-	COS-	B-	COS-	B-	B-	-	Dir-	CCW-

CL = CLOCK, D = DATA, S = SENSE, Th = Thermal control, Z = Zero

8.10 EEO, Electronic Gearing, Master-Slave

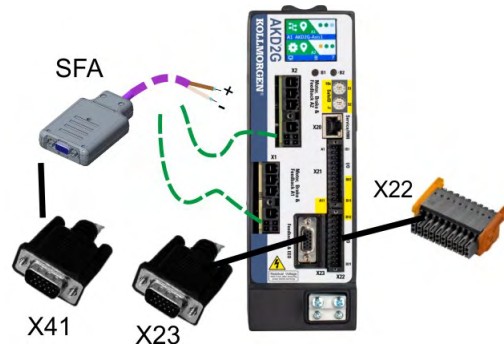

AKD2G offers up to 5 feedback channels, which may be used as the command source (input) for electronic gearing or master-slave or for EEO (Emulated Encoder Output).

Feedback channel	EEO channel	Connector	Pinout and wiring example	Parameter to configure the sensor type
Feedback 1	EEO3	X1	(→ # 95)	FB1.SELECT
		X41	(→ # 100)	
Feedback 2	EEO4	X2	(→ # 95)	FB2.SELECT
		X5	(→ # 96)	
		X41	(→ # 100)	
Feedback 3	EEO1	X23	(→ # 99)	FB3.SELECT
Feedback 4	N/A	X21	(→ # 97)	FB4.SELECT
Feedback 5	EEO2	X22	(→ # 98)	FB5.SELECT

8.10.1 Emulated Encoder Output (EEO)

The drive calculates the motor shaft position from the cyclic- absolute signals of the commutation feedback, generating incremental-encoder compatible pulses or CW/CCW signals or Pulse/Direction signals from this information.

The resolution and the index (zero) position can be set in WorkBench. The outputs are driven from an internal supply voltage. Refer to the WorkBench Online Help for more information.

NOTE

When using a multispeed resolver (more than 2 poles) as commutation feedback, the EEO will create only one zero pulse per each mechanical revolution of the motor. The zero pulse is dependent on the motors starting position!

NOTICE

EEO1-4 are NOT compatible with 24V signal level! Will be damaged if connected to +24V!

Technical characteristics connector X22, EEO2

Pulse outputs on the connector X22 are 2 signals, tracks A and B, with 90° phase difference (i.e. in quadrature, hence the alternative term “AquadB” output).

- RS-485, current 100 mA
- Max. number of connected slaves is determined by the loading characteristics of the slaves. 32 slaves can be driven if the input impedance of the bias network is 10kΩ and only one slave has a DC termination resistor.
- Max signal (channel) output frequency: 3 MHz
- The pulses per revolution value is settable, pulse phase shift: 90°±20°

X22	Signals EEO2	Description
A17	AGND	Analog ground
A20	Track A+	EEO2 output, channel A positive
A21	Track A-	EEO2 output, channel A negative
B20	Track B+	EEO2 output, channel B positive
B21	Track B-	EEO2 output, channel B negative

Technical characteristics connector X23, EEO1

Pulse outputs on the SubD connector X23 are 3 signals, A, B and Index, with 90° phase difference (i.e. AquadB), with a zero pulse.

- 5V TTL, current 60 mA
- Max. number of connected slaves is determined by the loading characteristics of the slaves, 32 slaves can be driven if the input impedance of the bias network is 10kΩ and only one slave has a DC termination resistor.
- Max signal (channel) output frequency: 3 MHz
- The pulses per revolution value is settable, pulse phase shift: 90°±20°

X23	Signals EEO1	Description
6	Zero+	EEO1 output, index positive
7	Zero-	EEO1 output, index negative
11	0 V	EEO1 output, ground
12	Track A+	EEO1 output, channel A positive
13	Track A-	EEO1 output, channel A negative
14	Track B+	EEO1 output, channel B positive
15	Track B-	EEO1 output, channel B negative

Technical characteristics connector X41 (SFA), EEO3/EEO4

Pulse outputs on the SubD connector X41 are 3 signals, A, B and Index, with 90° phase difference (i.e. "AquadB"), with a zero pulse.

If SFA is connected to X1, the logical output is EEO3.

If SFA is connected to X2 or X5, the logical output is EEO4.

- 5V TTL, current 60 mA
- Max. number of connected slaves is determined by the loading characteristics of the slaves, 32 slaves can be driven if the input impedance of the bias network is 10kΩ and only one slave has a DC termination resistor.
- Max signal (channel) output frequency: 3 MHz
- The pulses per revolution value is settable, pulse phase shift: 90°±20°

X41	Signals EEO3/EEO4	Description
6	Zero+	EEO3/EEO4 output, index positive
7	Zero-	EEO3/EEO4 output, index negative
11	0 V	EEO3/EEO4 output, ground
12	Track A+	EEO3/EEO4 output, channel A positive
13	Track A-	EEO3/EEO4 output, channel A negative
14	Track B+	EEO3/EEO4 output, channel B positive
15	Track B-	EEO3/EEO4 output, channel B negative

8.10.2 Electronic Gearing

AKD2G offers up to 5 feedback channels. Any of these channels may be used as the gearing command source. The gearing source is selected for each axis using `AXIS#.GEAR.FBSOURCE`. Refer to the WorkBench Online Help for more information.

8.10.3 Master-Slave control

Several AKD2G can be connected as slave drives to another AKD2G which acts as a master. The slave drives use the master's encoder output signal (EEO, (\rightarrow # 101)) as command input and follow these commands (velocity and direction).

8.10.3.1 Master-Slave using connector X22

The master is configured for EEO2 (\rightarrow # 101) on X22, the Slave uses X22 for command input.

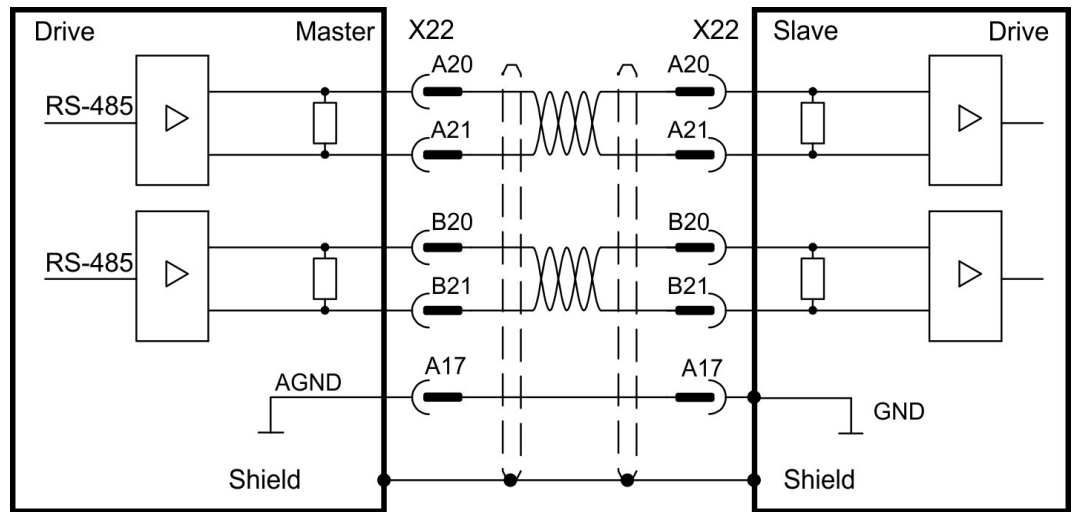

8.10.3.2 Master-Slave using optional connector X23 or X41

The master is configured for EEO1 (\rightarrow # 102) on X23 or EEO3/EEO4 (\rightarrow # 102) with SFA on X41, the Slave uses X23 (or X41 with SFA) for command input.

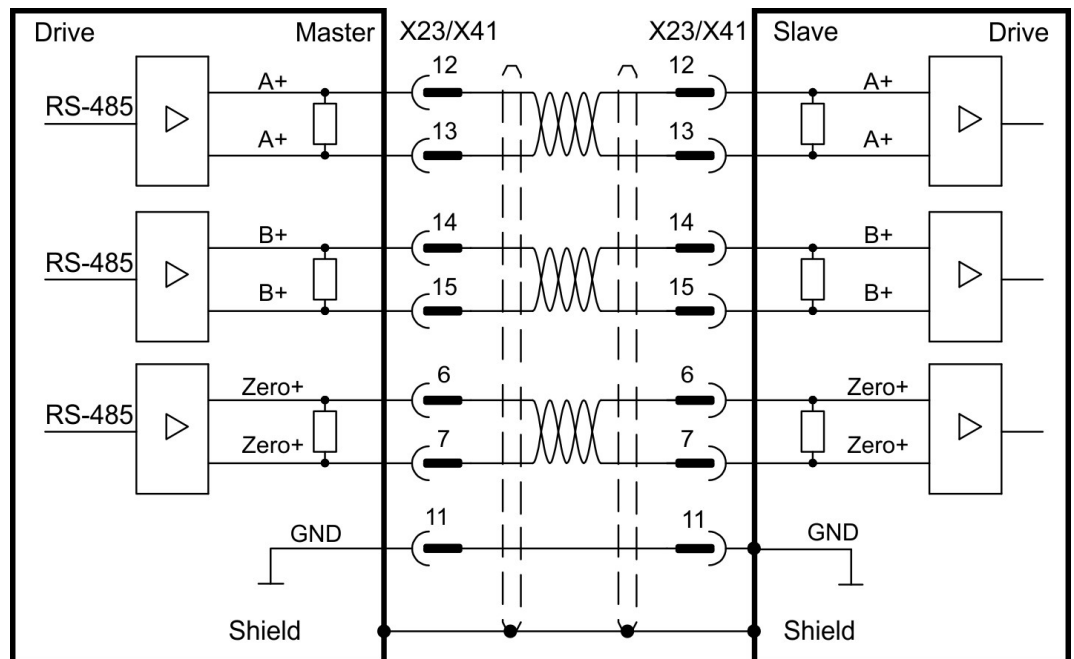

8.11 EtherNet Fieldbus Interface connector X11/X12

The EtherNet Fieldbus interface has two RJ45 connectors.

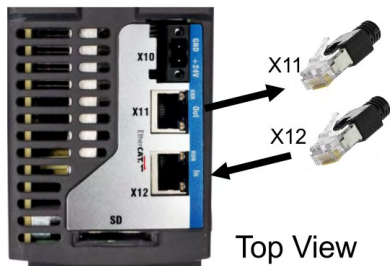

- RJ45 with built-in green/red dual-color LED.
 - EtherCAT®
 - EtherNet/IP*
 - PROFINET*
- * available 2021

NOTICE

Do not connect the Service line for the PC with the set up software to the EtherNet Fieldbus interface X11/X12. The service EtherNet cable must be connected to X20. EtherNet Fieldbus interface X11/X12 pinout depends on the used protocol. Refer to the matching fieldbus communication manual.

8.11.1 EtherCAT® and Safety over EtherCAT®

AKD2G drives (connectivity option **E**) can be connected as slaves to the EtherCAT® network (CoE) by using RJ45 connectors X11 (out port) and X12 (in port). The communication status is indicated by the built-in connector LEDs.

	Conn.	Name	Function
	X11 „Out“	„ERR“	Returns potentials communication failures: Off = No Error Blinking = Invalid configuration Single Flash = Local error Double Flash = Process data watchdog
	X11 „Out“	Link/Activity	On/Blinking: Physical link/Data Traffic on. Static off: No link.
	X12 „In“	„RUN“	Returns the device state: Off = INIT Blinking = PRE-OPERATIONAL Single Flash = SAFE-OPERATIONAL On = OPERATIONAL Flickering = Initialization or BOOTSTRAP
	X12 „In“	Link/Activity	On/Blinking: Physical link/Data Traffic on. Static off: No link.

Bus topology example (EtherCAT®)

We suggest to use Kollmorgen ENCP cables. For more possible system solutions refer to the WorkBench Online Help.

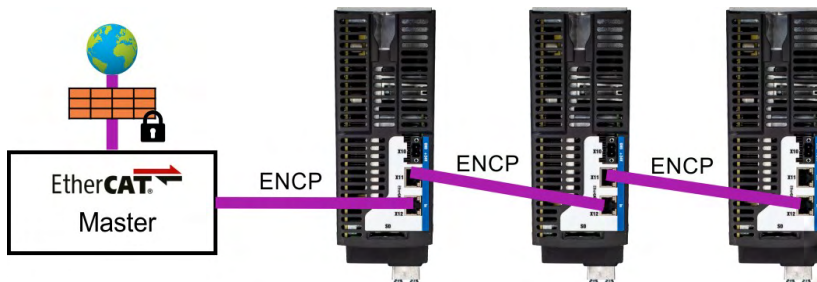

Communication profile

For EtherCAT® communication profile description refer to the manual "AKD2G EtherCAT® Communication". Notes to FSoE also see (→ # 159).

8.11.2 PROFINET (available 2021)

AKD2G with connectivity option **P** can be connected as slaves to a PROFINET network by using RJ45 connectors X11 (Port 2) and X12 (Port 1). PROFINET RT or IRT protocols can be used.



AKD2G with connectivity option **P** (PROFINET) has successfully passed the certification tests of "PROFIBUS Nutzerorganisation e.V."

Scope of the tests:

- PNIO Version: V2.35
- Conformance Class: C
- Optional Features: Legacy, MRP
- Application Class: Isochronous
- Netload Class: III

The certificate ([Z12974](#)) can be downloaded from the Kollmorgen website.

Address

The field bus address must either be set automatically or by using the memory card.

LEDs

The communication status is indicated by the built-in connector LEDs.

	Conn.	Name	Function
	X11 Port 2	BF	ON = No Configuration, low speed, no link OFF = No Error Flashing 2Hz = No data exchange
	X11 Port 2	Link/ Activity	ON = Connection to the EtherNet OFF = No connection to the EtherNet Flashing = Sends/receives EtherNet frames
	X12 Port 1	SF	ON = Watchdog timeout; channel / generic / extended diagnosis present; system error OFF = No Error Flashing 2Hz = DCP signal service is initiated via the bus
	X12 Port 1	Link/ Activity	ON = Connection to the EtherNet OFF = No connection to the EtherNet Flashing = Sends/receives EtherNet frames

Bus topology example (PROFINET)

Kollmorgen suggest to use ENCP cables. For more possible system solutions refer to the WorkBench Online Help.

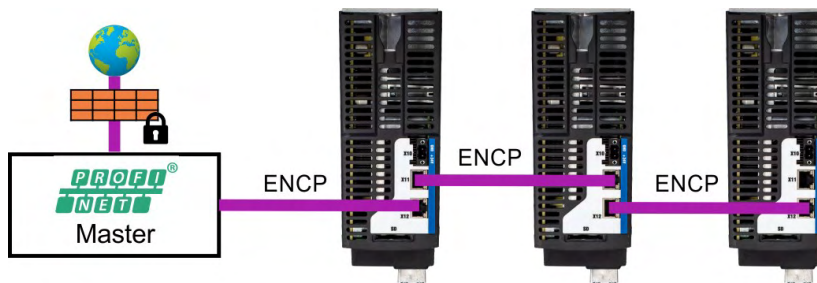

Communication profile

For PROFINET communication profile description refer to the manual "AKD2G PROFINET Communication".

8.11.3 EtherNet/IP (available 2021)

AKD2G with connectivity option I can be connected as slaves to a EtherNet/IP network by using RJ45 connectors X11 (Port 2) and X12 (Port 1). The communication status is indicated by the built-in connector LEDs.

	Conn.	Name	Function
	X11 Port 2	NS	Green - On = Connected Green - Flashing = No connections Red - On = Duplicate IP Red Flashing = Connection Timeout Red/Green Flashing = Self-test Off = No power, No IP Address
	X11 Port 2	Link/ Activity	On/Blinking: Physical link/Data Traffic on. Static off: No link.
	X12 Port 1	MS	Green - On = Device Operational Green - Flashing = Standby Red - On = Major Fault Red Flashing = Minor Fault Red/Green Flashing = Self-test Off = No power
	X12 Port 1	Link/ Activity	On/Blinking: Physical link/Data Traffic on. Static off: No link.

Bus topology example (EtherNet/IP)

We suggest to use Kollmorgen ENCP cables. For more possible system solutions refer to the WorkBench Online Help.

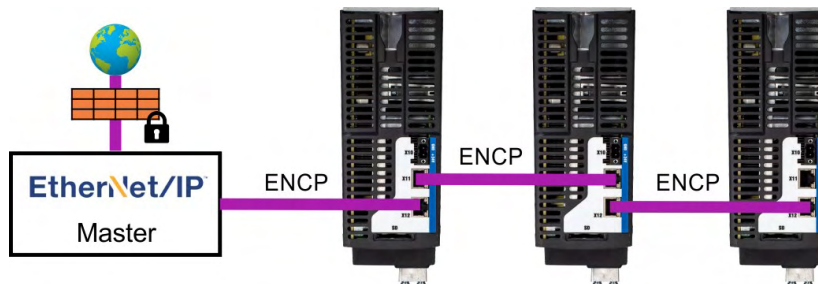

Communication profile

For EtherNet/IP communication profile description refer to the manual "AKD2G EtherNet/IP Communication".

8.12 CAN-Bus Interface connector X13/X14

AKD2G drives with connectivity option C can be connected to a CAN-Bus by using two 6-pin RJ25 connectors X13/X14.

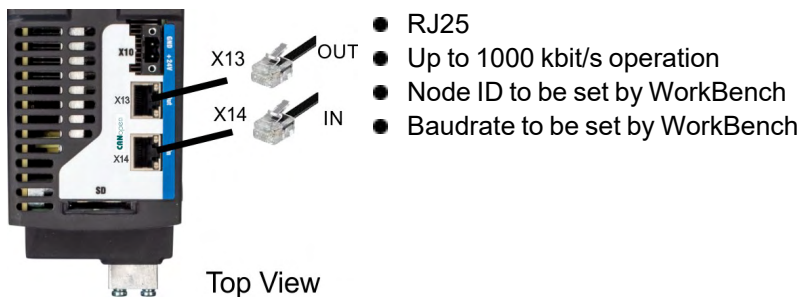

Pin	Signal	Description
1	Termination	Internal Termination Resistor
2	Shield	Chassis
3	CAN_high	CAN bus high signal
4	CAN_low	CAN bus low signal
5	CAN_GND	CAN bus ground
6	Termination	Internal Termination Resistor

8.12.1 CAN-Bus Topology

We recommend the use of Kollmorgen CBP000 cables.

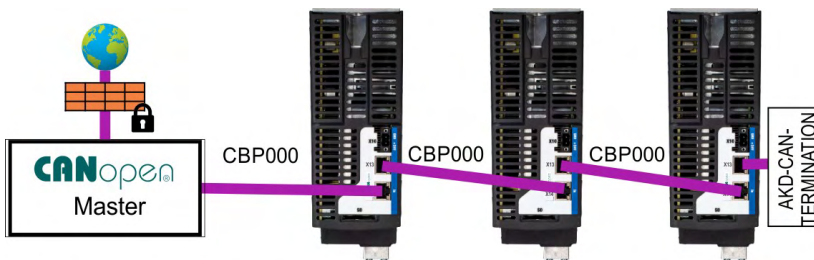

Cable requirements

To meet ISO 11898, a bus cable with a characteristic impedance of 120 Ω should be used. The maximum usable cable length for reliable communication decreases with increasing transmission speed.

As a guide, you can use the following values measured by Kollmorgen; however, these values are not assured limits:

- Characteristic impedance: 100–120 Ω
- Cable capacitance max.: 60 nF / 1000 m
- Lead loop resistance: 159.8 Ω / 1000 m

Transmission Rate (kBaud)	1000	500	250	125
Maximum Cable Length (m)	25	100	250	500

Lower cable capacitance (max. 30 nF / 1000 m) and lower lead resistance (loop resistance, 115 Ω / 1000 m) allow larger distances. The characteristic impedance 150 ± 5 Ω requires terminating resistor 150 ± 5 Ω.

Communication profile

For CANopen communication profile description refer to the manual "AKD2G CAN-Bus Communication".

8.12.2 CAN-Bus Wiring

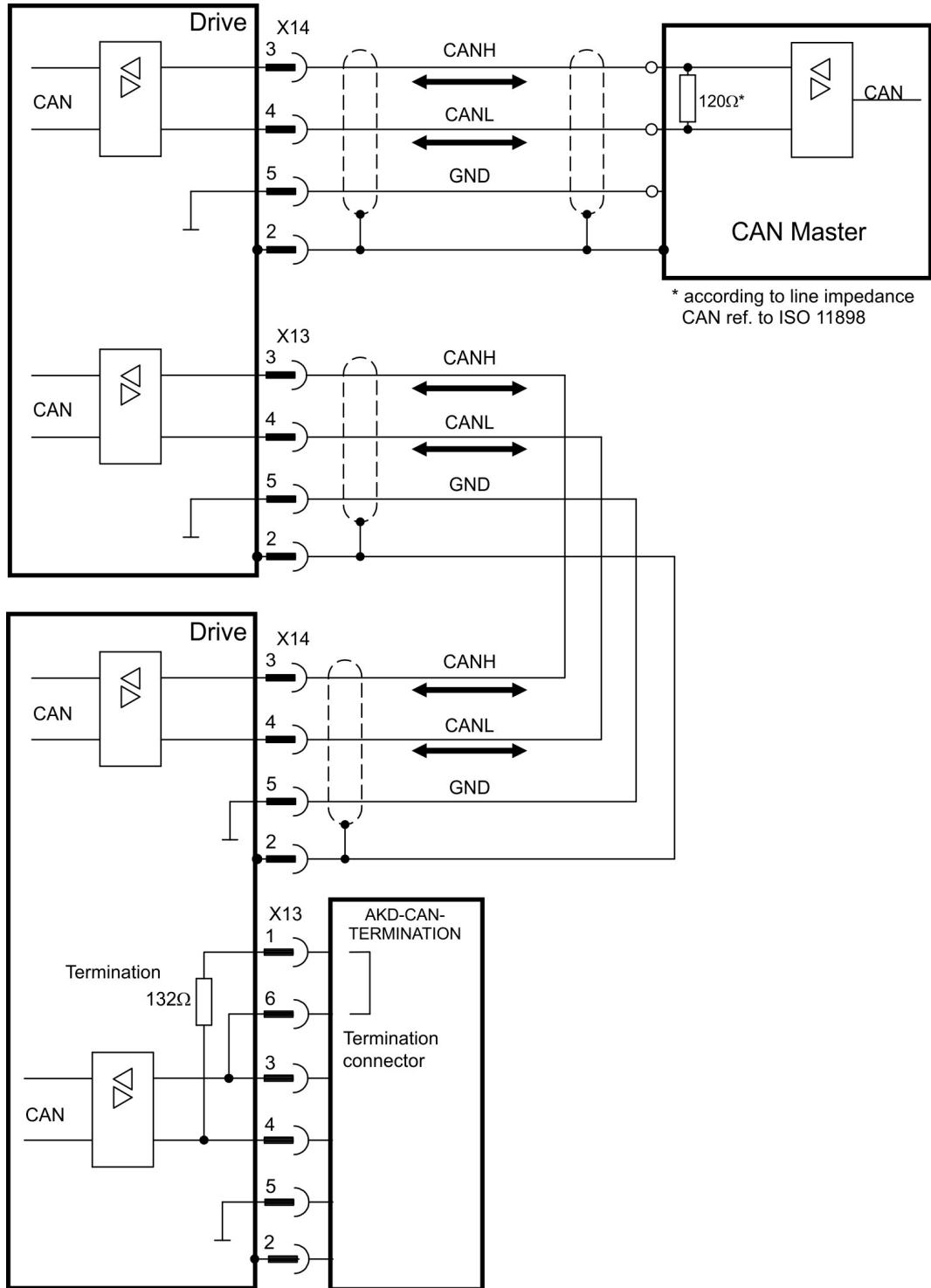

8.12.3 Baud rate for CAN-Bus

The transmission rate can be set by using the parameter **CANBUS.BAUD** in WorkBench.

Baud rate [kBit/s]	CANBUS.BAUD
125	125 (default)
250	250
500	500
1000	1000

With a fix baud rate, the drive sends the boot up message with the baud rate saved in the drive's non volatile memory after a power cycle.

8.12.4 Node Address for CAN-Bus

The node address can be set by using parameter **CANBUS.NODEID** in WorkBench.

NOTE

After changing the node address, you must turn off the 24 V auxiliary supply for the drive and then turn it on again.

8.12.5 CAN-Bus Termination

The last bus device on both ends of the CAN-Bus system must have termination resistors. The AKD2G has built-in $132\ \Omega$ resistors that can be activated by connecting pins 1 and 6. An optional termination plug is available for AKD2G (*AKD-CAN-TERMINATION*). The optional termination plug is an RJ25 connector with an enclosed wire jumper between pins 1&6. The termination plug should be inserted into the X13 connector of the last drive in the CAN network.

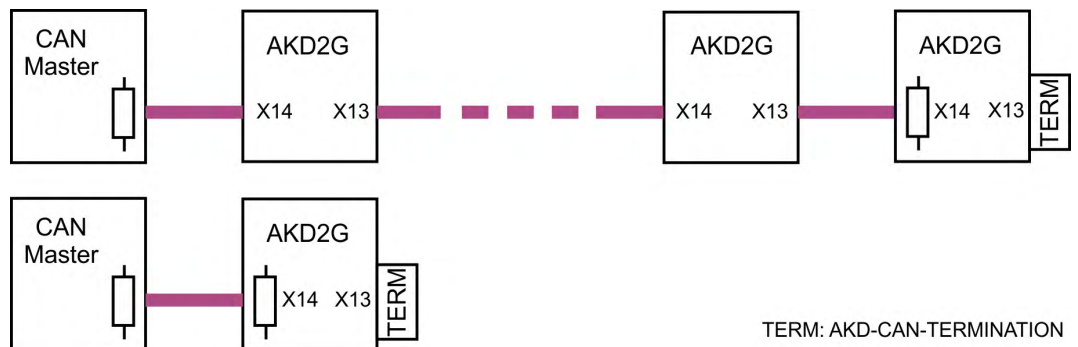

NOTE

Remove the termination connector if the AKD2G is not the last CAN-Bus device and use X13 for connecting the next CAN node.

8.13 Service Interface connector X20

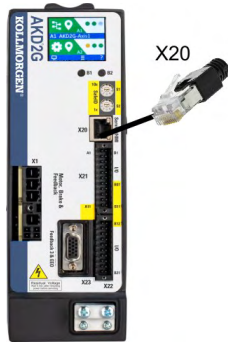

- RJ45 with built-in green/red dual-color LED
- 100/10 Mbit EtherNet TCP/IP
- Supports Auto-IP, DHCP and fixed IP addressing
- Supports point-to-point (i.e. Auto-IP) and connection by using network switches
- Supports automatic discovery in WorkBench if in the same subnet.

Pin	Signal	Description
1	Tx+	Transmit +
2	Tx-	Transmit -
3	Rx+	Receive +
4	Termination	Bob Smith termination
5	Termination	Bob Smith termination
6	Rx-	Receive -
7	Termination	Bob Smith termination
8	Termination	Bob Smith termination

Operating, position control, and motion-block parameters can be set up by using the setup software on an ordinary commercial PC (→ # 131).

Connect the service interface X20 of the drive to an EtherNet interface on the PC directly or by using a network switch, **while the supply to the equipment is switched off**. Use standard Cat. 5 EtherNet cables for connection (in some cases crossover cables will also work).

Confirm that the link LED on the AKD2G (RJ45 connector) and on your PC (or network switch) are both illuminated. If both lights are green, then you have a good electrical connection.

8.13.1 Possible Network Configurations

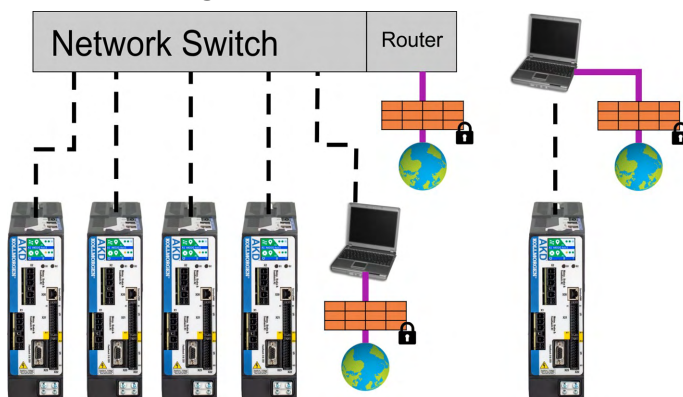

8.14 Modbus TCP connector X20

The drive can be connected to Modbus HMI by using RJ45 connector X20. The protocol allows reading and writing of drive and axis parameters.

The communication status is indicated by the built-in LED.

Connector	LED	Name	Function
X20	LED	IN port Link	green = active, red= not active

Connect the service interface (X20) of the drive to an EtherNet interface on the Modbus HMI directly or by using a network switch, **while the supply to the equipment is switched off**. Use standard Cat. 5 EtherNet cables for connection.

Confirm that the link LED on the AKD2G (the green LED on the RJ45 connector) and on your HMI or switch are both illuminated. If both LEDs are illuminated, then you have a good electrical connection.

The following are required to connect an HMI to the drive:

- The HMI must support Modbus TCP.
- It must have EtherNet hardware and a driver for Modbus TCP, though the driver does not have to be made specifically for the AKD2G family.

The subnet mask of the AKD2G is 255.255.255.0. The first three octets of the drive's IP address must be the same as the first three octets of the HMI's IP address. The last octet must be different.

Modbus TCP and WorkBench/KAS IDE can operate simultaneously if a switch is used.

Communication profile

For Modbus communication profile description refer to the WorkBench Online Help.

8.15 I/O Connectors X21/X22/X23

X21

- standard
- 2 x 11 pins, pitch 3.5 mm
- A: left connector
- B: right connector

X22

- standard
- 2 x 10 pins, pitch 3.5 mm
- A: left connector
- B: right connector

X23

- standard
- SubD 15 pins HD
- Mating connector: male

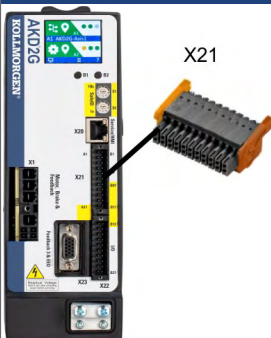
X21	Pin Signal		Pin Signal	
	Pin	Signal	Pin	Signal
	A1	Analog-In (AIN) 1 +	B1	Analog-Out (AOUT) 1
	A2	Analog-In (AIN) 1 -	B2	AGND
	A3*	Digital-In (DIN) 1	B3	+24 V
	A4*	Digital-In (DIN) 2	B4	DGND
	A5	Digital-In (DIN) 3 (HW-Enable Axis 1)	B5	Digital-Out (DOOUT) 9 + (Relay)
	A6	Digital-In (DIN) 4 (HW-Enable Axis 2)	B6	Digital-Out (DOOUT) 9 - (Relay)
	A7	Digital-In (DIN) 5	B7	SOUT1
	A8	Digital-In (DIN) 6	B8	SOUT2
	A9	Digital-In (DIN) 7	B9	SOUT3
	A10	Digital-In (DIN) 8	B10	SOUT4
	A11	SIN1	B11	SIN2

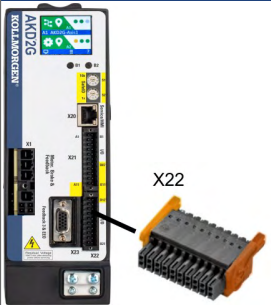
X22	Pin Signal		Pin Signal	
	Pin	Signal	Pin	Signal
	A12	SIN3	B12	SIN4
	A13	Digital-In (DIN) 9	B13	Digital-Out (DOOUT) 5
	A14	Digital-In (DIN) 10	B14	Digital-Out (DOOUT) 6
	A15	Digital-In (DIN) 11	B15	Digital-Out (DOOUT) 7 +
	A16	Digital-In (DIN) 12	B16	Digital-Out (DOOUT) 7 -
	A17	AGND	B17	Digital-Out (DOOUT) 8 +
	A18	Analog-In (AIN) 2+	B18	Digital-Out (DOOUT) 8 -
	A19	Analog-In (AIN) 2-	B19	Analog-Out (AOUT) 2
	A20*	Digital-In/Out (DIO) 1 +	B20*	Digital-In/Out (DIO) 2 +
	A21*	Digital-In/Out (DIO) 1 -	B21*	Digital-In/Out (DIO) 2 -

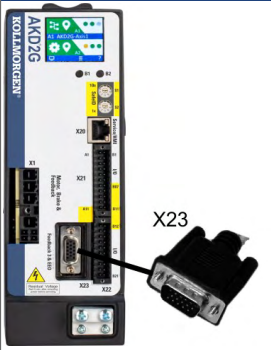
X23	Pin Signal	
	Pin	Signal
	2	Digital-In/Out (DIO) 6 +
	3	Digital-In/Out (DIO) 6 -
	6	Digital-In/Out (DIO) 5 +
	7	Digital-In/Out (DIO) 5 -
	10	+5 V
	11	0 V
	12	Digital-In/Out (DIO) 3 +
	13	Digital-In/Out (DIO) 3 -
14	Digital-In/Out (DIO) 4 +	
15	Digital-In/Out (DIO) 4 -	

8.15.1 Technical data

Interface	Electrical Data
Analog inputs Analog-In (AIN) 1 to 2	<ul style="list-style-type: none"> ● ± 10 VDC ● common mode rejection ratio: > 30 dB at 60 Hz ● resolution 16 bit and full monotonic ● update rate: 16 kHz ● non-linearity < 0.1% of full scale ● offset drift max. 250 μV/$^{\circ}$C ● input impedance > 13 kΩ
Analog outputs Analog-Out (AOUT) 1 to 2	<ul style="list-style-type: none"> ● 0 to +10 VDC, max 20 mA ● resolution 16 bit and full monotonic ● update rate: 4 kHz ● non-linearity < 0.1% of full scale ● offset drift max. 250 μV/$^{\circ}$C ● short circuit protected to AGND ● output impedance 110 Ω
Digital inputs Digital-In (DIN) 1 to 2 IEC 61131-2 Type 1	<ul style="list-style-type: none"> ● ON: 11 VDC to 30 VDC, 2 mA to 15 mA ● OFF: -5 VDC to 5 VDC, max. 15 mA ● galvanic isolation for 60 VDC ● activation / deactivation delay: < 1 μs / < 1 μs
Digital inputs Digital-In (DIN) 3 to 12 IEC 61131-2 Type 1	<ul style="list-style-type: none"> ● ON: 11 VDC to 30 VDC, 2 mA to 15 mA ● OFF: -5 VDC to 5 VDC, max. 15 mA ● galvanic isolation for 60 VDC ● delay activation / deactivation: about 5 μs / 500 μs
Digital outputs Digital-Out (DOUT) 5 to 6	<ul style="list-style-type: none"> ● max. 30 VDC, 100 mA ● short circuit proof ● galvanic isolation for 60 VDC ● delay activation / deactivation: about 5 μs / 300 μs
Digital outputs Digital-Out (DOUT) 7 to 8	<ul style="list-style-type: none"> ● volt-free contacts, max 30 VDC, 100 mA ● sink or source ● galvanic isolation for 24 VDC from PE ● delay activation / deactivation: about 5 μs / 50 μs
Digital inputs/outputs Digital-In/Out (DIO) 1 to 6	<ul style="list-style-type: none"> ● RS485, 5V, max 100mA ● reference potential X22: AGND, X23: 0V ● input OFF: -0.3 V to +0.3 V ● selectable termination, difference/single ended ● delay activation / deactivation: about 50 ns
Digital output Digital-Out (DOUT) 9	<ul style="list-style-type: none"> ● max. 30 VDC, 1A ● max. 42 VAC, 1 A ● galvanic isolation for 24 VDC from PE ● delay open/close: 10 ms / 10 ms
Safe digital inputs SIN1 to SIN4	<ul style="list-style-type: none"> ● ON: > 15 VDC, > 2 mA, OFF: < 5 VDC, < 1 mA ● galvanic isolation for 60 VDC ● delay activation / deactivation about: 1.5 ms / 3.5 ms ● test pulse are required
Safe digital outputs SOUT1 to SOUT4	<ul style="list-style-type: none"> ● volt-free contacts, max 30 VDC, 172 mA ● short circuit proof ● galvanic isolation for 24 VDC from PE ● activation delay (0->1) depends on the safety function ● hardware deactivation delay (1>0) about 300 μs ● emits test pulses

8.15.2 Analog Input

The drive is fitted with differential inputs for analog torque, velocity, or position control. The standard drive offers one analog input on X21, dual axis drives and drives with built-in option IO or DX offer a second analog input on X22.

NOTICE

Maximum distance for unshielded I/O lines is 3 m inside the cabinet. If the I/O cable leaves the cabinet, it must be EMC shielded.

Technical characteristics

- Differential input voltage range: ± 10 V
- Maximum input voltage referring to I/O Return: -12.5, +16.0 V
- Resolution: 16 Bit and fully monotonic
- Firmware update rate: 16 kHz
- Unadjusted offset: < 50 mV
- Offset drift typ: $250 \mu\text{V} / ^\circ\text{C}$
- Gain or slope tolerance: $\pm 3\%$
- Nonlinearity: < 0.1% of full scale or 12.5 mV
- Common Mode Rejection Ratio: > 30 dB at 60 Hz
- Input impedance: > 13k Ω s
- Signal to noise ratio referred to full scale:
 - AIN.CUTOFF = 3000 Hz: 14 bit
 - AIN.CUTOFF = 800 Hz: 16 bit

Analog Input Wiring Diagram

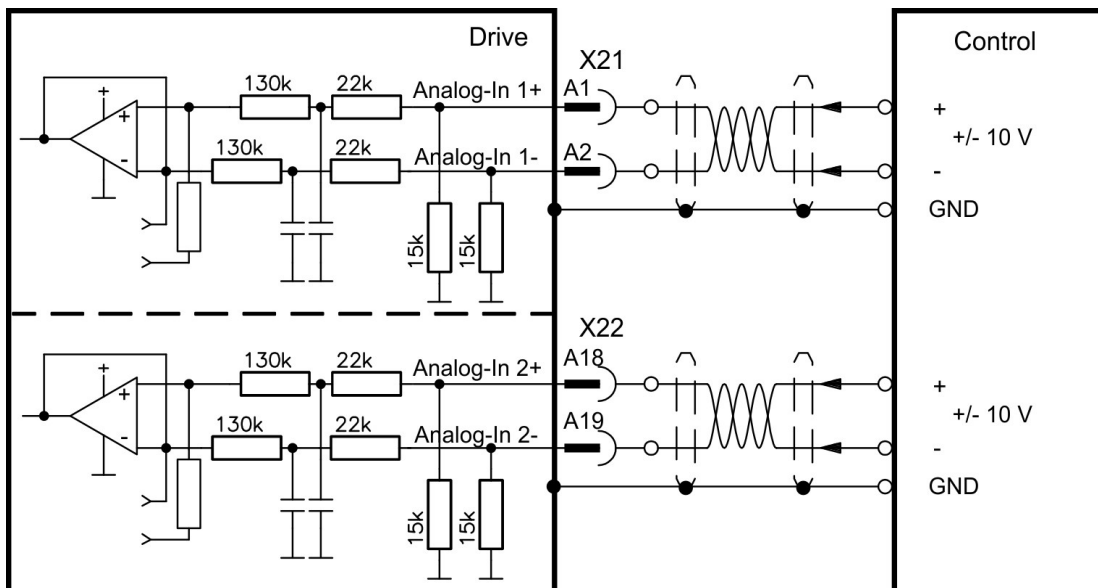

Application examples for set point input Analog-In:

- reduced-sensitivity input for setting-up/jog operation
- pre-control/override

Defining the direction of rotation

Standard setting: clockwise rotation of the motor shaft (looking at the shaft end) affected by positive voltage between terminal (+) and terminal (-)

To reverse the direction of rotation, swap the connections to terminals +/- or change parameter AXIS#.DIR in WorkBench.

8.15.3 Analog Output

Analog Outputs can be used to output converted analog values of digital measurements recorded in the drive. The standard drive offers one analog output on X21, dual axis drives and drives with built-in option IO or DX offer a second analog output on X22.

NOTICE

Maximum distance for unshielded I/O lines is 3 m inside the cabinet. If the I/O cable leaves the cabinet, it must be EMC shielded.

Technical characteristics

- Output voltage range referring to AGND: 0 to 10 V
- Resolution: 16 Bit and fully monotonic
- Update rate: 4 kHz
- Unadjusted offset: < 50 mV
- Offset drift typ: 250 $\mu\text{V}/^\circ\text{C}$
- Gain or slope tolerance: +/- 3%
- Nonlinearity: < 0.1% of full scale or 20 mV
- Output impedance: 110 Ω
- Specification complies with IEC 61131-2 Table 11
- -3 dB Bandwidth: >8 kHz
- Maximum output current: 20 mA
- Capacitive load: any value but response speed limited by max lout and by Rout
- Protected for short circuit to AGND

Analog Output Wiring Diagram

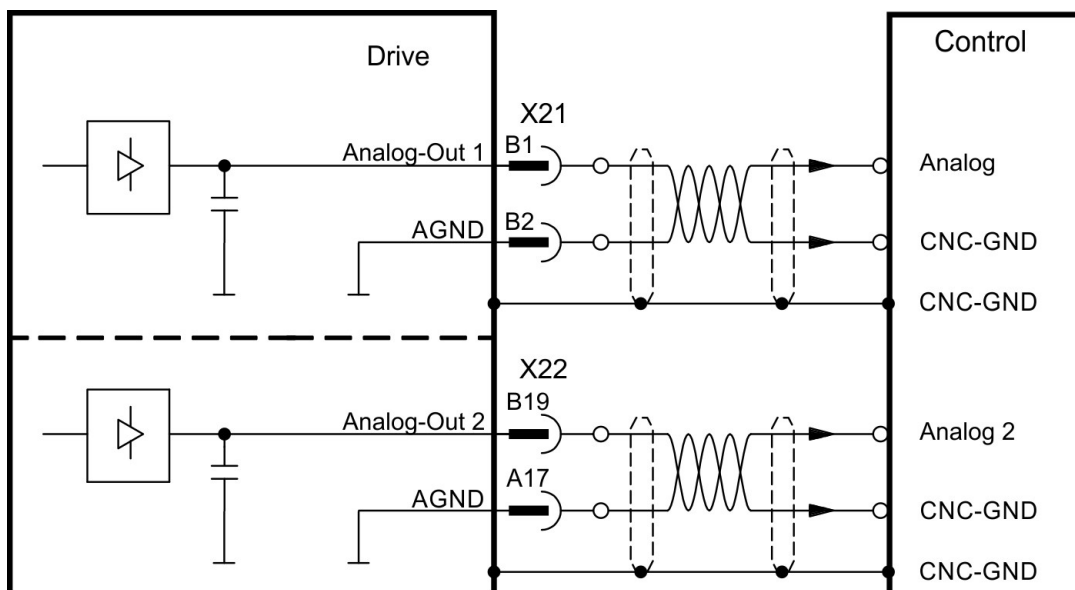

8.15.4 Digital Inputs

The drive provides 8 digital inputs on X21. Dual axis drives and drives with built-in option IO or DX offer additional 4 inputs on X22 and 2 programmable Input/Outputs on X22. If X23 is built-in and not used for feedback or EEO function, then it offers 4 additional programmable Input/Outputs.

All inputs can be used to initiate pre-programmed actions. A list of actions is included in the WorkBench. If an input is programmed, it must be saved to the drive.

The drive provides 4 safe digital inputs on X21 and X22. These inputs can be used as safe inputs, based on the installed functional option (→ # 156).

NOTICE

Maximum distance for unshielded I/O lines is 3 m inside the cabinet. If the I/O cable leaves the cabinet, it must be EMC shielded.

NOTE

Depending on the selected function, the inputs are high or low active. Digital input filter can be set in WorkBench to change sensitivity of the inputs (see Online Help).

8.15.4.1 Digital-In 1 and 2

These inputs (IEC 61131-2 Type 1) are particularly fast and are therefore suitable for position latch functions. They can also be used as 24 V inputs for electronic gearing (→ # 101).

Technical characteristics

- Floating, reference common line is DGND
- High: 11 to 30 V/2 to 15 mA , Low: -5 to +5 V/<15 mA
- Update rate: firmware reads hardware input state every 250 μ s
- High accuracy latch: motor feedback position or interpolated time is latched or captured within 2 μ s of input signal transition (with digital input filter set to 40 ns)
- The AKD2G capture engine is polled every 62.5 μ s (16 kHz) by the firmware

Wiring example

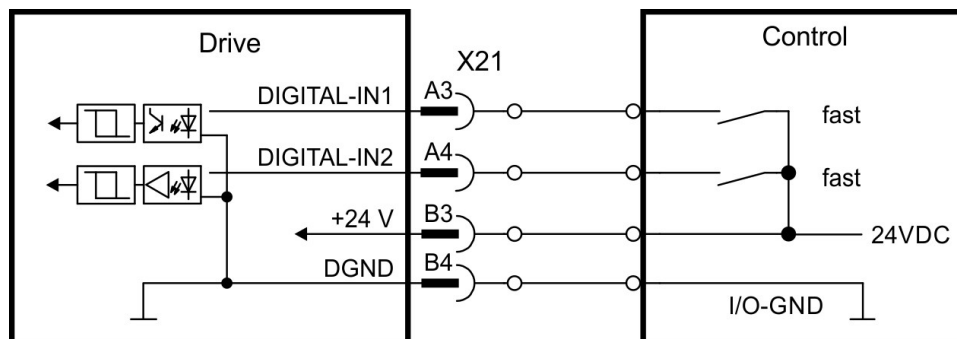

8.15.4.2 Digital-In 3 to 12

These inputs (IEC 61131-2 Type 1) are programmable with the setup software.

Manufacturer setting:

- Digital-In 3: HW-Enable Axis 1
- Digital-In 4: HW-Enable Axis 2
- Digital-In 5 ...12: off

Choose the function you require in WorkBench. For more information refer to WorkBench.

Technical characteristics

- Floating, reference common line is DGND
- High: 11 to 30 V/2 to 15 mA , Low: -5 to +5 V/<15 mA
- Update rate: firmware reads hardware input state every 250 μ s

Wiring example

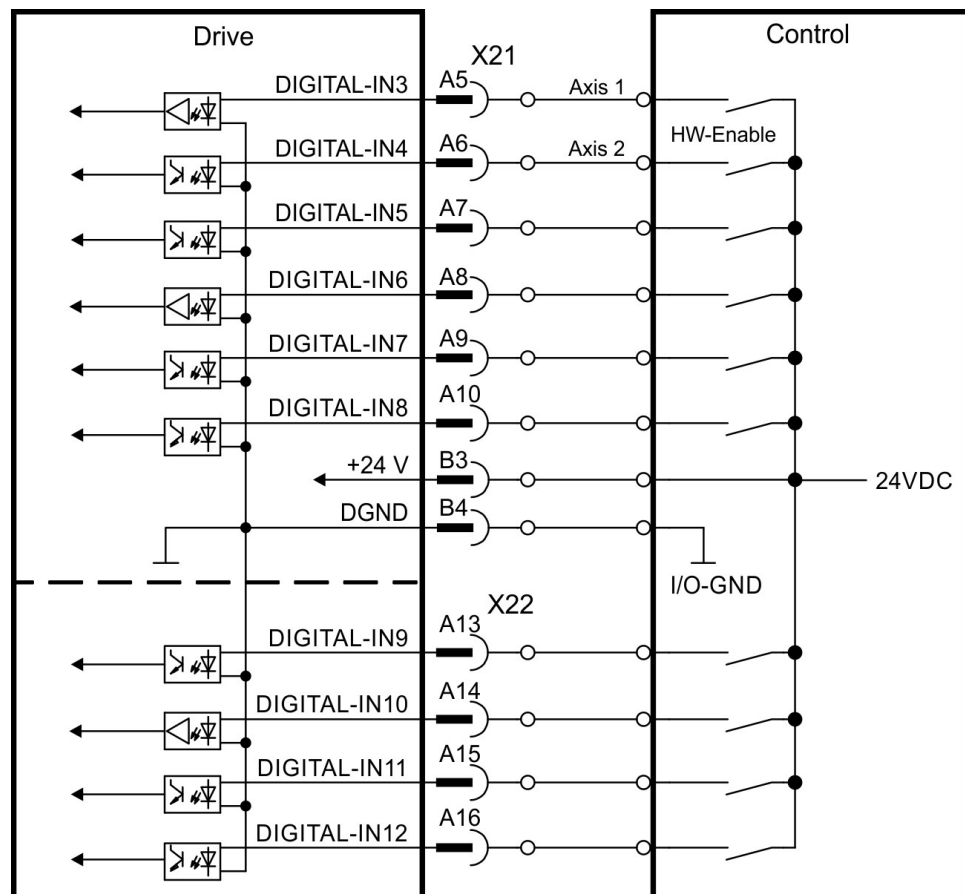

8.15.4.3 Digital-In/Out 1 and 2

Pins X22/A20-A21 (Digital-In/Out 1) and X22/B20-B21 (Digital-In/Out 2) can be defined as either inputs or outputs. For programming refer to WorkBench.

NOTICE

NOT compatible with 24V signal level! Will be damaged if connected to +24V!

Technical characteristics if configured as input

- RS485, reference common line is AGND
- No wire break detection
- Digital IN/OUT 1/2: Selectable DC termination for differential or single ended input
- Update rate: firmware reads hardware input state every 250 μ s

Wiring example

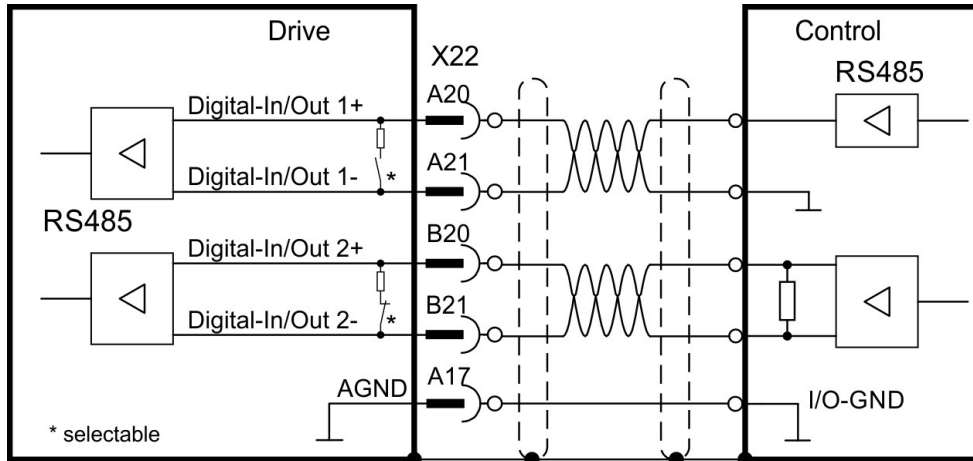

8.15.4.4 Digital-In/Out 3 to 6

X23 can be used for digital I/O. The channels can be defined as inputs or outputs. For programming refer to WorkBench.

NOTICE

NOT compatible with 24V signal level! Will be damaged if connected to +24V!

Technical characteristics if configured as input

- RS485, reference common line is 0V
- No wire break detection
- Digital IN/OUT 3/4: Selectable DC termination for differential or single ended input
- Digital IN/OUT 5/6: AC termination for single ended input
- Update rate: firmware reads hardware input state every 250 μ s

Wiring example

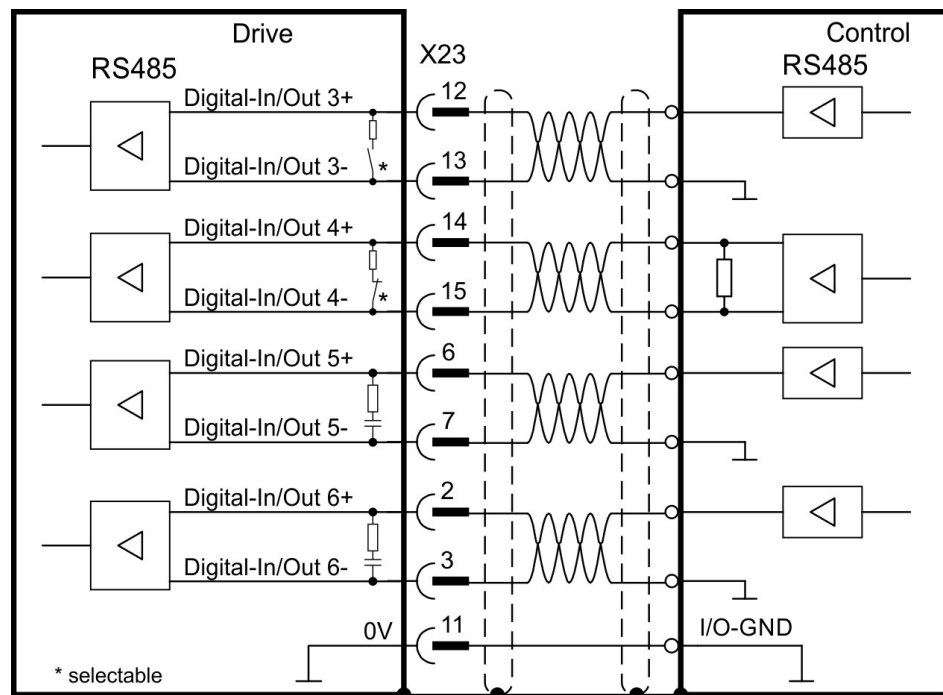

8.15.5 Digital Outputs

The drive provides 4 safe digital outputs on X21. These outputs can be used as safe outputs see (→ # 157). For more information refer to the setup software.

Dual axis drives and drives with built-in option IO or DX offer additional 4 digital outputs and 2 programmable Input/Outputs. If X23 is built-in and not used for feedback or EEO function, then it offers 4 additional programmable Input/Outputs.

The relay output can be used as fault or ready to operate signal.

NOTICE Maximum distance for unshielded I/O lines is 3 m inside the cabinet. If the I/O cable leaves the cabinet, it must be EMC shielded.

Choose the required action in the setup software. Messages from pre-programmed actions. A list of actions is included in the WorkBench. If an output is programmed, it must be saved to the drive.

8.15.5.1 Digital-Out 5 to 6

These outputs are programmable with the setup software. By default, all outputs are off.

Technical characteristics

- The outputs can switch +5 V to +30 V
- All digital outputs are floating
- High side, output current max. 100 mA
- Update rate: 250 μ s

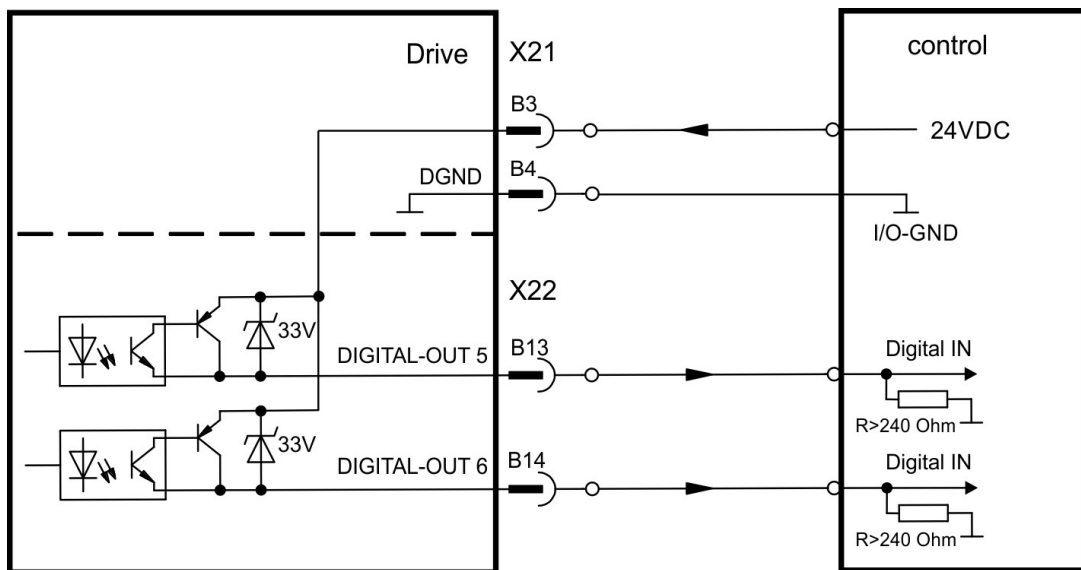

8.15.5.2 Digital-Out 7 and 8

These outputs are programmable with WorkBench. By default, all outputs are not programmed (off).

Technical characteristics

- The outputs can switch +5 V to +30 V
- Galvanic isolation for 24 VDC from PE
- The two channels are isolated from one another and not referred to a common potential
- Output current max. 100 mA
- Can be wired as sinking or sourcing (see examples below)
- Update rate: 250 μ s

Wiring examples

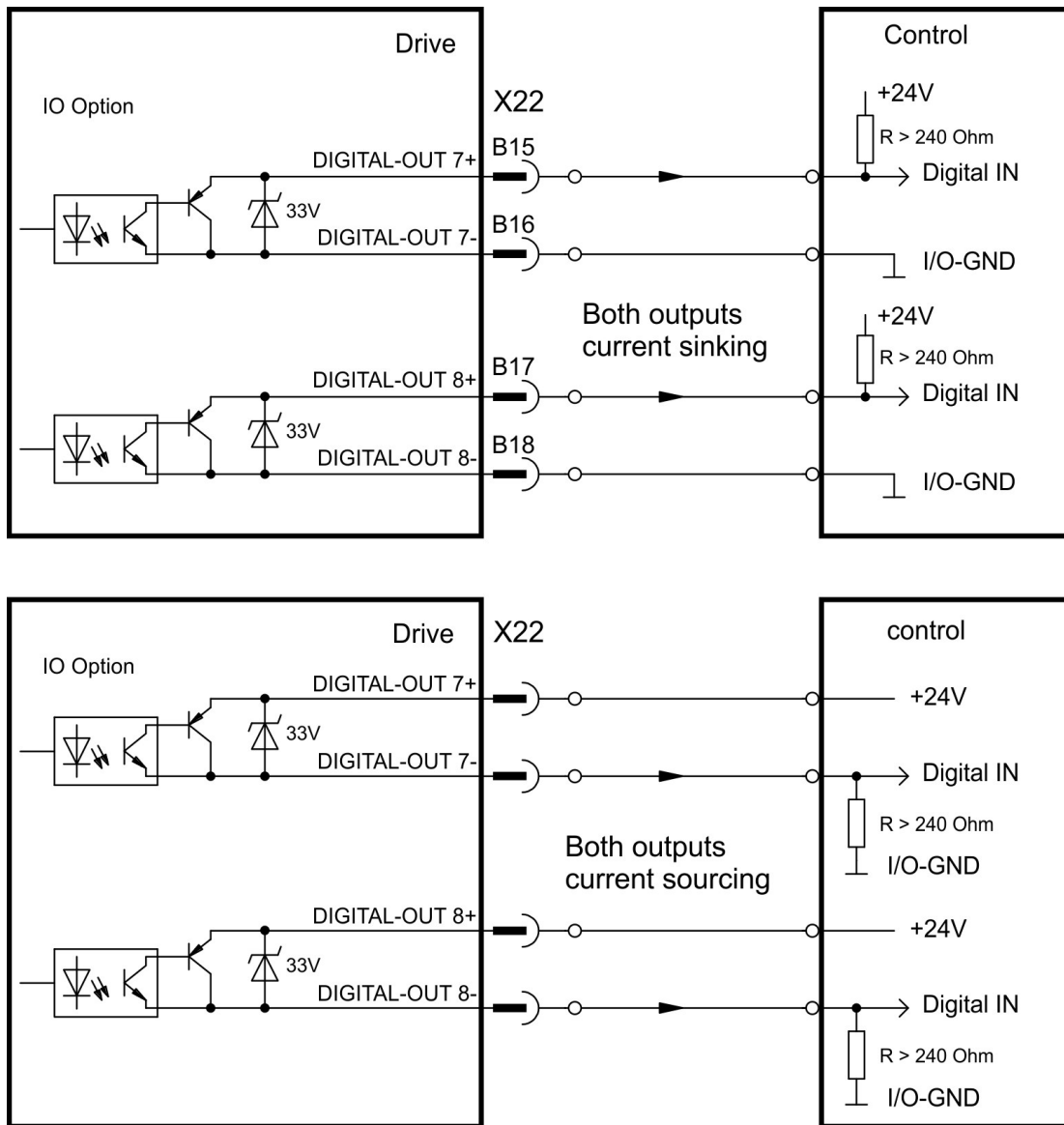

8.15.5.3 Digital-In/Out 1 and 2

Pins X22/A20-A21 (Digital-In/Out 1) and X22/B20-B21 (Digital-In/Out 2) can be used as either inputs or outputs. For programming refer to WorkBench.

Technical characteristics if configured as output

- RS485, reference common line is AGND
- Selectable DC termination for differential or single ended output, no wire break detection
- Update rate: 250 μ s

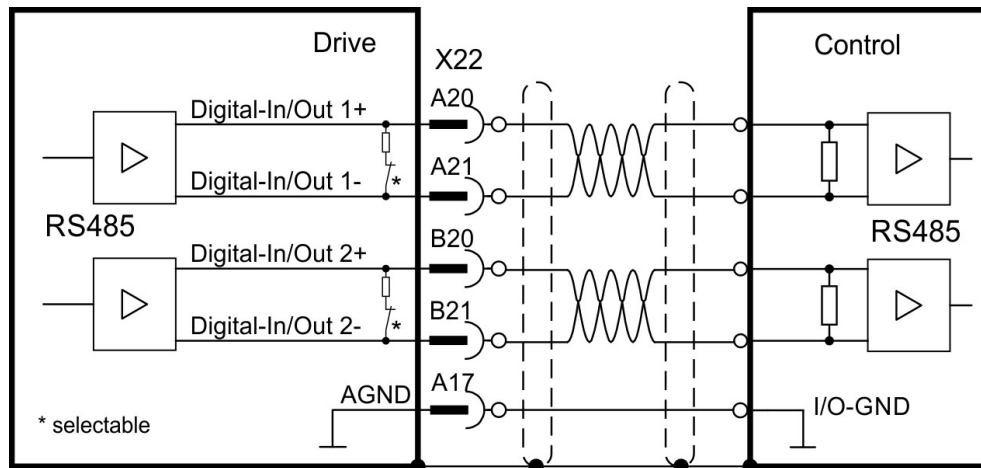

8.15.5.4 Digital-In/Out 3 to 6

X23 can be used for digital I/O. The channels can be defined as inputs or outputs. For programming refer to WorkBench.

Technical characteristics if configured as output

- RS485, reference common line is 0V
- No wire break detection
- Digital IN/OUT 3/4: Selectable DC termination for differential or single ended output
- Digital IN/OUT 5/6: AC termination for single ended output
- Update rate: 250 μ s

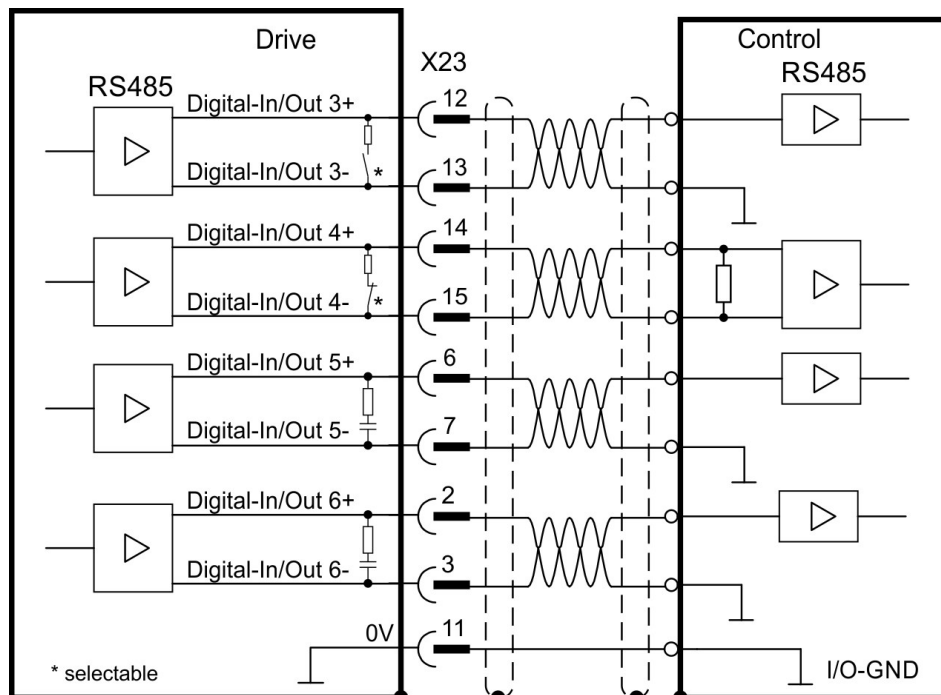

8.15.5.5 Digital-Out 9, Relay contacts

Digital-Out 9 is programmable with the setup software (for more information refer to WorkBench).

By default, the output function is defined as ready to operate output by action parameter.

NOTICE

If an inductive load (relay or similar) is used, a freewheeling diode must be added to the load.

Technical characteristics

- Relay output, max. 30 VDC or 42 VAC, 1 A
- Galvanic isolation for 24 VDC from PE
- Time to close: max. 10 ms
- Time to open: max. 10 ms

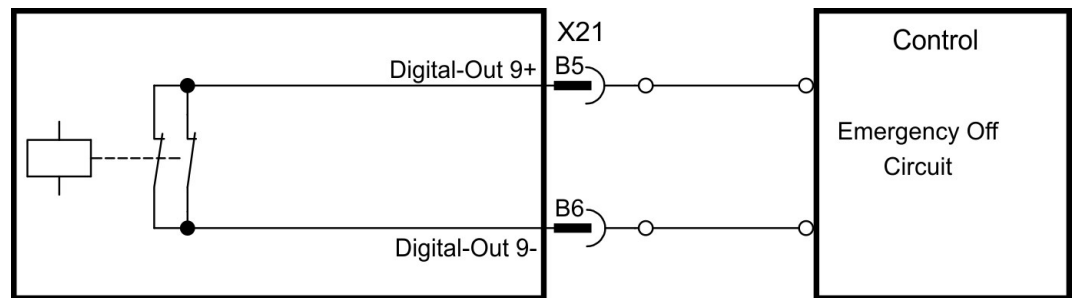

9 Setup

9.1 Important Notes	125
9.2 Guide to drive setup	126
9.3 Switch-On and Switch-Off Behavior	133
9.4 Fault and Warning Messages	140
9.5 Troubleshooting	141

9.1 Important Notes

NOTICE

Only professional personnel with extensive knowledge in the fields of electrical engineering and drive technology are allowed to test and set up the drive.



⚠ DANGER Lethal Voltage!

There is a danger of serious personal injury or death by electrical shock. Lethal danger exists at live parts of the device.

- Built-in protection measures such as insulation or shielding may not be removed.
- Work on the electrical installation may only be performed by trained and qualified personnel, in compliance with the regulations for safety at work, and only with switched off mains supply, and secured against restart.
- In normal operation, the cabinet door must be closed and the device must not be touched.



⚠ WARNING Automatic Restart!

Risk of death or serious injury for humans working in the machine. The drive might restart automatically after power on, voltage dip or interruption of the supply voltage, depending on the parameter setting. If parameter AXIS#.ENDEFAULT is set to 1,

- then place a warning sign ("WARNING: Possible Automatic Restart" or similar) to the machine.
- Ensure, that power on is not possible, while humans are in a dangerous zone of the machine.



⚠ CAUTION High Temperature!

Risk of minor burns. The heat sink of the drive can reach temperatures up to 80°C in operation.

- Check the heat sink temperature before handling the drive.
- Wait until the heat sink has cooled down to 40°C before touching it.

NOTICE

If the drive has been stored for more than 1 year, you must re-form the capacitors in the DC bus link circuit. Re-forming procedures are described in the KDN ([Forming](#)).

NOTE

Additional information on setting up the equipment:

- Programming parameters and control loop behavior are described in the AKD2G User Manual (Online Help).
- The setup of any fieldbus is described in the corresponding manual on the DVD.

9.2 Guide to drive setup

NOTICE

Setup must be done in two major steps:

1. Drive setup (this section). This section presents an example to test the drive initially. If the drive (motor, feedback, control circuits, I/Os) is well parameterized, then proceed with the
2. Functional Safety setup (→ # 147).

9.2.1 Initial Drive Test Procedure

9.2.1.1 Unpacking, mounting, and wiring the AKD2G

1. Unpack the drive and accessories.
2. Mount the drive.
3. Wire the drive or apply the minimum wiring for drive testing as described below.
4. Make sure you have on hand the following information about the drive components:
 - rated mains supply voltage
 - motor type (motor data, if the motor type is not listed in the motor database)
 - feedback unit built into the motor (type, poles/lines/protocol)
 - moment of inertia of the load

9.2.1.2 Minimum wiring for drive test without load, example

NOTICE

This wiring diagram based on default settings is for general illustration only and does not fulfill any requirements for EMC, functional safety, or functionality of your application.

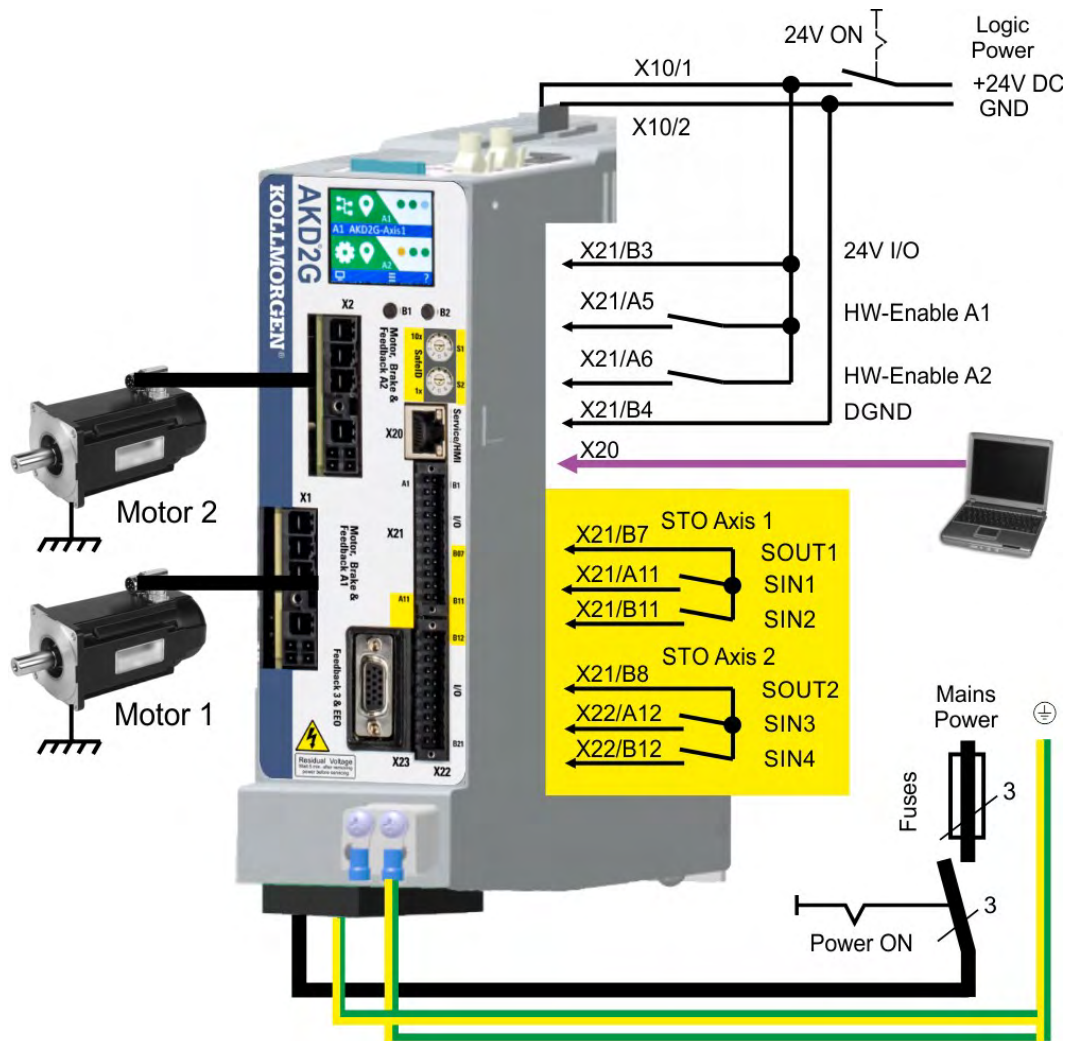

9.2.1.3 Confirm connections (example: directly to PC)

You can turn on logic power to the drive through the X10 connector (mains power voltage is not needed for communications).

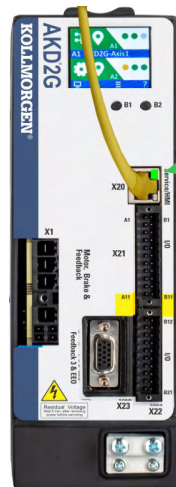

Confirm that the link LEDs on the drive (green LED on the RJ45 connector) and on your PC are both illuminated. If both LEDs are illuminated, then you have a working electrical connection.

The LCD display shows a sign, if the connection between AKD2G and WorkBench is active.

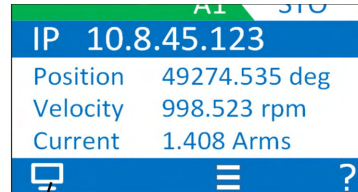

Service Port
Connected

Use WorkBench to configure the drive by using the service interface.

9.2.1.4 System integration

MAC Address

The unique MAC address is pre-defined by the manufacturer (see nameplate).

Service IP Address

The AKD2G service port X20 supports auto-IP, DHCP and static IP addressing.

The drive is delivered with IP address 0.0.0.0. Depending on the connection (switch or PC) either DHCP or auto-IP mechanism assigns a unique IP address.

WorkBench uses the IP address to detect AKD2G devices in the LAN and start communication. With WorkBench you can set a static IP address for the drive (parameter *IP.ADDRESS*).

EtherCAT Node Address

The EtherCAT node address is assigned automatically by the EtherCAT master.

CAN Node ID

Set a CAN node ID for the drive in WorkBench (parameter *CANBUS.NODEID*).

PROFINET

The station name and IP address must be set manually through the PROFINET master.

SafeID

Every module must have a unique SafeID in the safety system. Set the SafeID for every module with the two decimal rotary switches in the front.

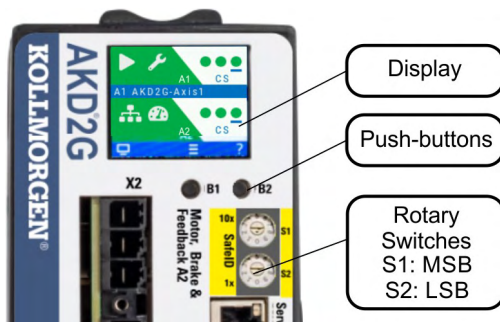

Process to set the SafeID

1. Switch off 24V supply voltage.
2. Set S1 and S2 to a unique SafeID.
3. Switch on the 24V supply voltage.

The SafeID is calculated based on the rotary switches setting:

$$\text{SafeID} = 10 \cdot S1 + S2$$

Example

Rotary switches: S1 = 2, S2 = 3 → SafeID = 10 • 2 + 3 = 23

Factory default setting

Rotary Switch setting S1 = 0, S2 = 1. Resulting SafeID is 1.

FSoE Address

The unique FSoE address for every axis is derived from the set SafeID.

FSoE address for axis 1 = SafeID • 100 + 1

FSoE address for axis 2 = SafeID • 100 + 2

Example

Rotary switches setting: S1 = 2, S2 = 3 → SafeID = 10 • 2 + 3 = 23

Resulting FSoE address for axis 1 = 23 • 100 + 1 = 2301

Resulting FSoE address for axis 2 = 23 • 100 + 2 = 2302

Factory default setting

Rotary Switch setting S1 = 0, S2 = 1. Resulting SafeID is 1.

Resulting FSoE address for axis 1 = 1 • 100 + 1 = 101

Resulting FSoE address for axis 2 = 1 • 100 + 2 = 102

9.2.1.5 Install and start WorkBench

WorkBench is available from the DVD included with the drive. WorkBench is also available on the Kollmorgen Website: www.kollmorgen.com. Select the install file and follow the instructions given by the installer.

Once installation is complete, click the WorkBench icon to start the program.

9.2.1.6 Setup the axis in WorkBench

Use the setup wizard and

1. Connect the axis,
2. Setup the axis and
3. Save parameter set to the drive.

Refer to the WorkBench Online Help for details.

9.2.1.7 Enable the axis (Hardware)

1. Switch 24 V to the STO inputs (X21/A11-B11 for axis 1 or X21/A12-B12 for axis 2)
2. Switch 24 V to the digital inputs for Hardware Enable Axis 1 (X21/A5) or 2 (X21/A6).

9.2.1.8 Move the motor axis

1. Select the axis in WorkBench
2. Enter Service Motion view
3. select "Reversing", check the default velocity and time settings for plausibility
4. Click on Start.

9.2.1.9 Tune the axis

Details see *WorkBench Online Help*

9.2.2 WorkBench Installation

This chapter describes the installation of the WorkBench software for AKD2G drives. Kollmorgen offers training and familiarization courses on request.

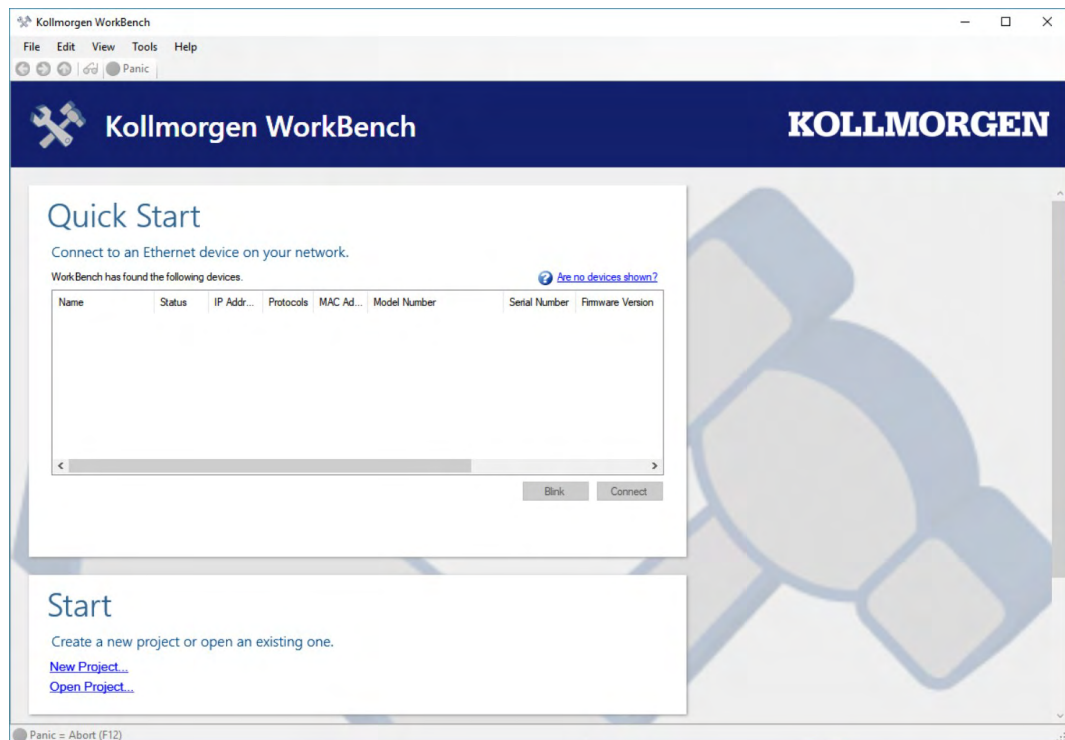

9.2.2.1 Use as directed

The setup software is intended to be used for altering and saving the operating parameters for the AKD2G series of drives. The attached drive can be set up with the help of this software, and during this procedure the drive can be controlled directly by the service functions.

Only professional personnel who have the relevant expertise (→ # 16) are permitted to carry out online parameter setting for a drive that is running.

Sets of data that have been stored on data media are not safe against unintended alteration by other persons. Unexpected move could be the result if you use unchecked data. After loading a set of data you must therefore validate parameters which are relevant for the application before enabling the drive.

9.2.2.2 Software description

Each drive must be configured to the requirements of your machine. For most applications, you can use a PC and WorkBench (the drive setup software) to set up the operating conditions and parameters for your drive.

The PC is connected to the drive by an EtherNet cable (→ # 110). The setup software provides the communication between the PC and AKD2G. You can find the setup software on the accompanying DVD and in the download area of the Kollmorgen website.

You can alter parameters easily and instantly observe the effect on the drive, since there is a continuous (online) connection to the drive. You can also read important actual values from the drive, which are displayed on the monitor of the PC (oscilloscope functions).

You can save sets of data on data media (archiving) and load them into other drives or use them for backup. You can also print out the data sets.

Most standard feedback systems are plug and play compatible. Motor nameplate data is stored in the feedback device and read by the drive automatically at startup. Non-plug and play Kollmorgen motors are stored in WorkBench and can be loaded with one-click using the Motor screen in the WorkBench software.

An extensive online help with integrated description of all variables and functions supports you in each situation.

9.2.2.3 Hardware requirements

The Service interface (X20, RJ45) of the drive is connected to the EtherNet interface of the PC by an EtherNet cable (→ # 110).

Minimum requirements for the PC:

Processor: at least 1 GHz

RAM: 512 MB

Graphics adapter: Windows compatible, color, minimum 1024 x 768 dpi

Drives: hard disk with at least 500 MB free space, DVD drive or download from internet

Interface: one free EtherNet Interface, or Switch port

9.2.2.4 Operating systems

Windows 7/8/10

WorkBench works with Windows 7, 8 and 10.

DotNet framework 4.8 or higher is required.

Internet Explorer 10 or higher.

Unix, Linux

The software does not run on Unix/Linux.

9.2.2.5 Installation under Windows 7/8/10

The DVD includes an installation program for the setup software. The latest setup software can be downloaded from www.kollmorgen.com.

Installation

- Autostart function activated:
Insert the DVD into a free drive. A window with the start screen opens. There you find a link to the WorkBench setup software. Click it and follow the instructions.
- Autostart function deactivated:
Insert the DVD into a free drive. Click **Start** (task bar), then **Run**. Enter the program call: x:\index.htm (x = correct DVD drive letter).
Click **OK** and proceed as described above.

Connection to the EtherNet interface of the PC

- Connect the interface cable to an EtherNet interface on your PC or to a Switch and to the AKD2G service interface X20 (→ # 110).

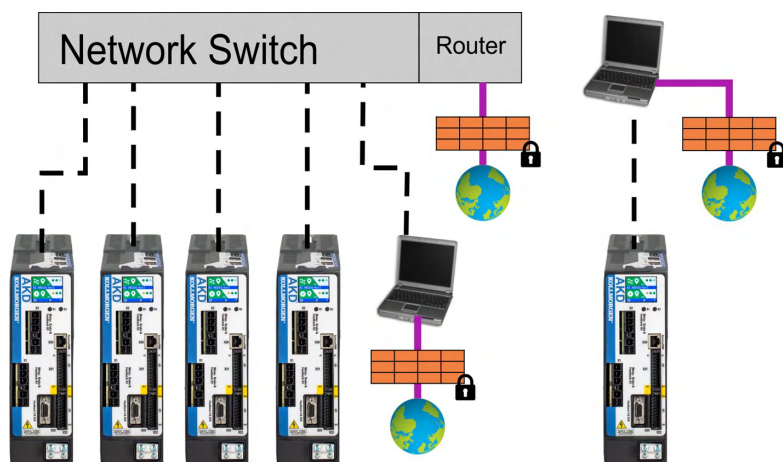

The LCD display shows a sign, if the connection between AKD2G and WorkBench is active.

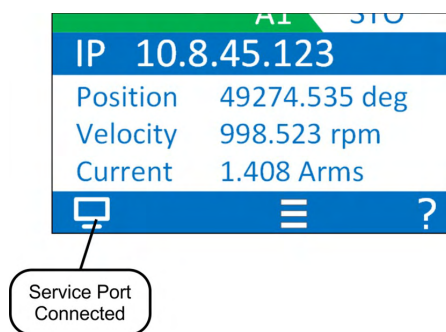

9.3 Switch-On and Switch-Off Behavior

This chapter describes the switch-on and switch-off behavior of the AKD2G with STO.

Behavior of “holding brake” function

Drives with an enabled holding brake function have a special timing for switching on and off the output stage (→ # 91). Events that remove the AXIS#.ACTIVE signal trigger the holding brake to apply. As with all electronic circuits, the general rule applies that there is a possibility of the internal holding brake module failing.

If the drive detects the motor to be at zero velocity (as configured by AXIS#.ZEROT and AXIS#.ZEROV) or timeout occurs during a stop procedure, the brake is applied. Set parameter AXIS#.MOTOR.BRAKEIMM to 1 with vertical axes, to apply the motor holding brake (→ # 91) immediately after faults or Hardware Disable.

Behavior when undervoltage condition is present

The behavior in an undervoltage condition depends on the VBUS.UVMODE setting.

VBUS.UVMODE	DC Bus Undervoltage Mode. Consult the WorkBench Online Help for configuring the parameter.
0	The drive will report a F2007 undervoltage fault any time an undervoltage condition occurs.
1 (default)	The drive will report a warning W2007 if not enabled. The drive will report a fault if the drive is enabled when the condition occurs, or an attempt is made to enable while an under voltage condition occurs.

Functional Safety

The drive can be braked down using SS1 and SDB and secured to standstill with SBC and STO. Even when power is being supplied, the drive shaft is protected against unintentional restart. The chapter “Functional Safety” describes how to use the safety functions (→ # 143).

- Functional Safety can be ensured with configured SBC (→ # 171) only.
- For SIL 3 a second (external) motor brake for an axis is required. For single axis drives this brake can be connected to X4 (→ # 93). For dual axis drives the additional brake must be controlled from another source (e.g. from the other axis or externally from a safety controller). The brakes can be mapped to an axis with WorkBench.
- The Hardware Enable does not initiate a controlled stop but switches off the power stage immediately.
- Set parameter AXIS#.MOTOR.BRAKEIMM to 1 with vertical axes, to apply the brake immediately after faults or Hardware Disable.

9.3.1 Switch-on behavior in standard operation

The diagram below illustrates the correct functional sequence for switching the drive on.

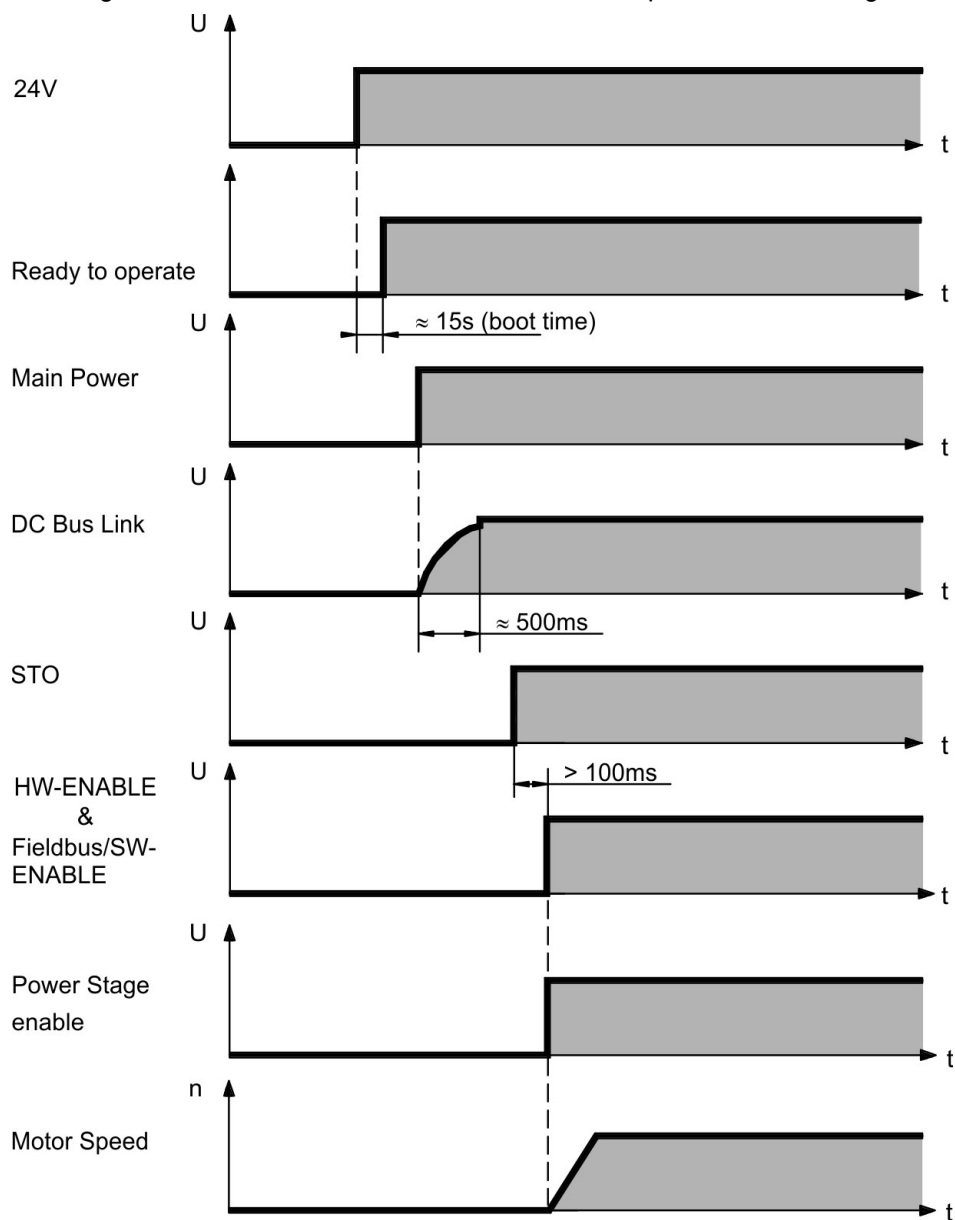

9.3.2 Switch-off behavior

NOTE

The drive's 24 V supply must remain constant. STO disables the power stage immediately. Configured Digital Inputs and fieldbus commands can be used to perform controlled stops.

9.3.2.1 Switch-off behavior using the **AXIS#.DIS** command

The enable/disable button in WorkBench issues a *AXIS#.DIS* command internally to the drive. See *WorkBench Online Help* for configuring inputs and software commands. Sometimes this enable signal is called "Software Enable" (SW-Enable).

AXIS#. DISMODE	<i>AXIS#.DISMODE</i> controls the behavior of the <i>AXIS#.DIS</i> command issued through WorkBench, or terminal, or fieldbus.
0	Disable axis immediately, if the drive detects the motor to be at zero velocity <i>AXIS#.ZEROV</i> or timeout occurs brake is applied. Category 0 stop according to IEC 60204 (→ # 21).
2	Use controlled stop to disable drive, if the drive detects the motor to be at zero velocity <i>AXIS#.ZEROV</i> or timeout occurs brake is applied. Category 1 stop according to IEC 60204 (→ # 21).

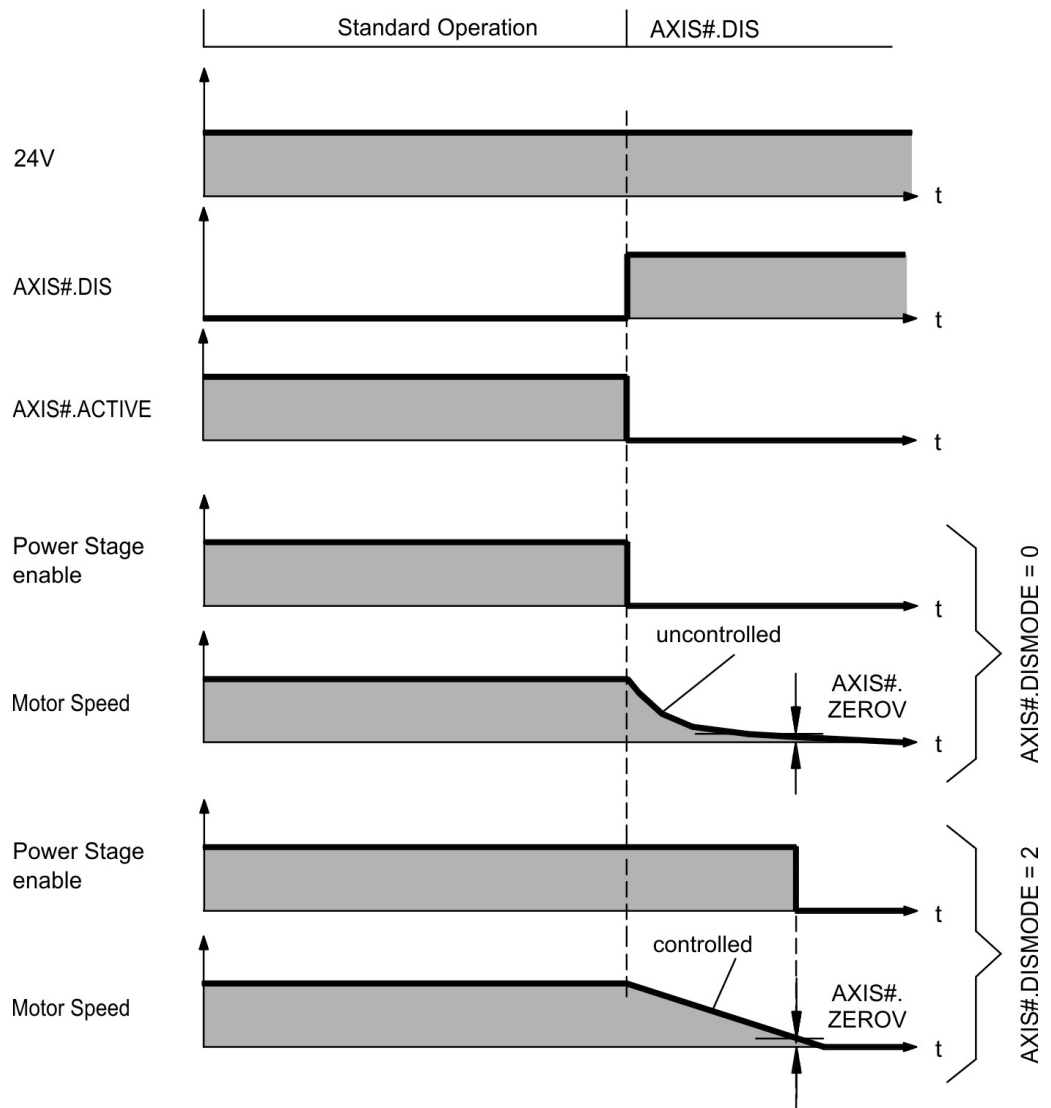

If the drive detects the motor to be at zero velocity (*AXIS#.ZEROV*) or timeout occurs (*AXIS#.ZEROT*), the motor brake is applied (→ # 91).

9.3.2.2 Switch-off behavior using a digital input (controlled stop)

This is a category 1 stop according to IEC 60204 (→ # 21).

A digital input can be configured to bring the motor to a controlled stop and then disable the drive and apply the holding brake.(if present). See the *WorkBench Online Help* for information on configuring Digital Inputs.

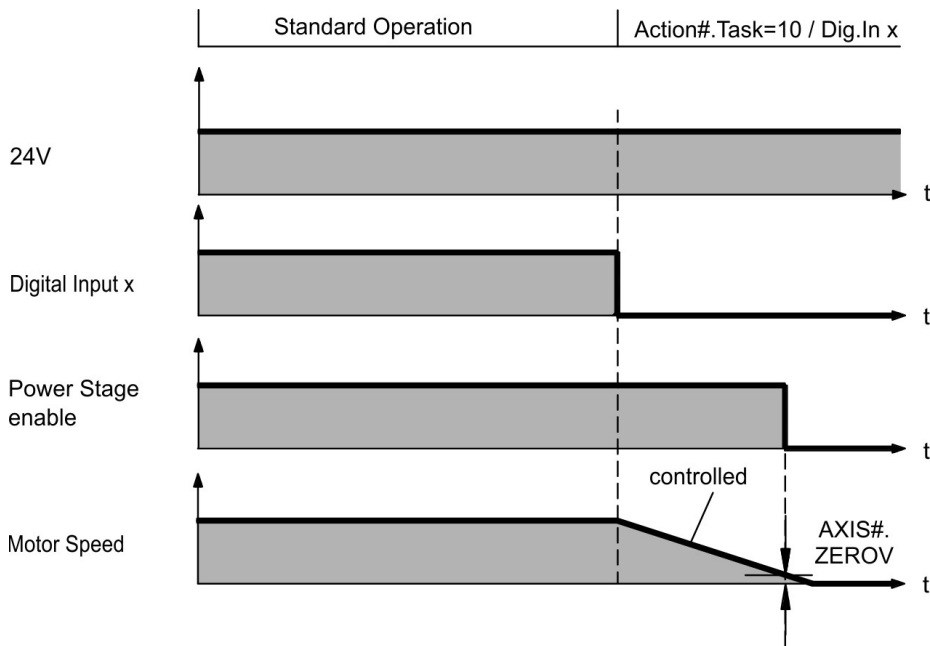

If the drive detects the motor to be at zero velocity (AXIS#.ZEROV) or timeout occurs (AXIS#.ZEROT), the motor brake is applied (→ # 91).

9.3.2.3 Switch-off behavior using STO input (uncontrolled stop)

This is a category 0 stop according to IEC 60204 (→ # 21).

The STO input disables the power stage immediately.

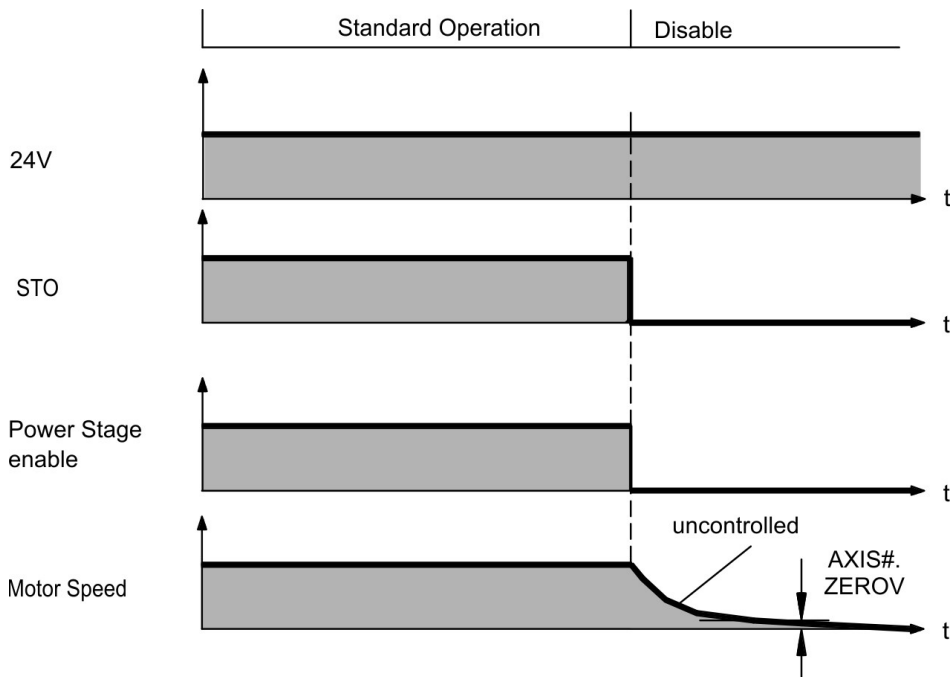

If the drive detects the motor to be at zero velocity (AXIS#.ZEROV) or timeout occurs (AXIS#.ZEROT), the motor brake is applied (→ # 91). Set parameter AXIS#.MOTOR.BRAKEIMM to 1 with vertical axes, to apply the motor holding brake immediately after STO.

9.3.2.4 Switch-off behavior in the event of a fault

The behavior of the drive always depends on the fault type and the setting of a number of different parameters (AXIS#.DISMODE, VBUS.UVFTHRESH, AXIS#.ZEROV, and others; see the *WorkBench Online Help* for more details). See the *Drive Fault and Warning Messages and Remedies* section of the *WorkBench User Manual* for a table describing the specific behavior of each fault. The next pages show examples for the possible fault behaviors. The fault relay output (DOUT9) switches the main contactor (Emergency Off circuit).

Switch-off behavior for faults that cause an immediate power stage disable

This is a category 0 stop according to IEC 60204 (→ # 21).

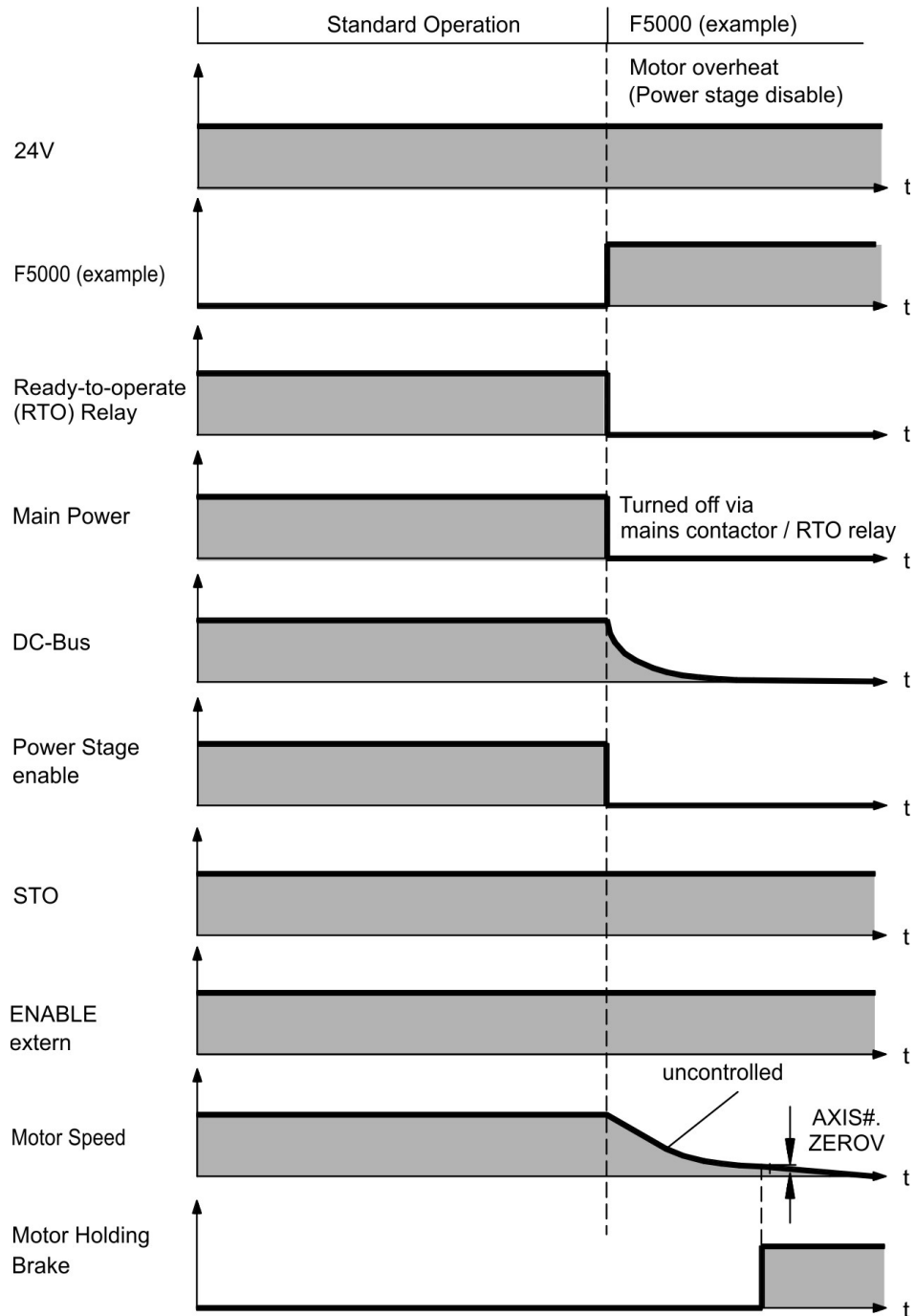

If the drive detects the motor to be at zero velocity (AXIS#.ZEROV) or timeout occurs (AXIS#.ZEROT), the motor brake is applied (→ # 91). Set parameter AXIS#.MOTOR.BRAKEIMM to 1 with vertical axes, to apply the motor holding brake immediately after faults.

Switch-off behavior for faults that cause dynamic braking

This is a category 2 stop according to IEC 60204 (→ # 21).

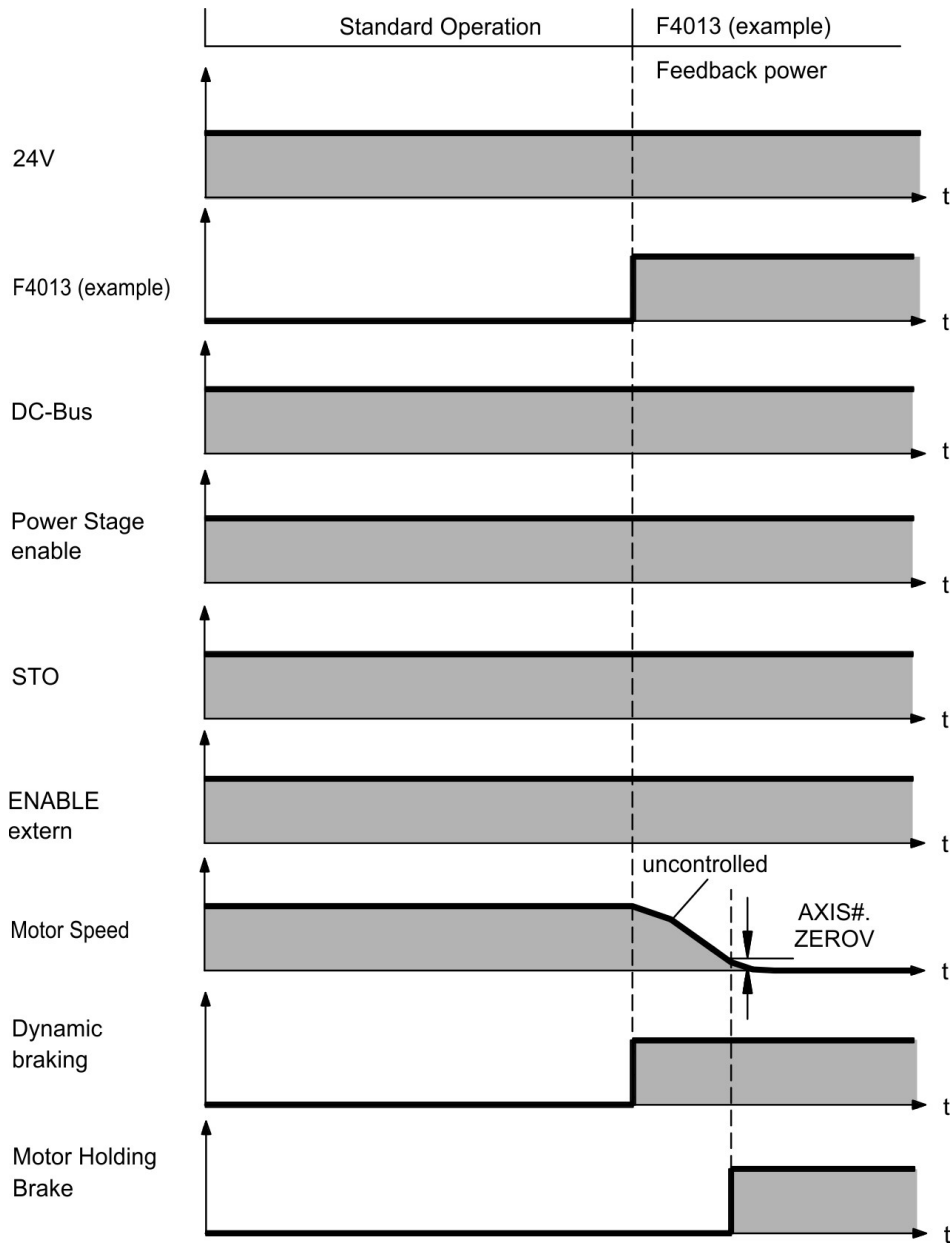

If the drive detects the motor to be at zero velocity (AXIS#.ZEROV) or timeout occurs (AXIS#.ZEROT), the motor brake is applied (→ # 91).

Switch-off behavior for faults that cause a controlled stop

This is a category 2 stop according to IEC 60204 (→ # 21).

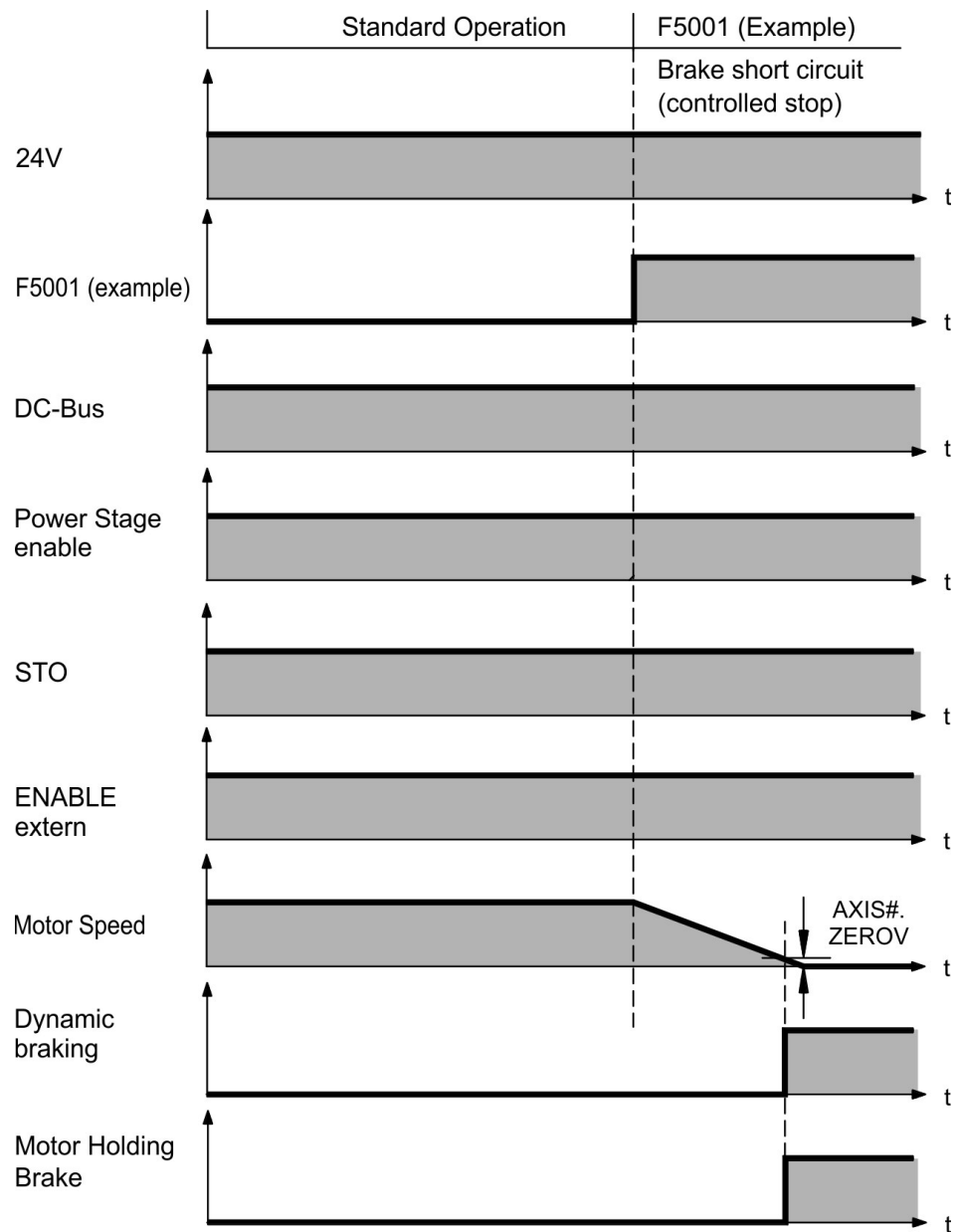

If the drive detects the motor to be at zero velocity (AXIS#.ZEROV) or timeout occurs (AXIS#.ZEROT), the motor brake is applied (→ # 91).

9.4 Fault and Warning Messages

9.4.1 Fault and warning messages AKD2G

A Fault is generally a notification of a critical system failure which will stop machine operation. Depending on the severity of the fault will depend on which system-stop mechanism is used.

A Warning is generally a notification to the user which is not critical and does not require the machine to immediately shut off.

Faults and Warnings follow the same pattern and are identified by a four digit code:

G G X X, where GG is a two digit group code, and XX is a two digit ID.

GG	Group	GG	Group
10	System	4#	Feedback (# indicates feedback number)
11	File	50	Motor
15	Hardware	55	Wake and Shake
20	Power	60	Motion
25	Temperature	70	Fieldbus
30	Software	90	Safety

The display on the front panel of the drive shows the code of the fault or warning that occurred. Navigate with B1 / B2 to the Fault screen to see a short description of the fault or warning.

Example: dual axes, Fault Axis 2

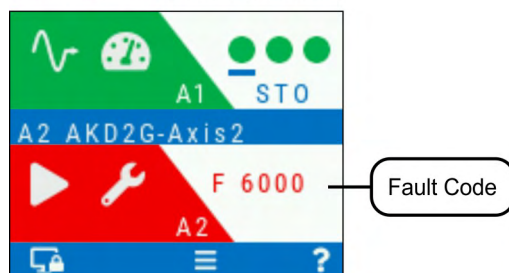

Example: single axis, Warning Axis 1

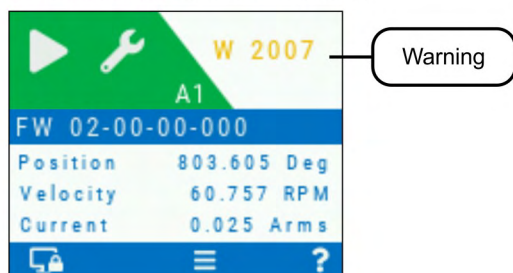

B1

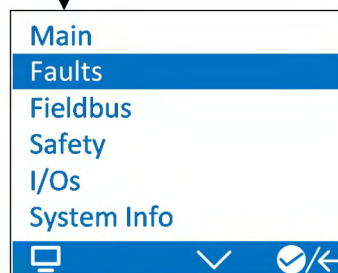

B2

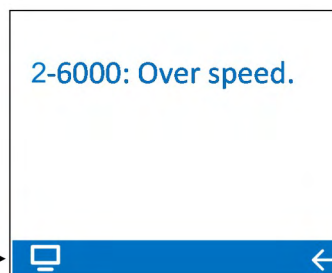

You can retrieve faults on a per-axis basis with the parameter: `AXIS#.FAULTS`, where # is the Axis number. For retrieving warnings use `AXIS#.WARNINGS`, or `DRV.WARNINGS`.

Multiple faults may be present when a fault condition is occurring. Check the WorkBench Fault Screen or read the status of `DRV.FAULTS` and `AXIS#.FAULTS` for the entire list of faults.

`DRV.FAULTS` will return all faults across all axes, with the format `#-GGXX` where # is the axis number and GGXX is the four digit fault/warning code.

NOTICE

Eliminate errors and faults in compliance with work safety rules. Troubleshooting only by qualified and trained staff.

NOTE

More information about fault messages, remedy and clearing faults can be found in the WorkBench User Manual .

9.5 Troubleshooting

Drive problems occur for a variety of reasons, depending on the conditions in your installation. The causes of faults in multi-axis systems can be especially complex. If you cannot resolve a fault or other issue using the troubleshooting guidance presented below, customer support can give you further assistance.

NOTICE

Eliminate errors and faults in compliance with work safety rules. Troubleshooting only by qualified and trained staff.

NOTE

More details on the removal of faults can be found in the WorkBench User Manual.

Problem	Possible Causes	Remedy
HMI message: Communication fault	<ol style="list-style-type: none"> wrong cable used, cable plugged into wrong position on drive or PC wrong PC interface selected 	<ol style="list-style-type: none"> plug cable into the correct sockets on the drive and PC select correct interface
Drive does not enable	<ol style="list-style-type: none"> HW Enable configured but not wired HW or SW Enable not set 	<ol style="list-style-type: none"> connect HW Enable to the selected input Apply 24V to HW Enable and select SW Enable in WorkBench / Fieldbus
Motor does not rotate	<ol style="list-style-type: none"> drive not enabled software enable not set break in setpoint cable motor phases swapped brake not released drive is mechanically blocked motor pole no. set incorrectly feedback set up incorrectly 	<ol style="list-style-type: none"> apply ENABLE signal set software enable check setpoint cable correct motor phase sequence check brake control check mechanics set motor pole no. set up feedback correctly
Motor oscillates	<ol style="list-style-type: none"> gain is too high (speed controller) feedback cable shielding broken AGND not wired up 	<ol style="list-style-type: none"> reduce AXIS#.VL.KP (speed controller) replace feedback cable join AGND to CNC-GND
Drive reports following error	<ol style="list-style-type: none"> Irms or Ipeak set too low current or velocity limits apply accel/decel ramp is too long 	<ol style="list-style-type: none"> verify motor/drive sizing verify that AXIS#.IL.LIMITN/P, AXIS#.VL.LIMITN/P are not limiting the drive reduce AXIS#.ACC/AXIS#.DEC
Motor overheating	<ol style="list-style-type: none"> motor operating above its rating motor current settings incorrect 	<ol style="list-style-type: none"> verify motor/drive sizing verify motor continuous and peak current values are set correctly
Drive too soft	<ol style="list-style-type: none"> AXIS#.VL.Kp (velocity) too low AXIS#.VL.Ki (velocity) too low filters set too high 	<ol style="list-style-type: none"> increase AXIS#.VL.KP (velocity) increase AXIS#.VL.KI (velocity) refer to documentation regarding reducing filtering (AXIS#.VL.AR*)
Drive runs roughly	<ol style="list-style-type: none"> AXIS#.VL.Kp (velocity) too high AXIS#.VL.Ki (velocity) too high filters set too low 	<ol style="list-style-type: none"> reduce AXIS#.VL.KP (velocity) reduce AXIS#.VL.KI (velocity) refer to documentation regarding increasing filtering (AXIS#.VL.AR*)

10 Safety Manual for FS2

Revision History for Safety Manual

Revision	Remarks
S201, 05/2021	Functional Safety Option 2

The Safety Manual is valid for:

AKD2G with Functional Safety Option 2 (FS2):

AKD2G - xxx - xxxxx - x2xx - xxxx

Integrated **SafeMotion Monitor (SMM)**, activation by digital I/O or FSoE

Safety Functions: STO, SS1-t, SBC, SBT, SDB; SIL3 PLe

Hardware Revision	Drive Firmware	Workbench	SAFEGRID	Safety Integration Version	SMM Firmware	SMM Revision
A	from 2.05	from 2.7	1.62.21	1.0.1.122	from 1.04	R4A

Note the list of limited safety features (Limitations, → # 283).

Contents:

10.1	General notes	143
10.2	Commissioning	147
10.3	Safety Functions Option 2 (I/O, FSoE, SIL3 PLe)	149
10.4	Settings	190
10.5	Validation	205
10.6	Operation	207
10.7	Safety Faults, Safety Warnings	209
10.8	Functional Safety Parameter Reference	214

10.1 General notes

Resulting Functional Safety classification (SIL and/or PL level) is calculated across the drive system. The drive system usually consists of

- motion controller (e.g. AKC/KAS),
- safety controller (e.g. KSM),
- servo drives (AKD2G) and servo motors (e.g. AKM2G),
- motor brakes, feedback systems,
- cables to connect drive and motor,
- sensors/actors.

The safety properties listed in this chapter can be reached with Kollmorgen components.

NOTICE

The user must ensure the compliance of the application with all relevant directives and local electrical code. The user is responsible for implementation and validation of the drive system and safety system.

Only properly qualified personnel are permitted to perform such tasks as installation, setup and verification/validation.

- Mechanical installation: only by qualified personnel with mechanical expertise according to IEC 60417-6183.
- Electrical installation: only by qualified personnel with electrotechnical expertise according to IEC 60417-6182.
- Parameterizing Functional Safety: only by trained personnel with expertise appropriate to the complexity and safety integrity level of the drive system.
- Verification/Validation: only by trained personnel after any changes to the installation. The expertise of the personnel must be appropriate to the complexity and safety integrity level of the drive system.

NOTE

Safe State: The safe state is always to remove the motor torque on all axes, to apply the brake(s), to deactivate all the safe digital outputs and to set the safe fieldbus connection to safe state (if applicable).

Fail-safe: I/O failure and internal failure (such as problems detected on the drive or on the safety system itself) lead to safe state.



CAUTION High electrical voltage!

Risk of electrical shock! The safety functions do not provide an electrical separation from the power output. If manual access to the motor or drive power terminals is necessary,

- disconnect the drive from mains supply,
- consider the discharging time of the DC-Bus link,
- ensure the cabinet is safely disconnected and protected against unintended switch-on (for instance, with a lock-out and warning signs).

10.1.1 Use as directed

Safety functions are intended to reduce the risk of the machine operation to the required tolerable risk. To achieve functional safety, the wiring of the safety circuits must meet the safety requirements of IEC 60204, ISO 12100 and ISO 13849.

NOTICE

- The network, where the drive is connected to, must be secured according to state-of-the-art information technology security requirements.
- The user IT specialists shall analyze whether further security requirements are applicable to ensure functional safety.
- The drive firmware can be updated. The parameter sets must be reloaded, verified and proof tested before normal operation is started.
- The SafeMotion Monitor (SMM) firmware can be updated by a trained engineer. For training and certification please contact Kollmorgen. The safety parameter set must be reloaded, verified and proof tested before normal operation is started.
- In certain types of machinery, two motors drive a single mechanical axis. It is the responsibility of the user to ensure that a fault reaction on the first motor-drive set is also carried out on the second motor-drive set and vice-versa. Safe I/O and/or a safe field bus such as FSoE can be used to achieve this.

10.1.2 Prohibited use

The safety functions must not be used if the drive is to be made inactive for Emergency-Off situations. In an Emergency-Off situation, the main relay is switched off (by the Emergency-Off button).

The device does not require maintenance. Opening the device voids the warranty. In case of damage or malfunction the drive must be sent for repair or must be replaced.

NOTICE

The drive must not be connected directly to the Internet. If the network, where the drive is connected to, is not secured according to state-of-the-art information technology, this could be a functional safety risk. The SafeMotion Monitor (SMM) does not fulfill requirements regarding the IEC 62443.

10.1.3 Abbreviations used for functional safety

More abbreviations see (→ # 14).

Abbreviation	Meaning
A#, AXIS#	A# or AXIS# are placeholders for the axis number. Used with parameters (AXIS#.SAFE.STO.ACTIVE) or signal names (STO-A-A#)
(→ # 53)	"see page 53" in this document
→ xyz	"see chapter xyz" in this document
CCF	Common cause failure
CRC	Cyclic Redundancy Check
DGUV	Deutsche Gesetzliche Unfallversicherung
FS2	Functional Safety Option 2 (Safe Stop functions)
FSoE	Fail safe over EtherCAT
HFT	Hardware fault tolerance
MTTFd	Mean time to dangerous failure
OSSD	Output Switching Signal Device
PELV	Protective Extra Low Voltage
PFHd	Probability of dangerous failure per hour
PL	Performance Level
SBC	Safe Brake Control
SBT	Safe Brake Test
SC	Systematic Capability
SDB	Safety Dynamic Break
SFF	Safe failure fraction
SIL	Safety Integrity Level
SMM™	SafeMotion™ Monitor
SRA CRC	Safety-related application CRC
SS1	Safe Stop 1
SS1-t, SS1(c)	Safe Stop 1 time based
STO	Safe Torque Off
TM	Mission time

10.1.4 Enclosure, wiring

Enclosure

Since the drive meets IP20, you must select an enclosure that permits safe operation of the drive. The enclosure must at least meet IP54 .

Transport in accordance with IEC 61800-2	
NOTE	Transport only in the manufacturer's original recyclable packaging.
Temperature	-25 to +70 °C, maximum rate of change 20 K/hour, class 2K3.
Relative Humidity	max. 95% at +40°C, no condensation, class 2K3.
Shock	NOTICE: Avoid shocks while transporting. AKD2G modules are tested for environmental class 2M1 of IEC 60721-3-2.
Storage in accordance with IEC 61800-2	
Temperature	-25 to +55 °C, maximum rate of change 20 K/hour, class 1K4.
Relative Humidity	5 to 95% , no condensation, class 1K3.
Operation in accordance with IEC 61800-2	
Environmental class	Environmental class 3K3
Temperature	Internal regen resistor used: <ul style="list-style-type: none"> ● 0 to +40 °C under rated conditions ● +40 to +60 °C with current derating 3 % per Kelvin Internal regen resistor not used: <ul style="list-style-type: none"> ● 0 to +50 °C under rated conditions ● +50 to +60 °C with current derating 2 % per Kelvin
Relative Humidity	5 to 85%, no condensation, IEC 61800-2 class 3K3
Site altitude	<ul style="list-style-type: none"> ● Up to 1000 m above mean sea level (AMSL): no restriction ● 1,000 to 2,000 m AMSL: power derating 1.5%/100 m ● Maximum altitude: 2000 m AMSL
Drive EMC immunity	Increased immunity according to EN 61800-5-2
Drive Pollution level	Pollution level 2 as per IEC 60664-1
Drive Vibration class	Class 3M1 according to IEC 61800-2
Drive Shock class	Class L according to IEC 61800-2
Drive protection class	IP20 according to IEC 60529
Enclosure	Minimum cabinet size (WxHxD): 406 x 406 x 254 mm
Enclosure protection	At least IP 54 according to IEC 60529

Wiring

Wiring inside the specified enclosure (IP54) must meet the requirements of the standard IEC 60204-1 and ISO 13849-2 (Table D.4). Use copper wires, 0.5 mm² (20 awg), wire ferules. Maximum distance for unshielded I/O lines is 3 m inside the cabinet. If the I/O cable leaves the cabinet, it must be EMC shielded.

Wiring outside the specified enclosure must be laid durably protected from outside damage (for example, by laying the cable in a duct, placed in different sheathed cables, or protected individually by grounding connection).

NOTICE

When wiring the digital inputs and outputs, take care, that short circuits between the inputs, the outputs or to a supply line are avoided.

10.2 Commissioning

NOTICE

The safety features of the AKD2G only fulfill their purpose and can only function properly when the machine was developed according to ISO 12100, ISO 13849 and EN 62061. Depending on the use case further standards may apply.

The machine manufacturer is responsible for proper and safe commissioning. Violating the according standards can result in potential unsafe condition or dangerous behavior of the machine. Only properly qualified and trained personnel are permitted to perform the following tasks.

10.2.1 First time commissioning

- **Actions prior to commissioning:**
 - A risk assessment must be carried out, covering all risks originating the machine.
 - Safety functions for risk reduction require sufficient definition such as functionality, PLr / SILCL, reaction times and so on. Analyze your machine accordingly.
 - The safety functions must be specified (components, SIL/PL, PFHd, category, TM, CCF measures, proof test intervals like SBT, MTTFd, DC, combinations of functions etc.)
 - Take precautionary measures against foreseeable misuse or manipulation bypassing the safety functions.
 - It must be calculated and analyzed, whether the specified safety chain is sufficient to reach the required PLr / SILCL.
 - A commissioning plan must be set up, that specifies all actions of the verification and validation.
 - Take quality assurance measures for all steps such as reviews, FMEAs, independent personnel and four-eyes principle.
- **Actions during commissioning:**
 - Verify that the hardware configuration is set up as specified (components, architecture, wiring, CCF measures etc.).
 - Verify that the software configuration is done according to the specification. Suitable measures can be reviews, black-box tests, simulations and function tests. Make sure that only the required functions are configured.
 - Verify if the safety functions get executed as expected and whether the configuration is suitable for the application. Suitable measures are function tests and fault injection tests (error condition tests).
 - Validate the machine (→ # 205) Test the final product with all safety functions and in all operation modes and states.
Validate that the safety functions do not interfere with other functions or each other in an undesired way. If used, check if all instances are assigned to the right use cases. Pay special attention to the correct use of safety function muting.
 - Make sure all safety functions and all possible situations are covered by the validation process.
 - Document all actions and decisions according to the requirements of the standards (→ # 206).
 - The switching state of the pulse inhibitor (AXIS#.SAFE.STO.ACTIVE, → # 233) can be mapped to a safe digital output of the AKD2G.
- **Actions after commissioning:**
 - Document and validate all information relevant to the end user in a suitable way. This includes capabilities and limits of the safety functions as well as maintenance instructions.
 - Change default passwords and store them inaccessible to unqualified or unauthorized personnel. Protect the hardware from unwanted or unauthorized modifications.

For detailed information refer to the applicable standards.

10.2.2 Recommissioning

- Recommissioning after disassembling and reassembling or after drive replacement:
 - Verify the correct reassembling according to the original specification.
 - Verify that the correct safe parameter package was uploaded to the right drive.
 - Check all components and wiring for correct installation and for signs of damage.
 - Carry out function tests and fault injection tests again.
 - Validate all functions and combinations of functions again.
- Recommissioning after long standstill:
 - Check all components for their TM and signs of damage or unacceptable wear. Components that have exceeded their TM or show signs of damage need replacement.
- Recommissioning after modification:
 - Any modification to a safety function requires a complete reevaluation and revalidation
 - according to (First time commissioning, → # 147).
 - Alternative: Set up a modification process by carrying out an analysis to identify all possible influences on safety. Reverify the affected aspects and revalidate the machine.
 - Update your documentation and end user information accordingly.

NOTICE

Modifying safety functions could void certifications and approvals from notified bodies. Contact your notified body for further information.

Only properly qualified and trained personnel are permitted to perform these tasks.

10.2.3 Diagnostic Testing of safe inputs, safe outputs and STO

Safe inputs require test pulses (OSSD, → # 158) and there is no further requirement for diagnostic testing of the input wiring. There may however be additional diagnostic requirements for the device connected to the safe input.

Safe outputs emit test pulses (OSSD, → # 158) and there is no further requirement for diagnostic testing of the output wiring. There may however be additional diagnostic requirements for the device connected to the safe output.

STO is continuously diagnosed internally and there is no further requirement for diagnostic testing.

10.2.4 Diagnostic Testing of safe brake control

The BRAKE+ and BRAKE- emit test pulses (Test pulses, → # 172) and there is no further requirement for diagnostic testing of the brake wiring. There is a periodic requirement to test the brake itself, see documentation on (SBC (Safe Brake Control), → # 171) and (SBT (Safe Brake Test), → # 179).

10.3 Safety Functions Option 2 (I/O, FSoE, SIL3 PLe)

The safety functions on the AKD2G with functional safety option 2 are certified.

NOTICE

The drive is ready to operate with pre-configured STO function.

Each safety function can either be activated through FSoE or digital input or both. The source of activation shall be configured inside the safety parameters and it needs to match the system requirements.

The user must review the default setting and check if it matches his requirements. In case it doesn't match, the safety parameters need to be adapted and validated.

For digital I/O commanding use WorkBench to map safety functions to safe I/Os.

With [FSoE](#) the safety functions can be activated by using the safePLC of the FSoE Master.

With dual axis drives every safety function can be activated for one axis or for both axes (axis 1 or axis 2 or axes 1&2).

NOTE

The systematic safety integrity indicated by the systematic capability can be achieved only when the instructions and constraints are observed. Where violations occur, the claim for systematic capability is partially or wholly invalid.

Standards

Standard	Content
ISO 13849:2015	Safety of machinery: Safety-related parts of control systems
IEC 62061:2015	Functional safety of electrical/electronic/programmable electronic safety-related systems

Available Safety Functions

Activation and reachable Performance level / Category (→ # 150).

Abbr.	Function	Category	Refer to
STO	Safe Torque Off	Safe Stop	(→ # 162)
SS1-t	Safe Stop 1, time based	Safe Stop	(→ # 166)
SBC	Safe Brake Control	Safe Stop	(→ # 171)
SBT	Safe Brake Test	Safe Stop	(→ # 179)
SDB	Safe Dynamic Brake	Safe Stop	(→ # 185)

Rotary switches S1/S2 and push-buttons B1/B2

Switches and buttons in the device front (→ # 190) are used to set the SafeID (→ # 191).

10.3.1 Safety properties overview

General properties	Values
Hardware fault tolerance (ISO 61508)	HFT = 1
Classification element (ISO 61508)	type B subsystem
Systematic capability	SC = 3
Mission time	TM = 20 Years
Proof test interval	> 20 Years
Safe failure fraction	SFF = 99 %
PFH fraction of SIL 3	1.7 %
Probability of dangerous failure per hour	$PFH_d = 1.7E-09$ 1/h
Mean time to dangerous failure	$MTTF_D = 55.6$ Years
Diagnostic coverage	$DC_{AVG} = 99.6$ %
Common cause failure (see annex F of ISO 13849-1)	CCF: score = 75

Calculation example for safety chain PFH_d :

- Safety PLC that is the FSoE master.
- EtherCAT cabling etc.
- Two drives configured for STO activation over FSoE.

Contribution to the safety chain of the safety PLC: PFH_{PLC} refer to manufacturer data.
 Contribution to the safety chain of using FSoE via EtherCAT cabling etc. is $1.0E-9$ 1/hr.
 Contribution to the safety chain of the two drives PFH_d is $2 \times 1.7E-9$ 1/hr.

Total value: $PFH_d = PFH_{PLC} + 2 \times 1.7E-9$ 1/hr + $1.0E-9$ 1/hr = $PFH_{PLC} + 4.4E-9$ 1/h

10.3.1.1 Activation by FSoE

Safety Function	ISO 13849-1	IEC 62061	maximum response time	Comment
STO	PLe, Cat.4	SIL 3	< 10 ms	
SS1-t	PLe, Cat.4	SIL 3	< 10 ms	followed by STO*

*configured delay (time to STO) see [AXIS#.SAFEPARAM.SS1_#.TIMETOSTO](#)

10.3.1.2 Activation by Safety Functions

Safety Function	ISO 13849-1	IEC 62061	maximum response time	Comment
SBC with one brake	PLd, Cat.3	SIL 2	< 10 ms	need to be configured for activation during STO process
SBC with two brakes	PLe, Cat.4	SIL 3	< 10 ms	
SDB single channel	PLd, Cat.3	SIL 2	< 10 ms	
SDB dual channel	PLe, Cat.4	SIL 3	< 10 ms	

10.3.1.3 Activation by safe digital inputs

NOTICE

When activated by using safe digital inputs, a safety device with test pulses is required (OSSD, (→ # 158)).

Safe inputs must be driven from a source containing test pulses, this can be a safe digital output or a safety device with suitable outputs. If the SMM is configured to detect distinct test pulses, then no fault exclusion is required against wiring shorts and cross-talk.

Electromechanical devices such as relays and emergency stop switches can be wired in series with a source of test pulses; the B10d value of the mechanical contacts may limit the achievable safety level.

Safety Level	Single safe input	Dual safe inputs
SIL2, PLd Cat. 3	✓	✓
SIL3, PLe Cat. 4	—	✓

Dual channel activation

Safety Function	ISO 13849-1	IEC 62061	maximum response time	Comment
STO	PLe, Cat.4	SIL 3	< 10 ms	
SS1-t	PLe, Cat.4	SIL 3	< 10 ms	followed by STO*

*configured delay (time to STO) see [AXIS#.SAFEPARAM.SS1_#.TIMETOSTO](#)

Dual channel for axis1 and axis2, Safety Control with electronic outputs, automatic restart:

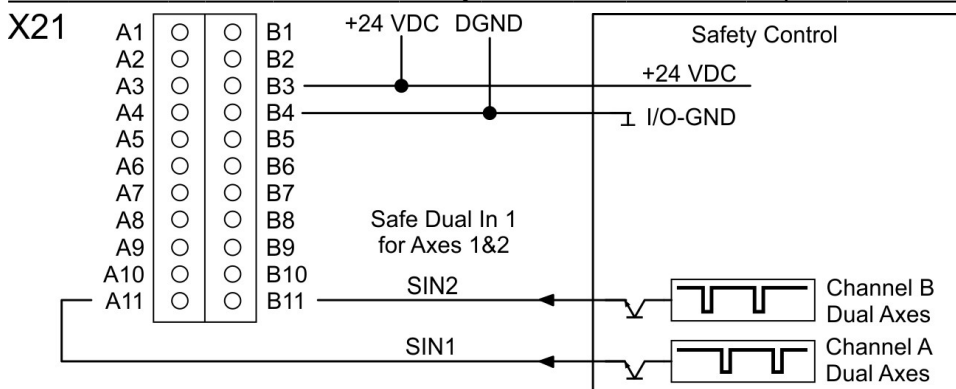

Dual channel for axis1 and axis2, Safety Control with relay contacts, automatic restart:

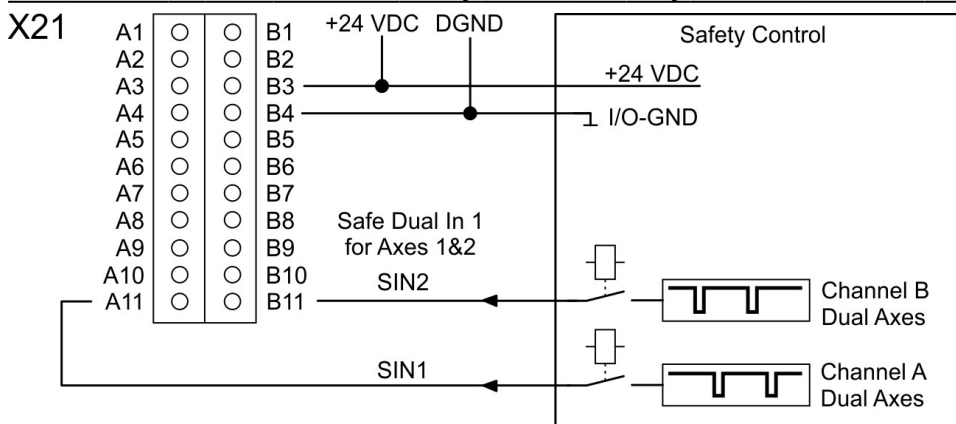

Dual channel for axis1 and axis2, Emergency Stop, automatic restart:

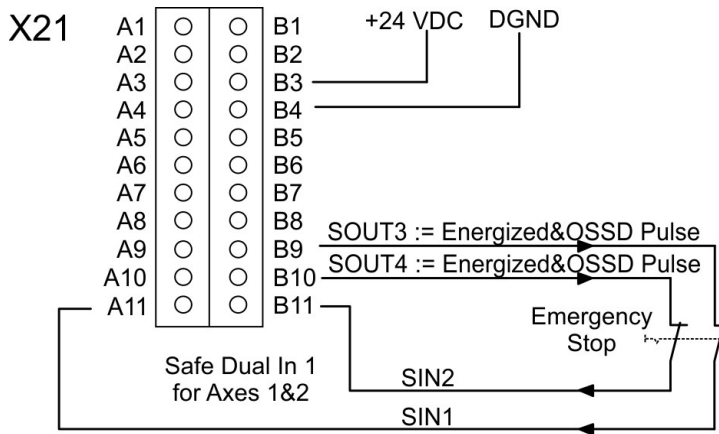

Dual channel for axis1 and axis2, Emergency Stop, manual restart:

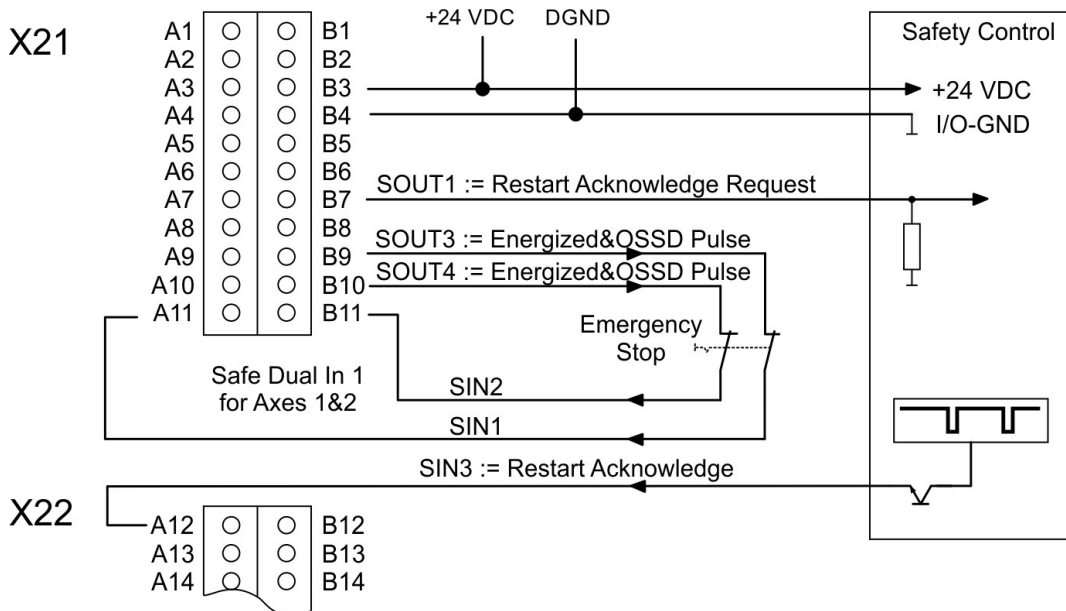

Single channel activation

Safety Function	ISO 13849-1	IEC 62061	maximum response time	Comment
STO	PLd, Cat.3	SIL 2	< 10 ms	
SS1-t	PLd, Cat.3	SIL 2	< 10 ms	followed by STO*

*configured delay (time to STO) see [AXIS#.SAFEPARAM.SS1_#.TIMETOSTO](#)

Single channel for axis1 and axis2, Safety Control with electronic outputs, automatic restart:

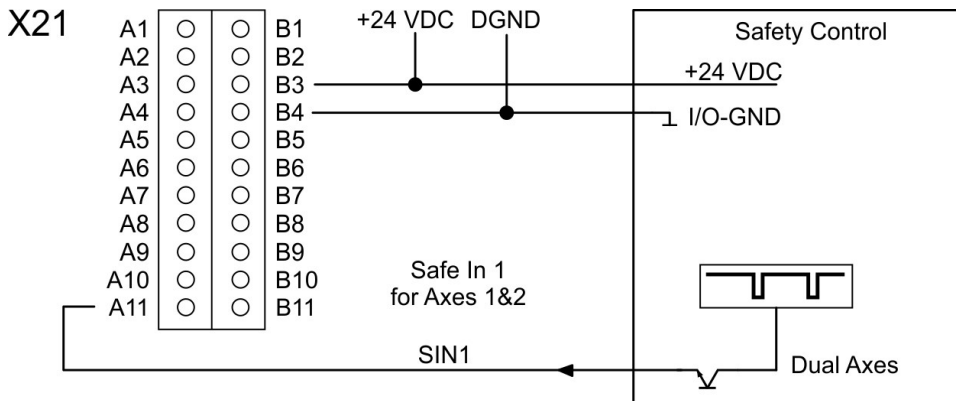

Single channel, 2 axes, Safety Control with relay contacts, automatic restart:

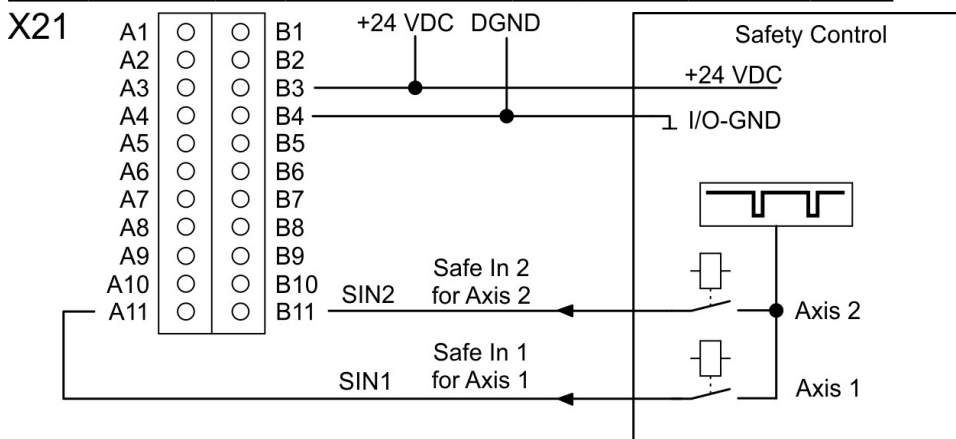

Single channel for axis1 and axis2, Emergency Stop, automatic restart:

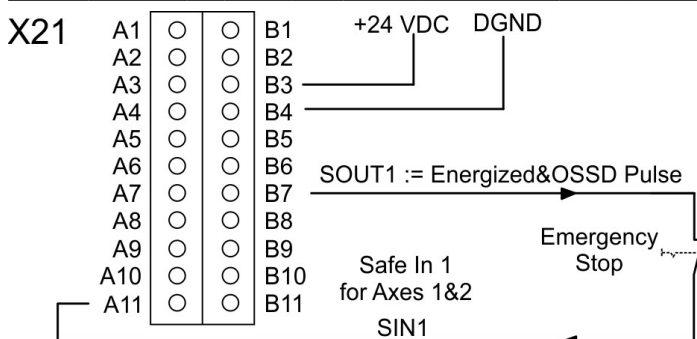

Single channel for axis 1, Emergency Stop, manual restart:

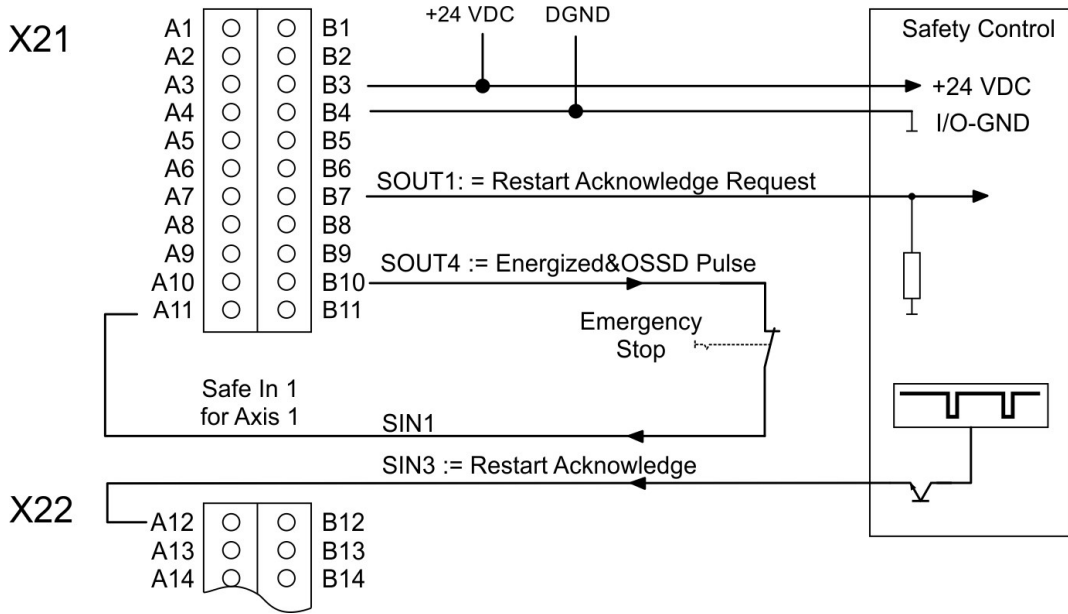

10.3.1.4 Safety function response time calculation

Basic values, process safety time (PST)

Abbreviation	Process	PST
SIN_PST	Single Input / Dual Input	2.8 ms
Func_PST	Safety function computation	1 ms
STO_Out_PST	STO output change	2.2 ms
FSoE_PST	Minimum FSoE cycle time	5 ms
Brake_Out_PST	Brake output change	4 ms
SOUT_PST	Safe Output change	4 ms
SIN_Fault_Reaction_Time	Safe Input Fault Reaction	5.1 ms

Calculation Examples

Time to be set with safety parameters:

- t1 (brake time delay) see [AXIS#.SAFEPARAM.SBC.BRAKETIMEDELAY](#)

- t2 (time to STO) see [AXIS#.SAFEPARAM.SS1_#.TIMETOSTO](#)

Activated by safe inputs (dual or single channel)

Functions	Calculation	Response time
STO without SBC	$SIN_PST + Func_PST + STO_Out_PST$	6 ms
SBC with 1 or 2 brakes	$SIN_PST + Func_PST + Brake_Out_PST$	7.8 ms
STO with SBC without SDB	$SIN_PST + Func_PST + STO_Out_PST + t1$	6 ms + t1
STO with SBC with SDB	$SIN_PST + Func_PST + STO_Out_PST$	6 ms
SS1-t with STO (time to activate STO)	$SIN_PST + Func_PST + t2$	3.8 ms + t2
SS1-t with STO with SBC without SDB (time to change brake output)	$SIN_PST + Func_PST(SS1-t) + t2 + Func_PST(STO) + Brake_Out_PST$	8.8 ms + t2

Activated by FSoE

Functions	Calculation	Response time
STO without SBC	$FSoE_PST + Func_PST + STO_Out_PST$	8.2 ms
SBC with 1 or 2 brakes	$FSoE_PST + Func_PST + Brake_Out_PST$	10 ms
STO with SBC without SDB	$FSoE_PST + Func_PST + STO_Out_PST + t1$	8.2 ms + t1
STO with SBC with SDB	$FSoE_PST + Func_PST + STO_Out_PST$	8.2 ms

10.3.2 Technical Data

10.3.2.1 Safe digital inputs

The drive supports 4 safe digital inputs. The safe inputs are configurable for single channel or dual channel, for axis1 or for axis2 or for both axes. The safety function mapped to the inputs can be configured to "permanent high" or "permanent low".

- Reference ground is DGND
- Galvanic isolation for 60 VDC
- Activation delay about 5 μ s
- Deactivation delay about 500 μ s
- Use 24 VDC \pm 15% PELV power supply
- High level > 15 VDC, > 2 mA
- Low level < 5 VDC, < 1 mA
- OSSD test pulses required (\rightarrow # 158)

Safety Level	Single safe input	Dual safe inputs
SIL2, PLd Cat. 3	✓	✓
SIL3, PLe Cat. 4	—	✓

Pinout

Conn./Pin	Signal	Description
X21 B3	+24 V	+24 VDC for digital I/O
X21 B4	DGND	Ground for digital I/O
X21 A11	SIN1	Configurable, for example SS1 channel A axes 1&2
X21 B11	SIN2	Configurable, for example SS1 channel B axes 1&2
X22 A12	SIN3	Configurable, for example STO channel A axis 2
X22 B12	SIN4	Configurable, for example STO channel B axis 2

Input parameters (setting see "Parameters Editor" (\rightarrow # 197))

Parameter	Name	Description	Default
SAFEPARAM.SINDUAL1.EN	Dual safe input 1	associates safe inputs SIN1 and SIN2 to dual channel input 1 for an axis.	enabled
SAFEPARAM.SINDUAL2.EN	Dual safe input 2	associates safe inputs SIN3 and SIN4 to dual channel input 2 for an axis.	enabled
SAFE.IOERROR-ACKSOURCE	Failure acknowledgement via I/O	Specifies the safe digital input, which can be associated for the acknowledgement of the IO failures.	off
SAFEPARAM.SIN.DISTINCT-PULSE	Digital input distinct test pulse monitoring	Specifies, if the safe digital input monitoring for distinct test pulses is enabled	enabled

NOTE

For wiring strategy to reach the necessary SIL/PL refer to (\rightarrow # 151).

For safety parameter description refer to the *Parameters Reference Guide* (\rightarrow # 214).

If dual channel mode is selected, the drive supervises whether the two inputs are in a different state for longer than 100 ms. If they are different for more than 100 ms, a fault reaction is triggered (see specific safety function for details).

NOTE

If you configure the safe inputs to accept non-distinct test pulses then you should make a fault exclusion on the input wiring or provide other justification that input wiring faults cannot be dangerous such as cable segregation or individual shielding.

NOTE

The used Safety Controller must be compatible to OSSD (Output Switching Signal Device) according to IEC 61496-1. OSSD requirements (\rightarrow # 158).

10.3.2.2 Safe digital outputs

The drive has 2 paired or 4 single safe digital outputs, in order to signal the safety condition of the drive to an external safety PLC or activate external devices (for example an SDB Module). The safe digital outputs are current sourcing when activated. They are deactivated to indicate a fault condition or activate a safety device.

- Reference ground is DGND (X21/B4)
- Galvanic isolation for 24 VDC from PE
- Use PELV power supply, 24 V \pm 15%
- Activation delay depends on safety function
- High Level 23.5 V \pm 15%, 172 mA
- Low level < 1 VDC, < 1 mA
- Emits OSSD test pulses according to IEC 61496-1 (\rightarrow # 158)

If an inductive load (relay or similar) is used, a freewheeling diode must be added to the load.

Safety Level	Single safe output	Dual safe outputs
SIL2, PLd Cat. 3 ✓	✓
SIL3, PLe Cat. 4	—	✓

Pinout

X21	Signal	Description
B7	SOUT1	Configurable, for example STO status of axis 1
B8	SOUT2	Configurable, for example STO status of axis 2
B9	SOUT3	Configurable
B10	SOUT4	Configurable

Output parameters (setting see "Parameters Editor" (\rightarrow # 197))

Parameter	Name	Description	Default
SAFEPARAM.SOUTDUAL#.EN	Dual safe output	associates two safe outputs to a dual channel output for axis #.	disabled
SAFEPARAM.SOUTDUAL#.SOURCE	Source selection of safe dual output	Selects the state of a safety function, which is provided for a safe dual output 1/2.	off
SAFEPARAM.SOUT#.SOURCE	Source selection of safe digital output	Selects the state of a safety function, which is provided for SOUT1 to 4.	off

NOTE

For safety parameter description refer to the *Parameters Reference Guide* (\rightarrow # 214).

10.3.2.3 Factory Default Settings

NOTICE: The drive is ready to operate with pre-configured STO function.

Item	Parameter	Factory default
SafeID	SAFE.ID	Rotary switches: "01" (S1 = 0, S2 = 1).
FSoE Address	AXIS#.SAFE.FSOE.CONNECTIONID	Axis 1: 101 (SafeID*100+1) Axis 2: 102 (SafeID*100+2)
SIN1, 2	AXIS#.SAFEPARAM.STO.SAFEINPUT	Axis 1: STO
SIN3, 4		Axis 2: STO (dual axis drives only)
SOUT1, 2, 4	SAFEPARAM.SOUT#.SOURCE	0xFF (On)
SOUT3	SAFEPARAM.SOUT#.SOURCE	0x00 (Off)
Password	"SafeMotionMonitorxyz" "xyz" = last three digits of drive serial number	

10.3.2.4 OSSD

Test pulses on safe digital inputs (SIN1 to SIN4)

NOTE

The used Safety Controller must be compatible to OSSD (Output Switching Signal Device) according to IEC 61496-1.

Safety controllers check their outputs periodically during the normal operation. Their self-test processes create pulses to the safe inputs of the drive.

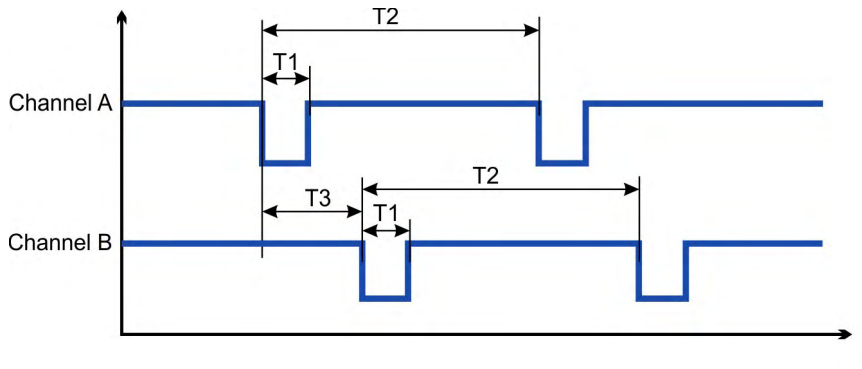

Timing	min	max
T1	150 μ s	1 ms
T2	100 ms	1 s
T3	> T1 (non-overlapping)	

NOTE

Test pulses with $150 \mu\text{s} \leq T1 \leq 1 \text{ ms}$ and $T2 \geq 100 \text{ ms}$ will not have any influence to the safety function. Test pulses, which are outside of this specification, will switch the safety function, but will not create a dangerous situation.

The SMM software enters the I/O Failure State (fault reaction time $\leq 2\text{ms}$)

- if no test pulse is detected for a period of 5 seconds,
- if three test pulses on different channels overlap three times in succession.

Test pulses on safe digital outputs (SOUT1 to SOUT4)

The safe digital outputs can be used as 24 V source voltage to be switched by an external safety relay to STO inputs.

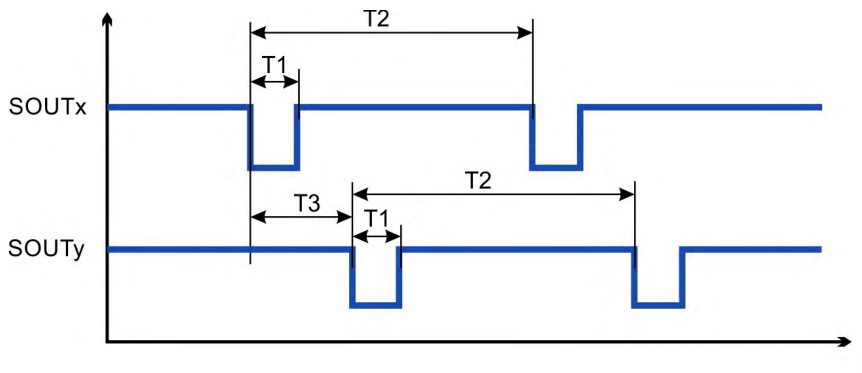

Timing	min	max
T1	450 μ s	550 μ s
T2	810 ms	990 ms
T3	> T1 (non-overlapping)	

NOTE

The output test pulses are compatible with the safe digital input requirements. There is only one test pulse on all four outputs at a time. They do not overlap each other. Be sure to use a force-guide relay, converter, or controller that does not respond to these test pulses.

10.3.2.5 FSoE

Safety over EtherCAT®

AKD2G drives (connectivity option **E**) are connected as slaves to the EtherCAT® network by using RJ45 connectors X11 (out port) and X12 (in port).

- Interface details see (→ # 104).
- FSoE address setting see (→ # 192).
- FSoE drive profile see *AKD2G EtherCAT Manual*.
- Activation of FSoE for safety functions:(→ # 267)
- Parameter Download through FSoE see (→ # 201)

NOTE

The FSoE safety architecture of the AKD2G is supported from TwinCAT 3 (Beckhoff). For use of an FSoE master from another manufacturer, contact our customer service.

The SMM implements an FSoE slave with a single endpoint per axis. The SMM implements the FSoE drive profile and supports fixed data structures for the safe fieldbus only. If configured the software inverts the error bit of the FSoE status word at the associated safe digital output. The output is off if the error bit is set.

The software of the SMM responds to FSoE Messages within 2 ms after receiving the messages by using the Safe Fieldbus Interface. Examples for response time calculation depending on the safety function combination see (→ # 155).

The SMM software receives this data in the parameter state of the FSoE Protocol:

- The checksum of the parameters and the drive type identification. In this case the software uses this checksum to validate the parameters received by using CoE.
- No parameter block or a zero checksum (without other parameter).
In this case the software uses the parameters transmitted by using other means.

The required data to create the EtherCAT Slave Information file (ESI file) are provided, including the safety parameters for the transmission by using the safe fieldbus.

FSoE telegram frame RxPDO

Size per frame per axis 88 bits results in total 176 bits (22 Bytes) for both axes. If an axis is not used, the data are transmitted anyway.

FSoE telegram frame TxPDO

Size per frame per axis 248 bits results in total of 496 bits (62 Bytes) for both axes. If an axis is not used, the data are transmitted anyway.

Related parameters

Name	Default	Parameter
Activation for safety functions	0	(→ # 267)
Application parameter length	-	(→ # 219)
Communication parameter length	-	(→ # 219)
Connection ID	-	(→ # 220)
Connection type (Slave)	-	(→ # 220)
Protocol Version	-	(→ # 221)
FSoE address	-	(→ # 222)
Safety-related application CRC	-	(→ # 222)
Command word send by master	-	(→ # 223)
Actual watchdog time	100ms	(→ # 223)

Activate FSoE in WorkBench

Select Safety Parameterization view (→ # 193). Choose Common (1) and General(2)



Parameters Editor

[Learn more about this topic](#)

Configuration of the safety parameters.

Axes	Categories
Common 1	General 2
Axis 1	Inputs
Axis 2	Outputs
	Encoders

[Goto Safety Parameter Download](#)

[SafelD: 1] Common > General



Type: **Kollmorgen AKD2G SMM**
 Description: **Kollmorgen AKD2G SafeMotion Monitor**
 Import file: -

Parameter	Value	Unit
Common - General		
SafelD	1	
Safe Fieldbus Activation	Activated	
I/O Failure Acknowledgement	Not used	

10.3.2.6 Motor brake requirements

Zero, one or two brakes can be configured under safe brake control SBC (→ # 171). The brake must be a fail-safe brake with multiple springs. A fail-safe brake is applied when the 24 V brake voltage is removed.

Important notes

NOTICE

External brakes must allow operation at 100 % duty cycle at 24 V. In case of a failure the brake must be rated for the full current at full time.

Brakes are subject to wear. Wear increases by frequency and intensity of use. Avoid overloading the brakes by reducing motor speed with electrical braking before engaging the brakes when possible.

When a brake is used to reduce a risk (usage with SBC), it is part of a safety chain. As part of a safety chain, the brake must fulfill the requirements for functional safety such as category and PFHd depending on the target SIL or PL (SIL/CL / PLr).

The brake PFHd value shall not occupy more than 50% of the PFHd value of the whole safety chain. Keep in mind that the PFHd-value of a brake depends on frequency of usage. Kollmorgen FV type brakes (contact Kollmorgen customer support) offer a B10d of >15,000,000 use cycles. Assuming a use rate n_{op} of 2/h will result in a PFHd of 13.3 FIT (see calculation example below).

Example: $PFHd = 1 / [B10_d / (0.1 * n_{op})] = 1 / [15 * 10^6 / (0.1 * 2/h)] = 13.3 \text{ FIT}$

Connection

- The first motor brake (build into the motor) can be connected to X1 respectively X2 connectors (→ # 91).
- For SIL 3 a second (external) motor brake for an axis is required. For single axis drives this brake can be connected to X4 (→ # 93). For dual axis drives the additional brake must be controlled from another source (e.g. from the other axis or externally from a safety controller). The brakes can be mapped to an axis with WorkBench.

Brake	Signal	Connector / Pin	
		Single Axis Drive	Dual Axes Drive
1	BRAKE1+	X1/B+	
	BRAKE1-	X1/B-	
2	BRAKE2+	X4/3	X2/B+
	BRAKE2-	X4/2	X2/B-

Configuration

Safety functions can be configured to use SBC (→ # 171) as part of its fault reaction. You have the option of configuring the fault reaction of a safety function to use

- No brake.
- One brake per axis. For axis 1 use BRAKE1, for axis 2 use BRAKE2. These brake lines are normally pre-wired on the motor cable.
- Two brakes on a single axis drive. BRAKE1 is normally pre-wired on the motor cable, BRAKE2 is brought out to a separate connector X4.
- Two brakes on axis 1 of a dual axis drive. BRAKE1 is normally pre-wired on the motor cable, BRAKE2 must be wired across from X2.
- Two brakes on axis 2 of a dual axis drive. BRAKE2 is normally pre-wired on the motor cable, BRAKE1 must be wired across from X1.

10.3.3 STO (Safe Torque Off)

Safe Torque Off description for drive option Functional Safety 2 or 3.

10.3.3.1 Description

STO turns off the drive output stage that powers the motor. STO function corresponds to an uncontrolled stop according to IEC 60204-1, stop category 0.

Important Notes



WARNING No Brake Power!

Serious injury could result when a suspended load is not properly blocked. The drive cannot hold a vertical load when STO is active.

- Add a safe mechanical blocking (for instance, a motor holding brake).
- Configure Safe Brake Control SBC (→ # 171).

NOTICE

It is not possible to perform a controlled brake according to IEC 60204-1 category 1, if STO function is active as standalone function. If controlled braking category 1 is necessary, you should use the SS1-t function (→ # 166).

Function Input/Output variables



Inputs

- **STO Activate** can be activated by
 - FSoE,
 - SS1,
 - a fault reaction or
 - safe digital inputs (must be mapped).
- **STO Restart Acknowledge** is used for manual restart. The signal can be activated by
 - FSoE or
 - safe digital inputs (must be mapped).

Outputs

- **STO Active**: logical status of the STO function
- **STO Restart Request** is used for manual restart. The signal can be evaluated by using FSoE or safe digital outputs (must be mapped).

Number of instances

One instance per axis.

10.3.3.2 Activation

Activation by FSoE	<ul style="list-style-type: none"> ● For drive profile overview refer to (→ # 159). ● For setup and handling refer to the <i>AKD2G EtherCAT Manual</i>.
Activation by safe digital inputs	<ul style="list-style-type: none"> ● Review the enclosure and wiring instructions (→ # 146). ● Technical data of the safe inputs (→ # 156). ● Notes for activation by safe inputs (→ # 151).
Activation with configurable time after SS1-t	Refer to <ul style="list-style-type: none"> ● SS1-t function (→ # 166)

10.3.3.3 Restart

Restart can be set as "automatic restart" or "manual restart" (STO Restart Mode, [AXIS#.SAFEPARAM.STO.RESTARTACKMODE](#)).

- With manual restart a restart request signal will be send to the safety control, when STO is deactivated. The axis waits for the restart acknowledge and axis enable to restart.
- With automatic restart the axis restarts when STO is deactivated and axis is enabled.

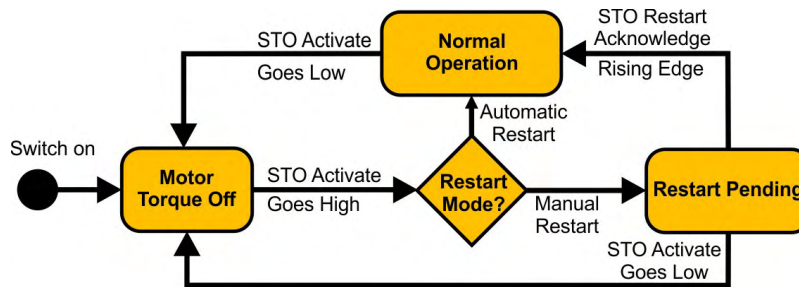

10.3.3.4 Timing

Timing for activation by SS1-t: Refer to SS1-t function (→ # 166).

Timing for activation by FSoE: Refer to the *AKD2G EtherCAT Manual*.

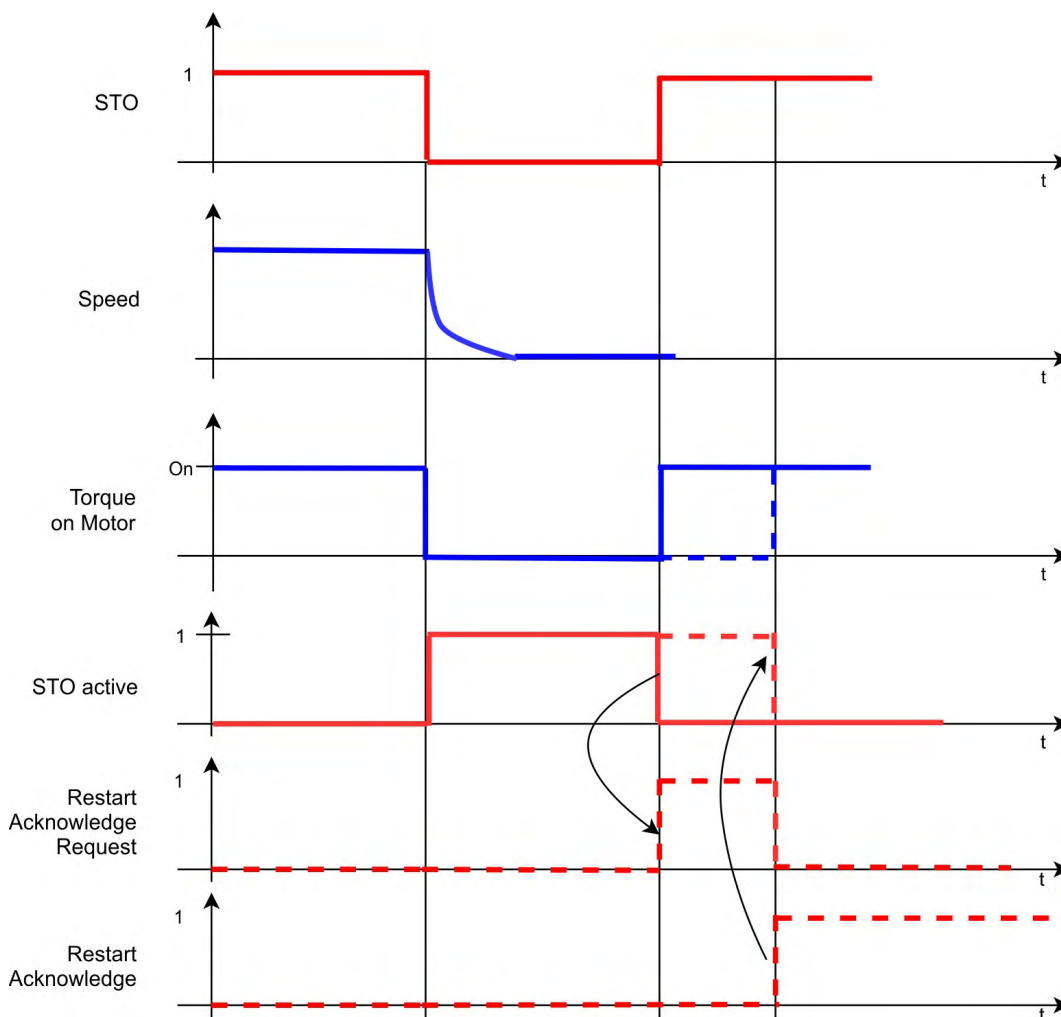

10.3.3.5 Related Parameters

Safety Parameters

Name	Variables	Default	Parameter
Function Activation	-	1 (Ready)	(→ # 246)
Safe Input	-	Axis 1 – 5 (Safe Dual 1) Axis 2 – 6 (Safe Dual 2)	(→ # 249)
FSoE	-	0 (Not used)	(→ # 246)

Diagnostic Parameters

Name	Variables	Default	Parameter
Function Actual Active Status	-	-	(→ # 233)
Reportfault	-	-	(→ # 234)

With manual restart, map the Restart Request Source to a safe output, refer to (→ # 197).

10.3.3.6 Setup in Workbench

Select the drive and open the Safety Parameterization view (→ # 197).

Choose the axis (1), category (2) and STO function (3). The instance number (4) is not applicable for STO.

Parameters Editor [Learn more about this topic](#)

Configuration of the safety parameters.

Common	Categories	Safe Stop	Instances
Axis 1	Safe Stop	STO (Safe Torque Off)	Instance 1 (Fault Reaction)
Axis 2		SS1 (Safe Stop 1)	
		SBC (Safe Brake Control)	
		SBT (Safe Brake Test)	
		SDB (Safe Dynamic Brake)	

[Goto Safety Parameter Download](#)

[SafeID: 1] Axis 1 > Safe Stop > STO (Safe Torque Off) > Instance 1 (Fault Reaction)

Type: **Kollmorgen AKD2G SMM**
 Description: **Kollmorgen AKD2G SafeMotion Monitor**
 Import file: -

Parameter	Value	Unit
Axis 1 - Safe Stop - STO - Instance 1 (Fault Reaction)		
Function Activation	Ready for Activation	
Safe Input	Safe input 2 (SIN2)	
FSoE	Not Used	
Restart Acknowledge Behavior	Manual Restart	
Restart Acknowledge Source	Safe input 3 (SIN3)	

Note: If you want to have one dual input (e.g. SIN1/SIN2) activate STO for both axis 1 and axis 2, then you must set the activation parameter for both axes to the identical input.

10.3.3.7 Fault Reaction/ Failure Messages

If dual channel mode is selected, the AKD2G supervises if the two inputs are in a different state for longer than 100 ms. If the two inputs are in different state for more than 100 ms, an I/O failure activates SS1_1 and then the axis torque is switched off by STO.

An I/O failure warning is messaged when the AKD2G is disabled or a fault when the AKD2G is enabled and [AXIS#.SAFE.STO.REPORTFAULT](#) is set to 1.

10.3.3.8 Safety Diagnostic for safe I/Os view in WorkBench

The WorkBench view "Safety Diagnostic - Safe I/O" shows the current status on the safe inputs and the logical status of the STO function for every axis.

Safe I/O
 Safety functions monitoring

General | **Safe I/Os**

sts

10.3.3.9 Safety Properties

Refer to (Safety properties overview, → # 150).

10.3.4 SS1-t (Safe Stop 1)

SS1-t (time controlled) description for drive option Functional Safety 2 or 3.

10.3.4.1 Description

With the time based function "Safe Stop 1" (SS1-t) the drive is stopped by a controlled braking with the configured emergency brake ramp. When the time t_{SS1} is elapsed, STO is activated.

SS1 function corresponds to a controlled braking according to IEC 60204-1, stop category 1. The controlled braking is no functional safe process. The STO function which is activated when time t_{SS1} is elapsed, is a safe function.

Function Input/Output variables

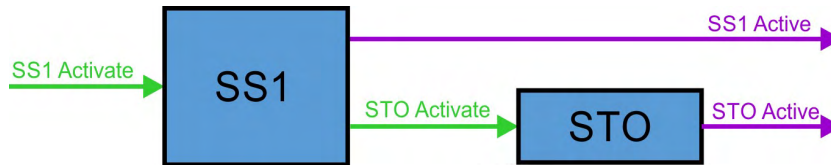

Inputs

- **SS1 Activate** can be activated by
 - FSoE,
 - I/O failure (instance 1 only) or
 - safe digital inputs (must be mapped).
- **STO Activate** is activated by SS1

Outputs

- **SS1 Active**: logical status of the SS1 function
- **STO Active**: logical status of the STO function

Number of instances

Three instances per axis.

10.3.4.2 Activation

NOTE

To use SS1-t, Velocity & Deceleration Monitoring must be disabled in the safety parameters on a FS3 drive. On a FS2 drive, only SS1-t is available.

The safety function can be mapped with WorkBench or by using FSoE to the safe digital inputs or other functions.

If SS1_2 or SS1_3 is set to "Not Used", the corresponding FSoE activation bit is ignored even if SAFEFIELDBUS.ACTIVATION is 1.

Activation by FSoE	<ul style="list-style-type: none"> ● For drive profile overview refer to (→ # 159). ● For setup and handling refer to the <i>AKD2G EtherCAT Manual</i>.
Activation by safe digital inputs	<ul style="list-style-type: none"> ● Review the enclosure and wiring instructions (→ # 146). ● Technical data of the safe inputs (→ # 156). ● Notes for activation by safe inputs (→ # 151).

10.3.4.3 Safety Properties

Refer to (Safety properties overview, → # 150).

10.3.4.4 Restart

Restart can be set as "automatic restart" or "manual restart" (STO Restart Mode, [AXIS#.SAFEPARAM.STO.RESTARTACKMODE](#)).

- With manual restart a restart request signal will be send to the safety control, when STO is deactivated. The axis waits for the restart acknowledge and axis enable to restart.
- With automatic restart the axis restarts when STO is deactivated and axis is enabled.

10.3.4.5 Timing

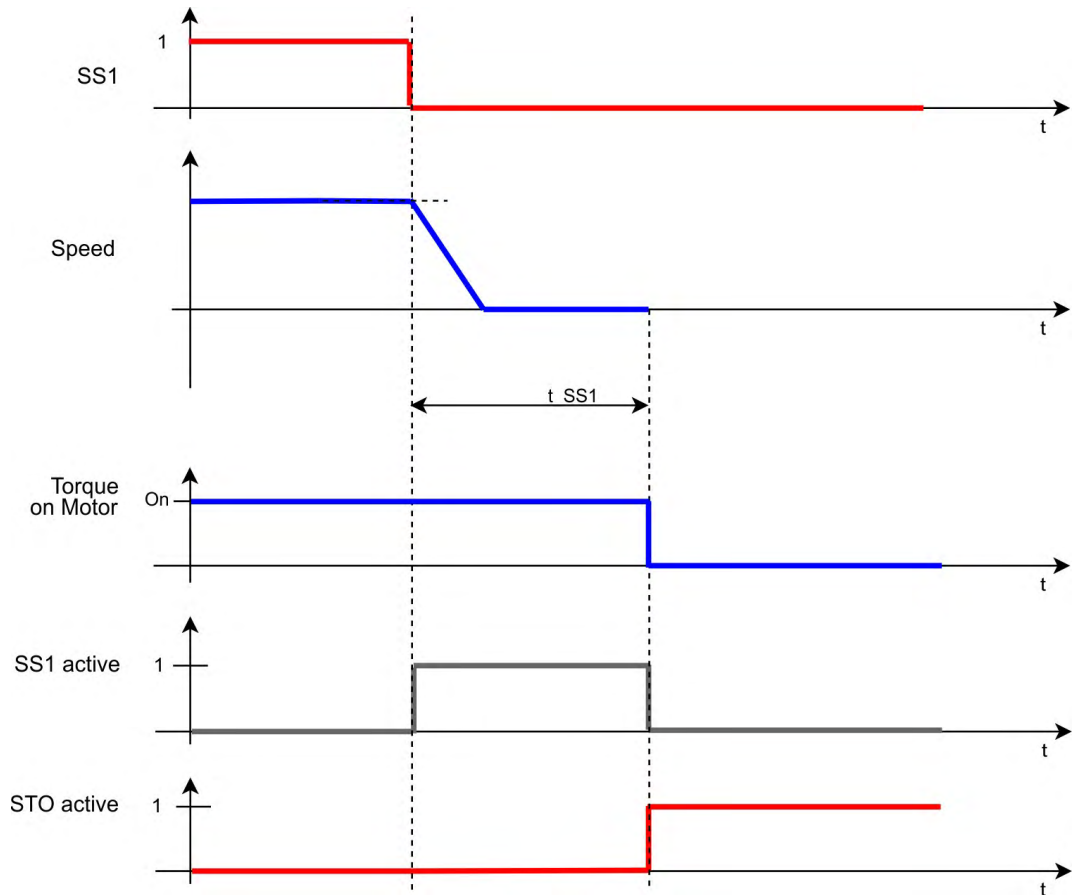

Notes:

- After SS1 was activated, it finalizes even when the request (SS1_Activate) is reset before STO is activated.
- The additional time for the optionally closing of the brakes is not included in this diagram.

10.3.4.6 Related Parameters

Safety Parameters

Name	Variables	Default	Parameter
Function Activation	-	Inst. 1: 1 (Ready) Inst. 2,3: 0 (Never)	(→ # 244)
Safe Input	-	0 (Not used)	(→ # 245)
FSoE	-		(→ # 244)
Time To STO	t_SS1	2 ms	(→ # 245)
Velocity & Deceleration Monitoring	-	0 (Disabled)	

Diagnostic Parameters

Name	Variables	Default	Parameter
Function Actual Active Status	-	-	(→ # 230)
Function Internal Status	-	-	(→ # 232)

Device Parameters

Name	Variables	Default	Parameter
Deceleration Mode		0 (Drive driven)	(→ # 233)
Deceleration Ramp		9999.946 rpm/s	(→ # 231)

10.3.4.7 Setup in Workbench

Select the drive and open the Safety Parameterization view (→ # 197).

Choose the axis (1), category (2), SS1 function (3) and the instance number (4).

Parameters Editor [Learn more about this topic](#)

Configuration of the safety parameters.

Axes	Categories	Safe Stop	Instances
Common	General	STO (Safe Torque Off)	Instance 1 (Fault Reaction)
Axis 1	Safe Stop (2)	SS1 (Safe Stop 1) (3)	Instance 2
Axis 2 (1)		SBC (Safe Brake Control)	Instance 2
		SBT (Safe Brake Test)	
		SDB (Safe Dynamic Brake)	

[Goto Safety Parameter Download](#)

[SafeID: 1] Axis 1 > Safe Stop > SS1 (Safe Stop 1) > Instance 1 (Fault Reaction)

User Units (for information only)

Position: N/A Velocity: N/A Acceleration: N/A

Type: **Kollmorgen AKD2G SMM**
 Description: **Kollmorgen AKD2G SafeMotion Monitor**
 Import file: -

Parameter	Value	Unit
Axis 1 - Safe Stop - SS1 - Instance 1 (Fault Reaction)		
Function Activation	Ready for Activation	
Safe Input	Not Used	
FSoE	Not Used	
Time to STO (t_SS1)	2	ms
Velocity & Deceleration Monitoring		
Velocity Zero Window (n_Zero_SS1)	1	Velocity User Units
Time for Velocity Zero (t_L_SS1)	1	ms
Deceleration Limit (a_SS1)	0	Acceleration User Units
Time Delay Deceleration Monitoring (t_D_SS1)	1	ms

[Validation Results \(0\)](#)

Device Related Parameters (2)

Mode:

Deceleration Ramp: rpm/s

If one dual input (e.g. SIN1/SIN2) shall activate SS1-t for both axis 1 and axis 2, then set the Activation parameter for both axes to the identical input (e.g. Safe Dual Input 1).

10.3.4.8 Fault Reaction/ Failure Messages

If dual channel mode is selected, the AKD2G supervises if the two inputs are in a different state for more than 100 ms. If the two inputs are in different state for more than 100 ms, an I/O failure activates SS1_1 and then the axis is switched off by STO.

An I/O failure warning is messaged when the AKD2G is disabled or a fault when the AKD2G is enabled and [AXIS#.SAFE.STO.REPORTFAULT](#) is set to 1.

SS1 Instance 1 can be configured as the fault reaction for other safety functions. Functions which support this feature are SS2, SSR, SDI, SLA, SAR, SLI and SLP.

10.3.4.9 Safety State/ Status signals

The signal [AXIS#.SAFE.SS1#.ACTIVE](#) can be monitored by safe digital outputs with OSSD pulses (→ # 158). The status signal must be mapped to the safe digital output. Two outputs can be combined to a dual channel output. For parameter description refer to (→ # 214).

10.3.5 SBC (Safe Brake Control)

Safe Brake Control description for drive option Functional Safety 2 or 3.

10.3.5.1 Description

The safety function SBC (Safe Brake Control) is used for controlling the brakes wired to X1, X2 or X4 of the AKD2G. The connected brake is engaged and released by switching both lines (BR+ and BR-).

- The safety function SBC makes a motor with a motor brake suitable for the usage scenarios A1, A2, E1, E2, E3 according to DGUV.
- The safety function SBC makes a motor with a motor brake and a second brake on the same axis suitable for the usage scenarios A1, A2, A3, E1, E2, E3 according to DGUV.
- The brake can be configured with or without (SDB (Safe Dynamic Brake), → # 185).
- For requirements to the motor brakes refer to (Motor brake requirements , → # 161).

Association of brake outputs to drive axes

Drive Type	Brake 1	Brake 2	max. SBC Safety Level
Single Axis	Axis 1 (X1)	Axis 1 (X4)	Axis 1 : SIL3 / PL _e
Dual Axes	Axis 1 (X1)	Axis 2 (X2)	Axis 1 : SIL2 / PL _d Axis 2: SIL2 / PL _d
Dual Axes	Axis 1 (X1)	Axis 1 (X2)	Axis 1 : SIL3 / PL _e Axis 2 : no brake

NOTE

To achieve SIL 3 / PL_e for SBC,

- two brakes per axis must be used. With one brake the axis can reach SIL 2 / PL_d only.
- the brake function must be tested periodically with SBT (→ # 179)

Important Notes

NOTICE

Hoist and crane support: The drive will safely ensure a holding position, as long as SBC (braking ramp, delay time) is configured correctly.

- Any brake must be connected to one of the SBC interfaces (X1, X2, X4).
- The user is responsible for the execution of the safe brake test SBT (→ # 179).

NOTE

For requirements to the motor brakes refer to (→ # 161).

Function Input/Output variables

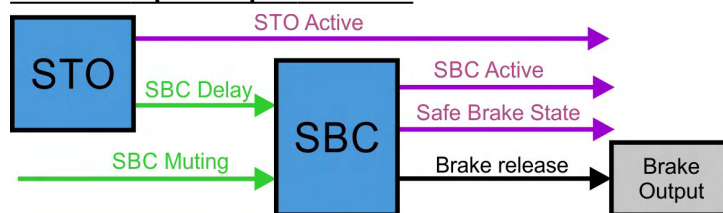

Inputs

- **SBC Delay**: brake delay t_{SBC}
- **SBC Muting** can be used for enabling manual override of the brakes while STO is active. Muting can be activated by FSoE or safe digital inputs (must be mapped).

Outputs

- **STO Active**: logical status of the STO function
- **SBC Active**: logical status of the SBC function
- **Safe Brake State**: state of the brake outputs (24V or 0V)

Number of instances

One instance per axis.

10.3.5.2 Test pulses

Test pulses are applied to the Brake+ and Brake- outputs (X1, X2, X4) alternately to ensure valid feedback. The test pulses are 1ms at the bottom but are 3 ms long due to their slow edges.

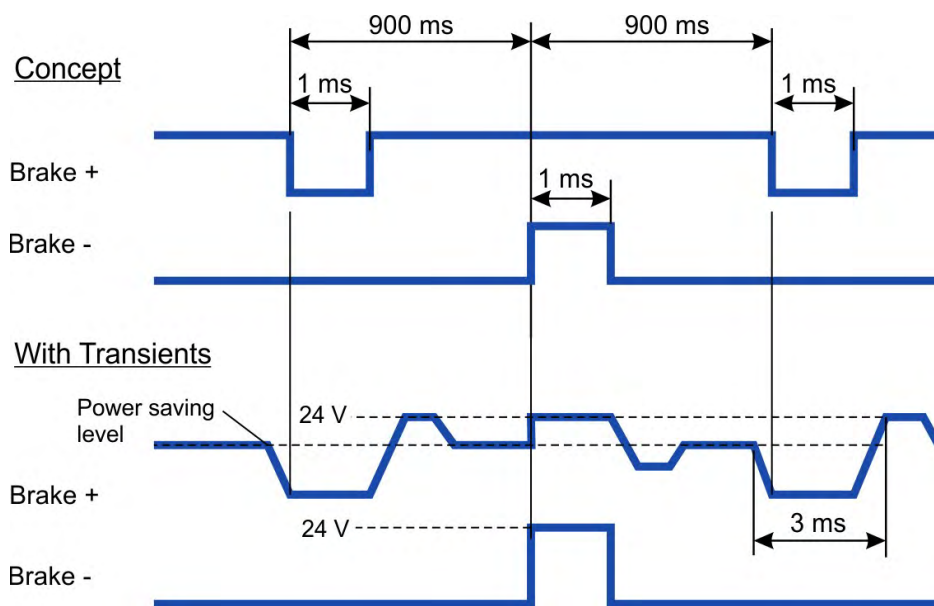

10.3.5.3 Activation

SBC for one or two brakes can be configured to be activated during STO process.

The controlled brake can be configured to be engaged while motor torque is available (STO not active yet) or after STO became active (no motor torque).

NOTE

The safety function must be mapped with WorkBench or by using FSoE to the STO function.

Example:

STO activated by safe digital inputs, one axis, SIL3 PLe, SBC with two brakes, SBT, without SDB

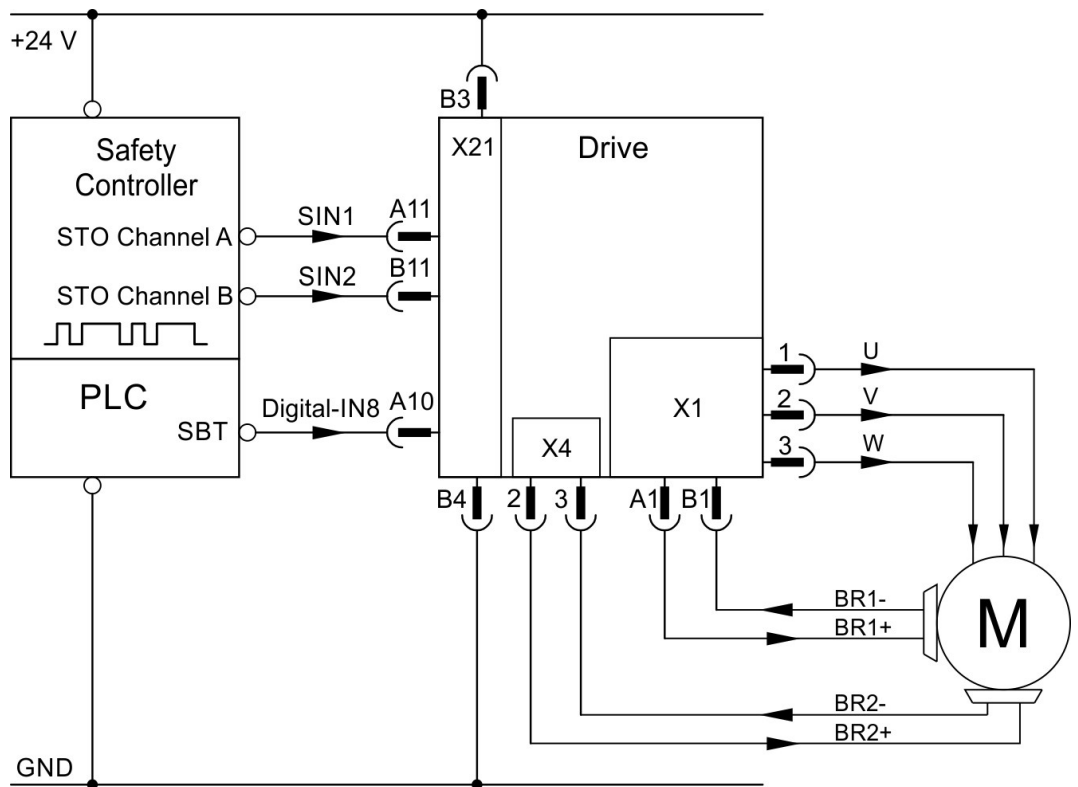

10.3.5.4 Restart

The brakes controlled by SBC will disengage simultaneously with the deactivation of STO if [AXIS#.SAFE.STO.REPORTFAULT](#) is set to 0.

If [AXIS#.SAFE.STO.REPORTFAULT](#) is set to 1, the brake will release when the axis is enabled again. See STO (→ # 164).

10.3.5.5 SBC Muting function

For servicing purposes manual control of brakes may be necessary.

When SBC muting is active, the brakes can be overwritten even if STO/SBC is active. The SBC active signal will be suppressed and manual control via WorkBench is possible.

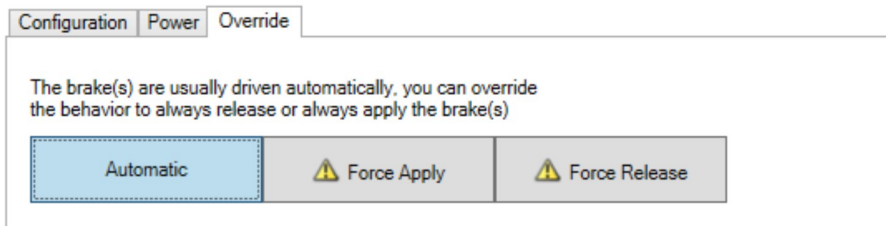

With SBC muting not active while STO/SBC is active, it is prohibited to control the brakes manually via WorkBench.

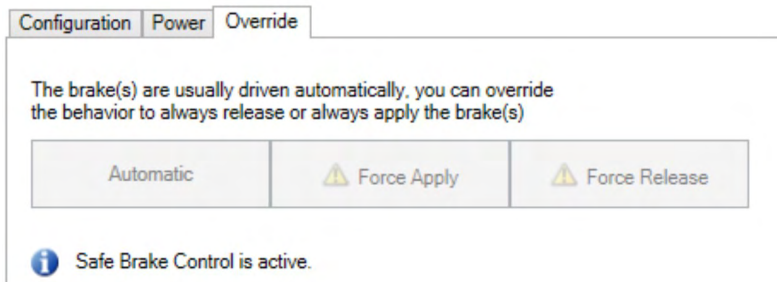

NOTICE

Overwriting the brake(s) behavior may create unsafe situations and/or damage. If the axis is used for a vertical load, forcing the brake(s) to release may damage the load.

- Only use this function when safety is ensured by other measures.
- Deactivate SBC muting before reentering normal operation.

When SBC muting is active and brake control is set to Automatic, during normal operation, the brake(s) will still be applied immediately when STO gets activated.

10.3.5.6 Related Parameters

Safety Parameters

Name	Variables	Default	Parameter
SBC Brake 1		1	(→ # 237)
SBC Brake 2		0	(→ # 237)
Brake Delay	tSBC	100 ms	(→ # 236)
SBC Muting	-	0	(→ # 238)

Diagnostic Parameters

Name	Variables	Default	Parameter
Function Actual Active Status	-	-	(→ # 227)
Safe Brake State	-	-	(→ # 217)

Device Parameters

Name	
BRAKEx.AXIS	For device parameters refer to WorkBench online help for more information.
AXIS#.MOTOR.BRAKE	

10.3.5.7 Timing, SS1 followed by SBC without SDB

SBC is configured “without SDB”:

1. When STO is requested (STO becomes active), the brake output is deactivated first.
2. Then, the system waits for the configured brake delay to elapse to deactivate the STO.

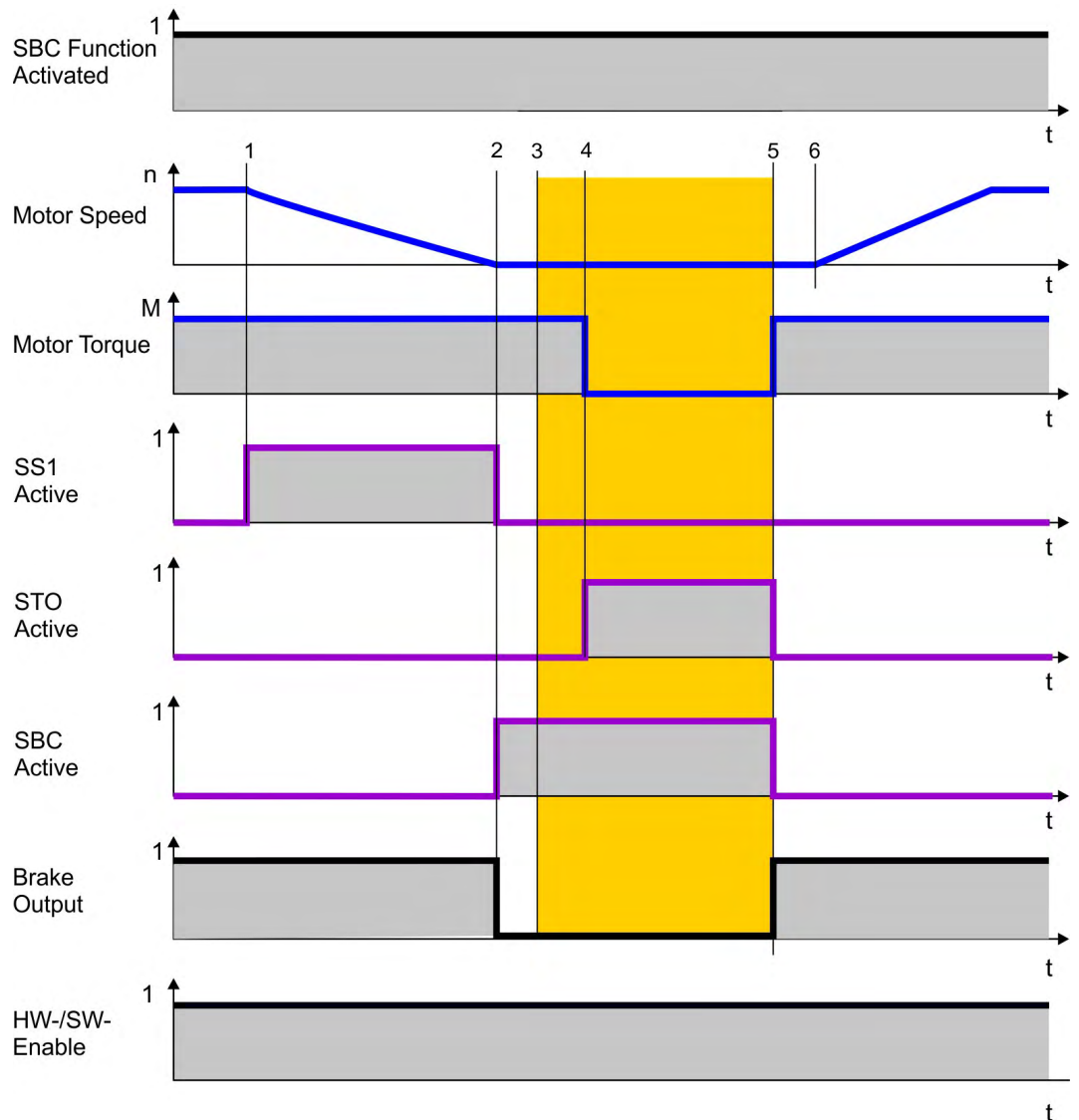

Timing	max	Remarks
t1		SS1 activate
t1 to t2	configurable	t _{SS1} : Time window for deceleration
t2		SBC activate. brake output 0V
t2 to t3	see brake datasheet	Brake engaging
t3		Brake is applied
t2 to t4	configurable	t _{SBC} : Brake time delay
t4		STO activate
t5		STO, SBC deactivate, Brake output 24V
t5 to t6	see brake datasheet	Brake disengaging
t6		Brake is released

10.3.5.8 Timing, SS1 followed by SBC with SDB

SBC is configured “with SDB”: when STO is requested (STO becomes active), the brake output and the STO output are deactivated at the same time.

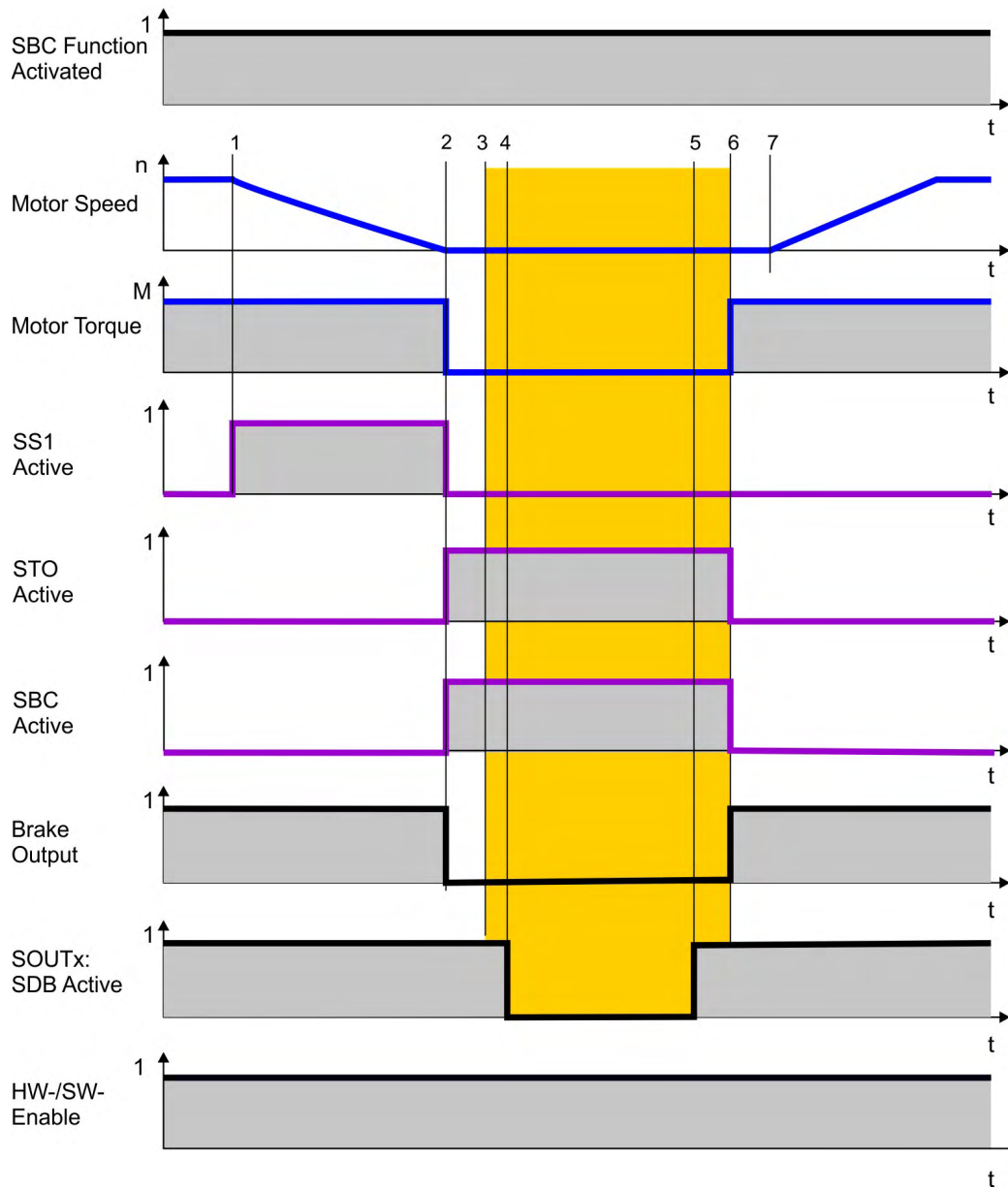

Timing	max	Remarks
t1		SS1 activate
t1 to t2	configurable	t _{SS1} : Time window for deceleration
t2		SBC activate. Brake output 0V
t2 to t3	see brake datasheet	Brake engaging
t3		Brake is applied
t2 to t4	configurable	t _{SDB} : Delay before switching
t5		SDB active. SOUTx active
t5 to t6	configurable	t _{SDB} : Delay before switching
t6		STO and SBC deactivates
t6 to t7	see brake datasheet	Brake disengaging
t7		Brake is released

Note: t_{SBC} is not used in case SDB is configured.

10.3.5.9 Setup in Workbench

Select Safety Parameterization view (→ # 193). Choose the axis (1), category (2) and SBC function (3). The instance number (4) is not applicable for SBC.

Parameters Editor [Learn more about this topic](#)

Configuration of the safety parameters.

Axes	Categories	Safe Stop	Instances
Common	General	STO (Safe Torque Off)	Instance 1
Axis 1	Safe Stop	SS1 (Safe Stop 1)	
Axis 2		SBC (Safe Brake Control)	
		SBT (Safe Brake Test)	
		SDB (Safe Dynamic Brake)	

[Goto Safety Parameter Download](#)

[SafeID: 1] Axis 1 > Safe Stop > SBC (Safe Brake Control) > Instance 1

Type: **Kollmorgen AKD2G SMM**
 Description: **Kollmorgen AKD2G SafeMotion Monitor**
 Import file: -

Parameter	Value	Unit
Axis 1 - Safe Stop - SBC - Instance 1		
SBC Brake 1	Configured without SDB	
SBC Brake 2	Configured with SDB	
Brake Time Delay (TSBC)	100	ms
SBC Muting	Not Used	

Validation Results (0)

Device Related Parameters (3)

Brake 1 used by: (5)

Brake 2 used by: (6)

Axis 1 Brake(s): (7)

Each brake needs to be assigned to its controlling axis with the device related parameters: Assigne the axis for Brake 1 (5), assigne the axis for Brake2 (6). (7) indicates whether the drive has detected a brake for the corresponding axis.

NOTICE

The device related parameter settings are not safe. Changing the configuration in this view will affect the device related parameters.

If the configuration collides with the safe settings, warning 9007 will be issued when the axis is disabled. Enabling the affected axis will be prohibited in this case.

On single axis drives, axis 1 can be configured to control brake 1 and 2 with SBC. For dual axis drives, the brake configuration must be considered:

Assignment	Axis#	Brake1	Brake2	Comment
Example 1	Axis1	SBC	SBC	If both brakes are assigned to axis1, axis2 cannot control any of those two brakes.
	Axis2	-	-	
Example 2	Axis1	SBC	-	If axis1 controls brake1 with SBC, axis2 can control brake2 with SBC.
	Axis2	-	SBC	
Example 3	Axis1	-	-	If both brakes are assigned to axis2, only brake2 can be controlled with SBC. Brake1 will be controlled, but not safe (no SBC).
	Axis2	no SBC	SBC	

10.3.5.10 Fault Reaction/ Failure Messages

It is not possible to detect a malfunctioning brake through SBC. Therefore diagnosis with SBT is necessary in regular time intervals (see (SBT (Safe Brake Test), → # 179)).

A disconnected brake or an open circuit on the brake connectors (X1, X2 or X4) will result in an I/O failure causing SS1_1 (fault reaction) to be triggered followed by STO.

An I/O failure warning is issued when the AKD2G is disabled.

A fault will be issued when the AKD2G is enabled and [AXIS#.SAFE.STO.REPORTFAULT](#) is set to 1.

10.3.5.11 Safety State/ Status signals

For brake status see diagnostic results of SBT Fault Reaction. The WorkBench view “Diagnostics” shows the current status of the SMM. I/O failures caused by the brakes will be shown on “Current Error”.

10.3.5.12 Safety Properties

Refer to (Safety properties overview, → # 150).

10.3.6 SBT (Safe Brake Test)

Safe Brake Test description for drive option Functional Safety 2 or 3.

10.3.6.1 Description

The function SBT (Safe Brake Test) can be used for testing the brakes connected to X1, X2 or X4 of the AKD2G. SBT is carried out by applying a configured torque against the closed brake and supervising the axis motion. The test is successful if the axis motion does not exceed a parameterized tolerance. If the axis motion exceeds the tolerance, the test is failed and therefore the safety functions using the brake are lost. After a failed brake test, safe brake operation cannot be assumed anymore. Brake replacement or service will be necessary.

- SBT is a diagnostic function for holding brakes. In order to operate brakes (SBC) that are part of a safety function (PLd / SIL2 or higher), frequent tests with SBT are required.
- SBT must be triggered regularly by the end customer.
- SBT considers the derating factor for brakes used in safety functions.
- During SBT, 130% of the max. possible application torque will be applied to the brake. Additional forces caused by vertical loads will be taken into account automatically.
- Brake slippage will be detected with a resolution of at least 1°.
- Two brakes can be assigned to one axis. Each brake can be configured with an independent slippage tolerance.
- SBT is only functional if SBC is used as well.
- SBT does not cause wear out to the brakes.

Important Notes

NOTICE

- The user (end customer) is responsible for the execution of the SBT.
- For correct operation of SBT, the axis must be free to move when the drive releases the brake or releases both brakes as appropriate; if the machine has further motors and/or brakes mechanically coupled to the same axis, then these further devices must be placed in states where they do not impede motion before SBT is carried out. In this case only one brake shall be tested at a time. Each brake must be tested independently.

A brake test must be executed

- at least every 8 hours,
- at the start of a machine or at the transition to operation mode using the brake,
- after long standstill of the machine,
- after drive reboot,
- after brake service or replacement.

Depending on the target SIL / PL of the safety function that is performed by the brakes, it can be necessary to carry out SBT more often. In high safety demand applications (SIL3 / PLe, DC = high), it can be necessary to execute SBT every time prior to demand. For example if access to a dangerous area is prohibited by a safety interlock, SBT must be executed successfully before access can be granted.

Restrictions

The maximum motion for the brake during safe brake test (see “Maximum Motion” parameters (Related Parameters, → # 181)) cannot be set to a greater or equal value than 10800 arcminute. Otherwise, the SMM will return an error code once SBT function is started. The error code can be read by the keyword [AXIS#.SAFE.SBT.ERROR](#), which will report “0x6 – SMM System Error”.

In general, it is expected to set the maximum motion for the “tested” brake as small as possible to prevent any mechanical hazards when the brake loses its holding function. However, an application might need a larger tolerance window because of a mechanical gearing between encoder and motor shaft. To detect a brake slippage properly, the user shall make sure that the actual velocity measured by the encoder is smaller than a maximum slippage velocity.

The maximum slippage velocity in [RPM] is calculated by:

$$(10800 [\text{arcmin}] - \text{“Max. Motion”} [\text{arcmin}]) * 600 / 216$$

Example:

- For “Max. Motion” = 300 arcmin (5°), the max. slippage velocity is $(10800-300) * 600/216 = 29167$ rpm.
- For “Max. Motion” = 7200 arcmin (120°), the max. slippage velocity is $(10800-7200) * 600/216 = 10000$ rpm.

NOTE

The user has to consider for his application the worst case max. acceleration of motor shafts load including the additional "applied" test torque of the drive during SBT.

Preconditions in order to start a brake test

- the motor is at standstill, the tested brake is released.
- the drive is enabled, STO is not active,

It is up to the machine manufacturer to determine the SIL / PL reached by SBC + SBT according to the configuration and parameterization.

Encoder requirements

The SBT function can be executed with any encoder type. However, the encoder shall have at least a resolution and accuracy of 1 degree.

Encoder verification:

The user shall verify that the encoder works properly by his application. As example the following types of machine motion can be used to verify the function of the encoder:

- Perform a home move which includes a physical motion.
- A position move of at least 1 mechanical revolution of the encoder.
- A relative move to reach the start position of SBT.

After a long downtime of the machine, the encoder verification shall be repeated.

Current measurement verification

The verification check of drive current measurement should be done during machine commissioning and during re-commissioning due to changes such as replacement of the drive or firmware update.

The current measurement should verify expected current reported by the drive when holding a reference load. A small movement may be needed to overcome static friction.

Function Input/Output variables**Inputs**

- **SBT Activate** can be activated by
 - EtherCAT, CANopen
 - Digital input (must be mapped)
 - WorkBench

Outputs

- **SBA State**: logical status providing information on SBT. Can be mapped to a safe output and retrieved through FSoE status word.
 - 0 = SBT execution necessary or failed in last attempt.
 - 1 = SBT was executed successful within the parameterized period
- **SBT State**: status information on the actual brake condition
 - 0 = No Fault
 - 1 = Fault
 - 2 = Not Tested
 - 3 = Running

Number of instances

One instance per axis.

10.3.6.2 Activation

- By a non safe fieldbus: EtherCAT or CANopen SDO
- By a non safe digital input (DIGITAL-IN1 to DIGITAL-IN12, (→ # 116)).
- By Workbench

10.3.6.3 Related Parameters**Safety Parameters**

Name	Variables	Default	Parameter
Function Activation	-	-	(→ # 239)
Maximum Time Interval	-	480 min	(→ # 241)
Max Application Load	-	1000 mA	(→ # 239)
Maximum Motion 1st Attached Brake	-	300 arcmin	(→ # 240)
Maximum Motion 2nd Attached Brake	-	300 arcmin	(→ # 240)
Torque Duration	-	500 ms	(→ # 241)

Diagnostic Parameters

Name	Variables	Default	Parameter
SBT Actual Status	-	-	(→ # 230)
SBT Move		-	(→ # 229)
SBT SBA Active		-	(→ # 229)
SBT Error		-	(→ # 228)
Brake SBT Elapsed		-	(→ # 250)
Brake SBT State		-	(→ # 251)

10.3.6.4 Timing

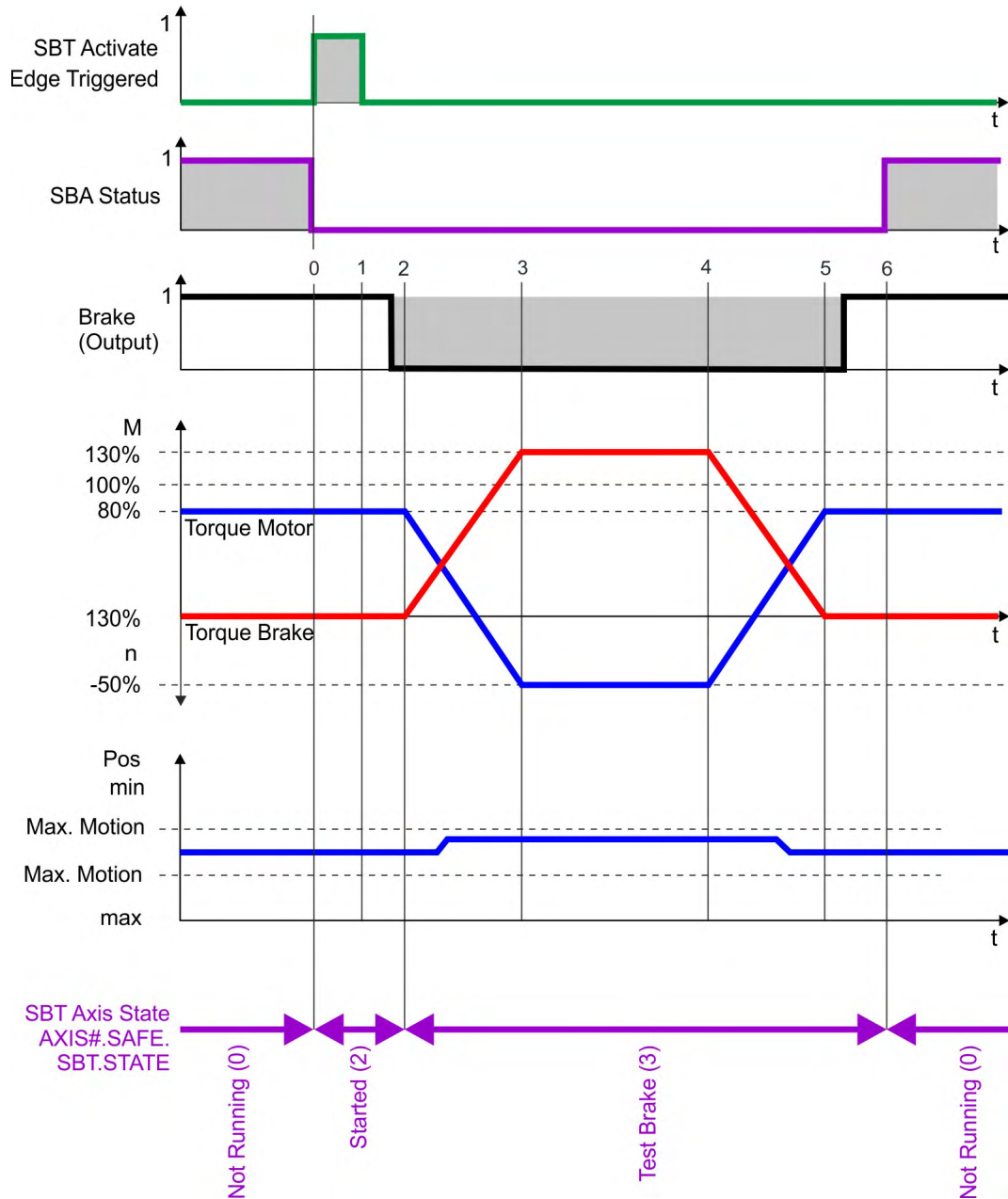

Timing	max	Remarks
t0		Start SBT
t0 to t1	200 ms	Measuring actual application load on motor
t1 to t2	300 ms	Brake engaging
t2		Brake is applied. Position monitoring is started. Drive is switched to torque mode internally.
t2 to t3	$1/3 * (t3 \text{ to } t4)$	Ramp-up to apply 130% torque on the brake
t3 to t4	Configurable	Torque duration
t4 to t5	$1/3 * (t3 \text{ to } t4)$	Ramp-down torque on the brake
t5 to t6	300 ms	Release brake
t6 to t0	Configurable	Maximum time interval between tests

10.3.6.5 Setup in Workbench

Select Safety Parameterization view (→ # 193).

Choose the axis (1), category (2) and SBT function (3). The instance number (4) is not applicable for SBT.

Parameters Editor [Learn more about this topic](#)

Configuration of the safety parameters.

Common	Categories	Safe Stop	Instances
Axis 1	General	STO (Safe Torque Off)	Instance 1
Axis 2	Safe Stop	SS1 (Safe Stop 1)	
		SBC (Safe Brake Control)	
		SBT (Safe Brake Test)	
		SDB (Safe Dynamic Brake)	

[Goto Safety Parameter Download](#)

[SafeID: 1] Axis 1 > Safe Stop > SBT (Safe Brake Test) > Instance 1

Type: **Kollmorgen AKD2G SMM**
 Description: **Kollmorgen AKD2G SafeMotion Monitor**
 Import file: -

Parameter	Value	Unit
Axis 1 - Safe Stop - SBT - Instance 1		
Function Activation	Ready for Activation	
Maximum Time Interval	480	minute
Max Application Load	1000	mA
Maximum Motion Brake 1	300	arcmin
Maximum Motion Brake 2	300	arcmin
Torque Duration	500	ms

10.3.6.6 Fault Reaction/ Failure Messages

If not all the preconditions are fulfilled and SBT is requested, the SBT diagnostics will show a Brake Test Error:

(B) Safe Brake Test
 Safe brake test activation and monitoring.

Axis 1

Brake Test Enabled: 1 - Ready for Activation Start Brake Test

Max Time Between Test: 00:01:00 hh:mm:ss

Brake Test State: 0 - Not running

Brake Test Error: 0 - No error

After a brake fails SBT, the axis where the brake is attached to will not be operational anymore. SBA will remain 0 and the Safety Diagnostics will show a "Brake Slippage Occurred":

Axis 2

Brake Test Enabled: 1 - Ready for Activation Start Brake Test

Max Time Between Test: 00:01:00 hh:mm:ss

Brake Test State: 0 - Not running

Brake Test Error: 6 - Brake slippage occurred

When brake slippage is detected during the brake test, a controlled stop will be executed immediately. The drive remains enabled.

10.3.6.7 Safety State/ Status signals

Status of each axis and the assigned brakes can be observed in the SBT diagnostics view.

B

Safe Brake Test

Safe brake test activation and monitoring.

Axis 1

Brake Test Enabled: 1 - Ready for Activation Start Brake Test

Max Time Between Test: 00:10:00 hh:mm:ss

Brake Test State: 0 - Not running

Brake Test Error: 0 - No error

Brake 1

State: 0 - Not tested

Time Remaining Until Next Check: 00:09:39 hh:mm:ss

The view gives information about:

- Status, whether the test is running or not
- Test result (Not tested, Failed, Passed)
- Timings till next and in in-between test
- Status information in the test: if errors occurred

If a brake test is not executed within the parameterized time interval, the Safe Brake Test Diagnostics will inform that the Test validity is expired.

Time Remaining Until Next Check: 00:00:00 hh:mm:ss ⚠ Test validity expired!

The warning 9008 “Brake Test Time Overflow” will be issued alongside STO.

Axis (1): ✖ 1 Fault(s) ⚠ 1 Warning(s)

Disable & Clear Faults

✖

Axis	Type	Group	Id	Description	Details
1	✖	Safety	9000	Safe torque off.	Help
1	⚠	Safety	9008	Warning: Brake Test Time Overflow.	Help

Disable Fault auto popup.
 Disable Warning auto popup.

Copy

10.3.7 SDB (Safe Dynamic Brake)

Safe Dynamic Brake description for drive option Functional Safety 2 or 3.

10.3.7.1 Description

If the motor brake allows standstill braking only, dynamic braking is a method to slow down a servo system by dissipating the mechanical energy driven by the motor back EMF. When activated, the optional external Safe Dynamic Brake Module (SDB-Module) shorts the motor terminals. This forces all of the dynamic braking current to be stopping current. While the lines to the motor are shorted, the SDB status signal will be applied. When configured, SDB gets executed simultaneously along with STO.

Use this function when operating in Torque Mode and with high inertia loads.

Important Notes



WARNING No Brake Power at and near standstill!

Serious injury could result when the load is not properly blocked. This function does not ensure functional safety.

- Add a safe mechanical blocking (for instance, a motor holding brake).
- Configure (SBC (Safe Brake Control), → # 171) to be used with SDB.

NOTICE

- It is not possible to perform a controlled brake according to IEC 60204-1 category 1, if SDB function is active. If controlled braking category 1 is necessary, SS1-t function should be used.
- A failure in the SDB-Module can only be detected when changing states. In order to detect a loss of the safety function, SDB (STO) needs to be activated regularly according on the SIL/PL.
- The SDB-Module is a safety related electromechanical component. The frequency of use contributes to its PFHd value and therefore to the whole safety chain.
- Activating the SDB-Module (0V, closing contacts) will result in a short circuit on the output stage which could impair the drive when enabled. Therefore pay close attention to the parameterized timings especially during restart. Keep in mind the mechanical reaction time of the SDB-Module for both directions.
- Brake power depends on the inertia and speed of the decelerated mass. Activating SDB when the motion contains, high amounts of energy can result in a very fast stop. The braking energy and therefore the braking speed can be limited using external resistors.
- For assistance with determining stopping time and braking current when using the SDB function of the AKD2G refer to the online [AKD2G Safe Dynamic Braking Tool](#) or contact Kollmorgen technical support.

Function Input/Output variables



Inputs

- **STO Active:** refer to (STO (Safe Torque Off), → # 162)
- **SDB Readback:** input for diagnosis signal returning from the SDB-Module

Outputs

- **SDB Activate:** signal for activating the SDB-Module

Number of instances

One instance per axis.

10.3.7.3 Restart

Refer to STO for restart conditions (Restart, → # 163). When all conditions for a STO restart are fulfilled and SDB is configured, the SDB-Module will be deactivated and the readback diagnosis will be disabled. After the configured delay (same as during SDB activation) the STO will disable, allowing torque. The readback diagnosis will reengage after the configured time.

10.3.7.4 Timing

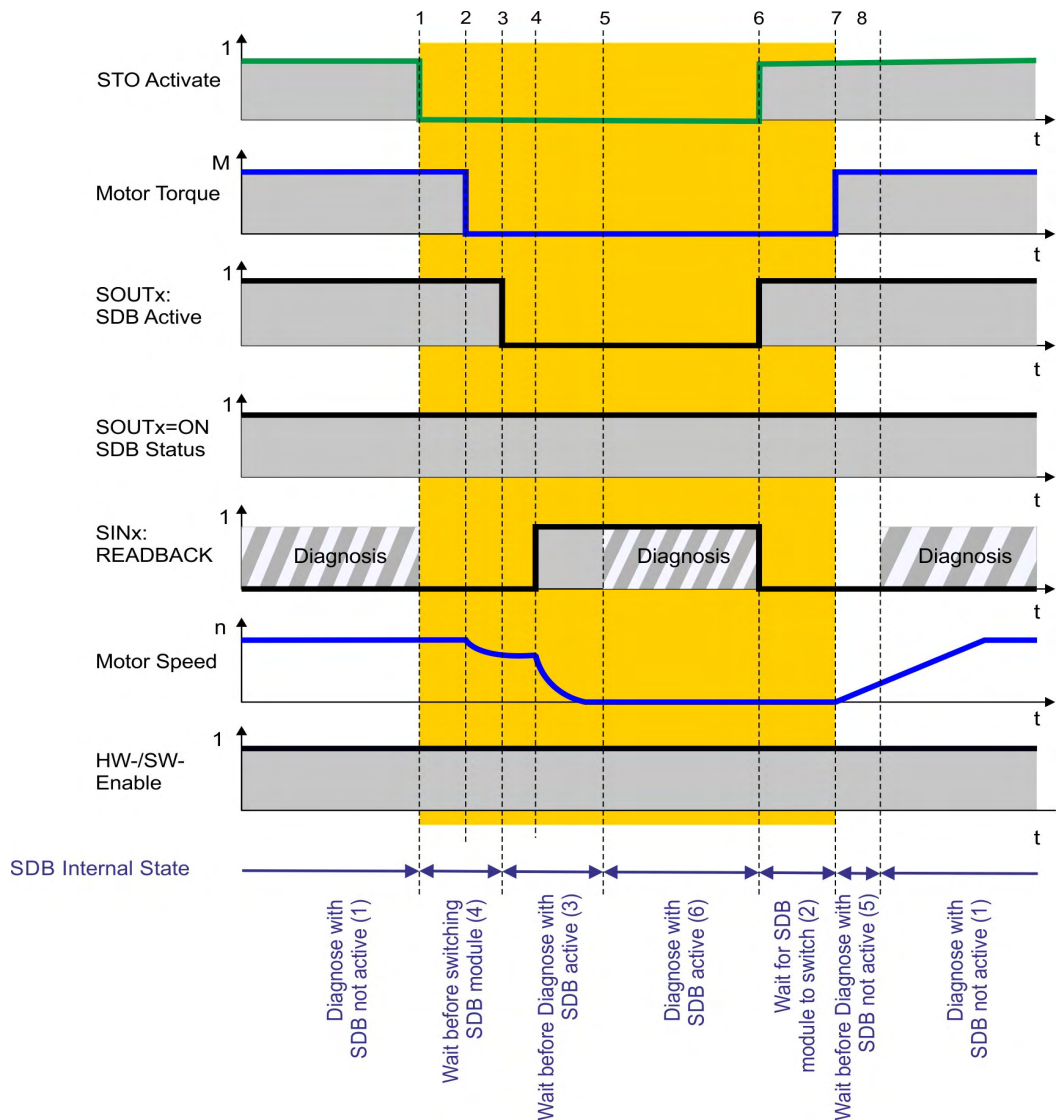

Timing	max	Remarks
t1 to t2	< 6 ms	STO response time
t1 to t3	configurable	tSDB: Delay before switching SDB module
t3 to t4	see datasheet	Mechanical delay SDB module
t3 to t5	configurable	t _{D_SDB} : Delay until readback diagnosis
t6 to t7	configurable	tSDB: Maximum delay for SDB Module to switch
t6 to t8	configurable	t _{D_SDB} : Delay until readback diagnosis.

10.3.7.5 Related Parameters

Name	Variables	Default	Parameter
Function Activation	-	0	(→ # 243)
Readback	-	Not Used	(→ # 243)
Delay Before Switching	tSDB	1 ms	(→ # 242)
Delay Before Diagnose	t_D_SDB	1 ms	(→ # 242)

10.3.7.6 Setup in Workbench

Select Safety Parameterization view (→ # 193).

Choose the axis (1), category (2), SDB function (3) and the instance number (4).

Parameters Editor [Learn more about this topic](#)

Configuration of the safety parameters.

Axes	Categories	Safe Stop	Instances
Common Axis 1 Axis 2	General Safe Stop	STO (Safe Torque Off) SS1 (Safe Stop 1) SBC (Brake Control) SBT (Brake Test) SDB (Safe Dynamic Brake)	Instance 1

[Goto Safety Parameter Download](#)

[SafeID: 1] Axis 1 > Safe Stop > SDB (Safe Dynamic Brake) > Instance 1

Type: **Kollmorgen AKD2G SMM**
 Description: **Kollmorgen AKD2G SafeMotion Monitor**
 Import file: -

Parameter	Value	Unit
Axis 1 - Safe Stop - SDB - Instance 1		
Function Activation	Ready for Activation	
Readback	Safe input 3 (SIN3)	
Delay Before Switching (tSDB)	1	ms
Delay Before Diagnose (t_D_SDB)	1	ms

10.3.7.7 Fault Reaction/ Failure Messages

The drive supervises the safe input(s) assigned as readback. An OSSD pulsed signal (either from a safe output or a safe PLC) is expected. When the readback signal becomes static, an I/O error will be detected.

During the activation and deactivation of the SDB-Module, the readback diagnosis will be interrupted for the parameterized amount of time. When STO/SDB are active, a high signal (24V) is expected. When STO/SDB are not active, a low signal (0V) is expected. Deviating this expected behavior will additionally result in a SDB failure recognizable from the diagnostics view.

Diagnostics
 Current status and configuration of the safe module monitor.

Identification / Validation

Safe ID:

System CRC:

Current State

System State:

Current Error:

For detailed information on the signal states refer to (→ # 187).

10.3.7.8 Safety State/ Status signals

The WorkBench view “Safety Diagnostics – Safe I/O” shows the current status of the safe inputs and outputs.

The target status can be read of the assigned output(s). The status of the SDB readback can be read from the assigned input(s). Which state is appropriate depends on the system state.

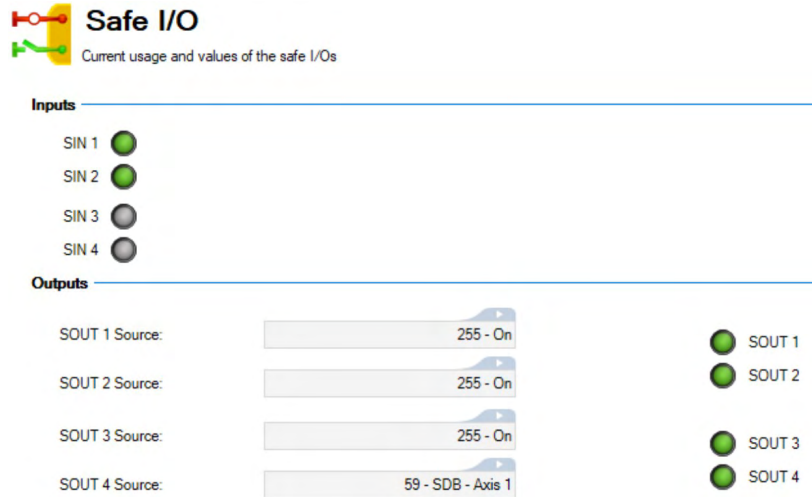

For detailed information on the signal states refer to (→ # 187).

10.3.7.9 Safety Properties

Refer to (Safety properties overview, → # 150).

10.4 Settings

10.4.1 Display, Push-Buttons and Rotary Switches

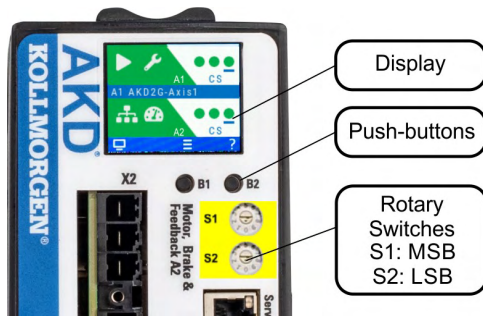

Display (example for a dual-axis module)

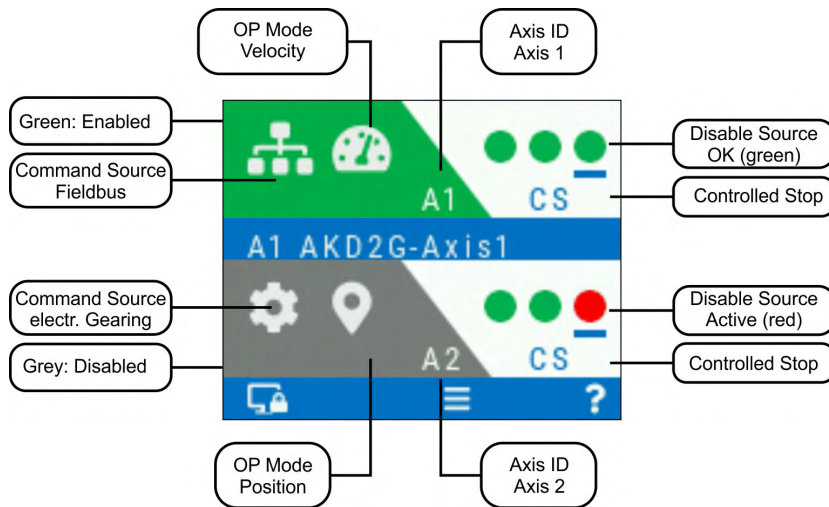

Push-buttons (B1, B2)

A short button press invokes the action corresponding to the symbol directly above the button. On the dashboard for example,

- a short press on B1 causes the menu system to appear, and
- a short press on B2 causes a help screen to appear.
- A long press (greater than 2 seconds) on B2 returns the display to the previous screen.

B1 / B2 Functions	Description
Boot from SD card	Push both buttons during power up to boot with data from SD card. Press the buttons first, then hold it down while turning on the 24 V power supply.
Boot from flash fallback image	Remove the SD card, then press both buttons and hold them down while turning on the 24 V power supply to boot from an on-board recovery image.
SafeID Validation	Push B2 to acknowledge SafeID validation request on the display.

Rotary Switches (S1, S2)

Two decimal coded rotary switches are used to set a unique SafeID for the drive module. S1 sets the ten place, S2 sets the one place.

Process:

1. Switch off 24V supply voltage.
2. Set S1 and S2 to a unique SafeID.
3. Switch on the 24V supply voltage.

10.4.2 Default safety parameters

Default device parameters

The AKD2G will be shipped to customer pre-programmed. The SafeID will be set to 1 and a set of parameters will be downloaded in the non-volatile memory of the SMM. When these parameters are cleared or when the SafeID is changed, this parameter set is lost and cannot be retrieved. The drive is ready to operate with pre-configured STO function.

WorkBench Safety default parameters

These are the parameters presented by default when adding a new safety device to a safety project. The SafeID is set to 1 by default. The user can change some of these parameters, all of them or none of them.

FSoE parametrization: default parameters

Safety parameters can be downloaded through EtherCAT SDO (→ # 201) and then validated through FSoE using the SRA CRC ([AXISx.SAFE.FSOE.SRACRC](#)). By default, parameters will be downloaded with their default values found in the ESI file (default values in the ESI corresponds to the default values used by WorkBench Safety).

To use FSoE parametrization, the user must clear the parameters from the non-volatile memory. The user can keep the default configuration from the ESI file by just using the default SRA CRC (found in the ESI file). The “FSoE parameters” are stored in the volatile memory only and they will be invalidated after a reboot or a restart of the FSoE stack.

10.4.3 SafeID

NOTICE

If you set a functional safety system, you have the responsibility to ensure, that

- every AKD2G has a distinct SafeID,
- every device on the safe fieldbus has a unique FSoE address,
- the SafeID is adjusted to the application during commissioning (→ # 147),
- the SafeID is validated to the application (→ # 205).

Restarting the drive after changing the SafeID will result in the loss of this default configuration and will cause a non-operational state as long as no other parameter package is downloaded and validated.

Restarting the drive after changing the SafeID in general will invalidate the current safety configuration. Returning the SafeID to the previously configured value afterwards will not revalidate the previously used configuration. In order to use this or another configuration again, a new download and validation of a parameter package is necessary.

NOTE

The SafeID value 00 will also invalidate/clear the safety configuration after a restart but cannot be used as regular value for operation.

The SafeID is calculated based on the rotary switches setting:

$$\text{SafeID} = 10 \cdot S1 + S2$$

Example:

$$\text{Rotary switches: } S1 = 2, S2 = 3 \rightarrow \text{SafeID} = 10 \cdot 2 + 3 = 23$$

Press the button B1 on the front of the drive or read the parameter [SAFE.ID](#) to check the ID.

Default: When shipped, the SafeID is preset to 01 by default (SafeID = 1). The default safety configuration is bound to this SafeID.

10.4.4 FSoE Node Address

The unique FSoE address for every axis is derived from the set SafeID.

Axis	FSoE address	Minimum FSoE Address	Maximum FSoE Address
1	SafeID • 100 + 1	101	9901
2	SafeID • 100 + 2	102	9902

Example for FSoE address setting:

Rotary switches setting: S1 = 2, S2 = 3 → SafeID = $10 \cdot 2 + 3 = 23$

Resulting FSoE address for axis 1 : $23 \cdot 100 + 1 = 2301$

Resulting FSoE address for axis 2 : $23 \cdot 100 + 2 = 2302$

Default: With default SafeID setting (01) the resulting FSoE addresses are 1001 / 1002.

10.4.5 Instances

Many safety functions offer several instances. An instance is an independent, separately selectable and configurable variant of the respective function. The activation source for each instance can be selected individually (safe digital input or FSoE).

Some instances are labeled "Fault Reaction". In case of an error detection or an internal malfunction, these instances will be executed by default.

NOTE

SS1 instance 1 and STO are the default fault reactions and cannot be deactivated. Configure these instances accordingly.

10.4.6 Workbench Safety Function Setup

In general, three steps need to be done to activate a safety configuration within the SMM:

1. Configuration of the safety parameters.
2. Download the safety parameters (→ # 200) to the drive through:
 - Workbench (Telnet): persistent, or
 - EtherCAT (FoE): persistent, or
 - EtherCAT (FSoE) : non persistent.
3. Validation of the safety parametrization by the user.

The diagram shows a possible scenario:

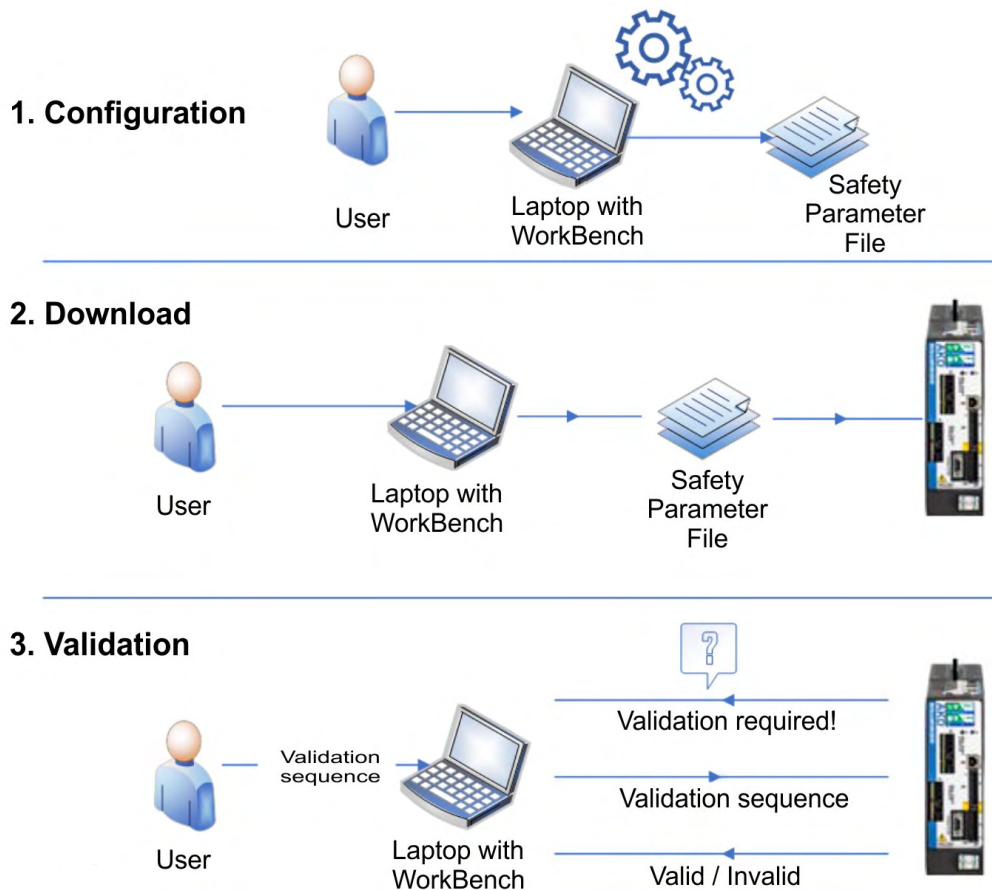

The safety parameter configuration can be easily done through KollmorgenWorkBench. The safety parameter configuration, download and validation are completely integrated.

WorkBench performs a consistency check which helps to identify contrary configurations. If the configuration passes the consistency check, WorkBench creates a safety parameter file. This file can be download to the drive through WorkBench or can be exported. Once the safety parameters are configured, downloaded and validated through WorkBench, the safety configuration will be persistent and no new configuration will be necessary after power cycle.

Preconditions

- AKD2G Service port X20 (→ # 110) is connected by using Ethernet cable to the computer or to a network switch.
- Auxiliary voltage is connected to AKD2G X10 and switched on.
- WorkBench setup software is installed.

10.4.6.1 Project building (online)

Offline project building is possible. In Step 4 you can select if you want to work online or offline.

1. Start WorkBench on the computer.

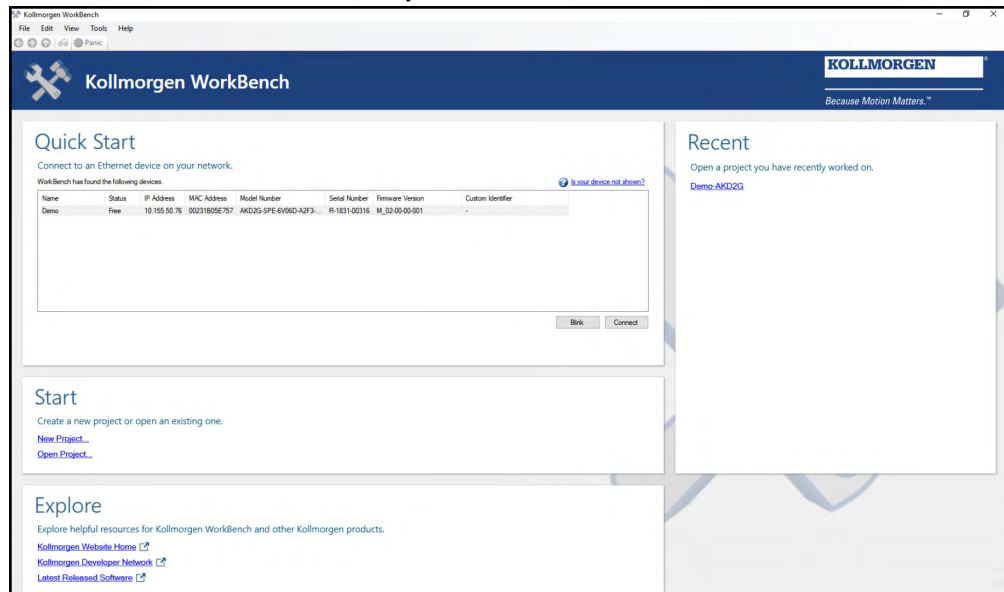

2. Create a new project.



3. Add a device to the project.

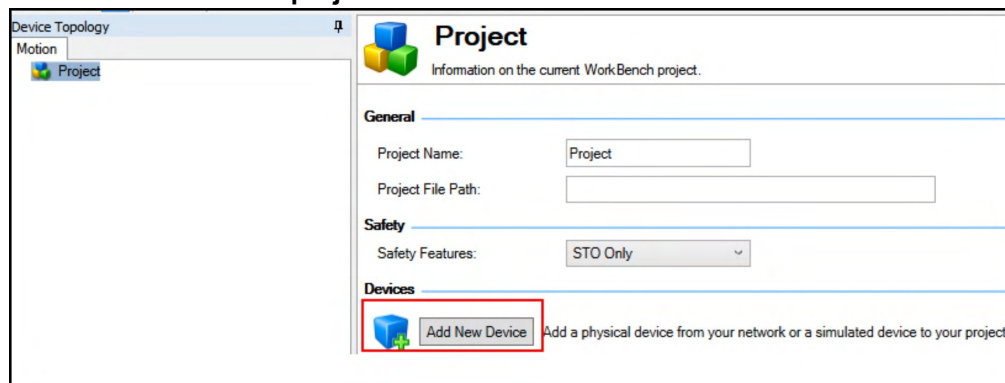

4. Select the device.

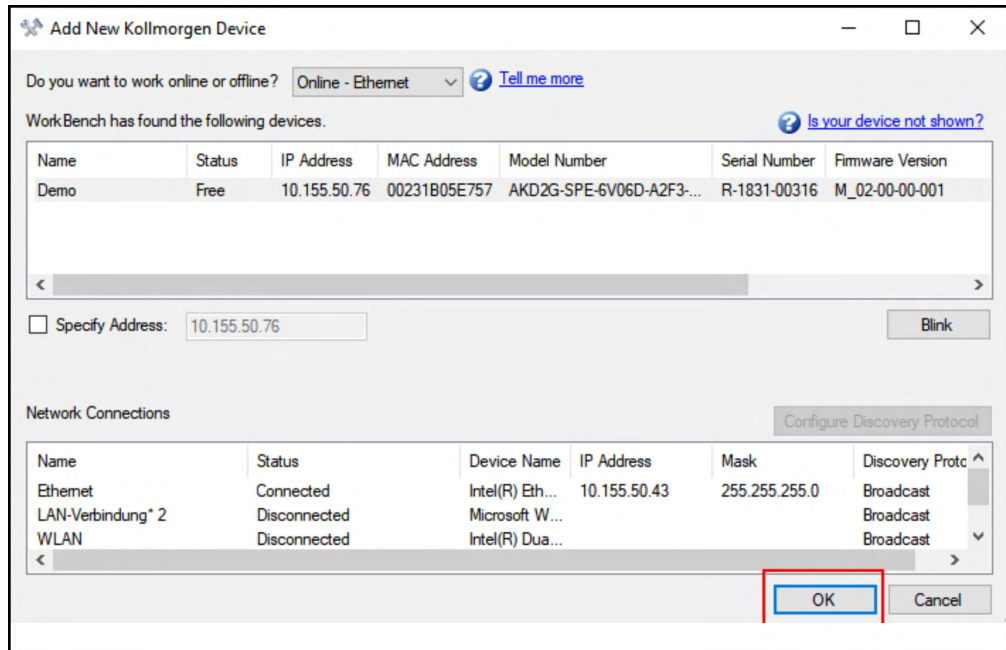

5. Select Safety Functionality

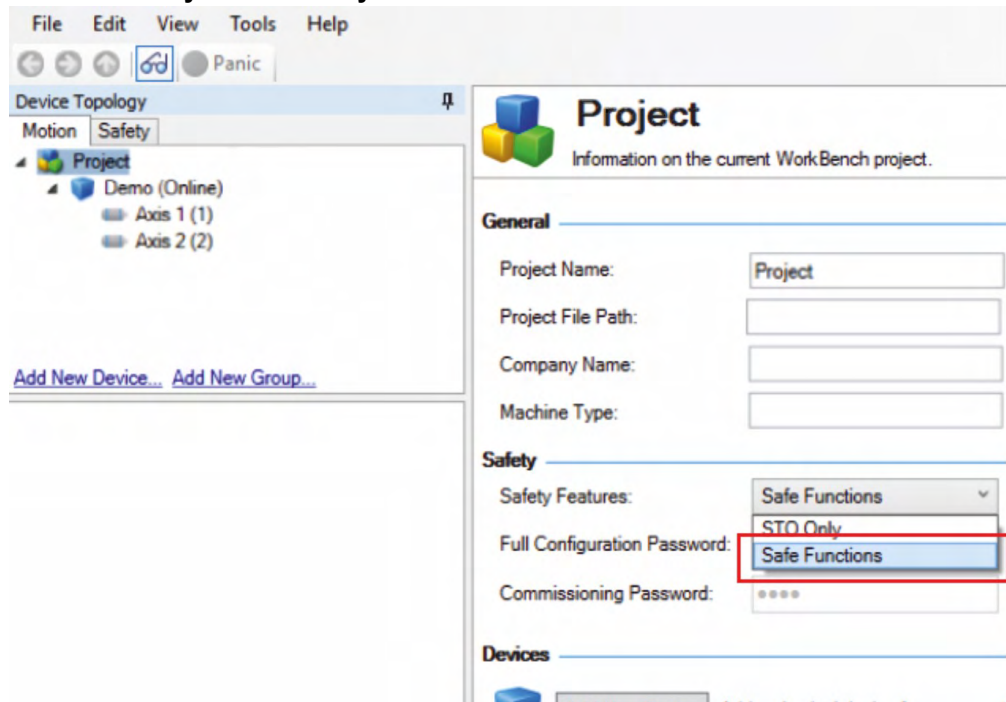

6. Set Password (example for full configuration)

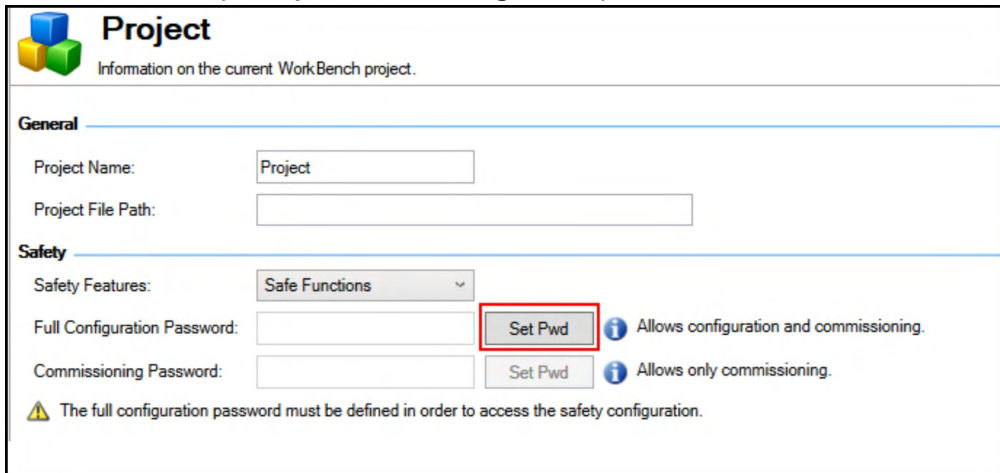

If you left the project and want to re-open it later, you need the password.

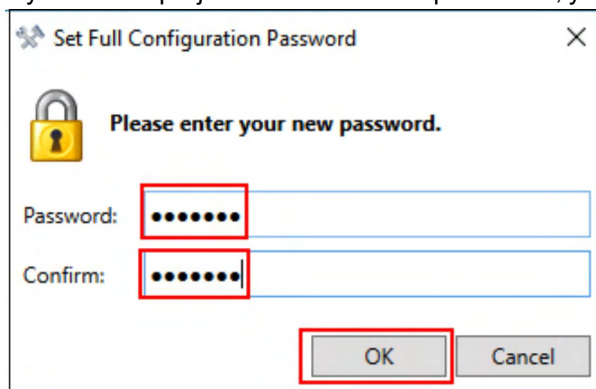

7. Save the project (Example: Demo-AKD2G)

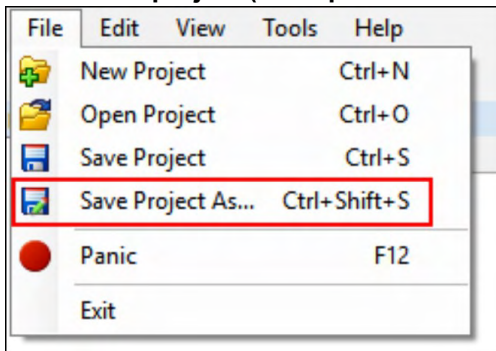

8. Select Safety.

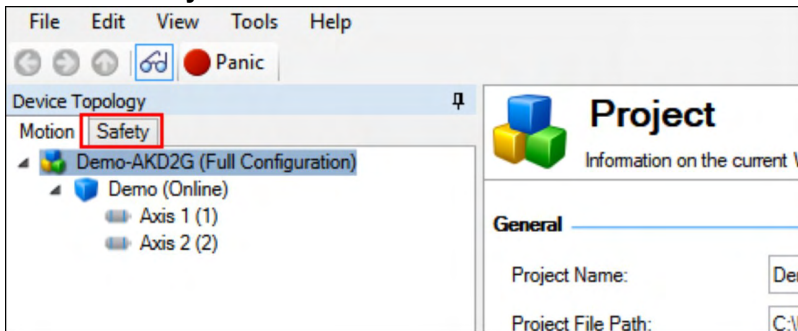

9. Select the Safety Group (rename if required) and add the device to the group.

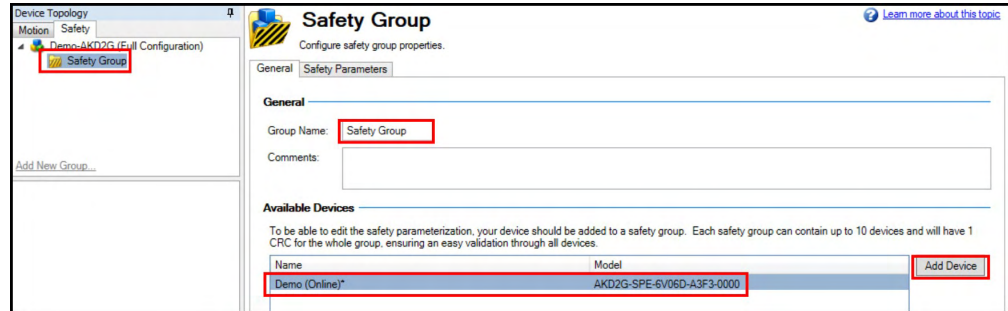

10. Select the Parameters Editor for parameterizing the safety functions.

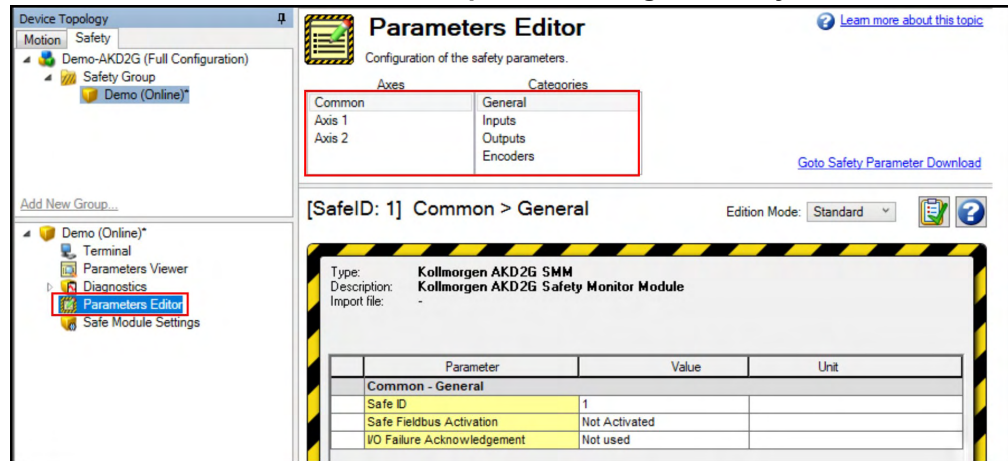

10.4.6.2 Parameters Editor

Common safety parameters

For general safety settings select "Common" and "General".

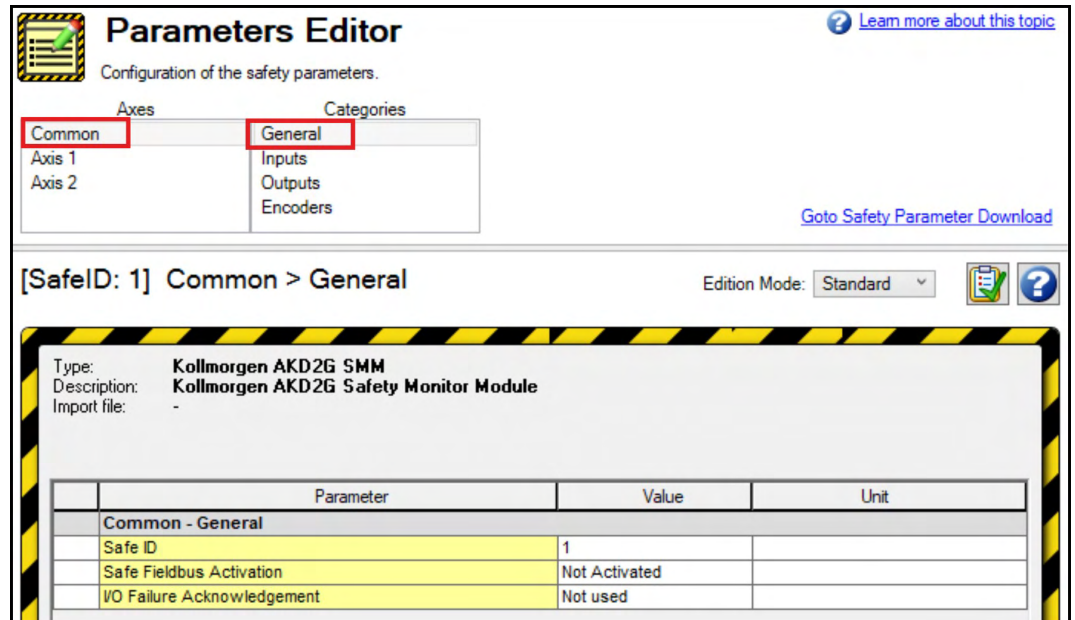

The SafeID (set with the rotary switches on the drive) is visible in the first line.

For safe input setting select "Common" and "Inputs"

Parameters Editor
Configuration of the safety parameters.

Learn more about this topic

Axes		Categories	
Common		General	
Axis 1		Inputs	
Axis 2		Outputs	
		Encoders	

Goto Safety Parameter Download

[SafeID: 1] Common > Inputs

Edition Mode: Standard

Type: **Kollmorgen AKD2G SMM**
Description: **Kollmorgen AKD2G Safety Monitor Module**
Import file: -

Parameter	Value	Unit
Common - Inputs		
Distinct Pulse Monitoring	Disabled	
SIN1DUAL Activation (SIN1/2)	Enabled	
SIN2DUAL Activation (SIN3/4)	Enabled	

Define the required behavior for OSSD test pulses (→ # 158). If you use dual channel inputs for a safety function, select the used safe input pair. For parameter description refer to (→ # 269).

For safe output setting select "Common" and "Outputs"

Parameters Editor
Configuration of the safety parameters.

Learn more about this topic

Axes		Categories	
Common		General	
Axis 1		Inputs	
Axis 2		Outputs	
		Encoders	

Goto Safety Parameter Download

[SafeID: 1] Common > Outputs

Edition Mode: Standard

Type: **Kollmorgen AKD2G SMM**
Description: **Kollmorgen AKD2G Safety Monitor Module**
Import file: -

Parameter	Value	Unit
Common - Outputs		
SOUT1DUAL Activation (SOUT1/2)	Disabled	
SOUT2DUAL Activation (SOUT3/4)	Disabled	
SOUT1DUAL Source	Off	
SOUT2DUAL Source	Off	
SOUT1 Source	On	
SOUT2 Source	On	
SOUT3 Source	Off	
SOUT4 Source	On	

If you need dual channel outputs for a status message, select the used safe output pair. For parameter description refer to (→ # 269).

Axis safety parameters

Choose the axis (1), select category (2), safety function (3) and instance number (4) .

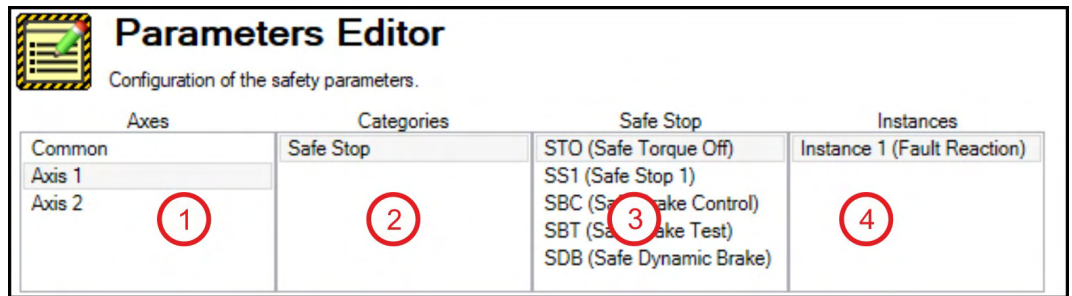

Parameterization see description of the specific safety function (→ # 149) . For parameter description refer to (→ # 214).

Define a parameterization package

When all parameters for all safety functions and for all devices are set, you can finish the parameterization. You must define a parameter bundle called "Parameterization Package".

Make sure you are on the device topology "Safety", click on your Safety Group name, and then on the "Safety Parameters" tab at the top. Then click on "new package" button.

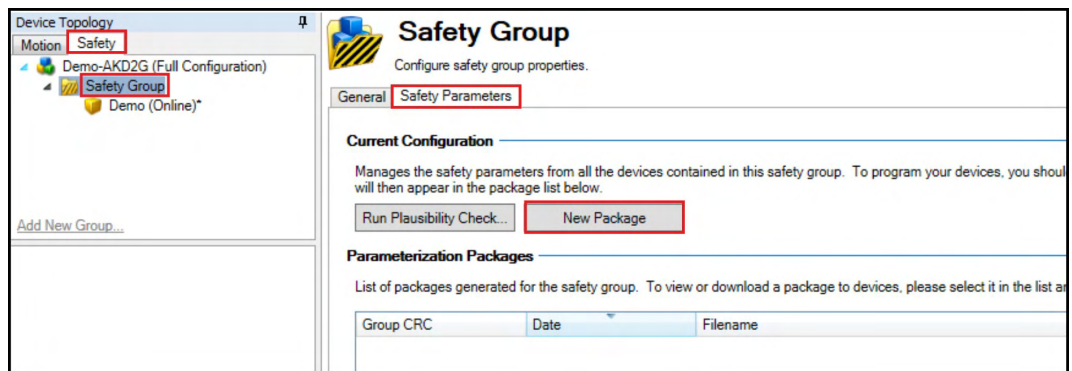

The safety parameters are bundled to a package in the "Parameterization Packages" screen.

View / Export / Delete a parameterization package

To see the contents of a parameter package, select the according package (1), click on the arrow next to "View" (2) and select "View Parameter Report" (3).

To save a parameter package externally click on "Export" (4).

To delete this package, click on "Delete" (4).

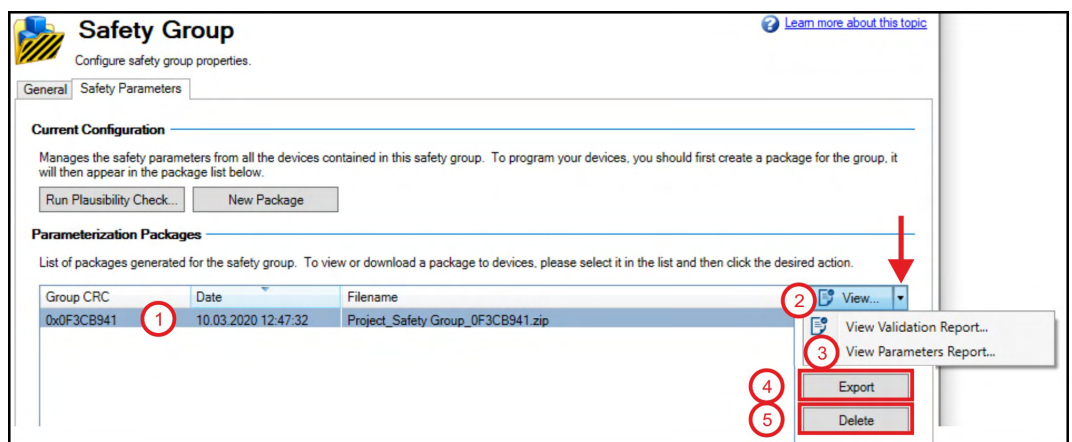

10.4.6.3 Safety Parameter Download

Download through WorkBench

Make sure you are on the device topology “Safety”, click on your Safety Group name, and then on the "Safety Parameters" tab at the top. Highlight the package that you want to send to the drive. Click on Download.

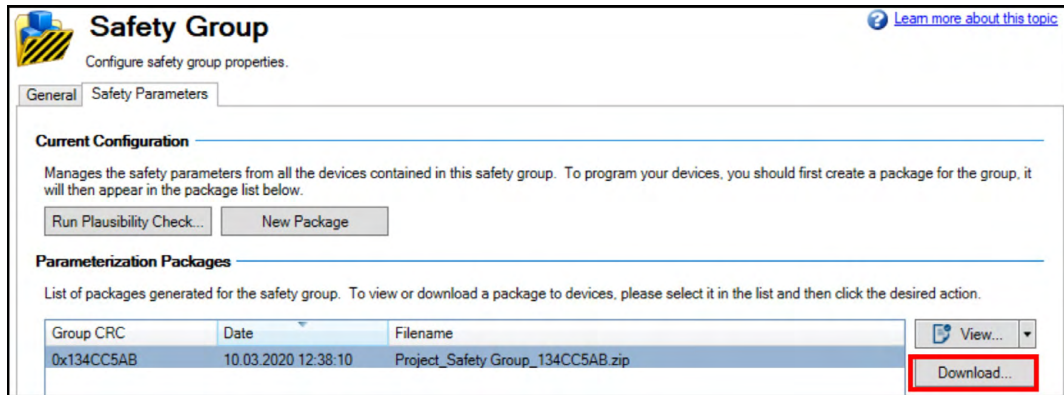

When safety parameter download to the AKD2G is selected, a validation and verification process starts before any parameter is written to the drive's memory. You are asked for a user name (1 to 8 characters) and a password (8 to 25 characters) to validate the package. Default password is “SafeMotionMonitor xyz” (“xyz” are the last three digits from the drive serial number, check serial numbers in the terminal with DRV.INFO, or name plate). Click on “Download” to transmit the parameter package to the drive memory.

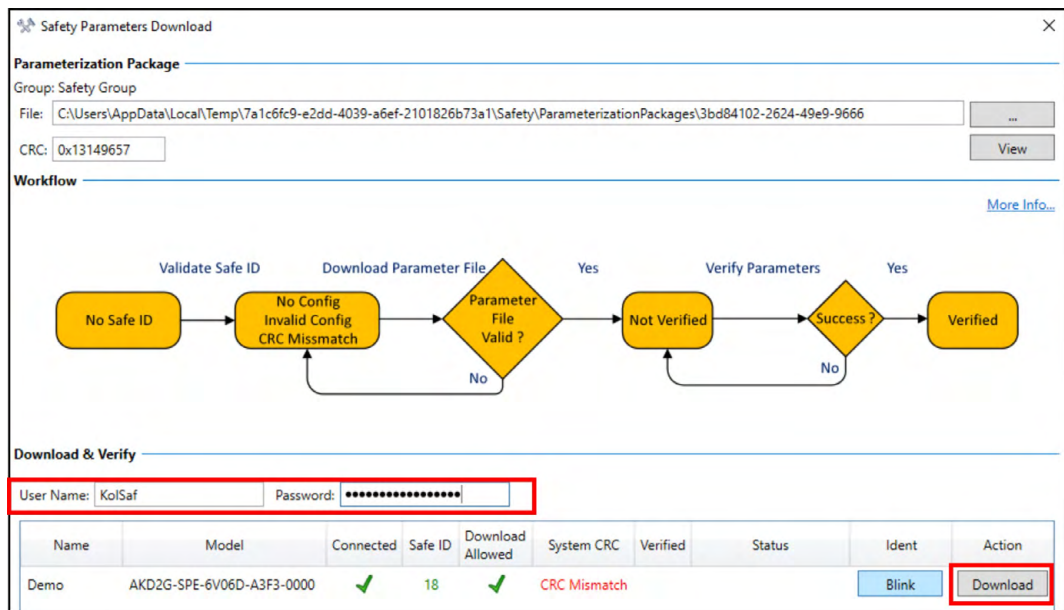

NOTICE

It is responsibility of the user to ensure, that the intended, matching parameter package is loaded to the drive. First enter the drive SafeID (1) manually and then click on "Verify" (2) to ensure, that the intended parameter package is in the drive.

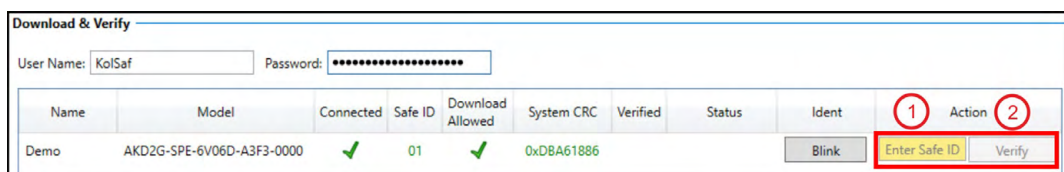

The safety configuration will be persistent, no configuration required after power cycle.

Download through EtherCAT FoE

The AKD2Gdrive supports the FoE (“File Access over EtherCAT”) protocol. It is possible for the user to download a safety parameter file to the drive and validate the safety configuration just via EtherCAT access.

The following main steps describe the process:

1. Create and export the safety parameter file via WorkBench.
Note: The exported file needs to be stored in the “i00” format.
2. Download the safety parameter file via FoE.
3. Validate the safe configuration via CoE (“CANopen over EtherCAT”) and SDO access.

The details for these main steps are written here:

Step 1: Export

See (Workbench Safety Function Setup, → # 193) for setting up the safety parameter for WorkBench. Once the safety configuration is done and the safety package has been created, the file can be exported.

The following example shows the screen that can be used to export the file. Select the “Export” button on the righthand side:

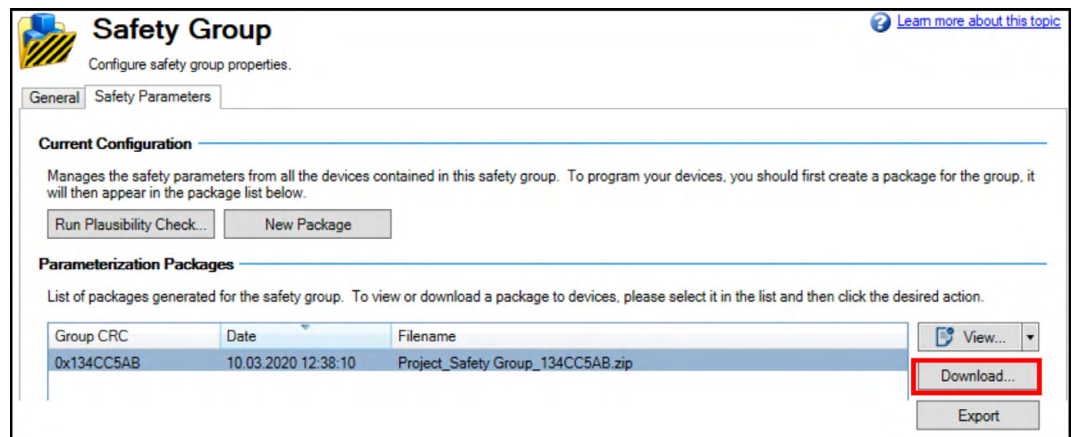

Set the file format to "i00" (“Save as type “i00”):

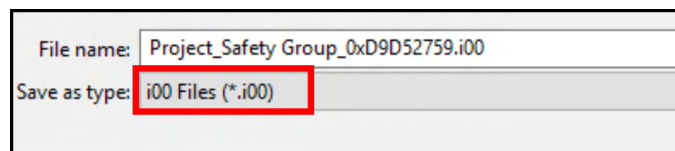

The file can now be used in the EtherCAT master for FoE download.

Step 2: Download

Before downloading the safety parameter file to the drive, the EtherCAT master must set the drive to the EtherCAT communication state “Boot”. Then the safety parameter file can be transferred the drive. The FoE protocol specific password is not needed to transfer the file to the drive.

The download of a corrupted or not compatible safety parameter file will generate an FoE error message (“Failed loading file to flash”). The SMM will stay in state 3 – “Configuration required”.

Step 3: Validation

The validation of the file needs to be done through SDO access.

NOTE

The state of the SMM will transition from 3 – “Configuration required” to 5 – “Parameter validation required” after a successful download of the safety parameter file. To perform the validation, the state of the SMM must be 5 – “Parameter validation required”. If not, the validation will be rejected by the system.

To validate the downloaded safety parameters, you must write the following EtherCAT CoE objects in the shown order:

1. User name (Index: 0x37C0, SubIndex: 0x01):
The User name is logged when the parameter validation is successful.
Format: 1..8 ASCII characters
2. Date and time (Index: 0x37C0, SubIndex: 0x02):
This time stamp is logged once the parameter validation is successful.
Format: YYYY-MM-DDThh:mm:ssZ
where Date: YYYY = year, MM = month, DD = day
and time: T = separator, hh = hour, mm =minute, ss =second, Z = time zone designator
Example: “2021-03-23T16:10:10Z”,
which is 3rd of March, 2021, 16:10:10 UTC
3. SafelD (Index: 0x37C0, SubIndex: 0x03):
The SafelD of the device that will be configured.
4. Password (Index: 0x37C0, SubIndex: 0x04):
The password to validate the downloaded safety parameters.
Format: 8 ... 25 ASCII characters

Important: The CoE object for the “Password” shall be written at last because it will trigger the validation process in the drive.

If the validation process is successful, the SDO access will create no abort message and the SMM will transition to state 6 – “Operational”.

If the validation process fails, the safety configuration will NOT be activated, the SMM will stay in state 5 – “Parameter Validation required” and the SDO write will create an abort message.

The safety configuration will be persistent, no configuration is required after power cycle.

Download through EtherCAT FSoE

The safety parameters file created with WorkBench can be downloaded through safe EtherCAT using FSoE (**F**ile **S**afe over **E**therCAT).

Usually, the FSoE master also supports SRA - “Safety related-application” parameters download. Then the safety configuration can be also sent to the drive using EtherCAT SDO access and FSoE. All safety parameters are available in the object dictionary and can be written individually using EtherCAT SDO. However, not all parameters have to be written. If a parameter is not written, then the default value (specified in the ESI file) is assumed.

The validation **must** be done through the FSoE master, which sends the SRA CRC to the AKD2G FSoE slaves during startup. This validation step can only be successful if the SMM was in state 3 – “Configuration required” prior to the validation process. If the drive has already a persistent safety configuration, the safety configuration must be cleared to set the SMM state to 3 – “Configuration required” (persistent safety parameters can be cleared using WorkBench through the Parameters viewer (→ # 204).

If the validation is successful, the SMM state will transition to state 6 – “Operational”. Otherwise, the SMM will stay in state 3 – “Configuration required”.

The safety configuration is non-persistent, that means this configuration will clear after a reboot or a reset of the FSoE connection.

10.4.6.4 Safety configuration diagram

A safety configuration status diagram pops up, when you click on the Safety indicator in the status bar.

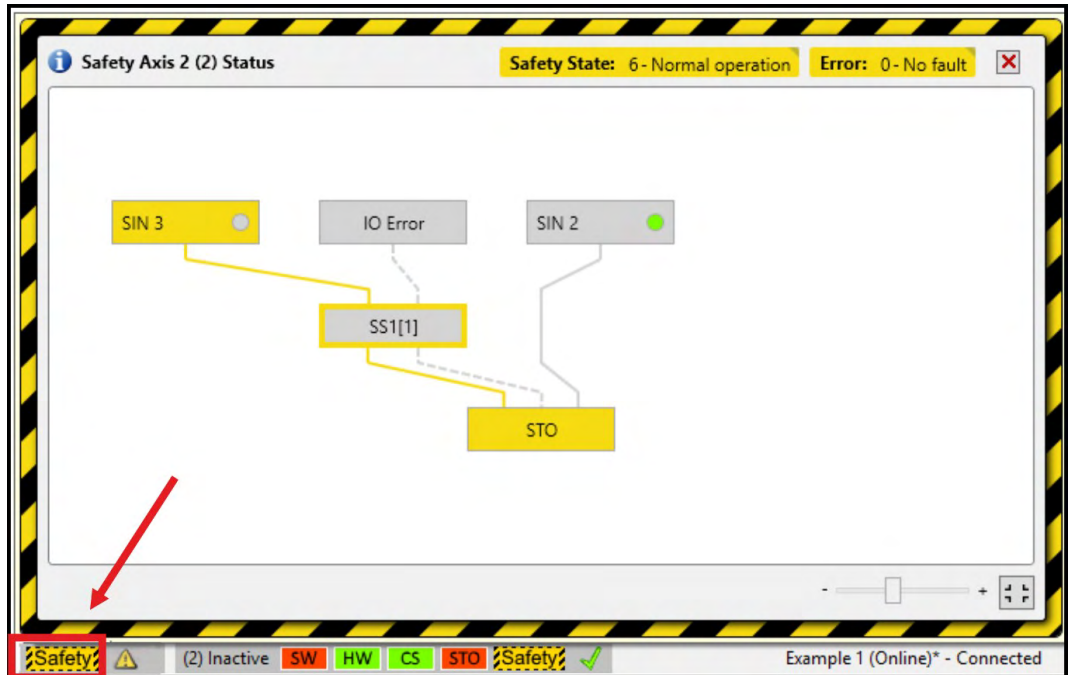

The configured safety functions are visible as well as the current safe I/O state.

10.4.6.5 Parameters Viewer

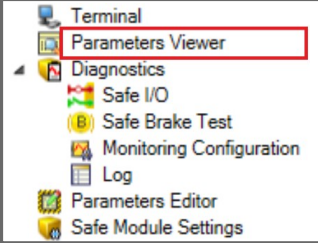
	<p>Displays actual values of all safety parameters set in the project.</p> <p>For details refer to the WorkBench online help.</p>
---	---

10.4.6.6 Diagnostics

For help with finetuning, debugging and verification of your safety project, WorkBench Diagnostics offers live information about internal safety related values.

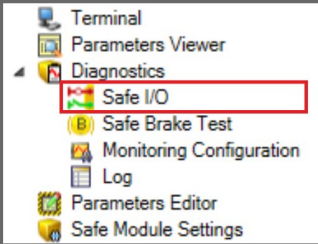
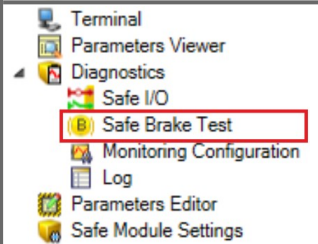
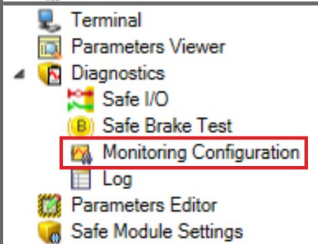
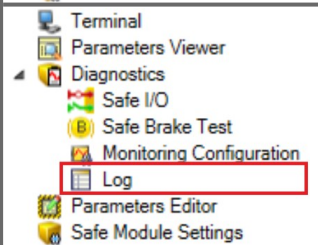
	<p>Displays the current configuration and values of the safe I/Os. It includes the dual configuration information for inputs and outputs and the source of the output signal.</p> <p>For details refer to the WorkBench online help.</p>
	<p>Displays the current safe brake configuration with the test status including the time remaining to the next test. The safe brake test can also be started and monitored from within that view.</p> <p>For details refer to the WorkBench online help.</p>
	<p>Information such as function states, safe velocity, safe position and safe acceleration can either be monitored directly or added to the Watch Panel for permanent surveillance or added to the WorkBench internal oscilloscope. Maximum two values can be observed simultaneously.</p> <p>For details refer to the WorkBench online help.</p>
	<p>Displays the log stored in the SMM. All actions related to SafeID and parameters validation are logged with username and date whenever possible.</p> <p>For details refer to the WorkBench online help.</p>

10.4.6.7 SMM Settings

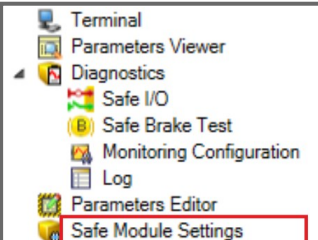
	<p>Configuration of SMM general parameters, for example a specific user password for parameter validation. It is not mandatory to configure this password, hence the root safety password is used as default.</p>
---	---

10.5 Validation

Validation is done on transferred parameters using CRC check. Parameters transferred by using FSoE (when FSoE parametrization is used) do not require user validation.

More information referring to parameter download (→ # 200).

10.5.1 User log-in

When you want to open a project in WorkBench, you must provide:

1. User name
2. Date and time
3. SafeID
4. Password

When the password is written to the object dictionary, the validation is triggered.

10.5.2 Validation of SafeID

If the SafeID is not flagged as validated when booting, a message will be displayed to the user: "SafeID not validated".

1. Read SafeID: Press the button B1 on the front of the drive to display the SafeID.
2. Compare the displayed SafeID with the paperwork.
3. If the SafeID is correct, press button B1 again within 10 seconds to validate.
4. If B1 is not pressed, the drive remains in the safe state.

Validation of the SafeID is performed through FSoE

- if FSoE parameterization is used and
- if the SafeID is not validated yet and
- if the SafeID matched the safe address defined in the safe PLC.

10.5.3 Validation of safety parameters

NOTE

The parameter CRC is equal to the system CRC. The character string of the SafeID is concatenated with the character string of the CRC.

The purpose of validation is to ensure that all safety parameters as a group are suitable for the application.

Example for invalid parameters: The parameters are valid for an elevator drive, but they are not for a paper machine drive.

The person responsible for validation must document decisions. Therefore the safety related system stores information about the user (user name, date of validation).

- The user checks the System CRC. This value is read from the drive (read the parameter value [SAFE.CRC](#)). This may require the user to sign a document about the correct parameters having been entered.
- The user must check, if all drives have been programmed correctly.
- The user requests a validation of all safety parameters. This is the exact moment when the user takes the responsibility for everything. The system adds the user name to the parameter set.

10.5.4 Validation of safe I/O installation

The installation of every drive must be validated by trained personnel after any changes to the installation. The expertise of the personnel must be appropriate to the complexity and safety integrity level of the drive system.

10.5.5 Validation Report

To assist commissioning and documentation, WorkBench offers to print a “Safe Motion Validation Report” suiting the safety parameter configuration. Select the corresponding safety parameter package (1). To view the validation report, click on “View” (2) directly or “View Validation Report” (3).

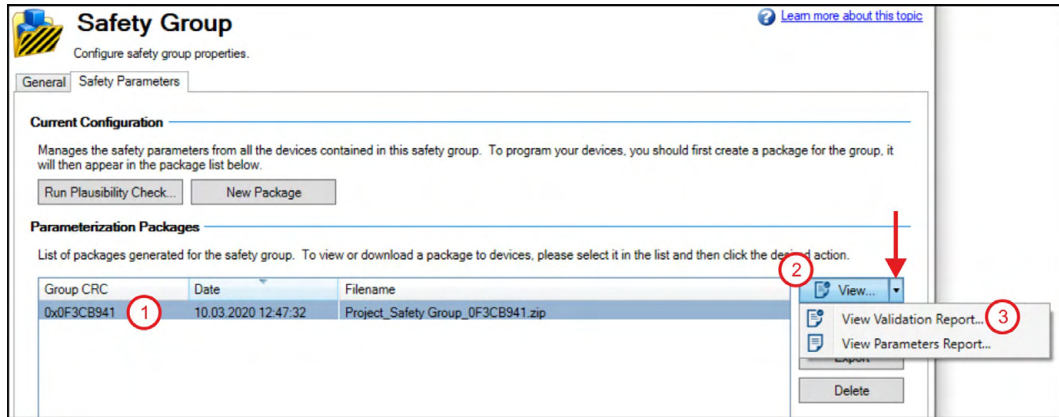

The “Safe Motion Validation Plan” lists all configured functions and their parameterized values (expected behavior). The validators can use it as guidance to verify all parameters and functions.

Example for a Validation Report (extract):

KOLLMORGEN
2020.01.22

AKD Safe Motion Validation Report

Machine Related Information

General Information:

Project name	Project Demo
Safety group	Demo Group
Company name	Kollmorgen
Validator 1	
Validator 2	
Machine type	Demo Machine
Comments	Demonstration for a possible Validation Report

Project and Components:

Source project filename	Project Demo.wbp
Safety package filename	Project Demo_Demo Group_A3157E81.zip
CRC for the safety group	0xA3157E81

Safe ID	23
Device name	Demo
Device model	AKD2G-SPE-6V06D-42F3-0000
Safety License	Basic Safety Features
Axes	
Axis 1 Safe Encoder	No Encoder
Axis 2 Safe Encoder	No Encoder

Validator 1:
Validator 2:
1 of 5

KOLLMORGEN
2020.01.22

Safe ID 23 - STO (Safe Torque Off)

Analysis of STO (Safe Torque Off) for device with Safe ID 23 (no_name)

Parameter	Value	Results
Axis 1 - Safe Stop - STO - Instance 1 (Fault Reaction)		
Function Activation	Ready for Activation	<input type="checkbox"/> OK <input type="checkbox"/> Not OK
Safe Input	Not Used	<input type="checkbox"/> OK <input type="checkbox"/> Not OK
FSoE	Not Used	<input type="checkbox"/> OK <input type="checkbox"/> Not OK
Restart Acknowledge Behavior	Manual Restart	<input type="checkbox"/> OK <input type="checkbox"/> Not OK
Restart Acknowledge Source	Safe input 3 (SIN3)	<input type="checkbox"/> OK <input type="checkbox"/> Not OK
Axis 2 - Safe Stop - STO - Instance 1 (Fault Reaction)		
Function Activation	Ready for Activation	<input type="checkbox"/> OK <input type="checkbox"/> Not OK
Safe Input	Safe dual input 1 (SW1/SIN2)	<input type="checkbox"/> OK <input type="checkbox"/> Not OK
FSoE	Not Used	<input type="checkbox"/> OK <input type="checkbox"/> Not OK
Restart Acknowledge Behavior	Manual Restart	<input type="checkbox"/> OK <input type="checkbox"/> Not OK
Restart Acknowledge Source	Safe input 4 (SIN4)	<input type="checkbox"/> OK <input type="checkbox"/> Not OK

Test of STO (Safe Torque Off) for device with Safe ID 23 (no_name)

Step	Required Action	Expected Behavior	Results
Axis 1 - Safe Stop - STO - Instance 1 (Fault Reaction)			
1	Move axis forward or backward.	Axis is moving.	<input type="checkbox"/> OK <input type="checkbox"/> Not OK
2	Activate STO on axis.	STO is activated on the axis.	<input type="checkbox"/> OK <input type="checkbox"/> Not OK
3	Check movement.	Axis is stopped, no movement.	<input type="checkbox"/> OK <input type="checkbox"/> Not OK
Axis 2 - Safe Stop - STO - Instance 1 (Fault Reaction)			
1	Move axis forward or backward.	Axis is moving.	<input type="checkbox"/> OK <input type="checkbox"/> Not OK
2	Activate STO on axis.	STO is activated on the axis.	<input type="checkbox"/> OK <input type="checkbox"/> Not OK
3	Check movement.	Axis is stopped, no movement.	<input type="checkbox"/> OK <input type="checkbox"/> Not OK

Validator 1:
Validator 2:
3 of 5

10.6 Operation

NOTICE

After the initial commissioning and validation, it must be ensured the initial state is permanently retained. Modification of any kind are prohibited without a proper modification process.

In case of a fault reaction occurring (STO-, SS1-Active without being activated on purpose) the drive should not be restarted before:

- the cause of the fault reaction is investigated and found;
- the reason of the fault reaction is removed/resolved;
- safe operation of the application is ensured.

Every occurring incident must be documented.

If the investigation of the fault reaction results in the discovery of a potential hazard or risk the application shall not return to normal operation before proper risk reduction is achieved.

In order to maintain functional safety, safety chains containing elements that cannot be tested regularly or without activation during normal operation, need to be periodically tested at least:

- once per year for SIL 2, PL d / Cat. 3;
- once every three months for SIL 3, PL e / Cat. 3;
- once every day for SIL 3, PL e / Cat. 4.

See IEC 61800-5-2 and ISO 13849 for further information.

In addition, tests for brakes need to be carried out independently (SBT (Safe Brake Test), → # 179).

The drive itself does not require any maintenance (Maintenance and cleaning, → # 25).

Replacement is only necessary in case of a defect or if the max. service life of the device TM is exceeded (Field replacement, → # 208).

Wear parts of safety chains such as relays, brakes or SDB modules, need to be swapped at the end of their lifetime as well as damaged or defect auxiliary equipment.

The replacement of any parts of the safety chain does not allow any changes or modifications to the safety characteristics or functionality of a safety chain. A new validation of the safety functions is necessary after working on any safety related equipment. In case of a modification a risk reevaluation and modification process needs to be carried out before retuning the drive to normal operation.

Every maintenance activity must be documented.

Periodic audits have to be carried out and documented in order to ensure the functional safety of the machine. Check the drives information display for faults and warnings regularly.

10.6.1 Operation States

The status bar in the WorkBench offers a brief overview of the safety operation status.

Safety bar indicator	Status
	No safety limitations (safety functions) are selected or active. The axis is in operational mode.
	The axis is not in an operational state. A warning that is not safety related prevents operation.
	The axis is not in an operational state. An error that is not safety related prevents operation.
	Safety limitations (safety functions) are active, such as SS1 or SOS. Safe operation is active!
	A safety function activated STO. Either STO was activated manually or a fault reaction occurred.
	Drive is in safe state and not operational. An internal failure or and I/O-failure occurred.

Clicking on the safety symbol will open a pop-up containing more detailed information on the safety configuration and status (→ # 204). The view offers information on which function(s) are or were activated, and which caused a fault reaction.

10.6.2 Field replacement

NOTICE

Field replacement must be performed by a trained person. After the drive is replaced and re-configured, the drive must be verified and proof tested before normal operation is started.

The drive that will be used as replacement must

- match the specification of the replaced drive in term of voltage, features and safety option, see "Part Number Scheme" (→ # 29),
- contain firmwares with same versions, particularly for the SMM. If not, a firmware upgrade must be performed (contact customer support),
- have invalidated safety parameters.

Reconfiguring the replacement drive

- Other drive on the same safety group or on the same machine should not be impacted by this process.
- Before power on, the replacement drive SafeID must match the one of the replaced drive. Change the rotary switches accordingly.
- Validate the new SafeID if needed during the boot of the drive, see "Validation" (→ # 205). It is important that the SafeID is configured and validated before downloading new parameters.
- Download safety parameters on the replacement drive. SafeID value is used to choose the right set of parameters for this drive (see "Safety Parameter Download" (→ # 200)). Depending on your application, this could be:
 - using WorkBench. Use the project of your safety application to download the parameters,
 - using non-safe field bus,
 - using FSoE.

10.7 Safety Faults, Safety Warnings

10.7.1 Drive LCD Display

The drive offers an LCD display and two push-buttons B1 / B2 for navigation.

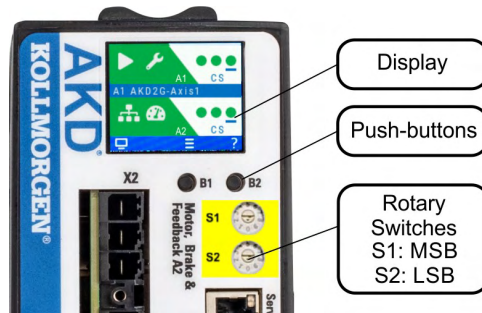

The display on the front panel of the drive shows the code of the fault or warning that occurred. Safety Faults and Warnings follow the same pattern and are identified by a four digit code 90 XX, where 90 is the two digit group code, and XX is a two digit ID.

Navigate with B1 / B2 to the Fault screen to see a short description of the fault or warning. See WorkBench Onlinehelp for details.

Example: dual axes, Fault Axis 2

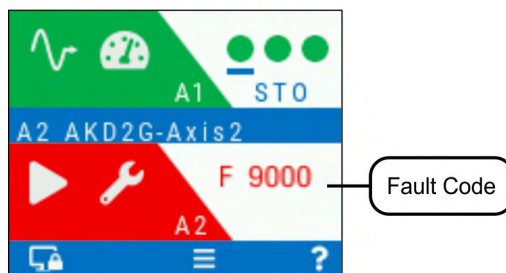

Example: single axis, Warning Axis 1

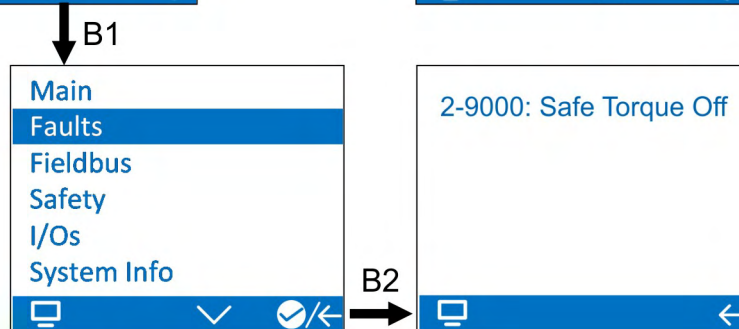
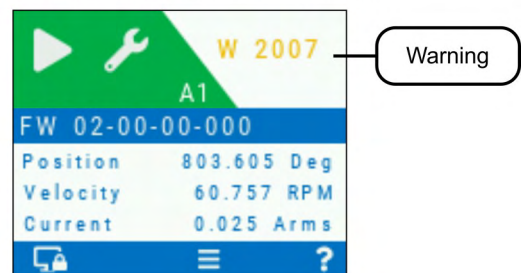

10.7.2 Failure categories

AKD2G with SMM (safety option 2) have the following safety circuit fault states:

Failure category		Description	Reaction
1	IO Failure	A problem is detected around the drive. Examples: encoder problem, missing OSSD test pulses or a wiring issue. Resolving: by the user or by using FSoE Restart: acknowledge fault, normal operation can be resumed.	
2	Internal failure	The drive detected a problem in the drive or in the internal SMM itself. The problem prevents further normal operation, but allows to transmit diagnostic data for diagnosis. Example: problem in switching the brake output. Resolving: power on / off Restart: not possible unless fault is removed.	If the velocity is >0, the drive decelerates. If the velocity = 0, the drive applies the brake and activates SS1 or STO.
3	Internal failure, reset may occur	The drive detected an internal problem, that may result in resets, and other erroneous behavior. As further operation cannot be executed safely, all communication is dropped. Resets of the internal SMM may occur. Example: RAM failure. Resolving: power on / off Restart: not possible unless fault is removed.	Safe outputs are off.

NOTE

An internal failure occurs, when a problem in the internal SMM is detected. Therefore, deceleration, applying the brakes and switching off the output may not be possible under all circumstances.

Safety Faults and Safety Warnings cannot be muted or suspended.

Stuck at faults on the STO output, the digital outputs or the brake output show up as IO failures or internal failures. Power supply faults (over and under voltage) show up as internal or fatal failure. Many diagnostic errors are false positives.

The fault tolerance time for each diagnostic measure (diagnostic test interval) is maximum $T_2 = 1$ h.

$\lambda_{DD} = 3.5E-6$ (Dangerous failure detected, per hour, each channel, with soft errors)

$\lambda_{TD} = 2.3E-6$ (Test failure detected, per hour, each channel, with soft errors)

In case of a detected failure, at least one of the two channels of an output is switched to the off state.

10.7.3 SMM failure classification and behavior

Der Parameter [SAFE.ERROR](#) gives the current error code of the SMM, accessible through CoE.

[SAFE.ERRORINSTANCE](#) indicates the current instance of the error code.

The SMM send the failure ID to the drive, if possible. The drive creates faults and warnings listed in the next chapter.

10.7.4 Drive Safety Faults

NOTE

More information about drive fault messages, remedy and clearing faults can be found in the WorkBench User Manual.

#	Description	Cause	Remedy
F9000	Safe torque off.	STO function has been triggered while the axis is enabled.	Reapply supply voltage to STO if safe to do so.
F9002	SMM Communication failed	SMM not communicating as expected	Restart drive. If issue persists, contact technical support.
F9003	Incorrect safety card detected	Physical SMM does not match the expected module	Restart drive. If issue persists, contact technical support.
F9004	Safe torque off digital and analog lines don't match	Hardware fault on the power board.	Restart drive. If issue persists, contact technical support.
F9005	STO Simultaneity	The two STO inputs did not change state within 100 ms of each other.	Check wiring and safety apparatus
F9006	Internal failure of the SMM	See SAFE.ERROR and SAFE.ERRORINSTANCE .	Restart drive. If issue persists, contact technical support.
F9007	Safe brake parameters inconsistent	AXIS#.SAFEPARAM.SBC.BRAKE#.ATTACHED indicates a brake is attached, but non-safe brake parameters (AXIS#.MOTOR.BRAKE, AXIS#.BRAKE) do not.	From the safety parameter screen in WorkBench under safe brake control (SBC), verify that the SBC Brake parameters agree with the drive related parameters that a brake is either configured or not.

10.7.5 Drive Safety Warnings

NOTE

More information about drive warnings can be found in the WorkBench User Manual.

#	Description	Cause	Remedy
W9000	Safe torque off.	STO function has been triggered.	Reapply supply voltage to STO if safe to do so.
W9007	Safe brake parameters inconsistent	AXIS#.SAFEPARAM.SBC . BRAKE#.ATTACHED indicates a brake is attached, but non-safe brake parameters (AXIS#.MOTOR.BRAKE, AXIS#.BRAKE) do not.	From the safety parameter screen in WorkBench under safe brake control (SBC), verify that the SBC Brake parameters agree with the drive related parameters that a brake is either configured or not.
W9008	Safe Brake Test Time Overflow	No SBT has been executed within the configured time limit	Extend SBT limit or execute an SBT
W9009	SMM Over Temperature	SMM is over temperature	Return hardware to manufacturer
W9010	SMM State not operational	SMM is not ready to enable. Refer to SAFE.STATE .	Verify SafeID and safe parameters are validated and correct. Check for other faults on the SMM.
W9011	SMM I/O failure detected	SMM detected a safety I/O failure and prohibits operation. <ul style="list-style-type: none"> ● Digital input failed ● STO pulse failed ● Brake output failed 	Determine cause and replace external hardware if issue reoccurs. I/O failure can be acknowledged with FSoE or a safe input (configurable).

10.7.6 Troubleshooting safety functionality

NOTICE

Eliminate errors and faults in compliance with work safety rules. Troubleshooting only by qualified and trained staff.

Problem	Possible Causes	Remedy causes
A group "90" safety fault or safety warning message is visible in the drive LCD display	Refer to the Drive Safety Fault and Warning tables (→ # 211).	
A fault or warning message of another group than "90" is visible in the drive LCD display	Refer to the drive fault and drive warnings tables (→ # 140) and more detailed descriptions in the WorkBench User Manual.	
Safety faults and warnings are not visible/reported	AXIS#.SAFE.STO.REPORTFAULT is set to 0	Set AXIS#.SAFE.STO.REPORTFAULT to 1
STO cannot be deactivated (no torque)	<ol style="list-style-type: none"> External safety device defective. STO wiring defective. Auxiliary voltage low. STO inputs defective. F9004 visible F9005 visible. OSSD pulses too long (>1ms). STO channels are unequal for more than 100ms. 	<ol style="list-style-type: none"> Check external safety device. Check STO wiring for short-circuit or similar. Check voltage level (→ # 156) . Send drive to manufacturer for repair. Send drive to manufacturer for repair. Check safety hardware system. Check safety controller. Switch off OSSD. Check external safety device.
Drive does not enable	1. STO is still active.	1. Deactivate STO prior to HW Enable.
SS1-t does not execute till the end of the configured time	Non-Safe emergency timeout interrupts the deceleration ramp of SS1-t.	Set emergency-timeout to a higher value than t_SS1
Safety Parameter package cannot be downloaded. Error message: "The parameter set does not contain parameters for this device"	The SafeID set in configuration does not match the SafeID set on the target Device.	Either parametrize the correct SafeID in the parameters or change the SafeID on the desired drive to the configured value, restart and validate the SafeID.
Monitoring Configuration: Monitoring field can not be added to scope	All sources of the scope are already occupied.	Remove at least one source / slot in the scope and try. Then add the desired monitoring field to scope.

10.8 Functional Safety Parameter Reference

Legend

- Acc. = Access: RO = Read Only, RW = Read/Write, WO = Write Only
- N/A = not available, Y = Yes, N = No
- Vel Unit = Velocity User Units, Acc Unit = Acceleration User Units, Dec Unit = Deceleration User Units, Pos Unit = Position User Units
- Parameters are sorted alphanumeric

Parameters related to safety functions	Acc.	Default	Parameter Package	CAN over EtherCAT			FSoE Object
				Axis1 Index 0x....	Axis2 Index 0x....	Sub	
AXIS#.SAFE.ACTIVE	RO	N/A	N/A	5007	5107	5	N
AXIS#.SAFE.BRAKE#.STATE	RO	N/A	N/A	N/A	N/A	N/A	N
AXIS#.SAFE.ERROR.ACTIVE	RO	N/A	N/A	N/A	N/A	N/A	N
AXIS#.SAFE.FSOE.APPLPARAMLENGTH	RO	N/A	N/A	E901	E911	8	N
AXIS#.SAFE.FSOE.COMMPARAMLENGTH	RO	N/A	N/A	E901	E911	7	N
AXIS#.SAFE.FSOE.CONNECTIONID	RO	N/A	N/A	E901	E911	3	N
AXIS#.SAFE.FSOE.CONNECTIONTYPE	RO	N/A	N/A	E901	E911	6	N
AXIS#.SAFE.FSOE.LASTEROR	RO	N/A	N/A	N/A	N/A	N/A	N
AXIS#.SAFE.FSOE.PROTOCOLVERSION	RO	N/A	N/A	E901	E911	1	N
AXIS#.SAFE.FSOE.SAFETYADDR	RO	N/A	N/A	E901	E911	2	N
AXIS#.SAFE.FSOE.SRACRC	RO	N/A	N/A	E901	E911	9	N
AXIS#.SAFE.FSOE.STATE	RO	N/A	N/A	N/A	N/A	N/A	N
AXIS#.SAFE.FSOE.WATCHDOGTIME	RO	N/A	N/A	E901	E911	4	N
AXIS#.SAFE.FUNCTIONGRAPH	RO	N/A	N/A	N/A	N/A	N/A	N
AXIS#.SAFE.FUNCTIONSTATUS	RO	N/A	N/A	N/A	N/A	N/A	N
AXIS#.SAFE.RESTARTACK.REQUESTED	RO	N/A	N/A	N/A	N/A	N/A	N
AXIS#.SAFE.SBC.ACTIVE	RO	N/A	N/A	2061	2161	0	Y
AXIS1.SAFE.SBT.ERROR	RO	N/A	N/A	40F1	-	1	N
AXIS2.SAFE.SBT.ERROR	RO	N/A	N/A	-	40F1	2	N
AXIS1.SAFE.SBT.MOVE	WO	N/A	N/A	2FC0	-	1	N
AXIS2.SAFE.SBT.MOVE	WO	N/A	N/A	-	2FC0	2	N
AXISx.SAFE.SBT.SBA.ACTIVE	RO	N/A	N/A	2060	2161	0	Y
AXIS1.SAFE.SBT.STATE	RO	N/A	N/A	40F0	-	1	N
AXIS2.SAFE.SBT.STATE	RO	N/A	N/A	-	40F0	2	N
AXIS#.SAFE.SS1_#.ACTIVE	RO	N/A	N/A	665F	6E5F	Inst1: 1 Inst2: 2 Inst3: 3	Y
AXIS#.SAFE.SS1_#.DEC	RW	div	Drive	N/A	N/A	N/A	N
AXIS#.SAFE.SS1_#.INTERNALSTATE	RO	N/A	N/A	N/A	N/A	N/A	N
AXIS#.SAFE.SS1_#.MODE	RW	0	Drive	N/A	N/A	N/A	N
AXIS#.SAFE.STO.ACTIVE	RO	N/A	N/A	6640	6E40	0	Y
AXIS#.SAFE.STO.REPORTFAULT	RW	1	Drive	5007	5007	1	N
AXIS#.SAFE.TEMPWARNING.ACTIVE	RO	N/A	N/A	N/A	N/A	N/A	N
AXIS1.SAFEPARAM.AXISCFGEN	RO	1	Safety	3100	-	2	N
AXIS2.SAFEPARAM.AXISCFGEN	RO	1	Safety	-	3100	3	N
AXIS#.SAFEPARAM.SBC.BRAKETIMEDELAY	RW	100ms	Safety	3156	3256	3	N
AXIS1.SAFEPARAM.SBC.BRAKE1ATTACHED	RW	1	Safety	3156	-	4	N
AXIS1.SAFEPARAM.SBC.BRAKE2ATTACHED	RW	0	Safety	3156	-	5	N
AXIS2.SAFEPARAM.SBC.BRAKE1ATTACHED	RW	0	Safety	-	3256	4	N
AXIS2.SAFEPARAM.SBC.BRAKE2ATTACHED	RW	1	Safety	-	3256	5	N
AXIS#.SAFEPARAM.SBC.MUTINGSOURCE	RW	0	Safety	3156	3256	4	N
AXIS#.SAFEPARAM.SBT.FUNCTIONACTIVATION	RW	1	Safety	3157	3257	1	N
AXIS#.SAFEPARAM.SBT.MAXAPPLLOAD	RW	1000mA	Safety	3157	3257	3	N
AXIS1.SAFEPARAM.SBT.MAXMOTIONBRAKE1	RW	300arcmin	Safety	3157	-	4	N

Parameters related to safety functions	Acc.	Default	Parameter Package	CAN over EtherCAT			FSoE Object
				Axis1 Index 0x....	Axis2 Index 0x....	Sub	
AXIS1.SAFEPARAM.SBT.MAXMOTIONBRAKE2	RW	300arcmin	Safety	3157	-	5	N
AXIS2.SAFEPARAM.SBT.MAXMOTIONBRAKE1	RW	300arcmin	Safety	-	3257	4	N
AXIS2.SAFEPARAM.SBT.MAXMOTIONBRAKE2	RW	300arcmin	Safety	-	3257	5	N
AXIS#.SAFEPARAM.SBT.MAXTIMEINTERVAL	RW	480min	Safety	3157	3257	2	N
AXIS#.SAFEPARAM.SBT.TORQUEDURATION	RW	500ms	Safety	3157	3257	6	N
AXIS#.SAFEPARAM.SDB.DELAYBEFOREDIAGNOSE	RW	1ms	Safety	3158	3258	4	N
AXIS#.SAFEPARAM.SDB.DELAYBEFORESWITCHING	RW	1ms	Safety	3158	3258	3	N
AXIS#.SAFEPARAM.SDB.FUNCTIONACTIVATION	RW	0	Safety	3158	3258	1	N
AXIS#.SAFEPARAM.SDB.READBACKSOURCE	RW	0	Safety	3158	3258	3	N
AXIS#.SAFEPARAM.SS1_#.FSOE	RW	0	Safety	Inst1: 3153 Inst2: 3154 Inst3: 3155	Inst1: 3253 Inst2: 3254 Inst3: 3255	3	N
AXIS#.SAFEPARAM.SS1_#.FUNCTIONACTIVATION	RW	Inst1: 1 Inst2: 0 Inst3: 0	Safety	Inst1: 3153 Inst2: 3154 Inst3: 3155	Inst1: 3253 Inst2: 3254 Inst3: 3255	1	N
AXISx.SAFEPARAM.SS1_#.SAFEINPUT	RW	0	Safety	Inst1: 3153 Inst2: 3154 Inst3: 3155	Inst1: 3253 Inst2: 3254 Inst3: 3255	2	N
AXIS#.SAFEPARAM.SS1_#.TIMETOSTO	RW	2ms	Safety	Inst1: 3153 Inst2: 3154 Inst3: 3155	Inst1: 3253 Inst2: 3254 Inst3: 3255	4	N
AXIS#.SAFEPARAM.STO.FSOE	RW	0	Safety	3152	3252	3	N
AXIS#.SAFEPARAM.STO.FUNCTIONACTIVATION	RW	1	Safety	3152	3252	1	N
AXIS#.SAFEPARAM.STO.RESTARTACKMODE	RW	0	Safety	3152	3252	4	N
AXIS#.SAFEPARAM.STO.RESTARTACKSOURCE	RW	0	Safety	3152	3252	5	N
AXIS1.SAFEPARAM.STO.SAFEINPUT	RW	5	Safety	3152	-	2	N
AXIS2.SAFEPARAM.STO.SAFEINPUT	RW	6	Safety	-	3252	2	N
BRAKE1.SAFE.SBT.ELAPSED	RO	N/A	N/A	40F2		1	N
BRAKE2.SAFE.SBT.ELAPSED	RO	N/A	N/A	40F2		2	N
BRAKE1.SAFE.SBT.STATE	RO	N/A	N/A	40F3		1	N
BRAKE2.SAFE.SBT.STATE	RO	N/A	N/A	40F3		2	N
SAFE.CFGERROR	RO	N/A	N/A	N/A		N/A	N
SAFE.CHANGEPASSWORD	WO	N/A	N/A	N/A		N/A	N
SAFE.CLEARSAFEID	WO	N/A	N/A	N/A		N/A	N
SAFE.CRC	RO	N/A	N/A	37C3		0	N
SAFE.DEVICECRC	RO	N/A	N/A	N/A		N/A	N
SAFE.ERROR	RO	N/A	N/A	37C4		0	N
SAFE.ERRORINSTANCE	RO	N/A	N/A	N/A		N/A	N
SAFE.ID	RO	N/A	N/A	N/A		N/A	N
SAFE.IDANDCRC	RO	N/A	N/A	N/A		N/A	N
SAFE.INVALIDATEPARAMS	WO	N/A	N/A	N/A		N/A	N
SAFE.MONITOR#.AXIS	RW	0	N/A	N/A		N/A	N
SAFE.MONITOR#.DATA	RO	N/A	N/A	N/A		N/A	N
SAFE.MONITOR#.INSTANCE	RW	0	N/A	N/A		N/A	N
SAFE.MONITOR#.SOURCE	RW	0	N/A	N/A		N/A	N
SAFE.STATE	RO	N/A	N/A	37C1		0	N
SAFE.SWITCH	RO	N/A	N/A	37C2		0	N
SAFE.VALIDATEPARAM	WO	N/A	N/A	37C0		1,2,3,4	N
SAFE.VALIDATIONLOG	RO	N/A	N/A	N/A		N/A	N
SAFE.VERIFYFW	WO	N/A	N/A	N/A		N/A	N
SAFEPARAM.IOFAILUREACKSOURCE	RW	0	Safety	3100		1	N
SAFEPARAM.SAFEFIELDBUS.ACTIVATION	RW	0	Safety	N/A		N/A	N
SAFEPARAM.SIN.DISTINCTPULSE	RW	0	Safety	3101		1	N

Parameters related to safety functions	Acc.	Default	Parameter Package	CAN over EtherCAT			FSoE Object
				Axis1 Index 0x....	Axis2 Index 0x....	Sub	
SAFEPARAM.SINDUAL#.EN	RW	1	Safety	3101		Inst1: 2 Inst2: 3	N
SAFEPARAM.SOUTDUAL#.EN	RW	0	Safety	3102		Inst1: 1 Inst2: 2	N
SAFEPARAM.SOUTDUAL#.SOURCE	RW	0	Safety	3102		Inst1: 3 Inst2: 4	N
SAFEPARAM.SOUT#.SOURCE	RW	0	Safety	3102		Inst1: 5 Inst2: 6 Inst3: 7 Inst4: 8	N
SINDUAL#.STATE	RO	N/A	N/A	N/A		N/A	N
SIN#.STATE	RO	N/A	N/A	N/A		N/A	N
SOUTDUAL#.STATE	RO	N/A	N/A	N/A		N/A	N
SOUT#.STATE	RO	N/A	N/A	N/A		N/A	N

10.8.1 Safety Parameters, sorted alphanumeric

10.8.1.1 AXIS#.SAFE.ACTIVE

Description

This value returns a bit field of all active safety functions for information only.

Bit pos.	Value	Contents
0	STO state	= 1 when STO is active
1 to 6	reserved	Functional Safety Option 3 only
7	Error active	= 1 when an error is active
8 to 14	reserved	Functional Safety Option 3 only
15	Not used	Not used
16 to 18	reserved	Functional Safety Option 3 only
19	SS1 status Instance 1	= 1 while SS1 is active
20	SS1 status Instance 2	= 1 while SS1 is active
21	SS1 status Instance 3	= 1 while SS1 is active
22 to 31	reserved	Functional Safety Option 3 only

General Information

Type	Read Only
Description	A bit field to show which safety functions are active.
Units	Bit field
Default Value	0
Data Type	U32

10.8.1.2 AXIS#.SAFE.BRAKE#.STATE

Description

Indicates the internal state of the brake state machine.

Value	Description
0	Brake engaged
1	Releasing brake
2	Brake released
3	Engaging brake

Context

For complete SBC information refer to "SBC (Safe Brake Control)" (→ # 171).

Versions

Action	Version	Notes
Implemented	02-00-00-000	

General Information

Type	Read Only
Units	N/A
Range	0 or 4
Default Value	0
Data Type	Integer
Stored in Non Volatile Memory	No

10.8.1.3 AXIS#.SAFE.ERROR.ACTIVE**Description**

Indicates whether the safety system is in error or not. [SAFE.ERROR](#) and [SAFE.ERRORINSTANCE](#) can be used to retrieve information about the error.

Value	Description
0	No error
1	Error

Versions

Action	Version	Notes
Implemented	02-04-00-000	Implemented in SMM revision v0.56

General Information

Type	Read Only
Units	N/A
Range	0, 1
Default Value	N/A
Data Type	Integer
Stored in Non Volatile Memory	No

10.8.1.4 AXIS#.SAFE.FSOE.APPLPARAMLENGTH**Description**

Indicates the size of the FSoE application parameters. If using WorkBench safety parameters, this is 0 and if using application parameters over FSoE it is 4 bytes.

Context

For complete FSoE information refer to the *AKD2G EtherCAT Manual*.

Versions

Action	Version	Notes
Implemented	02-01-02-000	

General Information

Type	Read Only
Units	N/A
Range	0-65535
Default Value	N/A
Data Type	Integer
Stored in Non Volatile Memory	No

10.8.1.5 AXIS#.SAFE.FSOE.COMMPARAMLENGTH**Description**

Indicates the length of FSoE communication parameters. This is fixed at 2 bytes because the only com parameter transferred is the watchdog time which is U16.

Context

For complete FSoE information refer to the *AKD2G EtherCAT Manual*.

Versions

Action	Version	Notes
Implemented	02-01-02-000	

General Information

Type	Read Only
Units	N/A
Range	2
Default Value	N/A
Data Type	Integer
Stored in Non Volatile Memory	No

10.8.1.6 AXIS#.SAFE.FSOE.CONNECTIONID**Description**

Indicates the current FSoE connection id assigned by the FSoE master once the connection FSoE state is reached.

Context

For complete FSoE information refer to the *AKD2G EtherCAT Manual*.

Versions

Action	Version	Notes
Implemented	02-01-02-000	

General Information

Type	Read Only
Units	N/A
Range	1-65535
Default Value	N/A
Data Type	Integer
Stored in Non Volatile Memory	No

10.8.1.7 AXIS#.SAFE.FSOE.CONNECTIONTYPE**Description**

This returns the FSoE connection type parameter. In the case of the AKD2G, this value is a constant 2 to indicate a slave device.

Context

For complete FSoE information refer to the *AKD2G EtherCAT Manual*.

Versions

Action	Version	Notes
Implemented	02-01-02-000	

General Information

Type	Read Only
Units	N/A
Range	2
Default Value	N/A
Data Type	Integer
Stored in Non Volatile Memory	No

10.8.1.8 AXIS#.SAFE.FSOE.LASTERROR**Description**

This parameter gives the last error shown to the Fail Safe over EtherCAT (FSoE) stack with one of the following values:

Value	Description
0	Local reset or acknowledgement of a RESET command
1	Unexpected command
2	Unknown command
3	Invalid connection ID
4	CRC error
5	Watchdog has expired
6	Invalid FSoE slave address
7	Invalid safety data
8	Invalid communication parameter length
9	Invalid communication parameter data
10	Invalid application parameter length
11	Invalid application parameter data

Context

For complete FSoE information refer to the *AKD2G EtherCAT Manual*.

Versions

Action	Version	Notes
Implemented	02-01-02-000	Implemented in SMM v0.54

General Information

Type	Read Only
Units	N/A
Range	0, 0xFF
Default Value	N/A
Data Type	Integer
Stored in Non Volatile Memory	No

10.8.1.9 AXIS#.SAFE.FSOE.PROTOCOLVERSION**Description**

Version of the FSoE protocol in use.

Context

For complete FSoE information refer to the *AKD2G EtherCAT Manual*.

Versions

Action	Version	Notes
Implemented	02-01-02-000	

General Information

Type	Read Only
Units	N/A
Range	0-65535
Default Value	N/A
Data Type	Integer
Stored in Non Volatile Memory	No

10.8.1.10 AXIS#.SAFE.FSOE.SAFETYADDR**Description**

FSoE safety address for this axis. Format of safety address is nn where nn is the SafeID and aa is the axis id.

Example

If SafeID is 10 then AXIS1.SAFE.FSOE.SAFETYADDR is 1001 and AXIS2.SAFE.FSOE.SAFETYADDR is 1002.

Context

For complete FSoE information refer to the *AKD2G EtherCAT Manual*.

Versions

Action	Version	Notes
Implemented	02-01-02-000	

General Information

Type	Read Only
Units	N/A
Range	101 to 9901 for Axis 1 102 to 9902 for Axis 2
Default Value	N/A
Data Type	Integer
Stored in Non Volatile Memory	No

10.8.1.11 AXIS#.SAFE.FSOE.SRACRC**Description**

Returns the Safety Related Application (SRA) Cyclic Redundancy Check (CRC) used to validate safety parameters through Fail Safe over EtherCAT (FSoE).

Versions

Action	Version	Notes
Implemented	02-04-00-000	Implemented in SMM revision v0.56

General Information

Type	Read Only
Units	N/A
Range	N/A
Default Value	N/A
Data Type	Integer
Stored in Non Volatile Memory	No

10.8.1.12 AXIS#.SAFE.FSOE.STATE**Description**

This is the EtherCAT FSoE command word being sent to the drive from the FSoE master.

Value	Description
0x36	ProcessData – Process data is passed between FSoE master and slave.
0x2A	Reset – FSoE communication is in reset state.
0x4E	Session – FSoE session is being established between master and slave.
0x64	Connection – FSoE connection is being established between master and slave.
0x52	Parameter – Safe parameters are being downloaded to slave.
0x08	FailSafeData – Fail-safe values are being used (usually due to an error).

Context

For complete FSoE information refer to the *AKD2G EtherCAT Manual*.

Versions

Action	Version	Notes
Implemented	02-01-02-000	

General Information

Type	Read Only
Units	N/A
Range	0x08, 0x2A, 0x36, 0x4E, 0x52, 0x64
Default Value	N/A
Data Type	Integer
Stored in Non Volatile Memory	No

10.8.1.13 AXIS#.SAFE.FSOE.WATCHDOGTIME**Description**

The current FSoE watchdog time in milliseconds. If an FSoE packet is not received within the configured time the drive enters a safe state. This is configured by using the FSoE master.

Context

For complete FSoE information refer to the *AKD2G EtherCAT Manual*.

Versions

Action	Version	Notes
Implemented	02-01-02-000	

General Information

Type	Read Only
Units	N/A
Range	7 to 65535
Default Value	100
Data Type	Integer
Stored in Non Volatile Memory	No

10.8.1.14 AXIS#.SAFE.FUNCTIONGRAPH

This parameter returns the graph of the safety functions configured in the safety parameters.

The following format is used:

NODEID: Name(**NODENAME**); Type(**NODETYPE**); State(**NODESTATE**); FunctionSource(**LIST_OF_FUNCTION_SOURCE**); FaultReactionSource(**LIST_OF_FAULT_REACTION**); InputSource(**LIST_OF_INPUTSOURCE**); FSoESource(**LIST_OF_FSOE_SOURCE**); Properties(**LIST_OF_PROPERTIES**)

- **NODEID**: node unique id, built as follows:
 - Safe functions: SOS, SS1_1, SLS_3, ...
 - Safe inputs: SIN1_SOS, SINDUAL2_SS1_2, ...
 - FSoE: FSOE_SOS, FSOE_SS1_1, ...
 - I/O Error: IOError
- **NODENAME**: function name to display (eg FSoE, SIN1, SS1_1, ...) [displayed in the block]
- **NODETYPE**: node type – SIN, SINDUAL, FSOE, FUNCTION, ERROR [type of graphical block]
- **NODESTATE** can be: [colorization of the block]
 - For FUNCTION: “Idle”, “ProcessComplete”, “Active”, “Faulted”
 - For SIN, SINDUAL or FSoE: “On”, “Off”
 - For ERROR: “Normal”, “Error”
- **LIST_OF_FUNCTION_SOURCE**, **LIST_OF_FAULT_REACTION**, **LIST_OF_INPUTSOURCE** and **LIST_OF_FSOE_SOURCE** are a list of **NODEIDs** separated by a comma
- **LIST_OF_PROPERTIES**: string list to display separated by commas

Versions

Action	Version	Notes
Implemented	Next release	Implemented in SMM revision v0.54

General Information

Type	Info
Units	N/A
Range	N/A
Default Value	N/A
Data Type	N/A
Stored in Non Volatile Memory	N/A

10.8.1.15 AXIS#.SAFE.FUNCTIONSTATUS**Description**

This value returns a bit field which contains a status for some safety functions. The bit field is described in the following table:

Bit	Value	Contents
0	STO state	= 1 when STO is active
1	SSM state Instance 1	= 1 when SSM Instance 1 reports the speed in the given range
2	SSM state Instance 2	= 1 when SSM Instance 2 reports the speed in the given range
3	SOS state	= 1 when SOS is active
4	SSR Instance 1	= 1 while the speed is limited
5	SDIp status	= 1 when the motor is moving in positive direction
6	SDIn status	= 1 when the motor is moving in negative direction
7	Error active	= 1 when an error is active
8	SCA Instance 1	= 1 while the position is within the given limits
9	SCA Instance 2	= 1 while the position is within the given limits
10	SCA Instance 3	= 1 while the position is within the given limits
11	SLA state	= 1 while the limited acceleration is held
12	SAR Instance 3	= 1 while the acceleration is limited
13	SSR Instance 2	= 1 while the speed is limited
14	SSR Instance 3	= 1 while the speed is limited
15	Not used	Not used
16	SLS state Instance 1	= 1 while the limited speed is held
17	SLS state Instance 2	= 1 while the limited speed is held
18	SLS state Instance 3	= 1 while the limited speed is held
19	SS1 status Instance 1	= 1 while SS1 is active
20	SS1 status Instance 2	= 1 while SS1 is active
21	SS1 status Instance 3	= 1 while SS1 is active
22	SS2 status Instance 1	= 1 while SS2 is active
23	SS2 status Instance 2	= 1 while SS2 is active
24	SLI Instance 1	= 1 while the position is limited
25	SLI Instance 2	= 1 while the position is limited
26	SLI Instance 3	= 1 while the position is limited
27	SLP Instance 1	= 1 while the position is limited
28	SLP Instance 2	= 1 while the position is limited
29	SLP Instance 3	= 1 while the position is limited
30	SAR Instance 1	= 1 while the acceleration is limited
31	SAR Instance 2	= 1 while the acceleration is limited
32	SDIp active	= 1 when is not allowed to move in the positive direction
33	SDIn active	= 1 when is not allowed to move in the negative direction

Versions

Action	Version	Notes
Implemented		

General Information

Type	Read Only
Units	Bit field
Default Value	0
Data Type	U64
Stored in Non Volatile Memory	No

10.8.1.16 AXIS#.SAFE.RESTARTACK.REQUESTED**Description**

Indicates whether an acknowledge is requested by Safe Operating Stop (SOS) or Safe Torque Off (STO) to restart. When the acknowledge is requested, the parameter is 1, otherwise 0. Restart acknowledge is requested when:

- STO or SOS is configured to restart manually.
- The condition which activates STO or SOS is cleared.

Value	Description
0	No restart acknowledges requested
1	Restart acknowledge requested

Versions

Action	Version	Notes
Implemented	2-00-00-000	Implemented in SMM revision v0.56

General Information

Type	Read Only
Units	N/A
Range	0, 1
Default Value	N/A
Data Type	Integer
Stored in Non Volatile Memory	No

10.8.1.17 AXIS#.SAFE.SBC.ACTIVE**Description**

Indicates whether Safe Brake Control (SBC) is active or not. When SBC is active the brake cannot be commanded to release. If SBC is enabled, it is executed once stopped during all stopping safety functions. Once the safety function condition clears, SBC will stop and allow the brake to be released.

Context

For complete SBC information refer to "SBC (Safe Brake Control)" (→ # 171).

Versions

Action	Version	Notes
Implemented	02-01-02-000	

General Information

Type	Read Only
Units	N/A
Range	0 or 1
Default Value	N/A
Data Type	Integer
Stored in Non Volatile Memory	No

10.8.1.18 AXIS#.SAFE.SBT.ERROR**Description**

Read the error of the Safe Brake Test (SBT) on the specified axis. The return value can be one of the following:

Value	Description
0	No error.
1	Fail to start the safe brake test. To start safe brake test, the axis must be enabled, the attached brakes must be released, and the axis must be at standstill.
2	Brakes are not released. To start safe brake test, the axis must be enabled, the attached brakes must be released, and the axis must be at standstill.
3	Fail to apply the brake. To find which brakes failed, see (→ # 251).
4	Fail to release the brake. To find which brakes failed, see (→ # 251).
5	Fail to apply current on the axis.
6	Motion limit exceed. Brake may be broken. To find which brakes failed, see (→ # 251).
7	Current feedback out of range. To find which brakes failed, see (→ # 251).
8	Communication error between the non-safe system part and the SMM.
9	Timeout. The safe brake test wasn't able to complete.
10	System error on the SMM.
11	Interrupted by user.
12	Measured load is bigger than the configured maximum load.
255	Unknown error.

Code

```
--> AXIS1.SAFE.SBT.ERROR
0
```

Context

For complete SBT information refer to "SBT (Safe Brake Test)" (→ # 179).

Versions

Action	Version	Notes
Implemented	02-00-00-000	Implemented in SMM revision v0.32

General Information

Type	Read Only
Units	N/A
Range	0 - 11
Default Value	N/A
Data Type	Integer
Stored in Non Volatile Memory	No

10.8.1.19 AXIS#.SAFE.SBT.MOVE**Description**

Execute Safe Brake Test (SBT) on the specified axis. All brakes attached to this axis are tested. A maximum of two brakes can be attached to a specific axis. For this command to work, Safe Brake Control (SBC) and SBT must be configured consistently in the SMM using safety parameters.

Code

```
--> AXIS1.SAFE.SBT.MOVE
```

Context

For complete SBT information refer to "SBT (Safe Brake Test)" (→ # 179).

Versions

Action	Version	Notes
Implemented	02-00-00-000	Implemented in SMM revision v0.32

General Information

Type	Command
Units	N/A
Range	N/A
Default Value	N/A
Data Type	N/A
Stored in Non Volatile Memory	No

10.8.1.20 AXIS#.SAFE.SBT.SBA.ACTIVE**Description**

Indicates the safe brake acknowledge state.

Value	Description
1	Brake needs an acknowledge.
0	Brake does not need an acknowledge. The brake state is safe.

Context

For complete SBC/SBT information refer to "SBC (Safe Brake Control)" (→ # 171) / "SBT (Safe Brake Test)" (→ # 179).

Versions

Action	Version	Notes
Implemented	02-02-00-000	

General Information

Type	Read Only
Units	N/A
Range	0 or 1
Default Value	N/A
Data Type	Integer
Stored in Non Volatile Memory	No

10.8.1.21 AXIS#.SAFE.SBT.STATE**Description**

Read the state of the Safe Brake Test (SBT) on the specified axis. The return value can be one of the following:

Value	Description
0	The test is not running.
1	The test is starting.
2	The test is started.
3	The brake is tested.
4	The test is stopping.

Code

```
--> AXIS1.SAFE.SBT.STATE
0
```

Context

For complete SBT information refer to "SBT (Safe Brake Test)" (→ # 179).

Versions

Action	Version	Notes
Implemented	2-00-00-000	Implemented in SMM revision v0.32

General Information

Type	Read Only
Units	N/A
Range	0, 1, 2, 3
Default Value	N/A
Data Type	Integer
Stored in Non Volatile Memory	No

10.8.1.22 AXIS#.SAFE.SS1_#.ACTIVE**Description**

Indicates whether the specified safe stop instance is active. This signal is set to 1 when Safe Stop 1 (SS1) is activated. When finally SS1 activates the STO function (often after SS1_#.TIMETOSTO but it could be before if you are using a safe encoder), this active signal transition back to 0.

Context

For complete SS1 information refer to (→ # 166).

Versions

Action	Version	Notes
Implemented	02-01-02-000	

General Information

Type	Read Only
Units	N/A
Range	0 or 1
Default Value	N/A
Data Type	Integer
Stored in Non Volatile Memory	No

10.8.1.23 AXIS#.SAFE.SS1_#.DEC**Description**

Sets the deceleration rate for the corresponding safe stop instance. When the safe stop instance is executed via safe input or FSoE the drive will attempt to stop following the associated deceleration rate. If multiple safe stop instances occur at the same time, the instance with the fastest deceleration rate will be used.

NOTE

If [AXIS#.SAFE.SS1_#.MODE](#) is set to fieldbus control, the drive will not decelerate on its own and this parameter is ignored.

If the deceleration rate is too slow for the configured max. time ([AXIS#.SAFEPARAM.SS1_#.TIMETOSTO](#)), the drive will be disabled via STO. The maximum time, normal operating speed, and the deceleration rate should be configured to ensure the drive stops under control before the time expires.

Context

For complete SS1 information refer to (→ # 166).

Versions

Action	Version	Notes
Implemented	02-01-00-000	

General Information

Type	Read/Write
Units	Rotary: RPM/s, RPS/s, deg/s ² , (custom units)/s ² , rad/s ² Linear: counts/s ² , mm/s ² , μm/s ² , (custom units)/s ²
Range	Depends on units.
Default Value	10,000 RPM/s, depends on units.
Data Type	Float
Stored in Non Volatile Memory	Yes

10.8.1.24 AXIS#.SAFE.SS1_#.INTERNALSTATE**Description**

Indicates the internal state of the Safe Stop 1 (SS1) state machine.

SS1-t is executed when the drive is FS2 or “Deceleration & Velocity monitoring” is disabled in the safety parameters.

SS1-r is executed when “Deceleration & Velocity monitoring” is enabled in the safety parameters.

SS1-t		SS1-r	
Value	Description	Value	Description
0	Not Running	0	Not Running
1	Delay Before STO	1	Delay Before Monitoring
		2	Target Velocity Not Reached
		3	Target Velocity Reached
4	STO Activated	4	STO Activated
		5	Fault Reaction

Context

For complete SS1 information refer to (→ # 166).

Versions

Action	Version	Notes
Implemented	02-00-00-000	

General Information

Type	Read Only
Units	N/A
Range	0 to 5
Default Value	0 (Idle)
Data Type	Integer
Stored in Non Volatile Memory	No

10.8.1.25 AXIS#.SAFE.SS1_#.MODE**Description**

Sets the behavior of the drive when the corresponding Safe Stop 1 (SS1) input is triggered.

Value	Description
0	Drive Controlled - Drive performs a controlled stop following AXIS#.SAFE.SS1_#.DEC deceleration rate.
1	Fieldbus Controlled - The drive will not perform any stopping action, the fieldbus master should stop the drive within the configured AXIS#.SS1_#.T amount of time before the drive triggers the STO signal. The manufacturer status object 50EFh is used to signal to the fieldbus master that an SS1 input has been triggered.

Context

For complete SS1 information refer to (→ # 166).

Versions

Action	Version	Notes
Implemented	02-01-00-000	

General Information

Type	Read/Write
Units	N/A
Range	0 to 1
Default Value	0 (Drive Controlled)
Data Type	Integer
Stored in Non Volatile Memory	Yes

10.8.1.26 AXIS#.SAFE.STO.ACTIVE**Description**

Indicates the Safe Torque Off (STO) state of the axis.

Value	Description
1	STO active (inputs +0V)
0	STO inactive (inputs 24V)

Context

For complete STO information refer to "STO (Safe Torque Off)" (→ # 162).

Versions

Action	Version	Notes
Implemented	02-00-00-000	

General Information

Type	Read Only
Units	N/A
Range	0 or 1
Default Value	N/A
Data Type	Integer
Stored in Non Volatile Memory	No

10.8.1.27 AXIS#.SAFE.STO.REPORTFAULT**Description**

This parameter controls whether a Safe Torque Off (STO) fault F9000 will be created when STO is activated while the axis is enabled. The STO warning W9000 is always generated if this parameter is 1 and the STO function is active.

Value	Description
1	W9000 / F9000 are generated when axis is enabled and an STO occurs (default)
0	W9000 / F9000 are not generated

Context

For complete STO information refer to "STO (Safe Torque Off)" (→ # 162).

Versions

Action	Version	Notes
Implemented	02-00-00-000	

General Information

Type	Read/Write
Units	N/A
Range	0 or 1
Default Value	1
Data Type	Integer
Stored in Non Volatile Memory	Yes

10.8.1.28 AXIS#.SAFE.TEMPWARNING.ACTIVE**Description**

Indicates whether the SMM temperature is in the expected range.

Value	Description
0	SMM temperature is not in the expected range
1	SMM temperature is ok

Versions

Action	Version	Notes
Implemented	2-00-00-000	Implemented in SMM revision v0.56

General Information

Type	Read Only
Units	N/A
Range	0, 1
Default Value	N/A
Data Type	Integer
Stored in Non Volatile Memory	No

10.8.1.29 AXIS#.SAFEPARAM.AXISCFGEN**Description**

Indicates whether the axis is enabled in the safety configuration. This parameter is for information only. It is handled automatically when using safety parameters from WorkBench. When using FSoE parameters the defaults are properly filled out based on single or dual axis EtherCAT product codes.

Versions

Action	Version	Notes
Implemented	02-01-02-000	

General Information

Type	Read/Write
Units	N/A
Range	0 or 1
Default Value	N/A
Data Type	Integer
Stored in Non Volatile Memory	No

10.8.1.30 AXIS#.SAFEPARAM.SBC.BRAKETIMEDELAY**Description**

Indicates the delay required to apply the brake.

If the brake is configured without SDB (Safe Dynamic Brake) (brake before STO [Safe Torque Off]), the drive stays energized for the delay time once stopped to hold position and waits for the brake to apply before de-energizing the power stage.

If the brake is configured with SDB (brake simultaneously with STO), the delay time does not have any effect.

To ensure proper brake operation, this parameter should be the same or longer than the AXIS#.MOTOR.TBRAKEAPP time.

NOTICE

Ensure that the delay specified is enough time for the brake to fully engage. If an STO occurs prior to the brake fully engaged and the power stage is disabled, the axis load may fall.

Context

For complete SBC information refer to "SBC (Safe Brake Control)" (→ # 171).

Versions

Action	Version	Notes
Implemented	02-01-02-000	

General Information

Type	Read/Write
Units	ms
Range	1-60,000 ms
Default Value	100 ms
Data Type	Integer
Stored in Non Volatile Memory	No

10.8.1.31 AXIS#.SAFEPARAM.SBC.BRAKE#ATTACHED**Description**

Indicates whether Safe Brake Control (SBC) is enabled on this axis. Axis 1 can have SBC enabled with two assigned brakes. Axis 2 can only have SBC enabled with one brake (ie: BRAKE2ATTACHED cannot be set).

Value	Description
0	No brake configured
1	Brake attached – without SDB (brake is applied before STO occurs according to 10.8.1.30 "AXIS#.SAFEPARAM.SBC.BRAKETIMEDELAY")
2	Brake attached – with SDB (brake is applied after STO occurs)

INFO

If AXIS#.MOTOR.BRAKE and BRAKE#.AXIS indicates no brake is attached to the axis but this safety parameter indicates a brake is attached, a warning will occur.

INFO

It is allowed to have a brake configured on the axis without enabling SBC using AXIS#.MOTOR.BRAKE and BRAKE#.AXIS.

Context

For complete SBC information refer to "SBC (Safe Brake Control)" (→ # 171).

Versions

Action	Version	Notes
Implemented	02-00-00-000	

General Information

Type	Read/Write
Units	N/A
Range	0, 1, 2
Default Value	0
Data Type	Integer
Stored in Non Volatile Memory	No

10.8.1.32 AXIS#.SAFEPARAM.SBC.MUTINGSOURCE**Description**

This parameter allows the user to specify a safe input to bypass Safe Brake Control (SBC) and permit the brake to release regardless of whether SBC is active or not. The feature is referred to as 'SBC Muting' in documentation and WorkBench.

Value	Description
0	Not used
1	Safe input 1
2	Safe input 2
3	Safe input 3
4	Safe input 4
5	Safe dual input 1
6	Safe dual input 2

INFO

If using this feature, make sure it is safe to release the brake and there is not a heavy load being held solely by the brake.

Context

For complete SBC information refer to "SBC (Safe Brake Control)" (→ # 171).

Versions

Action	Version	Notes
Implemented	02-01-02-000	

General Information

Type	Read/Write
Units	N/A
Range	0 or 6
Default Value	N/A
Data Type	Integer
Stored in Non Volatile Memory	No

10.8.1.33 AXIS#.SAFEPARAM.SBT.FUNCTIONACTIVATION**Description**

Indicates whether Safe Brake Test (SBT) can be activated. When ready for activation and SBT has not been run within the specified interval, a warning is activated indicating the need to run SBT. When the SBT is set to never be active, it is not possible to execute the safe brake test and no warning is activated for SBT.

Value	Description
0	Never active
1	Ready for activation

Context

For complete SBT information refer to "SBT (Safe Brake Test)" (→ # 179).

Versions

Action	Version	Notes
Implemented	2-00-00-000	Implemented in SMM revision v0.54

General Information

Type	Read/Write
Units	N/A
Range	0, 1
Default Value	0 (Never active)
Data Type	Integer
Stored in Non Volatile Memory	No

10.8.1.34 AXIS#.SAFEPARAM.SBT.MAXAPPLLOAD**Description**

Specifies the maximum load of the application reflected to the motor shaft converted to current in mA. This value is scalar without regard to direction. It defines the 100% maximum application load. The Safe Brake Test (SBT) is done with 130% of maximum load (current).

Context

For complete SBT information refer to "SBT (Safe Brake Test)" (→ # 179).

Versions

Action	Version	Notes
Implemented	02-01-02-000	

General Information

Type	Read/Write
Units	mA
Range	1 – 200000 mA
Default Value	1000 mA (1 amp)
Data Type	Integer
Stored in Non Volatile Memory	No

10.8.1.35 AXIS#.SAFEPARAM.SBT.MAXMOTIONBRAKE#**Description**

Indicates the amount of rotation that should occur for the shaft attached to the specified brake. If the amount of motion detected is larger than this specified amount, the Safe Brake Test (SBT) will enter a failed state and the Safe Brake Acknowledge (SBA) signal is low.

INFO

The drive will still be allowed to be enabled and command motion. It is up to the safety system to prevent motion in the event of a failed/expired SBT (ie: SBA signal).

Context

For complete SBT information refer to "SBT (Safe Brake Test)" (→ # 179).

Versions

Action	Version	Notes
Implemented	02-01-02-000	

General Information

Type	Read/Write
Units	Arc minutes
Range*	1 to 4294967295 arc minutes
Default Value	300 arc minutes
Data Type	Integer
Stored in Non Volatile Memory	No

*Note: MAXMOTIONBRAKE cannot be set to a greater or equal value than 10800 arcminute. Otherwise, the SMM will return an error code once SBT function is started. The error code can be read by the keyword [AXIS#.SAFE.SBT.ERROR](#), which will report "0x6 – SMM System Error".

10.8.1.36 AXIS#.SAFEPARAM.SBT.MAXTIMEINTERVAL**Description**

Indicates the time in minutes that Safe Brake Test (SBT) must be executed before a warning becomes active that indicates SBT should be run and the Safe Brake Acknowledge (SBA) signal becomes low.

INFO

If the SBT period has elapsed the drive will permit enabling and movement. It is up to the safety system design to prevent motion if required.

Context

For complete SBT information refer to "SBT (Safe Brake Test)" (→ # 179).

Versions

Action	Version	Notes
Implemented	02-01-02-000	

General Information

Type	Read/Write
Units	Minutes
Range	1 – 480 minutes
Default Value	480 minutes
Data Type	Integer
Stored in Non Volatile Memory	No

10.8.1.37 AXIS#.SAFEPARAM.SBT.TORQUEDURATION**Description**

Indicates the duration in milliseconds that current is applied to the motor with the brake applied during the Safe Brake Test (SBT).

Context

For complete SBT information refer to "SBT (Safe Brake Test)" (→ # 179).

Versions

Action	Version	Notes
Implemented	02-01-02-000	

General Information

Type	Read/Write
Units	ms
Range	500 ms to 60000 ms
Default Value	500 ms
Data Type	Integer
Stored in Non Volatile Memory	No

10.8.1.38 AXIS#.SAFEPARAM.SDB.DELAYBEFOREDIAGNOSE**Description**

Indicates the time in milliseconds from the Safe Dynamic Brake (SDB) output is triggered until the digital input is read back and compared.

Context

For complete SDB information refer to "SDB (Safe Dynamic Brake)" (→ # 185).

Versions

Action	Version	Notes
Implemented	02-00-00-000	

General Information

Type	Read/Write
Units	Milliseconds
Range	1 ms to 60,000 ms
Default Value	1 ms
Data Type	Integer
Stored in Non Volatile Memory	No

10.8.1.39 AXIS#.SAFEPARAM.SDB.DELAYBEFORESWITCHING**Description**

Indicates the time in milliseconds from STO being activated until the Safe Dynamic Brake (SDB) relay is energized.

Context

For complete SDB information refer to "SDB (Safe Dynamic Brake)" (→ # 185).

Versions

Action	Version	Notes
Implemented	02-00-00-000	

General Information

Type	Read/Write
Units	Milliseconds
Range	1 ms to 60,000 ms
Default Value	1 ms
Data Type	Integer
Stored in Non Volatile Memory	No

10.8.1.40 AXIS#.SAFEPARAM.SDB.FUNCTIONACTIVATION**Description**

Indicates whether Safe Dynamic Brake (SDB) is ready for activation.

Value	Description
0	Never active
1	Ready for activation

Context

For complete SDB information refer to "SDB (Safe Dynamic Brake)" (→ # 185).

Versions

Action	Version	Notes
Implemented	02-00-00-000	Implemented in SMM revision v0.54

General Information

Type	Read/Write
Units	N/A
Range	0, 1
Default Value	0 (Never active)
Data Type	Integer
Stored in Non Volatile Memory	No

10.8.1.41 AXIS#.SAFEPARAM.SDB.READBACKSOURCE**Description**

Indicates the digital input that is used for the read back input.

Value	Description
0	Not used
1	Safe Input 1
2	Safe Input 2
3	Safe Input 3
4	Sage Input 4
5	Safe dual input 1
6	Safe dual input 2

Context

For complete SDB information, refer to "SDB (Safe Dynamic Brake)" (→ # 185).

Versions

Action	Version	Notes
Implemented	02-00-00-000	

General Information

Type	Read/Write
Units	N/A
Range	0 or 6
Default Value	0 (Not used)
Data Type	Integer
Stored in Non Volatile Memory	No

10.8.1.42 AXIS#.SAFEPARAM.SS1_#.FSOE**Description**

Indicates if the Safe Stop 1 (SS1) function instance can be activated through FSoE. This parameter can only be set to “Used” when FSoE is activated ([SAFEPARAM.SAFEFIELDBUS.ACTIVATION](#) is set to 1 – “Activated”).

Value	Description
0	Not used
1	Used

Context

For complete SS1 information refer to (→ # 166).

Versions

Action	Version	Notes
Implemented	2-00-00-000	Implemented in SMM revision v0.54

General Information

Type	Read/Write
Units	N/A
Range	0, 1
Default Value	0 (Not used)
Data Type	Integer
Stored in Non Volatile Memory	No

10.8.1.43 AXIS#.SAFEPARAM.SS1_#.FUNCTIONACTIVATION**Description**

Indicates how the function can be activated.

Safe Stop 1 (SS1) Instance 1 is always ready for activation (fault reaction).

SS1 Instance 2 and SS1 Instance 3 can be set to one of the two following values:

Value	Description
0	Never active
1	Ready for activation

Context

For complete SS1 information refer to (→ # 166).

Versions

Action	Version	Notes
Implemented	2-00-00-000	Implemented in SMM revision v0.54

General Information

Type	Read/Write
Units	N/A
Range	1 for Instance 1 0, 1 for Instance 2 or 3
Default Value	Instance 1 : 1 (Ready for activation) Instance 2 and 3 : 0 (Never active)
Data Type	Integer
Stored in Non Volatile Memory	No

10.8.1.44 AXIS#.SAFEPARAM.SS1_#.SAFEINPUT**Description**

Indicates which safe input can trigger the Safe Stop 1 (SS1) safety function.

Value	Description
0	Not used
1	Safe Input 1 (SIN1)
2	Safe Input 2 (SIN2)
3	Safe Input 3 (SIN3)
4	Safe Input 4 (SIN4)
5	Safe dual input 1 (SIN1/SIN2)
6	Safe dual input 2 (SIN3/SIN4)

Context

For complete SS1 information refer to (→ # 166).

Versions

Action	Version	Notes
Implemented	2-00-00-000	Implemented in SMM revision v0.54

General Information

Type	Read/Write
Units	N/A
Range	0, 1, 2, 3, 4, 5, 6
Default Value	0 (Not used)
Data Type	Integer
Stored in Non Volatile Memory	No

10.8.1.45 AXIS#.SAFEPARAM.SS1_#.TIMETOSTO**Description**

Indicates the maximum time delay in milliseconds to initiate Safe Torque Off (STO) when SS1 is activated.

Context

For complete SS1 information refer to (→ # 166).

Versions

Action	Version	Notes
Implemented	02-00-00-000	Implemented in SMM revision v0.54

General Information

Type	Read/Write
Units	Milliseconds
Range	[2, 60000]
Default Value	2
Data Type	Integer
Stored in Non Volatile Memory	No

10.8.1.46 AXIS#.SAFEPARAM.STO.FSOE**Description**

Indicates if the Safe Torque Off (STO) function can be activated through FSoE. This parameter can only be set to "Used" when FSoE is activated ([SAFEPARAM.SAFEFIELDBUS.ACTIVATION](#) is set to 1 – "Activated").

Value	Description
0	Not used
1	Used

Context

For complete STO information refer to "STO (Safe Torque Off)" (→ # 162).

Versions

Action	Version	Notes
Implemented	02-00-00-000	Implemented in SMM revision v0.54

General Information

Type	Read/Write
Units	N/A
Range	0, 1
Default Value	0
Data Type	Integer
Stored in Non Volatile Memory	No

10.8.1.47 AXIS#.SAFEPARAM.STO.FUNCTIONACTIVATION**Description**

Indicates how the function can be activated. For Safe Torque Off (STO), the function is ready for activation.

Value	Description
1	Ready for activation

Context

For complete STO information refer to "STO (Safe Torque Off)" (→ # 162).

Versions

Action	Version	Notes
Implemented	02-00-00-000	Implemented in SMM revision v0.54

General Information

Type	Read/Write
Units	N/A
Range	1
Default Value	Axis 1 – 1 (Ready for activation) Axis 2 – 1 (Ready for activation)
Data Type	Integer
Stored in Non Volatile Memory	No

10.8.1.48 AXIS#.SAFEPARAM.STO.RESTARTACKMODE**Description**

Indicates whether the Safe Torque Off (STO) will automatically reset or requires a manual reset using safe input or FSoE. In Automatic Restart mode, when the STO input clears, the STO automatically restarts and the drive is enabled. In Manual Restart mode, when the STO input clears, the STO remains active until the configured input triggers the STO to restart. See 10.8.1.49 "AXIS#.SAFEPARAM.STO.RESTARTACKSOURCE").

Value	Description
0	Automatic Restart (default)
1	Manual Restart

Context

For complete STO information refer to "STO (Safe Torque Off)" (→ # 162).

Versions

Action	Version	Notes
Implemented	02-01-02-000	

General Information

Type	Read/Write
Units	N/A
Range	0 (Automatic Restart) 1 (Manual Restart)
Default Value	0 (Automatic Restart)
Data Type	Integer
Stored in Non Volatile Memory	No

10.8.1.49 AXIS#.SAFEPARAM.STO.RESTARTACKSOURCE**Description**

Indicates the input to use to manually clear the Safe Torque Off (STO) once the STO input is cleared. Only used when the STO is configured for Manual Restart mode (see 10.8.1.48 "AXIS#.SAFEPARAM.STO.RESTARTACKMODE").

Value	Description
0	Not Used
1	Safe Input 1
2	Safe Input 2
3	Safe Input 3
4	Safe Input 4
5	Safe dual input 1
6	Safe dual input 2

Context

For complete STO information refer to "STO (Safe Torque Off)" (→ # 162).

Versions

Action	Version	Notes
Implemented	02-01-02-000	

General Information

Type	Read/Write
Units	N/A
Range	0 or 6
Default Value	0 (Not used)
Data Type	Integer
Stored in Non Volatile Memory	No

10.8.1.50 AXIS#.SAFEPARAM.STO.SAFEINPUT**Description**

Indicates which safety input can trigger the Safe Torque Off (STO) safety function.

Value	Description
0	Not used
1	Safe Input 1 (SIN1)
2	Safe Input 2 (SIN2)
3	Safe Input 3 (SIN3)
4	Safe Input 4 (SIN4)
5	Safe dual input 1 (SIN1/SIN2)
6	Safe dual input 2 (SIN3/SIN4)

Context

For complete STO information refer to "STO (Safe Torque Off)" (→ # 162).

Versions

Action	Version	Notes
Implemented	02-00-00-000	Implemented in SMM revision v0.54

General Information

Type	Read/Write
Units	N/A
Range	0, 1, 2, 3, 4, 5, 6
Default Value	Axis 1 – 5 (Safe Dual In 1) Axis 2 – 6 (Safe Dual In 2)
Data Type	Integer
Stored in Non Volatile Memory	No

10.8.1.51 BRAKE#.SAFE.SBT.ELAPSED**Description**

Returns the elapsed milliseconds since the last successful Safe Brake Test (SBT) on the specified brake. When the returned time reaches the max period defined by the safety parameters [AXIS#.SAFEPARAM.SBT.MAXTIMEINTERVAL](#), the Safe Brake Acknowledgment (SBA) signal is set to low.

Code

```
--> BRAKE1 . SAFE . SBT . ELAPSED
3306031
```

Context

For complete SBT information refer to "SBT (Safe Brake Test)" (→ # 179).

Versions

Action	Version	Notes
Implemented	02-00-00-000	Implemented in SMM revision v0.32

General Information

Type	Read Only
Units	N/A
Range	N/A
Default Value	N/A
Data Type	Integer
Stored in Non Volatile Memory	No

10.8.1.52 BRAKE#.SAFE.SBT.STATE**Description**

Read the state of the Safe Brake Test (SBT) on the specified brake. The return value is one of the following:

Value	Description
0	The brake is not tested.
1	The brake has been successfully tested.
2	The brake failed to test. It may be broken.
3	The brake is applying.
4	The brake is tested.
5	The brake is releasing.

Code

```
--> BRAKE1 . SAFE . SBT . STATE
0
```

Context

For complete SBT information refer to "SBT (Safe Brake Test)" (→ # 179).

Versions

Action	Version	Notes
Implemented	02-00-00-000	Implemented in SMM revision v0.32

General Information

Type	Read Only
Units	N/A
Range	0 - 7
Default Value	N/A
Data Type	Integer
Stored in Non Volatile Memory	No

10.8.1.53 SAFE.CFGERROR**Description**

In case the safety parameters validation fails due to invalid configuration, this parameter returns information about which parameters failed to validate and why.

Code

```
--> SAFE.CFGERROR
```

```
Parameter: [PARAMETER_NUMBER] PARAMETER_KEYWORD_NAME
```

```
Axis: AXIS_ID
```

```
Instance: INSTANCE_ID
```

```
Error: [ERROR_NUMBER] ERROR_DESCRIPTION
```

Context

For information on validation refer to "Validation" (→ # 205).

Versions

Action	Version	Notes
Implemented	02-00-00-000	Implemented in SMM revision v0.32

General Information

Type	Read Only
Units	N/A
Range	N/A
Default Value	N/A
Data Type	String
Stored in Non Volatile Memory	No

10.8.1.54 SAFE.CHANGEPASSWORD**Description**

Change or create the password used for safety parameters operation. The master password remains unchanged and valid. The password must be at least 8 characters long but not more than 25 characters. This password cannot be retrieved if lost but the master password can be used to reset it.

INFO

The master password is SafeMotionMonitorXXX where XXX are the last 3 digits of the drive serial number.

Usage

SAFE.CHANGEPASSWORD <new_password> <confirmation_password>

All parameters are mandatory. The drive will return an error if:

- Not enough parameters are provided .
- Too much parameters are provided .
- At least one of the parameter is out of range.
- The confirmation password is not valid (error returned by the SMM)

INFO

The password strings cannot contain any spaces.

<new_password>: String of 8 bytes min and 25 bytes max

<confirmation_password>: String of 8 bytes min and 25 bytes max

Versions

Action	Version	Notes
Implemented	02-00-00-000	Implemented in SMM revision v0.32

General Information

Type	Command
Units	N/A
Range	N/A
Default Value	N/A
Data Type	N/A
Stored in Non Volatile Memory	No

10.8.1.55 SAFE.CLEARSAFEID**Description**

Clear the SafeID and invalidate the safety parameters. It clears the SafeID and invalidate the safety parameters and in consequence the SMM will go in a safe-state "SafeID not validated" (SAFE.STATE is 2). The SafeID can now be changed using the physical rotary-switches and then the drive must be rebooted to re-validate the SafeID.

Usage

Format is: SAFE.CLEARSAFEID <user_name> <password> <date_and_time>

<user_name>: Username used to perform the safety parameters operation. Max 8 characters.

<password>: Password used for safety parameters operation. Min 8 characters, max 25 characters.

<date_and_time>: Format is YYYY-MM-DDThh:mm:ssZ.

Example: 2019-02-05T16:10:10Z which is 5th of February 2019, 16:10:10 UTC. Time zone must always UTC.

Example: SAFE.CLEARSAFEID john my_password 2019-02-05T16:10:10Z

Context

For information on validation refer to "Validation" (→ # 205).

Versions

Action	Version	Notes
Implemented	02-00-00-000	Implemented in SMM revision v0.32

General Information

Type	Command
Units	N/A
Range	N/A
Default Value	N/A
Data Type	N/A
Stored in Non Volatile Memory	No

10.8.1.56 SAFE.CRC**Description**

Returns the Cyclic Redundancy Check (CRC) of the complete safety parameters file stored in this device. The CRC returned is 0, if there are no safety parameters available.

Bytes 0..3: System CRC

SAFE.CRC is accessible through telnet.

CoE gives the CRC (Index: 0x37C3, SubIndex: 0).

Code

```
--> SAFE.CRC
0x31a564de
```

Context

For information on validation and CRC refer to "Validation" (→ # 205).

Versions

Action	Version	Notes
Implemented	02-00-00-000	Implemented in SMM revision v0.32

General Information

Type	Read Only
Units	N/A
Range	All
Default Value	N/A
Data Type	Integer
Stored in Non Volatile Memory	No

10.8.1.57 SAFE.DEVICECRC**Description**

Returns the Cyclic Redundancy Check (CRC) of the device's safety parameters dedicated to this device stored inside the complete safety parameters file. If there are no safety parameters available, the CRC returned is 0.

Code

```
--> SAFE.DEVICECRC
0x72d5a4df
```

Context

For information on CRC and validation refer to "Validation" (→ # 205).

Versions

Action	Version	Notes
Implemented	02-00-00-000	Implemented in SMM revision v0.32

General Information

Type	Read Only
Units	N/A
Range	All
Default Value	N/A
Data Type	Integer
Stored in Non Volatile Memory	No

10.8.1.58 SAFE.ERROR**Description**

Indicates the current error code of the SMM. Possible values of SAFE.ERROR are:

ID	Failure	Comments
0	No fault	
1	Safe input fault	
2	SDB failure	
3	Safe output fault	
4	STO output fault	
5	Encoder startup timeout	The communication with the encoder reported a fatal problem. The timeout for the startup of the encoder occurred.
6	Encoder fault: No position available	No encoder position is available but is needed. No valid data is available.
7	Power supply fault (Vcc)	Undervoltage led to a reset of the SMM.
8	Black-channel fault	The safe fieldbus detected a failure.
9..11	Fatal faults	No transmission to drive because there is no active communication.
12	Safety parameter invalid	The drive enters a safe state engaging the brake and removing power simultaneously. This happens when the configured sequence is unknown.
13	Brake output fault	
14	Temperature fault	The temperature cools when the drive is switched off.
15	Internal discrepancy	A discrepancy between two micro controllers on the SMM was detected.
16	FPGA not suitable	The FPGA software is not suitable for use with this SMM.
17	Internal fault	Error occurred.
18	IO Fault	Error occurred which can be fixed.
19	Reserved	
20	External memory fault	A failure occurred at the external non-volatile memory.
21	Manufacturing parameter invalid	The manufacturing data is invalid.
22	External discrepancy	The two inputs used for a dual input are different.
23	Brake current fault	The brake current is out of range.
24	Encoder fault: No speed available	No speed is available but is needed. No valid data is available.
25	Encoder fault: Invalid association	The association of the encoder to an axis is invalid. No valid data is available.
26	Encoder fault: Invalid type	The encoder type is invalid. No valid data is available.

Code

```
--> SAFE.ERROR
```

```
0
```

Context

For information on validation refer to "Safety Faults, Safety Warnings" (→ # 209).

Versions

Action	Version	Notes
Implemented	02-00-00-000	Implemented in SMM revision v0.32

General Information

Type	Read Only
Units	N/A
Range	0, 1, 2, 3, 4, 5, 6, 7, 8, 9, 10
Default Value	N/A
Data Type	Integer
Stored in Non Volatile Memory	No

10.8.1.59 SAFE.ERRORINSTANCE**Description**

Indicates the current instance of the error code returned by [SAFE.ERROR](#) (if applicable). The parameter returns 0 when there is no instance or no error. If not, it returns the instance ID (for example, it returns 1 for Axis 1). The instance is dependent on the value returned by [SAFE.ERROR](#). Depending on the context, it could be an Axis ID, Brake ID, encoder ID or Safe I/O ID.

Code

```
--> SAFE.ERRORINSTANCE
1
```

Versions

Action	Version	Notes
Implemented		Implemented in SMM revision v0.53

General Information

Type	Read Only
Units	N/A
Range	N/A
Default Value	N/A
Data Type	Integer
Stored in Non Volatile Memory	No

10.8.1.60 SAFE.ID**Description**

Returns the SafelD of the device. The SafelD returned is 0, if there are no SafelD available. SAFE.ID is accessible through telnet.

Code

```
--> SAFE.ID
0x31
```

Context

For information on validation and CRC refer to "Validation" (→ # 205).

Versions

Action	Version	Notes
Implemented	02-00-00-000	Implemented in SMM revision v0.32

General Information

Type	Read Only
Units	N/A
Range	All
Default Value	N/A
Data Type	Integer
Stored in Non Volatile Memory	No

10.8.1.61 SAFE.IDANDCRC**Description**

Returns the Cyclic Redundancy Check (CRC) and the SafelD of the complete safety parameters file stored in this device. The CRC returned is 0, if there are no safety parameters available.

Bytes 0..3: System CRC

Byte 4: SafelD

SAFE.IDANDCRC is accessible through telnet.

Code

```
--> SAFE.INDANDCRC
0x1031a564de
```

Context

For information on validation and CRC, refer to "Validation" (→ # 205).

Versions

Action	Version	Notes
Implemented	02-00-00-000	Implemented in SMM revision v0.32

General Information

Type	Read Only
Units	N/A
Range	All
Default Value	N/A
Data Type	Integer
Stored in Non Volatile Memory	No

10.8.1.62 SAFE.INVALIDATEPARAMS

Description

Invalidate the safety parameters. This command is executed when the SMM is in "operational" (SAFE.STATE is 6). It will invalidate the safety parameters and in consequence the SMM will go in a safe-state "configuration needed" (SAFE.STATE is 3).

Usage

Format is: SAFE.INVALIDATEPARAMS <user_name> <password> <date_and_time>

<user_name>: Username used to perform the safety parameters operation. Max 8 characters.

<password>: Password used for safety parameters operation. Min 8 characters, max 25 characters.

<date_and_time>: Format is YYYY-MM-DDThh:mm:ssZ.

Example: 2019-02-05T16:10:10Z which is 5th of February 2019, 16:10:10 UTC. Time zone must always be UTC.

Example: SAFE.INVALIDATEPARAMS john my_password 2019-02-05T16:10:10Z

Context

For more information refer to "Validation" (→ # 205) and "Safety Parameter Download" (→ # 200).

Versions

Action	Version	Notes
Implemented	02-00-00-000	Implemented in SMM revision v0.32

General Information

Type	Command
Units	N/A
Range	N/A
Default Value	N/A
Data Type	N/A
Stored in Non Volatile Memory	No

10.8.1.63 SAFE.MONITOR#.AXIS**Description**

Defines the axis of the monitored SMM variable returned by SAFE.MONITOR#.DATA. Two variables can be configured at the same time using SAFE.MONITOR1.AXIS and SAFE.MONITOR2.AXIS.

Code

```
--> SAFE.MONITOR1.AXIS 1
```

Versions

Action	Version	Notes
Implemented	02-00-00-000	Implemented in SMM revision v0.32

General Information

Type	Read/Write
Units	N/A
Range	1 to 2 on dual axis product. 1 on single axis product
Default Value	1
Data Type	N/A
Stored in Non Volatile Memory	No

10.8.1.64 SAFE.MONITOR#.DATA**Description**

Reads the value of the monitored SMM variables. Two variables can be read at the same time using SAFE.MONITOR1.DATA and SAFE.MONITOR2.DATA. The variable to monitor is configured by using SAFE.MONITOR#.SOURCE, SAFE.MONITOR#.AXIS and SAFE.MONITOR#.INSTANCE.

Code

```
--> SAFE.MONITOR1.DATA  
1
```

Versions

Action	Version	Notes
Implemented	02-00-00-000	Implemented in SMM revision v0.32

General Information

Type	Read Only
Units	N/A
Range	N/A
Default Value	N/A
Data Type	Integer
Stored in Non Volatile Memory	No

10.8.1.65 SAFE.MONITOR#.INSTANCE**Description**

Defines the instance of the monitored SMM variable returned by [SAFE.MONITOR#.DATA](#). Two variables can be configured at the same time using SAFE.MONITOR1.INSTANCE and SAFE.MONITOR2.INSTANCE.

Code

```
--> SAFE.MONITOR1.INSTANCE 1
```

Versions

Action	Version	Notes
Implemented	02-00-00-000	Implemented in SMM revision v0.32

General Information

Type	Read/Write
Units	N/A
Range	1 to 4
Default Value	1
Data Type	N/A
Stored in Non Volatile Memory	N/A

10.8.1.66 SAFE.MONITOR#.SOURCE**Description**

Defines the source of the monitored safe variable SAFE.MONITOR#.DATA. Two variables can be configured at the same time using SAFE.MONITOR1.SOURCE and SAFE.MONITOR2.SOURCE. The source can be one of the following values:

Value	Content
1	Current state of the internal state machine of the STO function
2	Current state of the internal state machine of the SS1 function
3	Current state of the internal state machine of the SBC function
4	Current state of the internal state machine of the brake (Axis information is ignored, Two instances for brake 1 and 2 are provided)
5 to 20	reserved, Functional Safety Option 3 only

Code

```
--> SAFE.MONITOR1.SOURCE 2
```

Versions

Action	Version	Notes
Implemented	02-00-00-000	Implemented in SMM revision v0.32

General Information

Type	Read/Write
Description	Source of the monitored SMM variable.
Units	N/A
Range	0 to 20
Default Value	1
Data Type	N/A

10.8.1.67 SAFE.STATE**Description**

SAFE.STATE indicates the current state of the SMM. It's accessible through telnet and through CoE (Index: 0x37C1, SubIndex: 0). The possible values of SAFE.STATE are:

Value	Name	Description
0, 16...254	Invalid	Reserved.
1	Start-up	The SMM is starting up. This will be present, while the connection to the safe fieldbus starts up.
2	SafeID not validated	SafeID is not validated or invalid. Validation process required.
3	Configuration required	A new configuration is required. The configuration of the SMM may be broken.
4	Configuration invalid	The last configuration is invalid and new configuration is required.
5	Parameter validation required	Safety parameters are not validated.
6	Normal operation	The SMM is working normally. In this state, STO or the brake may be active.
7	Safe brake test	A brake test is occurring. The test will be triggered by the drive processor. This state is activated for the complete device, even though only a single axis is tested.
8	IO Failure	The SMM detected a fault that may be acknowledged. During this state STO and the brakes will be active.
9	Internal Failure	Some catastrophic failure occurred. The SMM does not release operation until it was power cycled.

Code

```
--> SAFE.STATE
6
```

Versions

Action	Version	Notes
Implemented	02-00-00-000	Implemented in SMM revision v0.32

General Information

Type	Read Only
Units	N/A
Range	1, 2, 3, 4, 5, 6, 7, 8, 9, 255
Default Value	N/A
Data Type	Integer
Stored in Non Volatile Memory	No

10.8.1.68 SAFE.SWITCH**Description**

Returns a value defined by the state of the two rotary switches S1 and S2. The returned value is equal to $(100 \cdot S1 + S2)$. When this value is validated, it becomes the SafeID.

Code

```
--> SAFE.SWITCH
16
```

Versions

Action	Version	Notes
Implemented	02-00-00-000	Implemented in SMM revision v0.32

General Information

Type	Read Only
Units	N/A
Range	0 or 1
Default Value	N/A
Data Type	Integer
Stored in Non Volatile Memory	No

10.8.1.69 SAFE.VALIDATEPARAM**Description**

Validates the safety parameters. Safety parameters must first be downloaded to the device.

Format is: SAFE.VALIDATE <user_name> <password> <date_and_time> <safe_id>

All parameters are mandatory. The drive will return an error if:

- Not enough parameters are provided
- Too many parameters are provided
- At least one of the parameter is out of range.

Note that the user_name and the password strings cannot contain any spaces.

- <user_name>: String of 8 bytes max
- <password>: String of 8 bytes min and 25 bytes max
- <date_and_time>: In the format defined by the RFC3339. The date must be in the UTC time zone.

Code

```
--> SAFE.VALIDATE john john_password 2019-02-22T10:58:30Z 16
```

Context

For more information refer to "Validation" (→ # 205) and "Safety Parameter Download" (→ # 200).

Versions

Action	Version	Notes
Implemented	02-00-00-000	Implemented in SMM revision v0.32

General Information

Type	Command
Units	N/A
Range	N/A
Default Value	N/A
Data Type	N/A
Stored in Non Volatile Memory	No

10.8.1.70 SAFE.VALIDATIONLOG

Description

Returns logged information about safety parameters validation and SafeID management. First displayed entry is the newest one (Index: 0). 32 entries can be stored at a maximum. Each entry contains:

- A username to indicate who performs the operation. Note that for the SafeID the user validation is done using the push button. Then the user recorded is called HW_BUTTON.
- An information string can be:
 - "PARAM VAL (X, Z)" for safety parameters validation where X is the SafeID and Z is the CRC of the validated safety parameters.
 - "PARAM CLR (X)" for safety parameters invalidation where X is the SafeID.
 - "ID VAL (X)" for SafeID validation where X is the validated SafeID.
 - "ID CLR" for SafeID invalidation.
- A date in the format defined by the RFC3339. The date is always in UTC time zone. No date is recorded when the SafeID is validated (user operation through push button).

Code

--> SAFE.VALIDATIONLOG
0;john;PARAM VAL (16, 0x3F3A0F07);2019-02-18T14:58:55Z
1;rob;PARAM VAL (16, 0x3F3A0F07);2019-02-01T15:19:09Z
2;HW BTN;ID VAL (16);0000-00-00T00:00:00Z
3;john;PARAM CLR (16);2019-01-31T14:39:39Z
4;john;ID CLR;2019-01-31T14:39:39Z
5;john;PARAM VAL (16, 0x3F3A0F07);2019-01-31T14:58:19Z
6;john;PARAM CLR (16);2019-01-31T14:39:39Z

Context

For more information refer to "Validation" (→ # 205).

Versions

Action	Version	Notes
Implemented	02-00-00-000	Implemented in SMM revision v0.32

General Information

Type	Read Only
Units	N/A
Range	N/A
Default Value	N/A
Data Type	String
Stored in Non Volatile Memory	No

10.8.1.71 SAFE.VERIFYFW**Description**

Sets the username, password, and checksum that is used for an SMM firmware update. WorkBench automatically sends this command when using the firmware update dialog window. Once this command is sent, SMM firmware must be sent by HTTP within 30 seconds.

Usage

Format is: SAFE.VERIFYFW <user_name> <password> <checksum>
 <user_name>: Username used to perform the safety firmware update. Max 8 characters. <password>: Password used for safety firmware update. Min 8 characters, max 25 characters. <checksum>: Checksum of the firmware update binary.

Example: SAFE.VERIFYFW john my_password 0xa1878800

Versions

Action	Version	Notes
Implemented	02-00-00-000	

General Information

Type	Command
Units	N/A
Range	N/A
Default Value	N/A
Data Type	N/A
Stored in Non Volatile Memory	No

10.8.1.72 SAFEPARAM.IOFAILUREACKSOURCE**Description**

Indicates which safe input, if any, is configured as the I/O Failure acknowledge source. This parameter is configured using FSoE or WorkBench with advanced parameters selected. When configured, it allows clearing of an I/O Failure warning (W9011) using the configured safety input.

Versions

Action	Version	Notes
Implemented	02-01-02-000	

General Information

Type	Read/Write
Units	N/A
Range	0 or 1
Default Value	0 (No safe input)
Data Type	Integer
Stored in Non Volatile Memory	No

10.8.1.73 SAFEPARAM.SAFEFIELDBUS.ACTIVATION

With this parameter, the user configures if the safe fieldbus can have control of the safety functions. The following table shows the possible settings for the different use cases:

Case	Safety parameter configuration using	Use of FSoE connection	Safe fieldbus activation setting
1	WorkBench	Yes	Activated
2	WorkBench	No	Not activated
3	SRA (FSoE)	Yes	Activated*
4	FoE	Yes	Activated
5	FoE	No	Not activated

*automatically set when the connection is established and no valid safety configuration is present.

INFO

If there is no valid safety configuration, but the FSoE master tries to establish a safety connection **without** SRA parameters, the connection is rejected.

Case 1: If this parameter is activated through safety configuration using WorkBench, the drive expects a FSoE connection and stays in safe state until this connection is successfully established. **Only if this parameter is activated, then** a safety function is allowed to be controlled by FSoE or activated by local safe digital inputs.

Case 2: If this parameter is set to “Not activated” in the safety configuration using WorkBench, safety functions can **only** be activated by local safe digital inputs.

Case 3: If there is no valid safety configuration, this parameter has the value “not activated”. However, if the FSoE master provides valid safety configuration through SRA parameters, the safety function can be assigned to be activated by FSoE or local safe digital inputs and SAFEFIELDBUS.ACTIVATION is set to “Activated”.

Case 4: Same behavior as “case 1”, but the parameter file is downloaded using EtherCAT master.

Case 5: Same behavior as “case 2”, but the parameter file is downloaded using EtherCAT master.

INFO

If a safety function is activated through FSoE, it is required this parameter is set to “Activated” and the parameter “FSoE” of the safety function is set to “Used”, e.g., for the STO-Function the parameter name is “SAFEPARAM.STO.FSOE”. By default, the “FSoE” parameter for all safety function is set to “Not Used”.

Versions

Action	Version	Notes
Implemented	02-01-02-000	

General Information

Type	Read/Write
Units	N/A
Range	0 (Not Activated) or 1 (Activated)
Default Value	0 (Not Activated)
Data Type	Integer
Stored in Non Volatile Memory	No

10.8.1.74 SAFEPARAM.SIN.DISTINCTPULSE**Description**

This setting indicates whether pulses on safe inputs must all be distinct from each other (i.e., offset from each other or different periods).

INFO

This does not disable the check for pulses on safe inputs. It only allows or disallows having the same pulse signal across safe inputs.

Versions

Action	Version	Notes
Implemented	02-01-02-000	

General Information

Type	Read/Write
Units	N/A
Range	0 (Disabled) or 1 (Enabled)
Default Value	0 (Disabled)
Data Type	Integer
Stored in Non Volatile Memory	No

10.8.1.75 SAFEPARAM.SINDUAL#.EN**Description**

Enables dual safe inputs for SIN (Safe INput)1-4.

INFO

The corresponding single safety inputs are not allowed to be used when being used in a dual configuration. Safety functions must be configured with the dual input.

INFO

When enabled, paired inputs must be transitioned together within a certain period or an IO failure warning ("W9011 " (→ # 212)) will occur putting the drive in a safe state.

Context

For more information, see "Safe digital inputs" (→ # 156)

Versions

Action	Version	Notes
Implemented	2-00-02-000	

General Information

Type	Read/Write
Units	N/A
Range	0 (Disabled) or 1 (Enabled)
Default Value	N/A
Data Type	Integer
Stored in Non Volatile Memory	No

10.8.1.76 SAFEPARAM.SOUTDUAL#.EN**Description**

Indicates whether the safe outputs are configured as dual outputs or not. When configured as dual, the paired outputs are triggered together.

Context

For more information, see "Safe digital outputs" (→ # 157)

Versions

Action	Version	Notes
Implemented	02-01-02-000	

General Information

Type	Read/Write
Units	N/A
Range	0 (Disabled) or 1 (Enabled)
Default Value	0 (Disabled)
Data Type	Integer
Stored in Non Volatile Memory	No

10.8.1.77 SAFEPARAM.SOUTDUAL#.SOURCE

Description

When outputs are configured for dual outputs, this controls what safety function will trigger the safe output.

INFO

WorkBench will not allow the user to select this setting unless the corresponding SOUTDUAL# is enabled. See [SAFEPARAM.SOUTDUALx.EN](#).

Value	Description	Value	Description	Value	Description	Value	Description
0x00	Off, no output signal driven	0x13	SLS – Axis 2 Instance 2	0x26	SAR – Axis 2 Instance 1	0x39	SCA – Axis 2 Instance 2
0x01	STO – Axis 1	0x14	SLS – Axis 2 Instance 3	0x27	SAR – Axis 2 Instance 2	0x3A	SCA – Axis 2 Instance 3
0x02	STO – Axis 2	0x15	SSM – Axis 1	0x28	SAR – Axis 2 Instance 3	0x3B	SDB – Axis 1
0x03	SS1 – Axis 1 Instance 1	0x16	SSM – Axis 2	0x29	SLI – Axis 1 Instance 1	0x3C	SDB – Axis 2
0x04	SS1 – Axis 1 Instance 2	0x17	SSR – Axis 1 Instance 1	0x2A	SLI – Axis 1 Instance 2	0x3D	SBC – Axis 1
0x05	SS1 – Axis 1 Instance 3	0x18	SSR – Axis 1 Instance 2	0x2B	SLI – Axis 1 Instance 3	0x3E	SBC – Axis 2
0x06	SS1 – Axis 2 Instance 1	0x19	SSR – Axis 1 Instance 3	0x2C	SLI – Axis 2 Instance 1	0x3F	SBA – Axis 1
0x07	SS1 – Axis 2 Instance 2	0x1A	SSR – Axis 2 Instance 1	0x2D	SLI – Axis 2 Instance 2	0x40	SBA – Axis 2
0x08	SS1 – Axis 2 Instance 3	0x1B	SSR – Axis 2 Instance 2	0x2E	SLI – Axis 2 Instance 3	0x43	Ready signal (always on)
0x09	SS2 – Axis 1 Instance 1	0x1C	SSR – Axis 2 Instance 3	0x2F	SLP – Axis 1 Instance 1	0x45	Restart acknowledge request – Axis 1
0x0A	SS2 – Axis 1 Instance 2	0x1D	SDIp – Axis 1	0x30	SLP – Axis 1 Instance 2	0x46	Restart acknowledge request – Axis 2
0x0B	SS2 – Axis 2 Instance 1	0x1E	SDIp – Axis 2	0x31	SLP – Axis 1 Instance 3	0xFF	Always On
0x0C	SS2 – Axis 2 Instance 2	0x1F	SDIn – Axis 1	0x32	SLP – Axis 2 Instance 1		
0x0D	SOS – Axis 1	0x20	SDIn – Axis 2	0x33	SLP – Axis 2 Instance 2		
0x0E	SOS – Axis 2	0x21	SLA – Axis 1	0x34	SLP – Axis 2 Instance 3		
0x0F	SLS – Axis 1 Instance 1	0x22	SLA – Axis 2	0x35	SCA – Axis 1 Instance 1		
0x10	SLS – Axis 1 Instance 2	0x23	SAR – Axis 1 Instance 1	0x36	SCA – Axis 1 Instance 2		
0x11	SLS – Axis 1 Instance 3	0x24	SAR – Axis 1 Instance 2	0x37	SCA – Axis 1 Instance 3		
0x12	SLS – Axis 2 Instance 1	0x25	SAR – Axis 1 Instance 3	0x38	SCA – Axis 2 Instance 1		

Context

For more information, see "Safe digital outputs" (→ # 157)

Versions

Action	Version	Notes
Implemented	02-01-02-000	

General Information

Type	Read/Write
Units	N/A
Range	0x00-0xFF
Default Value	0x00 (Off)
Data Type	Integer
Stored in Non Volatile Memory	No

10.8.1.78 SAFEPARAM.SOUT#.SOURCE

Description

When outputs are configured for single outputs, this controls what safety function triggers the safe output.

INFO

WorkBench will not allow the user to select this setting if the corresponding output is being used in dual output mode. See [SAFEPARAM.SOUTDUALx.EN](#).

Value	Description	Value	Description	Value	Description	Value	Description
0x00	Off, no output signal driven	0x13	SLS – Axis 2 Instance 2	0x26	SAR – Axis 2 Instance 1	0x39	SCA – Axis 2 Instance 2
0x01	STO – Axis 1	0x14	SLS – Axis 2 Instance 3	0x27	SAR – Axis 2 Instance 2	0x3A	SCA – Axis 2 Instance 3
0x02	STO – Axis 2	0x15	SSM – Axis 1	0x28	SAR – Axis 2 Instance 3	0x3B	SDB – Axis 1
0x03	SS1 – Axis 1 Instance 1	0x16	SSM – Axis 2	0x29	SLI – Axis 1 Instance 1	0x3C	SDB – Axis 2
0x04	SS1 – Axis 1 Instance 2	0x17	SSR – Axis 1 Instance 1	0x2A	SLI – Axis 1 Instance 2	0x3D	SBC – Axis 1
0x05	SS1 – Axis 1 Instance 3	0x18	SSR – Axis 1 Instance 2	0x2B	SLI – Axis 1 Instance 3	0x3E	SBC – Axis 2
0x06	SS1 – Axis 2 Instance 1	0x19	SSR – Axis 1 Instance 3	0x2C	SLI – Axis 2 Instance 1	0x3F	SBA – Axis 1
0x07	SS1 – Axis 2 Instance 2	0x1A	SSR – Axis 2 Instance 1	0x2D	SLI – Axis 2 Instance 2	0x40	SBA – Axis 2
0x08	SS1 – Axis 2 Instance 3	0x1B	SSR – Axis 2 Instance 2	0x2E	SLI – Axis 2 Instance 3	0x43	Ready signal (always on)
0x09	SS2 – Axis 1 Instance 1	0x1C	SSR – Axis 2 Instance 3	0x2F	SLP – Axis 1 Instance 1	0x45	Restart acknowledge request – Axis 1
0x0A	SS2 – Axis 1 Instance 2	0x1D	SDIp – Axis 1	0x30	SLP – Axis 1 Instance 2	0x46	Restart acknowledge request – Axis 2
0x0B	SS2 – Axis 2 Instance 1	0x1E	SDIp – Axis 2	0x31	SLP – Axis 1 Instance 3	0xFF	Always On
0x0C	SS2 – Axis 2 Instance 2	0x1F	SDIn – Axis 1	0x32	SLP – Axis 2 Instance 1		
0x0D	SOS – Axis 1	0x20	SDIn – Axis 2	0x33	SLP – Axis 2 Instance 2		
0x0E	SOS – Axis 2	0x21	SLA – Axis 1	0x34	SLP – Axis 2 Instance 3		
0x0F	SLS – Axis 1 Instance 1	0x22	SLA – Axis 2	0x35	SCA – Axis 1 Instance 1		
0x10	SLS – Axis 1 Instance 2	0x23	SAR – Axis 1 Instance 1	0x36	SCA – Axis 1 Instance 2		
0x11	SLS – Axis 1 Instance 3	0x24	SAR – Axis 1 Instance 2	0x37	SCA – Axis 1 Instance 3		
0x12	SLS – Axis 2 Instance 1	0x25	SAR – Axis 1 Instance 3	0x38	SCA – Axis 2 Instance 1		

Context

For more information, see "Safe digital outputs" (→ # 157)

Versions

Action	Version	Notes
Implemented	02-01-02-000	

General Information

Type	Read/Write
Units	N/A
Range	0x00-0xFF
Default Value	SOUT1, 2, 4 – 0xFF (On) SOUT3 – 0x00 (Off)
Data Type	Integer
Stored in Non Volatile Memory	No

10.8.1.79 SINDUAL#.STATE**Description**

Reads the state of one safe dual digital input according to the number identified in the command. The safe dual input is composed of two physical safe inputs. The configuration of the safe dual input is determined by the safety parameters.

Usage

The state of the safe dual input is determined by the state of the two underlying safe inputs.

SIN1.STATE	SIN2.STATE	SINDUAL1.STATE
0	0	0
1	0	I/O failure
0	1	I/O failure
1	1	1

When dual channel mode is selected the drive supervises if the two inputs are in a different state for longer than 100 ms. If this occurs, an I/O failure fault is generated and the drive is put in safe-state.

Context

For more information, see "Safe digital inputs" (→ # 156)

Versions

Action	Version	Notes
Implemented	02-00-00-000	Implemented in SMM revision v0.32

General Information

Type	Read Only
Units	N/A
Range	0 or 1
Default Value	N/A
Data Type	Integer
Stored in Non Volatile Memory	No

10.8.1.80 SIN#.STATE**Description**

SIN1 to SIN4. Reads the state of one safe digital input according to the number identified in the command.

Context

For more information, see "Safe digital inputs" (→ # 156) and "OSSD" (→ # 158)

Versions

Action	Version	Notes
Implemented	02-00-00-000	Implemented in SMM revision v0.32

General Information

Type	Read Only
Units	N/A
Range	0 or 1
Default Value	N/A
Data Type	Integer
Stored in Non Volatile Memory	No

10.8.1.81 SOUTDUAL#.STATE**Description**

Reads the state of one safe dual digital output according to the number identified in the command. The safe dual output is composed of two physical safe outputs. The configuration of the safe dual output is determined by the safety parameters.

Usage

When dual channel mode is selected, the drive drives the two selected safe outputs as they were one safe output.

SOUT1.STATE	SOUT2.STATE	SOUTDUAL1.STATE
0	0	0
1	0	N/A
0	1	N/A
1	1	1

Context

For more information, see "Safe digital outputs" (→ # 157)

Versions

Action	Version	Notes
Implemented	02-00-00-000	Implemented in SMM revision v0.32

General Information

Type	Read Only
Units	N/A
Range	0 or 1
Default Value	N/A
Data Type	Integer
Stored in Non Volatile Memory	No

10.8.1.82 SOUT#.STATE**Description**

SOUT1 to SOUT4. Reads the state of one safe digital output according to the number identified in the command.

Context

For more information, see "Safe digital outputs" (→ # 157)

Versions

Action	Version	Notes
Implemented	02-00-00-000	Implemented in SMM revision v0.32

General Information

Type	Read Only
Units	N/A
Range	0 or 1
Default Value	N/A
Data Type	Integer
Stored in Non Volatile Memory	No

11 Approvals

NOTICE If the drive is labeled Beta, approvals are pending.

11.1 Conformance with UL/cUL	277
11.2 Conformance with CE	278
11.3 Conformance with EAC	279

11.1 Conformance with UL/cUL

This drive is listed under UL (Underwriters Laboratories Inc.) file number **E141084**.

USL, CNL – Power conversion equipment (NMMS, NMMS7)

USL (United States Standards - Listed): Indicates Investigated to United States Standard for Power Conversion Equipment, UL 61800-5-1.

CNL (Canadian National Standards - Listed): Indicates investigation to Canadian Standard for Industrial Control Equipment, CAN/CSA - C22.2, No. 274-17.

UL Markings / Marquages UL

English	Français
<ul style="list-style-type: none"> ● Integral solid state short circuit protection does not provide branch circuit protection. Branch circuit protection must be provided in accordance with the National Electrical Code and any additional local codes. 	<ul style="list-style-type: none"> ● Une protection de court-circuit à semi-conducteur intégrale ne fournit pas de protection de la dérivation. Il convient de garantir une protection de la dérivation conforme au NEC et aux réglementations locales en vigueur.
<ul style="list-style-type: none"> ● This product is suitable for use on a circuit capable of delivering not more than 10 kA rms symmetrical (when protected by class J fuses or circuit breakers). 	<ul style="list-style-type: none"> ● Ce produit est conçu pour une utilisation sur un circuit capable de fournir maximum 10 kArms symétriques (s'il dispose de fusibles classe J ou disjoncteurs).
<ul style="list-style-type: none"> ● Use recommended class J fuses or circuit breaker with SCCR rating not less than 10 kA, 30 A maximum . 	<ul style="list-style-type: none"> ● Utilisez fusibles de classe J ou disjoncteurs recommandés ayant une SCCR d'au moins 10 kA, 30 A maximum .
<ul style="list-style-type: none"> ● Suitable for motor group installation on a circuit capable of delivering not more than 10 kA rms symmetrical. 	<ul style="list-style-type: none"> ● Convient pour une installation de groupe moteur sur un circuit capable de délivrer pas plus de 10 kArms symétriques.
<ul style="list-style-type: none"> ● These drives provide solid state motor overload protection at 125% of the rated FLA current. The drive overload trip point should not be set to less than 10% above the motor rated current: $AXIS\#.IL.FOLDFTHRESHU \geq 1.1 * AXIS\#.MOTOR.ICONT.$ 	<ul style="list-style-type: none"> ● Ces variateurs offrent une protection contre les surcharges de moteur à semi-conducteur à 125 % du courant FLA nominal. Le point de déclenchement en surcharge du variateur ne doit pas être réglé à moins de 10% au dessus du courant nominal du moteur: $AXIS\#.IL.FOLDFTHRESHU \geq 1,1 * AXIS\#.MOTOR.ICONT.$
<ul style="list-style-type: none"> ● These devices are intended to be used in a pollution degree 2 environment and must be placed in an enclosure with min. size of 16 x 16 x 10 inches 	<ul style="list-style-type: none"> ● Ces appareils sont prévus pour une utilisation dans un environnement de pollution de niveau 2 et doivent être placés dans une enceinte avec min. taille de 406 x 406 x 254 mm
<ul style="list-style-type: none"> ● Surrounding air temperature 40°C. Refer to chapter "Ambient Conditions", for other temperature ratings. 	<ul style="list-style-type: none"> ● La température de l'air ambiant 40 °C. Voir chapitre "Ambient Conditions", pour connaître les autres températures.
<ul style="list-style-type: none"> ● Use minimum 75°C copper wire. 	<ul style="list-style-type: none"> ● Utilisez un fil en cuivre 75 °C minimum.
<ul style="list-style-type: none"> ● Connector X3 torque requirements: - screw terminals, tightening torque 4.4 to 5.3 inlbs - locking screw, tightening torque 4.4 inlbs 	<ul style="list-style-type: none"> ● Exigences de couple du connecteur X3: - bornes à vis, couple de serrage 0,5 à 0,6 Nm - vis de blocage, couple de serrage 0,5 Nm
<ul style="list-style-type: none"> ● CAUTION Risk of Electrical Shock! Capacitors can have dangerous voltages present up to five minutes after switching off the supply power. For increased safety, measure the voltage in the DC bus link and wait until the voltage is below 50 V. 	<ul style="list-style-type: none"> ● ATTENTION: Risque de choc électrique! Des tensions dangereuses peuvent persister dans les condensateurs jusqu'à cinq minutes après la mise hors tension. Pour plus de sécurité, mesurez la tension dans la liaison de bus CC et attendez qu'elle soit inférieure à 50 V.

11.2 Conformance with CE

NOTE

EU Declarations of Conformity can be found on the Kollmorgen website.

The drives have been tested by an authorized testing laboratory in a defined configuration, using the system components that are described in this documentation. Any divergence from the configuration and installation described in this documentation means that the user will be responsible for carrying out new measurements to ensure conformance with regulatory requirements.

Kollmorgen declares the conformity of the product series AKD2G with the following directives:

- EC Directive 2006/42/EU, Machinery Directive
Used harmonized standard EN 61800-5-2
- EC Directive 2014/35/EU, Low Voltage Directive
Used harmonized standard EN 61800-5-1
- EC Directive 2014/30/EU, EMC Directive
Used harmonized standard EN 61800-3

NOTICE

These devices can cause high-frequency interferences in non industrial environments and may require measures for interference suppression (such as additional external EMC filters).

Maximum distance for unshielded I/O lines is 3 m inside the cabinet. If the I/O cable leaves the cabinet, it must be EMC shielded.

AKD2G-Sxx-6Vxx

NOTE

AKD2G-Sxx-6Vxx drives do not have integrated ac line EMC filters. External mains filters are described in the *Accessories Manual* (1~: FN2090, 3~: FN3288).

With external EMC mains filters for noise emission the AKD2G-Sxx-6Vxx meet the noise immunity requirements of the second environmental category (industrial environment).

- Motor cable < 10 m: use filter FN 3288 in industrial environment, category C2.
- Motor cable ≥ 10 m: use filter FN 3288 in industrial environment, category C3.

AKD2G-Sxx-7Vxx

NOTE

AKD2G-Sxx-7Vxx drives have integrated EMC filters.

The AKD2G-Sxx-7Vxx meet the noise immunity requirements to the 2nd environmental category (industrial environment).

- Motor cable < 10 m: no filter, in industrial environment, category C3.
- Motor cable < 10 m: use filter FN 3288 in industrial environment, category C2.
- Motor cable ≥ 10 m: use filter FN 3288 in industrial environment, category C2.

11.2.1 Functional Safety approval

NOTE

TÜV Certificate for Functional Safety can be found on the Kollmorgen website.

Kollmorgen offers 3 levels of functional safety implementation for AKD2G:

- Functional Safety Option 1: STO; SIL2 PLd , safe digital I/O command.
- Functional Safety Option 2: STO, SS1-t, SBC, SBT, SDB; SIL3 PLe (→ # 149), safe digital I/O command or FSoE.
- Functional Safety Option 3: STO, SS1-t, SS1-r, SS2, SOS, SLS, SSM, SSR, SDI, SLA, SAR, SLI, SLP, SCA, SBC, SDB, SBT; SIL3 PLe , safe digital I/O command or FSoE.

This manual is valid for AKD2G drives with Functional Safety Option 2.

11.2.2 Conformance with RoHS

The device is manufactured in conformance with RoHS Directive 2011/65/EU with delegated directive 2015/863/EU for installation into a machine.

11.2.3 Conformance with REACH

EU Regulation no. 1907/2006 deals with the registration, evaluation, authorization and restriction of chemical substances 1 (abbreviated to "REACH").

The device does not contain any substances (CMR substances, PBT substances, vPvB substances and similar hazardous substances stipulated in individual cases based on scientific criteria) above 0.1 mass percent per product that are included on the candidate list.

11.3 Conformance with EAC

EAC is the abbreviation for Eurasian Conformity. The mark is used in the states of the Eurasian Customs Union (Russia, Belarus, Kazakhstan) similar to the European CE mark.

Kollmorgen declares, that the device has passed all required conformity procedures in a member state of the Eurasian Customs Union, and that the device meets all technical requirements requested in the member states of the Eurasian Customs Union:

- Low voltage (TP TC 020/2011)
- Electromagnetic Compatibility (TP TC 004/2011)

Contact: SERVOSTAR LLC. , Bld.1, Semyonovskaya nab. 2/1, RU-105094 Moskau

--- / ---

12 Index

A

Abbreviations	14, 145
Address	
Fieldbus	127
FSoE	128
MAC	127
SafeID	128
Service IP	127
AKD 2G Family	31
Ambient Conditions	33
Analog setpoints	114
Aux. supply 24V, interface	81

B

Brake Requirements (FS)	161
--------------------------------------	------------

C

Cable and Wire Requirements	52
Cable Length	52
CANbus	
Baud rate	109
Cable	107
CANopen interface	107
Node address	109
Termination	109
Commissioning	147
Conformance	
CE	278
EAC	279
Functional Safety	279
REACH	279
RoHS	279
UL, cUL	277
Connector Position	60

D

DC Bus Capacitance	40
DC bus link, interface	82
Decommission	25
Dimensions	47
Disassemble	25
Display	41
Disposal	26
Document revisions	283
DSL	86
Dynamic Drive Braking	39

E

EAC	279
Electronic Gearing	103
Emergency Off	21

Emergency Stop Function	21
Emulated Encoder Output	101
Enclosure (FS)	146
Encoder emulation, interface	101
EtherCAT	104
EtherNet	
Modbus TCP Protocol	111
EtherNet Fieldbus	104
EtherNet/IP	106

F

Factory Default Setting	157
Fault messages	140
Feedback Connection	94
Field replacement (FS)	208
FSoE Node Address	192
Functional Safety (FS)	142
Functional Safety 2 (FS2)	149
Fusing	
24V supply	81
Brake resistor	84
DC Bus Link	82
Mains supply	77

G

Grounding	50
Grounding Plates	59

H

Hardware requirements WorkBench	131
Hiperface DSL	86

I

I/O Connection	112
Initial Drive Test	126
Inputs	
Analog	114
Basic Data	113
Digital	116

Installation

Electrical	48
Mechanical	45
Software WorkBench	132
Installation, Setup, Normal Operation	25
Instances	192

L

Leakage current	20
------------------------------	-----------

M

Mains supply, interface	73
Maintenance	25
Master-Slave	103
Mating Connectors	51
Mechanical Data	33

Modbus	111	Safety Warnings	209
Motor dual cable connection	88	SBC	171
Motor Holding Brake Connection	91	SBT	179
Motor interface	84	SD Card Slot	44
Motor single cable connection	85	SDB	185
N		Service Interface	110
Nameplate	28	Setup	125
O		Setup Software	130
Operating systems WorkBench	131	SFA	100
Operation (FS)	207	SFD3	86
Operation States (FS)	208	Shield connection	56
OSSD	158	Shielding	50
Outputs		Shock-hazard protection	20
Analog	115	Site	33
Basic Data	113	SS1-t	166
Digital	120	STO	162
Relay	123	Stop Function	21
P		Switch-on, switch-off behavior	133
Package supplied	28	Symbols used	13
Part Number Scheme	29	T	
PC connection	110	Tightening torque	
Product Safety	15	X1, X2	66
PROFINET	105	X23	71
Prohibited Use		X3	66
Functional Safety	144	X41	72
General	19	Trouble Shooting	141
Pushbuttons	41	U	
R		UL Markings	277
Re-forming	125	Use as directed	
REACH	279	Drive	18
Regen circuit	39	Functional Safety	144
Regen resistor	84	WorkBench Setup Software	130
Regeneration Braking	39	V	
Relay	123	Validation (FS)	205
Repair	26	Ventilation	33
RoHS	279	W	
Rotary Switches	43	Warning Messages	140
S		Warning note labels	19
SafeID	191	Wiring	51
Safety			
Functional Safety	142		
Product Safety	15		
Safety Faults	209		
Safety Instructions			
Drive Setup	125		
Electrical Installation	49		
General	16		
Mechanical Installation	46		
Safety Parameter Download	200		
Safety Properties	150		

13 Record of document revisions

Edition	Remarks
A, 05/2021	First edition

13.1 Limitations

SMM FW	Limitation	Remarks	Solved in SMM FW
1.04	Multiple devices per safety group	Limited to 1 device for FS2 safety groups. Workaround: -	
1.04	SBC with dual brake on single axis drive with FSoE SRA parameters	Configuration of two brakes with SBC on a single axis drive using FSoE SRA parameters is rejected. Workaround: Use Kollmorgen WorkBench safety parameters (which can be downloaded through fieldbus) instead of FSoE SRA parameters	
1.04	SS1 active signal in the FSoE status word	The FSoE status word will return SS1 selected instead of SS1 active. Workaround: Map SS1 active to a safe digital output	
1.04	SafeID validation via FSoE does not invalidate persistent safety parameters	It is possible to validate the SafeID though FSoE when using FSoE SRA parameters. Due to some limitations validation may not clear the existing persistent parameters. Workaround: -	
1.04	Do not use distinct test pulses	Due to some limitations, it is advised to not use the feature "Distinct Pulse Monitoring" and to disable it in the parameters editor (Common / Inputs). Workaround: -	
1.04	EnDat 2.2 is not supported	Any safety configuration containing EnDat 2.2 as a safe encoder will be rejected. Workaround: Use HIPERFACE DSL encoder only	
1.04	Default value of the position increment in user unit is 360 instead of 3600 with FSoE SRA parameters	When using FSoE SRA parameters, the default value of the position increment in user unit is 360 while the position factor unit default value is "deci" and the position user unit is "Degree". Workaround: set position increment in user unit to 3600	
1.04	SLI: Configuration with s_LL_SLI bigger than s_UL_SLI gets rejected	It is not possible to set s_LL_SLI bigger than s_UL_SLI. These configurations get rejected by the safety module. Workaround: -	
1.04	SS2: SOS velocity monitoring is required by SS2	The parameter n_Zero_SOS is required by SS2. It is used by the SS2 velocity monitoring to activate SOS when the axis is ready. Workaround: Set the velocity monitoring of SOS to enabled and set the value of n_Zero_SOS to match the expected behavior (usually to a value bigger than zero).	
1.04	With FSoE parameters, the Axis 1 "SDIn moving" safe signal cannot be mapped to a SOUT.	Note that the SDIn Moving signal of Axis 1 can still be linked to the FSoE status word. Workaround: use Workbench parameters..	
1.04	SDB function with vertical load	Vertical load might fall under certain conditions while enable/disable power stage by SDB function. Workaround: -	

About KOLLMORGEN

Kollmorgen is a leading provider of motion systems and components for machine builders. Through world-class knowledge in motion, industry-leading quality and deep expertise in linking and integrating standard and custom products, Kollmorgen delivers breakthrough solutions that are unmatched in performance, reliability and ease-of-use, giving machine builders an irrefutable marketplace advantage.



Join the [Kollmorgen Developer Network](#) for product support. Ask the community questions, search the knowledge base for answers, get downloads, and suggest improvements.

North America

KOLLMORGEN

201 West Rock Road
Radford, VA 24141, USA

Web: www.kollmorgen.com
Mail: support@kollmorgen.com
Tel.: +1 - 540 - 633 - 3545
Fax: +1 - 540 - 639 - 4162

Europe

KOLLMORGEN Europe GmbH

Pempelfurtstr. 1
40880 Ratingen, Germany

Web: www.kollmorgen.com
Mail: technik@kollmorgen.com
Tel.: +49 - 2102 - 9394 - 0
Fax: +49 - 2102 - 9394 - 3155

South America

KOLLMORGEN

Avenida João Paulo Ablas, 2970
Jardim da Glória, Cotia – SP
CEP 06711-250, Brazil

Web: www.kollmorgen.com
Mail: contato@kollmorgen.com
Tel.: +55 11 4615-6300

China and SEA

KOLLMORGEN

Room 302, Building 5, Lihpao Plaza,
88 Shenbin Road, Minhang District,
Shanghai, China.

Web: www.kollmorgen.cn
Mail: sales.china@kollmorgen.com
Tel.: +86 - 400 668 2802
Fax: +86 - 21 6248 5367