

GSZ series

GSZ series screw jacks are designed for applications where smooth surfaces are required. These screw jacks are easier to clean and therefore ideal for applications in the food processing industry.

Smooth surface

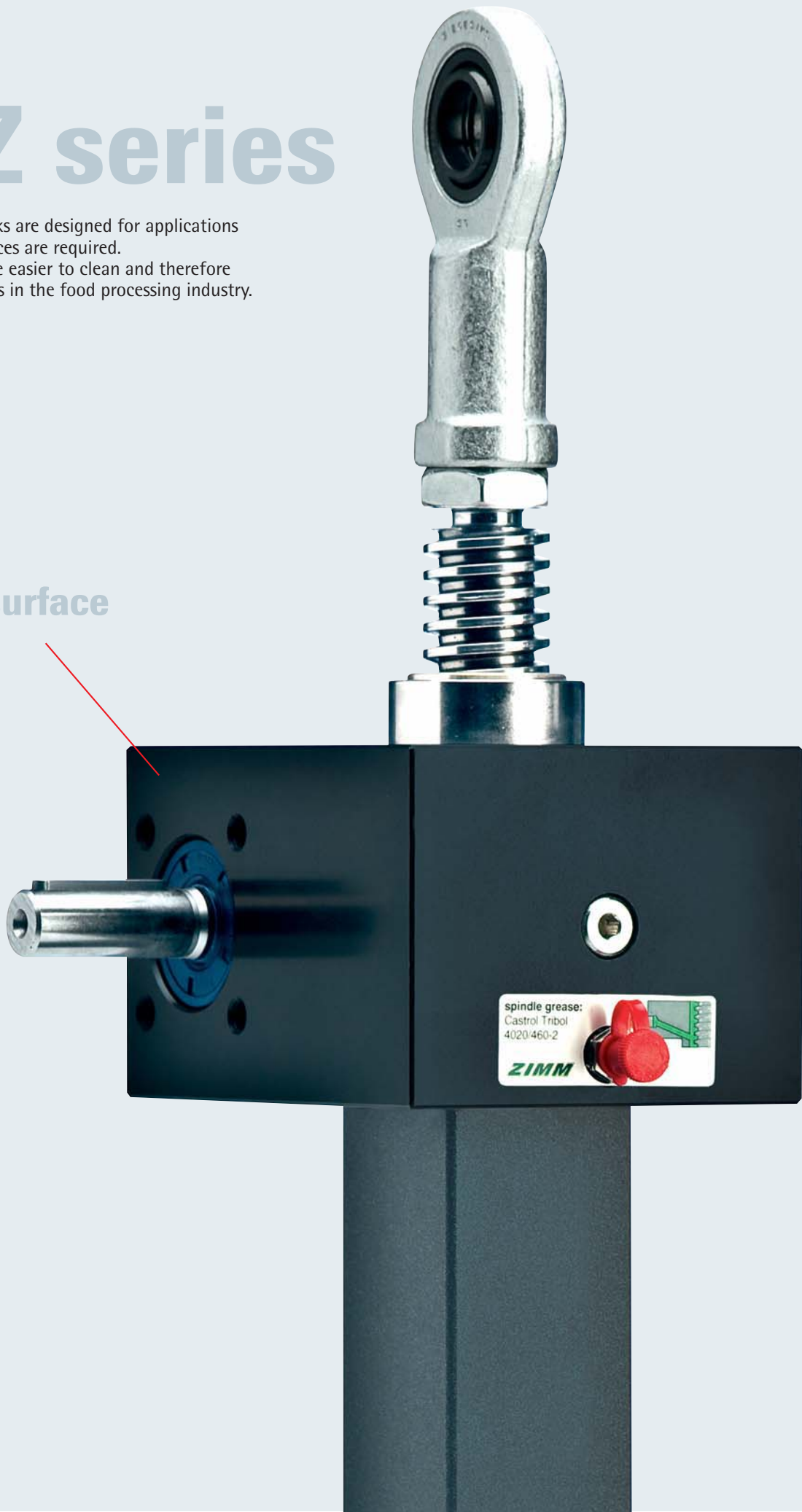

Types and sizes

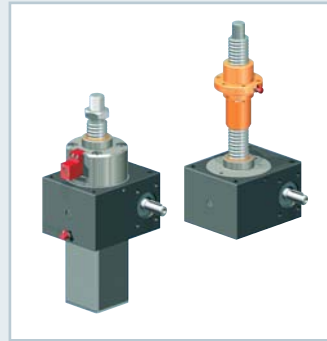
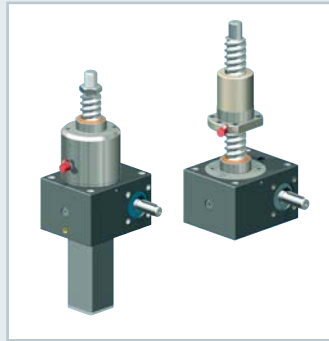
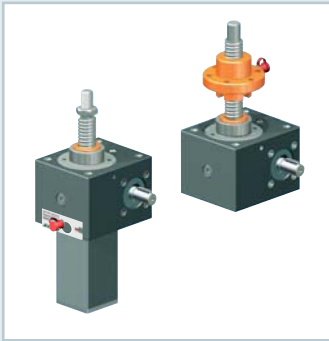

GSZ series jacks Tr
Trapezoidal screw
2.5 kN to 100 kN

Pages 58 - 69



GSZ series jacks KGT
Ball screw
2.5 kN to 100 kN

Pages 70 - 73



GSZ series jacks SIFA
Safety nut
2.5 kN to 100 kN

Pages 74 - 79





UNIQUE:
Screw lubrication
during operation

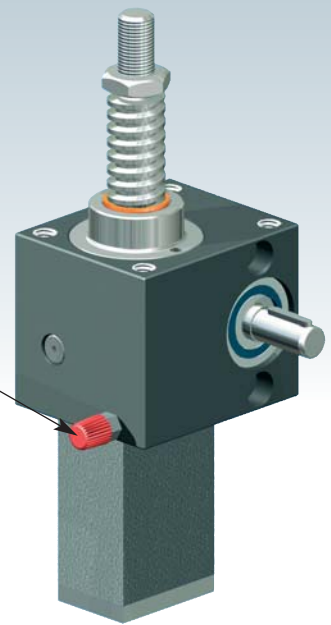

GSZ-2-S translating screw 2.5 kN

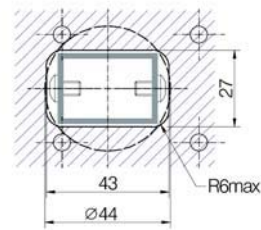
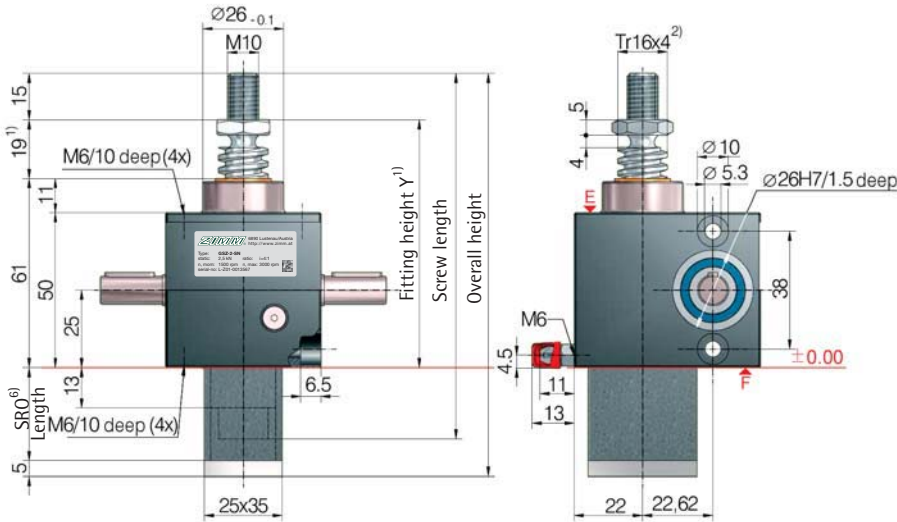

Opening for protective tube SRO, rectangular 43x27 or round Ø 44

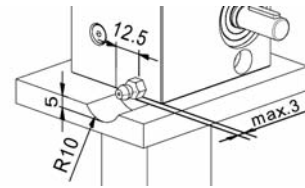

Minimum space requirement for greasing the screw (grease gun)

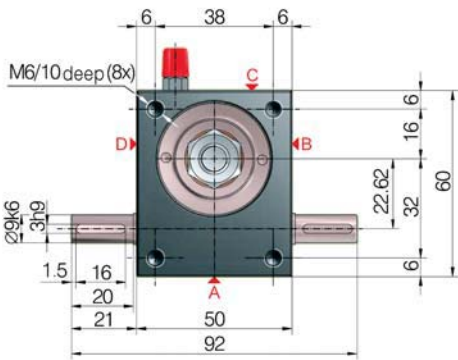

Fitting height "Y" for 0-stroke, with Tr 16x4 screw

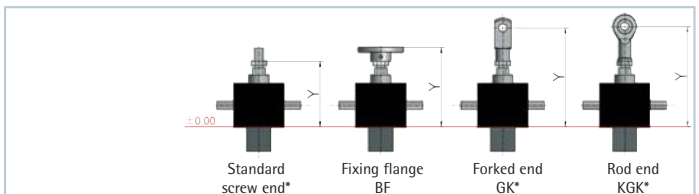

All dimensions in mm

Bellogs FB	Y	Y	Y	Y
without bellogs FB	80	96	120	123
GSZ-2-FB-182	117	116	157	160
GSZ-2-FB-364	177	176	217	220

*with bellogs fixing ring Z-2-FBR

Protective tube length SRO with Tr 16x4 screw

Without escape/ rotation protection	Escape/ rotation protection	Rotation protection, with limit switch set ES	Rotation protection with ES and KAR*
47+stroke	62+stroke	117+stroke	139+stroke

*Hinged bearing plate KAR, fitted on face F (below).

Standard ratios

Type	Version	Speed	Standard screw ²⁾	i	Stroke per drive shaft rotation ⁵⁾
GSZ-2-SN	Translating screw	Normal	Tr 16x4	4:1	1.00 mm
GSZ-2-SL		Low speed		16:1	0.25 mm
GSZ-2-RN	Rotating screw	Normal	Tr 16x4	4:1	1.00 mm
GSZ-2-RL		Low speed		16:1	0.25 mm

Screw jack mounting

- max. load: 2.5 kN compressive and tensile load
- Screw: M6, strength class 8.8
- Screw-in depth: 8 to 10 mm
- Tightening torque: 8 Nm
- Screw locking: with Loctite 243

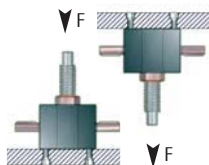

Duty cycle thermal limit, for S+R

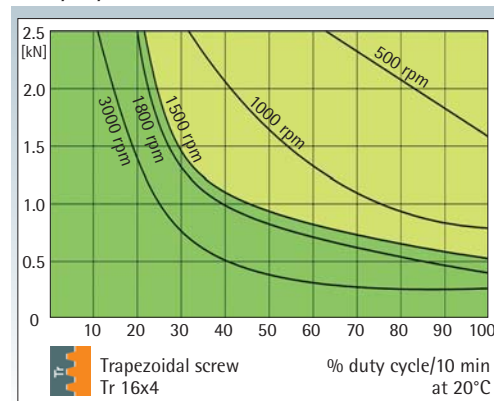

These curves are for guidance under standard industrial conditions (ambient temperature etc.) and correct maintenance (lubrication etc.). The max. input drive torques for optimum service life are at the right page - technical data (1500 rpm)

KGK: % duty cycle 2 times to 4 times higher

Trapezoidal screw

Tr



GSZ-2-R rotating screw 2.5 kN

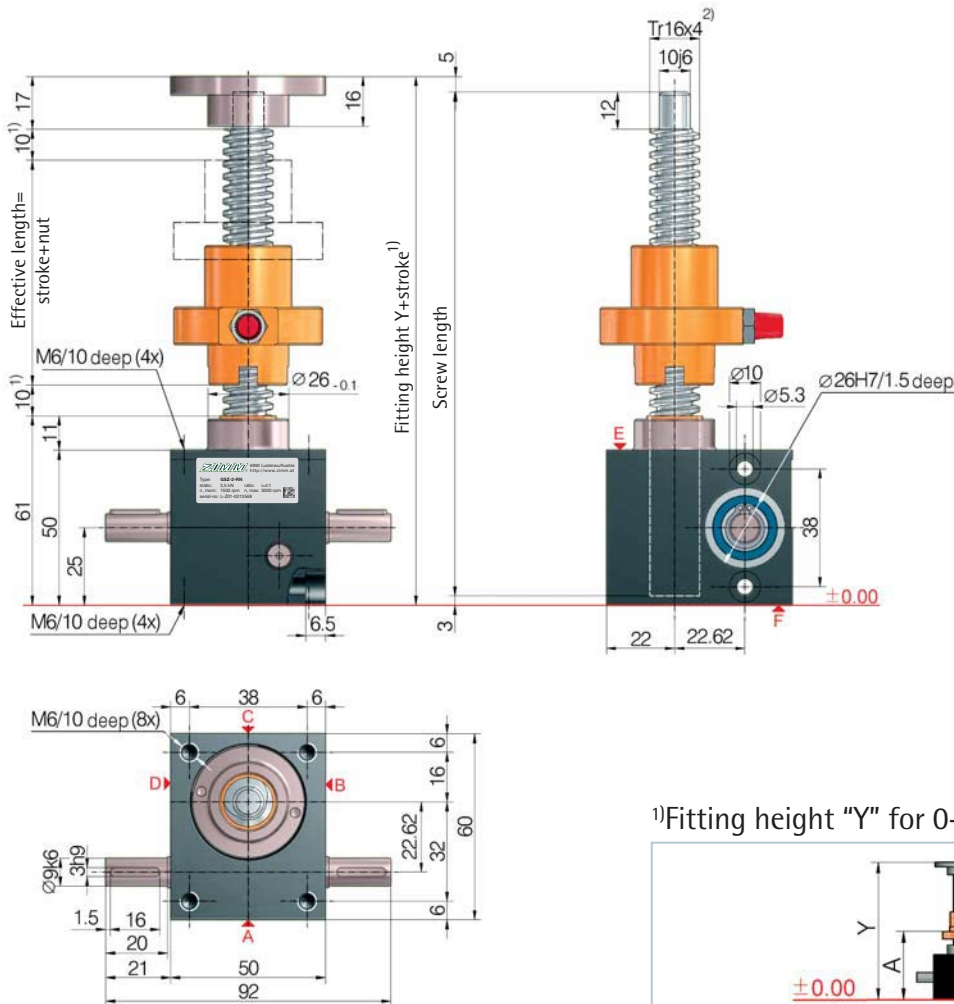
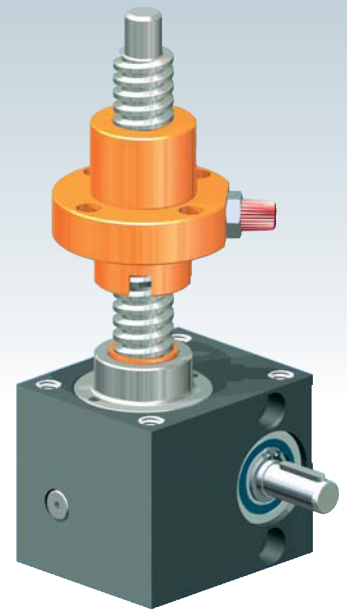

¹⁾Fitting height "Y" for 0-stroke, with Tr 16x4 screw

All dimensions in mm	Flange nut FM	Duplex nut DM	Duplex nut DM with SIFA
Bellows FB	Y/A	Y/A	Y/A
without bellows FB	132/83	142/96	167/121
2x GSZ-2-FB-182	-	198/124	220/146
2x GSZ-2-FB-364	-	318/184	340/206

Detailed instructions for determining the length can be found in Section 8

2.5 kN

Technical data series GSZ-2-S / GSZ-2-R

max. compressive/tensile force, static	- 2.5 kN (250 kg)
max. compressive/tensile force, dynamic	- see duty cycle curves
Nominal speed	- 1500 rpm
max. drive shaft speed	- 3000 rpm (depending on the load and duty cycle)
Screw size standard	- Tr 16x4 ²⁾
Gear ratio	- 4:1 (N) / 16:1 (L)
Housing material	- aluminium, corrosion-resistant
Worm shaft	- stainless steel, ground
Weight of screw jack body	- 0.6 kg
Weight of screw/m	- 1.21 kg
Gearbox lubrication	- synthetic fluid grease
Screw lubrication	- grease lubrication
Gearbox operating temperature	- max. 60°C, higher on request
Moment of inertia	- N: 0.081 kg cm ² / L: 0.037 kg cm ²
Input torque (at 1500 rpm)	- max. 1.4 Nm (N) / max. 0.5 Nm (L)
Drive-through torque	- max. 9 Nm

Drive torque M_6 (Nm)	- F (kN) \times 0.52 ³⁾⁵⁾ + M_L (N-normal)
Breakaway torque	- F (kN) \times 0.15 ³⁾⁵⁾ + M_L (L-low speed)
Idling torque ⁴⁾ M_L (Nm)	- Drive torque M_6 \times 1.5
	- 0.08 (N-normal) / 0.06 (L-low speed)

Between gearbox and nut or nut and end of thread, provide for a safety distance of (minimum) 10 mm!

See Section 7 for the checklist.

Important information

- 1) - extension if a bellows is fitted: see the table or Section 8
- 2) - Tr 16x4 is standard, also available: double-pitch, stainless steel, left-handed, increased screw Tr 18x4 (only for the R version)
- 3) - factor includes efficiency, ratio and 30% safety
- 4) - at 20°C, can be higher when new
- 5) - for a 4 mm screw pitch

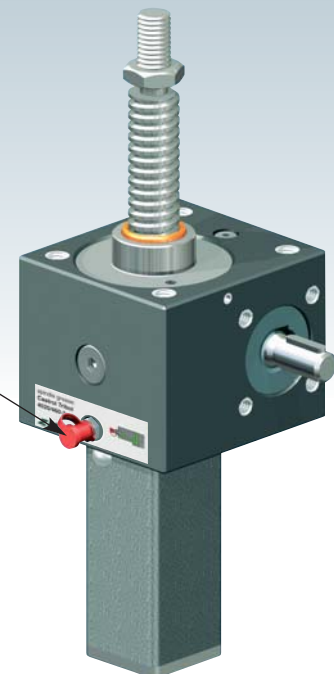

UNIQUE:
Screw lubrication
during operation

GSZ-5-S translating screw 5 kN

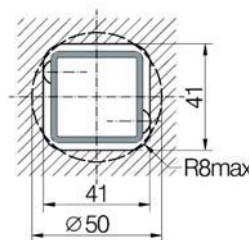
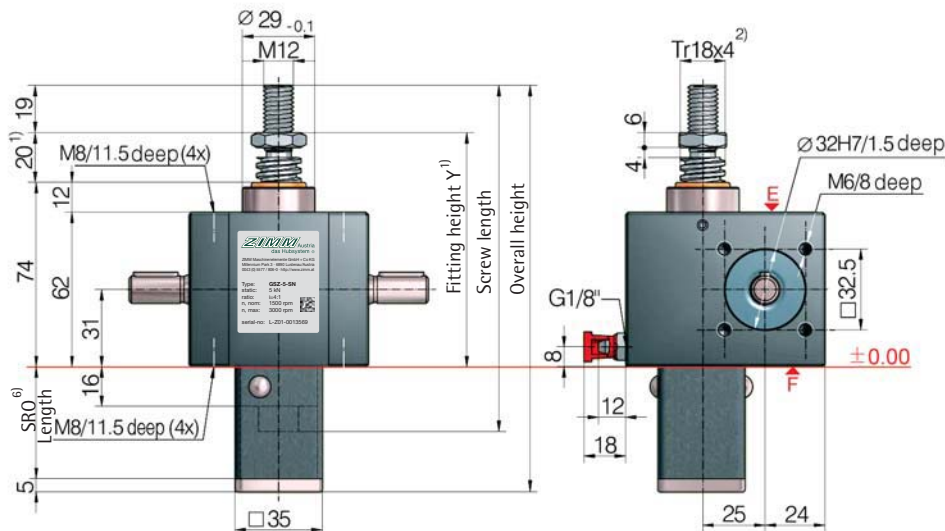

Opening for
protective tube SRO,
square 41x41 or
round Ø 50

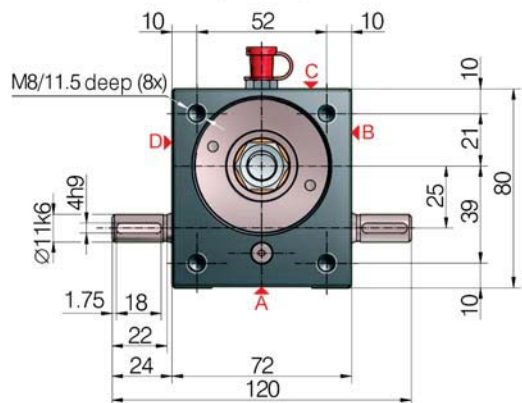

1) Fitting height "Y" for 0-stroke, with Tr 18x4 screw

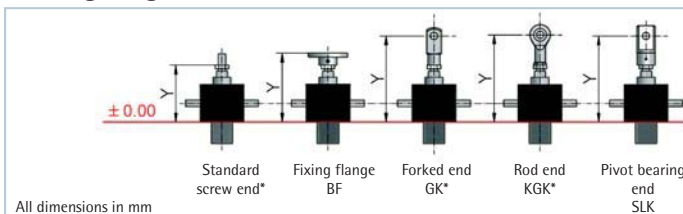

All dimensions in mm

Bellocs FB	Y	Y	Y	Y	Y
without bellocs FB	94	114	142	144	142
Z-5-FB-265	127	127	175	177	155
Z-5-FB-500	192	192	240	242	220
Z-5-FB-800	212	212	260	262	240

*with bellows fixing ring Z-5-FBR

6) Protective tube length SRO with Tr 18x4 screw

Without escape/ rotation protection	Escape/ rotation protection	Rotation protection, with limit switch set ES	Rotation protection with ES and KAR*
46+stroke	61+stroke	119+stroke	140+stroke

*Hinged bearing plate KAR, fitted on face F (below).

Standard ratios

Type	Version	Speed	Standard screw ²⁾	i	Stroke per drive shaft rotation ⁵⁾
GSZ-5-SN	Translating	Normal	Tr 18x4	4:1	1.00 mm
GSZ-5-SL	screw	Low speed		16:1	0.25 mm
GSZ-5-RN	Rotating	Normal	Tr 18x4	4:1	1.00 mm
GSZ-5-RL	screw	Low speed		16:1	0.25 mm

Screw jack mounting

max. load: 5 kN compressive and tensile load
Screw: M8, strength class 8.8
Screw-in depth: 10 to 11.5 mm
Tightening torque: 19 Nm
Screw locking: with Loctite 243

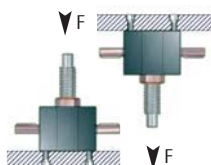

Duty cycle thermal limit, for S+R

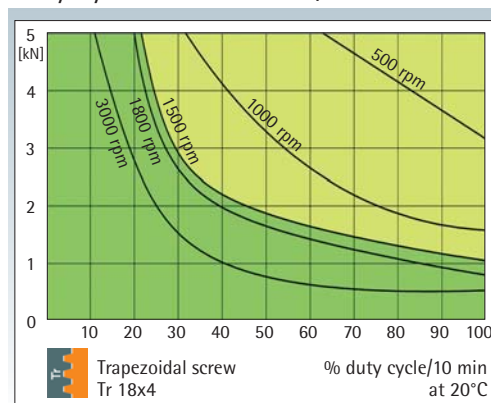

These curves are for guidance under standard industrial conditions (ambient temperature etc.) and correct maintenance (lubrication etc.). The max. input drive torques for optimum service life are at the right page - technical data (1500 rpm)

KGK:
% duty cycle
2 times to
4 times higher

Trapezoidal screw

Tr



GSZ-5-R rotating screw 5 kN

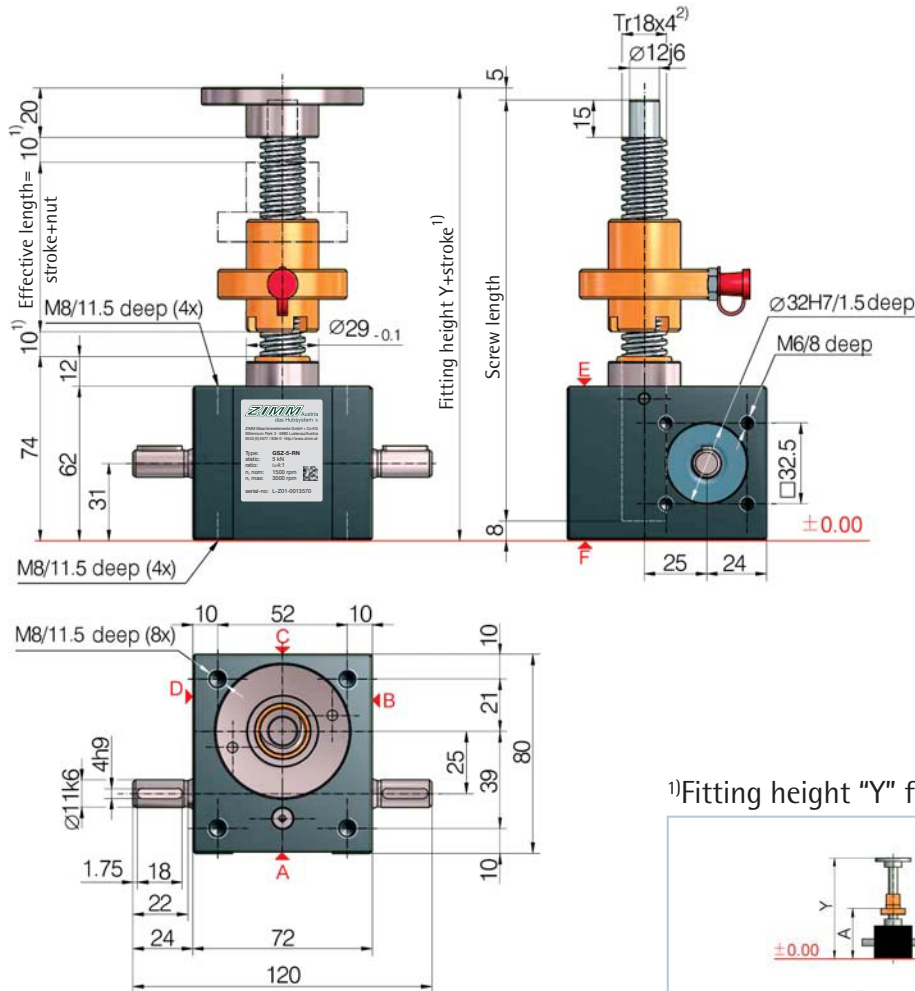
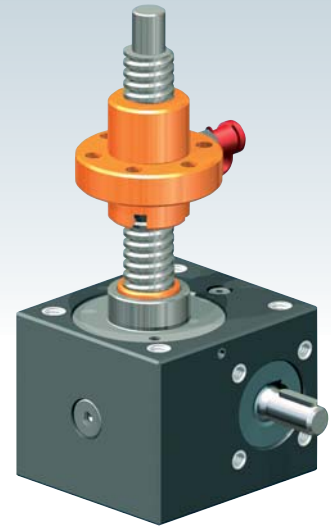

¹⁾Fitting height "Y" for 0-stroke, with Tr 18x4 screw

All dimensions in mm	Flange nut FM	Duplex nut DM	Duplex nut DM with SIFA	Self-aligning nut PM	Greasless nut FFDM
Bellows FB	Y/A	Y/A	Y/A	Y/A	Y/A
without bellows FB	149/96	159/109	184/134	192/141	167/117
2x Z-5-FB-265	-	207/132	229/154	240/164	215/140
2x Z-5-FB-500	-	337/197	359/219	370/229	345/205
2x Z-5-FB-800	-	377/217	399/239	410/249	385/225

Detailed instructions for determining the length can be found in Section 8

5 kN

Technical data series GSZ-5-S / GSZ-5-R

max. compressive/tensile force, static	- 5 kN (500 kg)
max. compressive/tensile force, dynamic	- see duty cycle curves
Nominal speed	- 1500 rpm
max. drive shaft speed	- 3000 rpm (depending on the load and duty cycle)
Screw size standard	- Tr 18x4 ²⁾
Gear ratio	- 4:1 (N) / 16:1 (L)
Housing material	- aluminium, corrosion-resistant
Worm shaft	- steel, case-hardened, ground
Weight of screw jack body	- 1.2 kg
Weight of screw/m	- 1.58 kg
Gearbox lubrication	- synthetic fluid grease
Screw lubrication	- grease lubrication
Gearbox operating temperature	- max. 60°C, higher on request
Moment of inertia	- N: 0.217 kg cm ² / L: 0.117 kg cm ²
Input torque (at 1500 rpm)	- max. 4.7 Nm (N) / max. 1.5 Nm (L)
Drive-through torque	- max. 39 Nm

Drive torque M_0 (Nm)	- F (kN) \times 0.62 ³⁾⁵⁾ + M_L (N-normal)
Breakaway torque	- F (kN) \times 0.21 ³⁾⁵⁾ + M_L (L-low speed)
Idling torque ⁴⁾ M_L (Nm)	- Drive torque M_0 \times 1.5
	- 0.10 (N-normal) / 0.08 (L-low speed)

Between gearbox and nut or nut and end of thread, provide for a safety distance of (minimum) 10 mm!

See Section 7 for the checklist.

Important information

- 1) - extension if a bellows or spiral spring is fitted: see the table or Section 8
- 2) - Tr 18x4 is standard, also available: double-pitch, stainless steel, left-handed, increased screw Tr 20x4 (only for the R version)
- 3) - factor includes efficiency, ratio and 30% safety
- 4) - at 20°C, can be higher when new
- 5) - for a 4 mm screw pitch



UNIQUE:
Screw lubrication
during operation

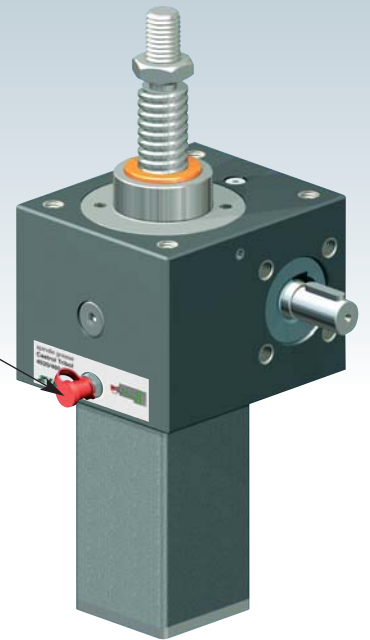

GSZ-10-S translating screw 10 kN

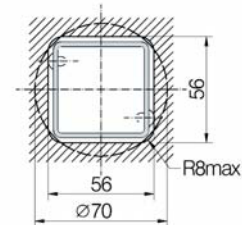
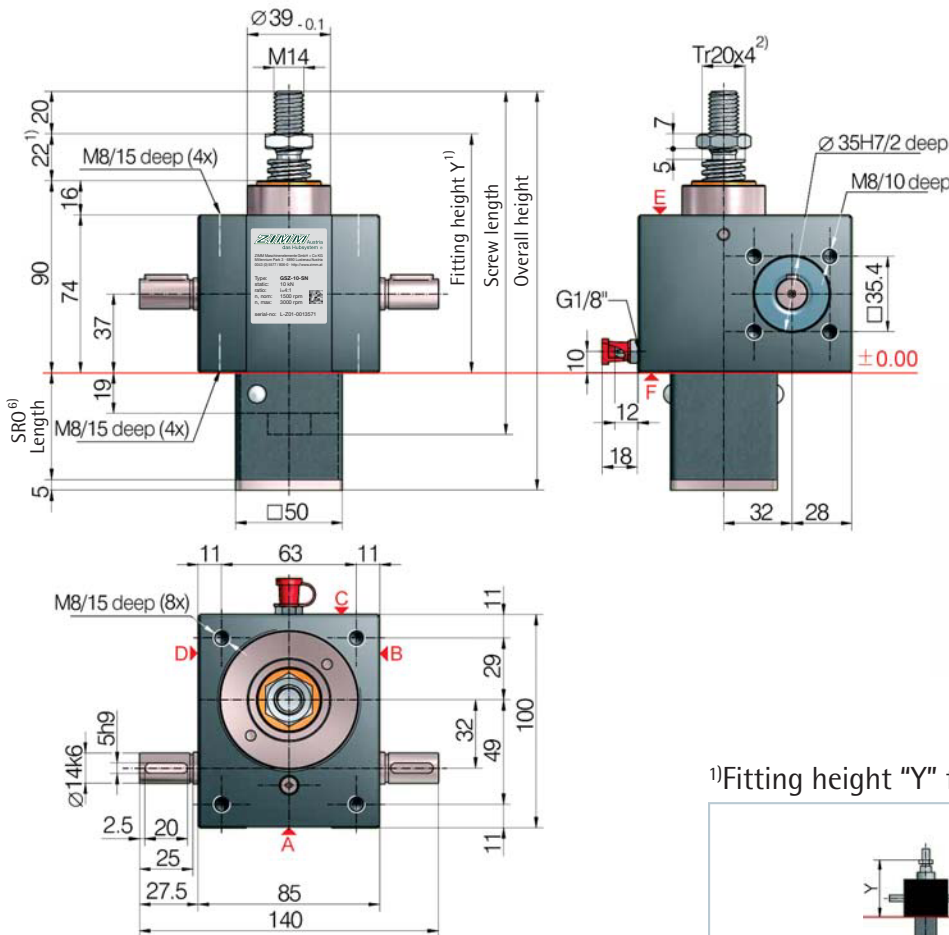

Opening for protective tube SRO, square 56x56 or round $\varnothing 70$

6) Protective tube length SRO with Tr 20x4 screw

Without escape/ rotation protection	Escape/ rotation protection	Rotation protection, with limit switch set ES	Rotation protection with ES and KAR*
49+stroke	69+stroke	121+stroke	141+stroke

*Hinged bearing plate KAR, fitted on face F (below).

1) Fitting height "Y" for 0-stroke, with Tr 20x4 screw

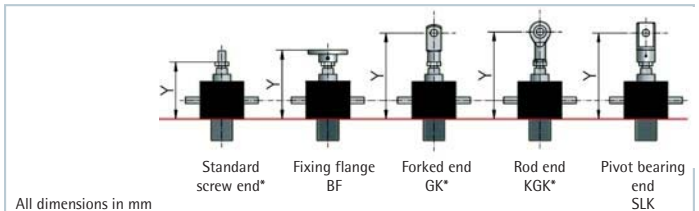

All dimensions in mm

Bellocs FB	Y	Y	Y	Y	Y
without bellocs FB	112	133	168	173	168
Z-10-FB-340	193	189	249	254	224
Z-10-FB-700	213	209	269	274	244
Z-10-FB-1000	263	259	319	324	294

*with bellocs fixing ring Z-10-FBR

Standard ratios

Type	Version	Speed	Standard screw ²⁾	i	Stroke per drive shaft rotation ⁵⁾
GSZ-10-SN	Translating	Normal	Tr 20x4	4:1	1.00 mm
GSZ-10-SL	screw	Low speed		16:1	0.25 mm
GSZ-10-RN	Rotating	Normal	Tr 20x4	4:1	1.00 mm
GSZ-10-RL	screw	Low speed		16:1	0.25 mm

Screw jack mounting

- max. load: 10 kN compressive and tensile load
- Screw: M8, strength class 8.8
- Screw-in depth: 10 to 15 mm
- Tightening torque: 17 Nm
- Screw locking: with Loctite 243

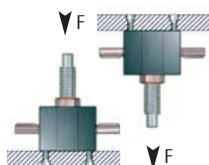

Duty cycle thermal limit, for S+R

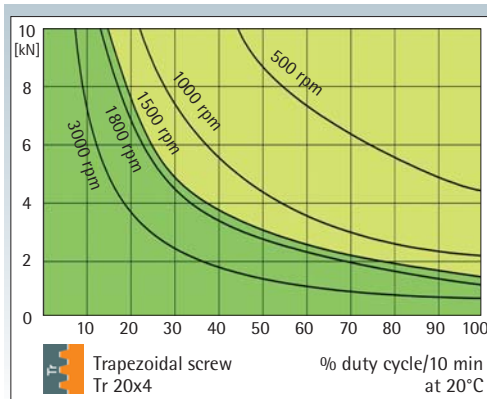

These curves are for guidance under standard industrial conditions (ambient temperature etc.) and correct maintenance (lubrication etc.). The max. input drive torques for optimum service life are at the right page - technical data (1500 rpm)

KGT:
% duty cycle
2 times to
4 times higher

Trapezoidal screw

Tr



GSZ-10-R rotating screw 10 kN

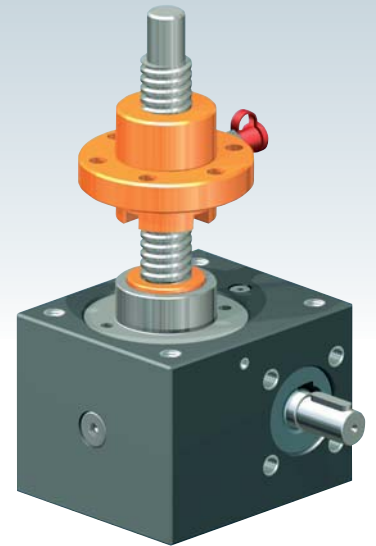
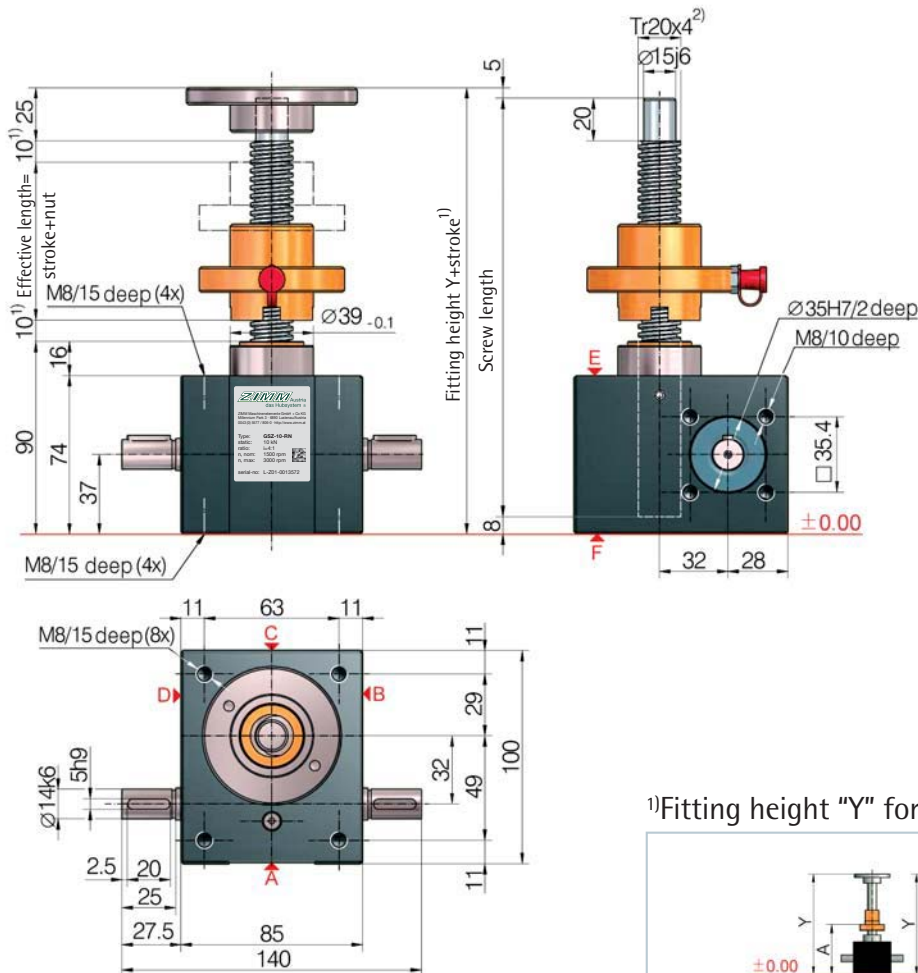

¹⁾Fitting height "Y" for 0-stroke, with Tr 20x4 screw

All dimensions in mm	Flange nut FM	Duplex nut DM	Duplex nut DM with SIFA	Self-aligning nut PM	Greasless nut FFDM
Bellows FB	Y/A	Y/A	Y/A	Y/A	Y/A
without bellows FB	179/112	180/125	219/164	218/159	188/133
2x Z-10-FB-340	-	314/193	350/229	352/227	322/201
2x Z-10-FB-700	-	354/213	390/249	392/247	362/221
2x Z-10-FB-1000	-	454/263	490/299	492/297	462/271

Detailed instructions for determining the length can be found in Section 8

10 kN

Technical data series GSZ-10-S / GSZ-10-R

max. compressive/tensile force, static	- 10 kN (1 t)
max. compressive/tensile force, dynamic	- see duty cycle curves
Nominal speed	- 1500 rpm
max. drive shaft speed	- 3000 rpm (depending on the load and duty cycle)
Screw size standard	- Tr 20x4 ²⁾
Gear ratio	- 4:1 (N) / 16:1 (L)
Housing material	- aluminium, corrosion-resistant
Worm shaft	- steel, case-hardened, ground
Weight of screw jack body	- 2.1 kg
Weight of screw/m	- 2 kg
Gearbox lubrication	- synthetic fluid grease
Screw lubrication	- grease lubrication
Gearbox operating temperature	- max. 60°C, higher on request
Moment of inertia	- N: 0.641 kg cm ² / L: 0.271 kg cm ²
Input torque (at 1500 rpm)	- max. 13.5 Nm (N) / max. 7.5 Nm (L)
Drive-through torque	- max. 57 Nm

Drive torque M_G (Nm)	- F (kN) \times 0.64 ³⁾⁵⁾ + M_L (N-normal)
Breakaway torque	- F (kN) \times 0.20 ³⁾⁵⁾ + M_L (L-low speed)
Idling torque ⁴⁾ M_L (Nm)	- Drive torque M_G \times 1.5
	- 0.26 (N-normal) / 0.16 (L-low speed)

Between gearbox and nut or nut and end of thread, provide for a safety distance of (minimum) 10 mm!

See Section 7 for the checklist.

Important information

- 1) - extension if a bellows or spiral spring is fitted: see the table or Section 8
- 2) - Tr 20x4 is standard, also available: double-pitch, stainless steel, left-handed, increased screw Tr 30x6 (only for the R version)
- 3) - factor includes efficiency, ratio and 30% safety
- 4) - at 20°C, can be higher when new
- 5) - for a 4 mm screw pitch



UNIQUE:
Screw lubrication
during operation

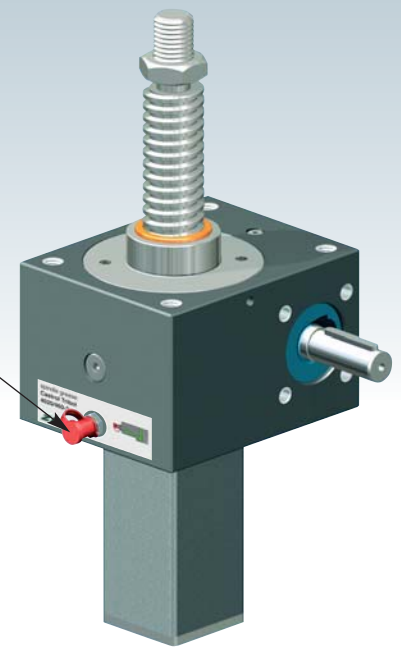

GSZ-25-S translating screw 25 kN

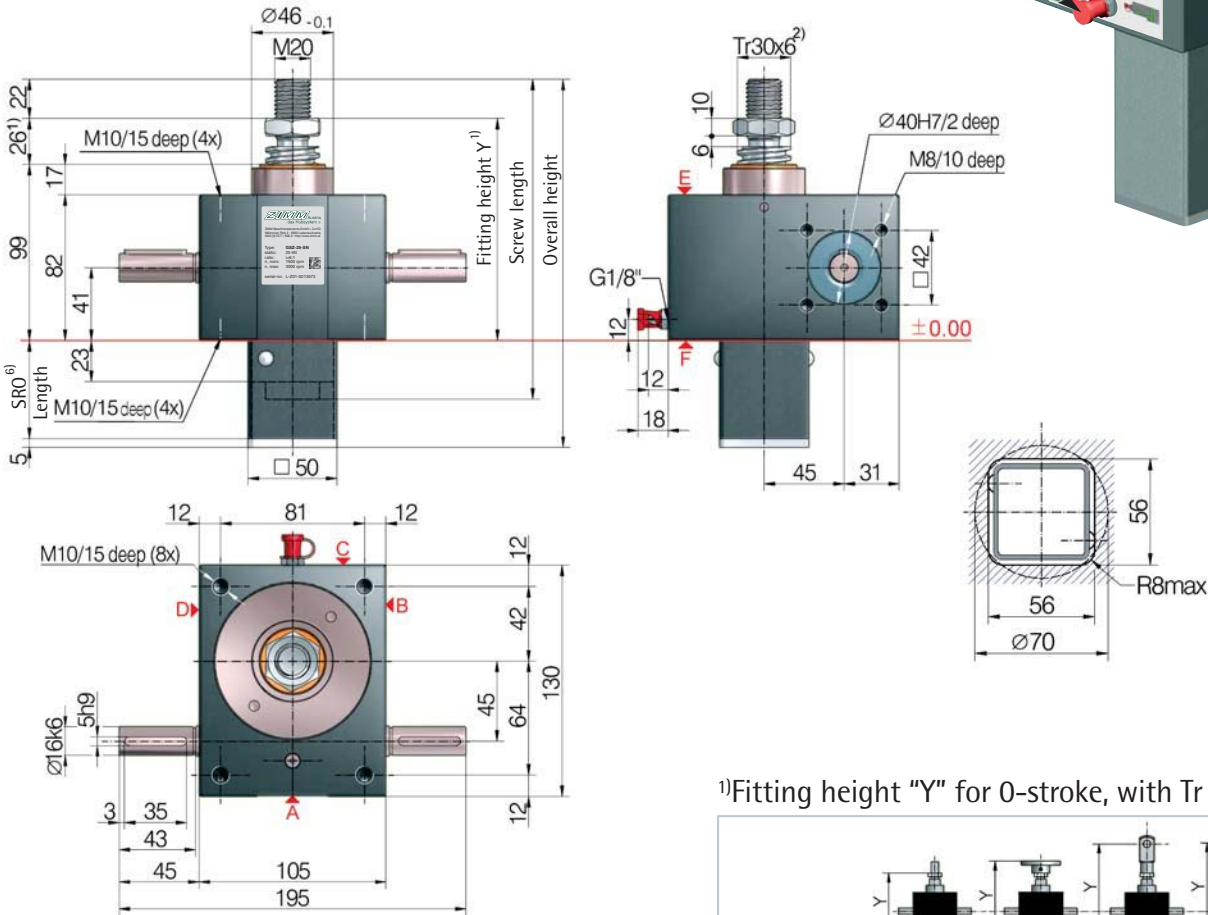

1) Fitting height "Y" for 0-stroke, with Tr 30x6 screw

Bellocs FB	Y	Y	Y	Y	Y
without bellocs FB	125	148	205	202	205
Z-25-FB-300	200	192	280	277	249
Z-25-FB-700	230	222	310	307	279
Z-25-FB-1000	250	242	330	327	299

6) Protective tube length SRO with Tr 30x6 screw

Without escape/ rotation protection	Escape/ rotation protection	Rotation protection, with limit switch set ES	Rotation protection with ES and KAR*
53+stroke	73+stroke	125+stroke	149+stroke

*Hinged bearing plate KAR, fitted on face F (below).

Standard ratios

Type	Version	Speed	Standard screw ²⁾	i	Stroke per drive shaft rotation ⁵⁾
GSZ-25-SN	Translating	Normal	Tr 30x6	6:1	1.00 mm
GSZ-25-SL	screw	Low speed		24:1	0.25 mm
GSZ-25-RN	Rotating	Normal	Tr 30x6	6:1	1.00 mm
GSZ-25-RL	screw	Low speed		24:1	0.25 mm

Screw jack mounting

- max. load: 25 kN compressive and tensile load
- Screw: M10, strength class 8.8
- Screw-in depth: 12 to 15 mm
- Tightening torque: 27 Nm
- Screw locking: with Loctite 243

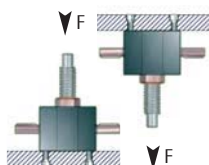

Duty cycle thermal limit, for S+R

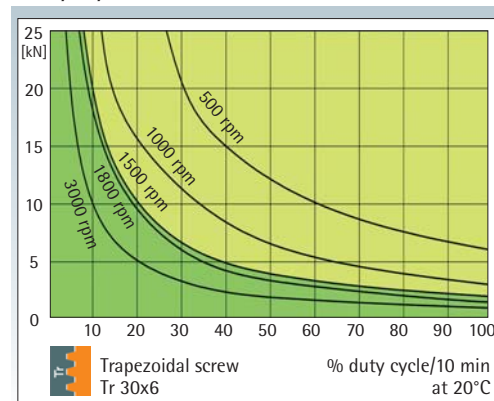

These curves are for guidance under standard industrial conditions (ambient temperature etc.) and correct maintenance (lubrication etc.). The max. input drive torques for optimum service life are at the right page - technical data (1500 rpm)

KGT:
% duty cycle
2 times to
4 times higher

Trapezoidal screw

Tr



GSZ-25-R rotating screw 25 kN

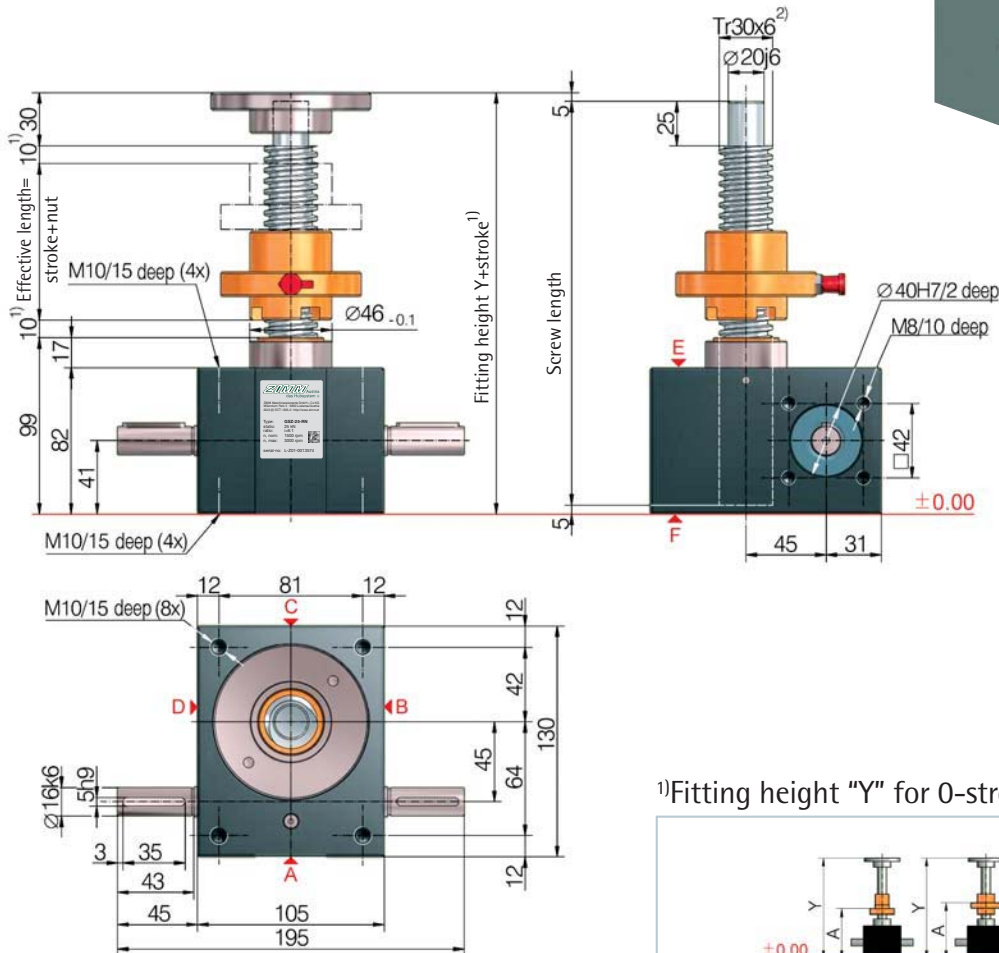
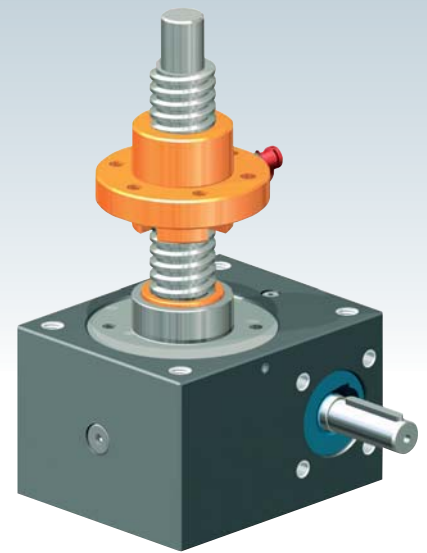

¹⁾Fitting height "Y" for 0-stroke, with Tr 30x6 screw

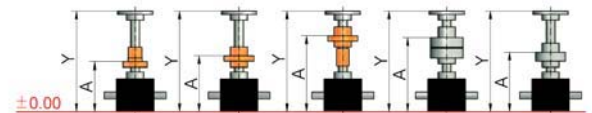

All dimensions in mm	Flange nut FM	Duplex nut DM	Duplex nut DM with SIFA	Self-aligning nut PM	Greasless nut FFDM
Bellows FB	Y/A	Y/A	Y/A	Y/A	Y/A
without bellows FB	195/123	199/136	244/181	244/177	208/145
2x Z-25-FB-300	-	314/196	353/235	359/237	325/207
2x Z-25-FB-700	-	374/226	413/265	419/267	385/237
2x Z-25-FB-1000	-	414/246	453/285	459/287	425/257

Detailed instructions for determining the length can be found in Section 8

25 kN

Technical data series GSZ-25-S / GSZ-25-R

max. compressive/tensile force, static	- 25 kN (2.5 t)
max. compressive/tensile force, dynamic	- see duty cycle curves
Nominal speed	- 1500 rpm
max. drive shaft speed	- 3000 rpm (depending on the load and duty cycle)
Screw size standard	- Tr 30x6 ²⁾
Gear ratio	- 6:1 (N) / 24:1 (L)
Housing material	- aluminium, corrosion-resistant
Worm shaft	- steel, case-hardened, ground
Weight of screw jack body	- 3.8 kg
Weight of screw/m	- 4.5 kg
Gearbox lubrication	- synthetic fluid grease
Screw lubrication	- grease lubrication
Gearbox operating temperature	- max. 60°C, higher on request
Moment of inertia	- N: 1.449 kg cm ² / L: 0.589 kg cm ²
Input torque (at 1500 rpm)	- max. 18 Nm (N) / max. 10 Nm (L)
Drive-through torque	- max. 108 Nm

Drive torque M_6 (Nm)	- F (kN) x 0.63 ³⁾⁵⁾ (N-normal)
	- F (kN) x 0.20 ³⁾⁵⁾ (L-low speed)
Breakaway torque	- Drive torque M_6 x 1.5
Idling torque ⁴⁾ M_L (Nm)	- 0.36 (N-normal) / 0.26 (L-low speed)

Between gearbox and nut or nut and end of thread, provide for a safety distance of (minimum) 10 mm!

See Section 7 for the checklist.

Important information

- 1) - extension if a bellows or spiral spring is fitted: see the table or Section 8
- 2) - Tr 30x6 is standard, also available: double-pitch, stainless steel, left-handed, increased screw Tr 40x7 (only for the R version)
- 3) - factor includes efficiency, ratio and 30% safety
- 4) - at 20°C, can be higher when new
- 5) - for a 6 mm screw pitch

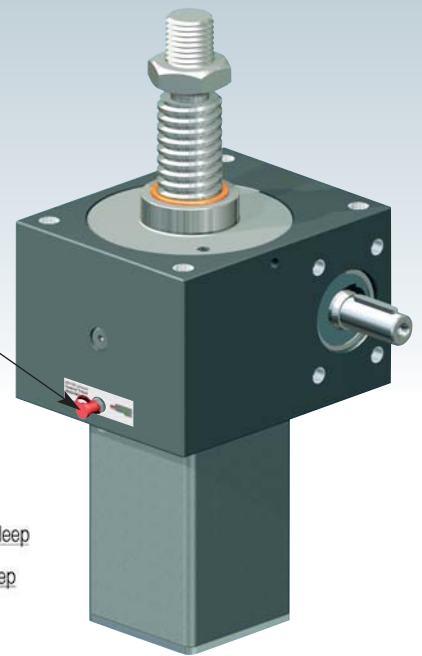

UNIQUE:
Screw lubrication
during operation

GSZ-50-S translating screw 50 kN

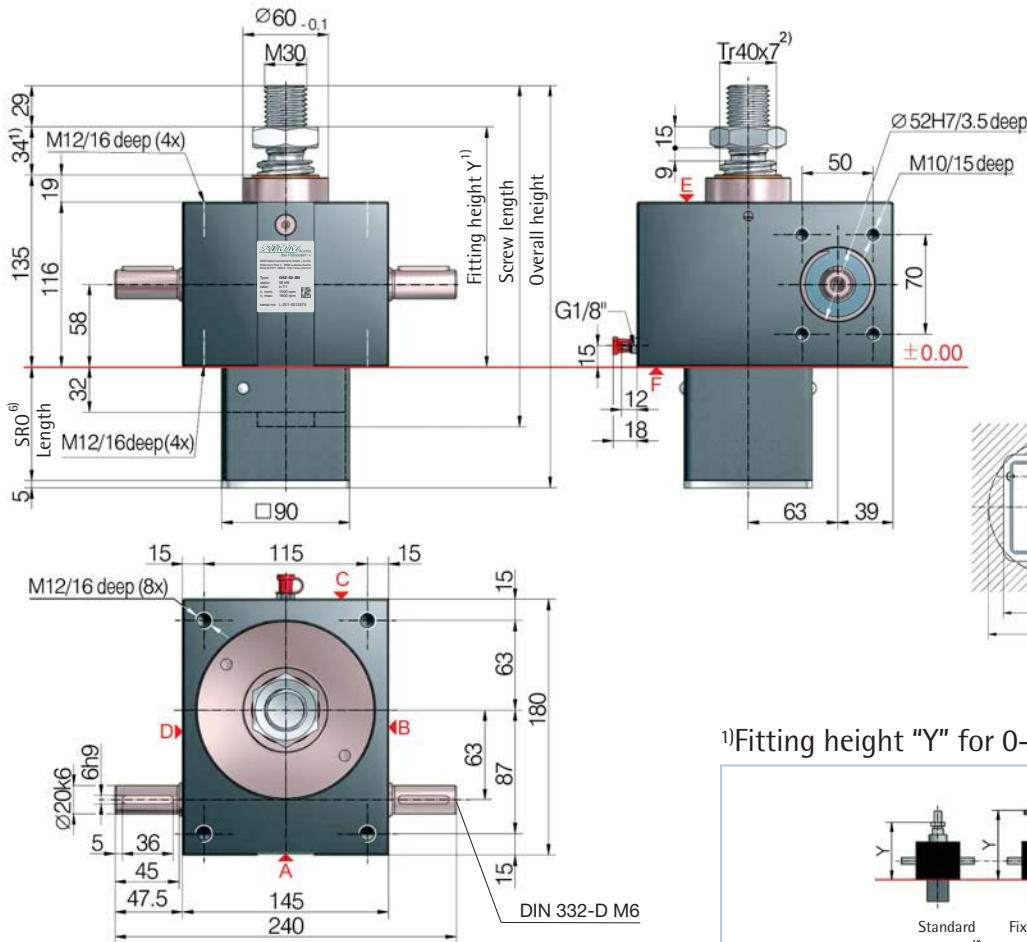

1) Fitting height "Y" for 0-stroke, with Tr 40x7 screw

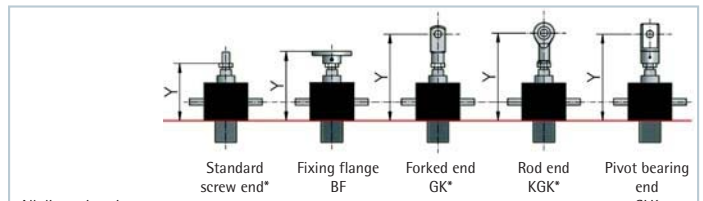

All dimensions in mm

Bellocs FB	Y	Y	Y	Y	Y
without bellocs FB	169	199	289	279	261
Z-50-FB-390	264	248	384	374	310
Z-50-FB-600	251	235	371	361	297
Z-50-FB-1000	309	293	429	419	355
Z-50-FB-1200	304	288	424	414	350
Z-50-FB-1500	359	343	479	469	405

*with bellows fixing ring Z-50-FBR

6) Protective tube length SRO with Tr 40x7 screw

Without escape/ rotation protection	Escape/ rotation protection	Rotation protection, with limit switch set ES	Rotation protection with ES and KAR*
62+stroke	92+stroke	144+stroke	169+stroke

*Hinged bearing plate KAR, fitted on face F (below).

Standard ratios

Type	Version	Speed	Standard screw ²⁾	i	Stroke per drive shaft rotation ⁵⁾
GSZ-50-SN	Translating	Normal	Tr 40x7	7:1	1.00 mm
GSZ-50-SL	screw	Low speed		28:1	0.25 mm
GSZ-50-RN	Rotating	Normal	Tr 40x7	7:1	1.00 mm
GSZ-50-RL	screw	Low speed		28:1	0.25 mm

Screw jack mounting

- max. load: 50 kN compressive and tensile load
- Screw: M12, strength class 8.8
- Screw-in depth: 12 to 17 mm
- Tightening torque: 38 Nm
- Screw locking: with Loctite 243

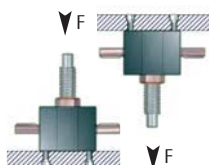

Duty cycle thermal limit, for S+R

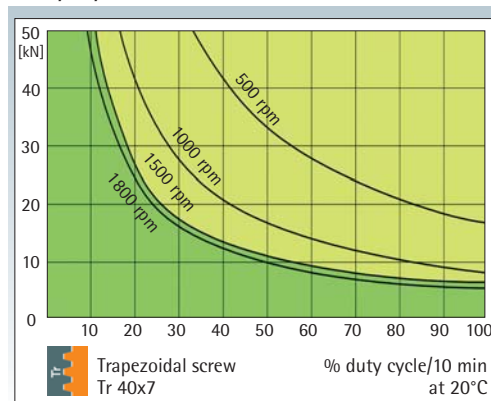

These curves are for guidance under standard industrial conditions (ambient temperature etc.) and correct maintenance (lubrication etc.). The max. input drive torques for optimum service life are at the right page - technical data (1500 rpm)

KGK: % duty cycle 2 times to 4 times higher

Trapezoidal screw

Tr



GSZ-50-R rotating screw 50 kN

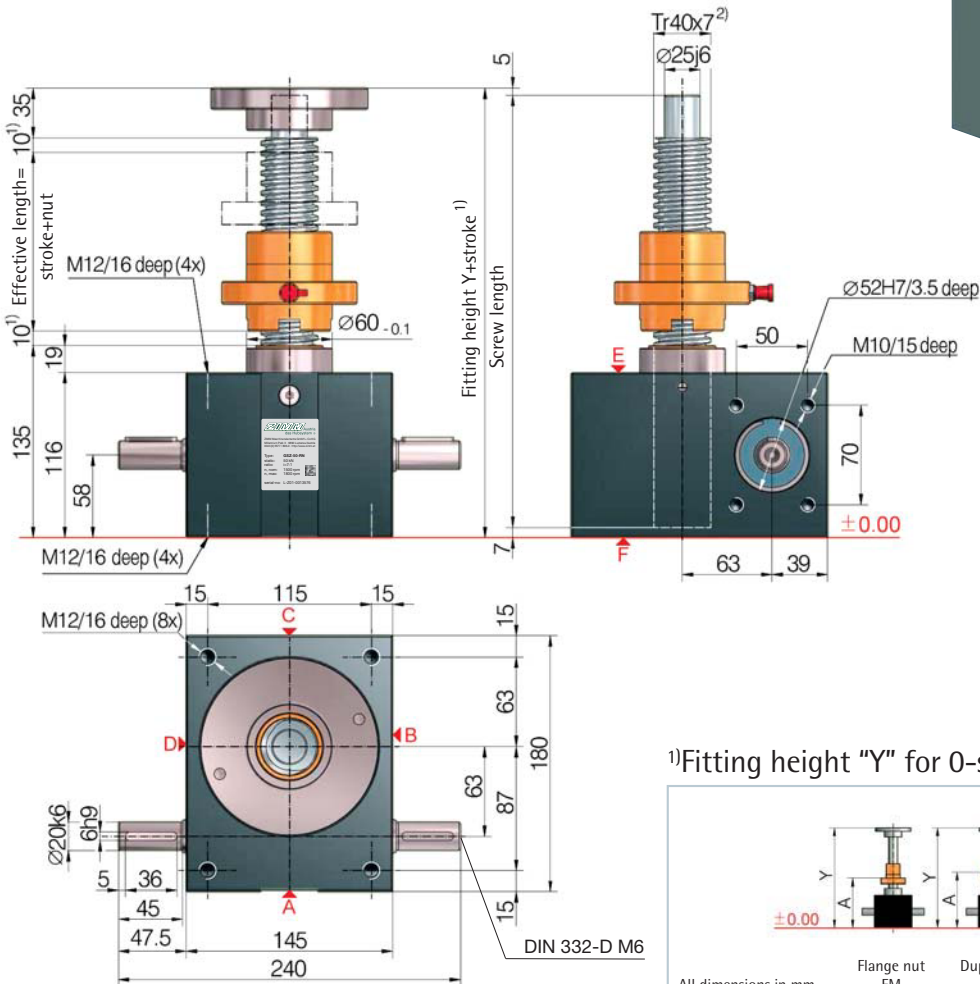
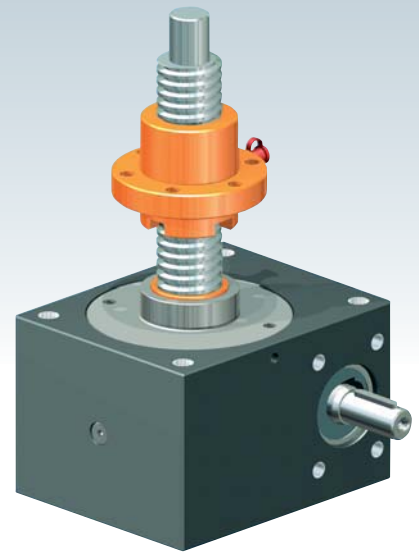

¹⁾Fitting height "Y" for 0-stroke, with Tr 40x7 screw

All dimensions in mm	Flange nut FM	Duplex nut DM	Duplex nut DM with SIFA	Self-aligning nut PM	Greasless nut FFDM
Bellocs FB	Y/A	Y/A	Y/A	Y/A	Y/A
without bellocs FB	256/161	260/179	323/242	319/244	275/195
2x Z-50-FB-390	-	403/252	462/311	462/317	420/270
2x Z-50-FB-600	-	377/239	436/298	436/304	394/257
2x Z-50-FB-1000	-	493/297	552/356	552/362	510/315
2x Z-50-FB-1200	-	483/292	542/351	542/357	500/310
2x Z-50-FB-1500	-	593/347	652/406	652/412	610/365

Detailed instructions for determining the length can be found in Section 8

50

kN

Technical data series GSZ-50-S / GSZ-50-R

max. compressive/tensile force, static	- 50 kN (5 t)
max. compressive/tensile force, dynamic	- see duty cycle curves
Nominal speed	- 1500 rpm
max. drive shaft speed	- 1800 rpm (depending on the load and duty cycle)
Screw size standard	- Tr 40x7 ²⁾
Gear ratio	- 7:1 (N) / 28:1 (L)
Housing material	- GGG-50, corrosion-resistant
Worm shaft	- steel, case-hardened, ground
Weight of screw jack body	- 15 kg
Weight of screw/m	- 8 kg
Gearbox lubrication	- synthetic fluid grease
Screw lubrication	- grease lubrication
Gearbox operating temperature	- max. 60°C, higher on request
Moment of inertia	- N: 6.40 kg cm ² / L: 2.53 kg cm ²
Input torque (at 1500 rpm)	- max. 31.5 Nm (N) / max. 10.4 Nm (L)
Drive-through torque	- max. 260 Nm

Drive torque M_G (Nm)	- F (kN) \times 0.68 ³⁾⁵⁾ + M_L (N-normal)
	- F (kN) \times 0.23 ³⁾⁵⁾ + M_L (L-low speed)
Breakaway torque	- Drive torque $M_G \times 1.5$
Idling torque ⁴⁾ M_L (Nm)	- 0.76 (N-normal) / 0.54 (L-low speed)

Between gearbox and nut or nut and end of thread, provide for a safety distance of (minimum) 10 mm!

See Section 7 for the checklist.

Important information

- 1) - extension if a bellows or spiral spring is fitted: see the table or Section 8
- 2) - Tr 40x7 is standard, also available: double-pitch, stainless steel, left-handed, increased screw Tr 55x9 (only for the R version)
- 3) - factor includes efficiency, ratio and 30% safety
- 4) - at 20°C, can be higher when new
- 5) - for a 7 mm screw pitch

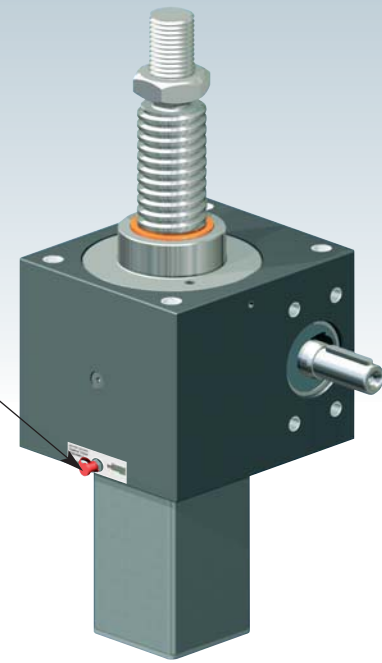

UNIQUE:
Screw lubrication
during operation

GSZ-100-S translating screw 100 kN

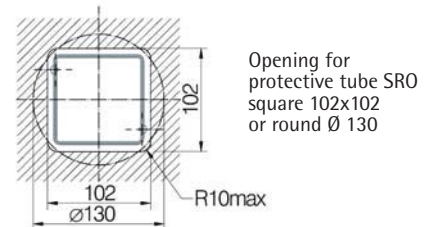
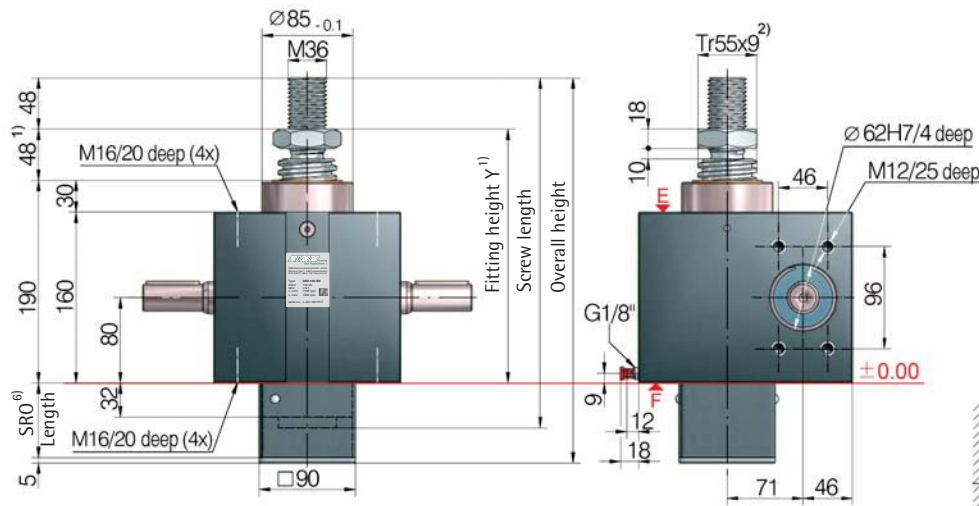

¹⁾Fitting height "Y" for 0-stroke, with Tr 55x9 screw

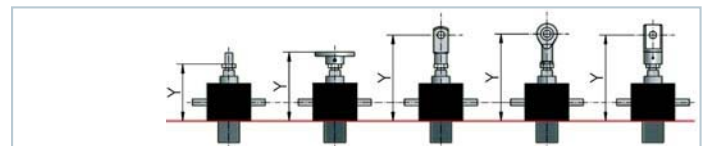

All dimensions in mm

Bellocs FB	Y	Y	Y	Y	Y
without bellocs FB	238	288	382	380	346
Z-100-FB-285	311	313	455	453	371
Z-100-FB-600	308	310	452	450	368
Z-100-FB-1000	366	368	510	508	426
Z-100-FB-1500	416	418	560	558	476

⁶⁾Protective tube length SRO with Tr 55x9 screw

Without escape/ rotation protection	Escape/ rotation protection	Rotation protection, with limit switch set ES	Rotation protection with ES and KAR*
82+stroke	112+stroke	144+stroke	189+stroke

*Hinged bearing plate KAR, fitted on face F (below)

*with bellocs fixing ring Z-100-FBR

Standard ratios

Type	Version	Speed	Standard screw ²⁾	i	Stroke per drive shaft rotation ⁵⁾
GSZ-100-SN	Translating	Normal	Tr 55x9	9:1	1.00 mm
GSZ-100-SL	screw	Low speed		36:1	0.25 mm
GSZ-100-RN	Rotating	Normal	Tr 55x9	9:1	1.00 mm
GSZ-100-RL	screw	Low speed		36:1	0.25 mm

Screw jack mounting

- max. load: 100 kN compressive and tensile load
- Screw: M16, strength class 8.8
- Screw-in depth: 16 to 22 mm
- Tightening torque: 82 Nm
- Screw locking: with Loctite 243

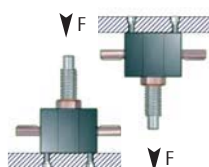

Duty cycle thermal limit, for S+R

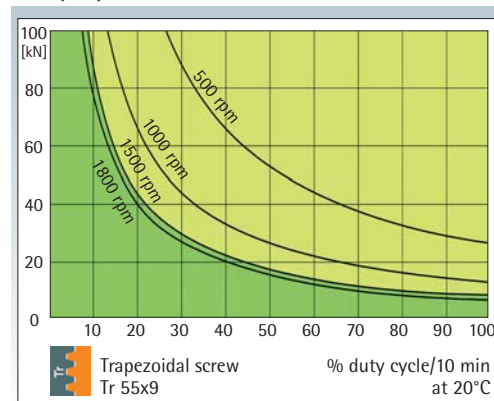

These curves are for guidance under standard industrial conditions (ambient temperature etc.) and correct maintenance (lubrication etc.). The max. input drive torques for optimum service life are at the right page - technical data (1500 rpm)

KGK: % duty cycle 2 times to 4 times higher

Trapezoidal screw

Tr



GSZ-100-R rotating screw 100 kN

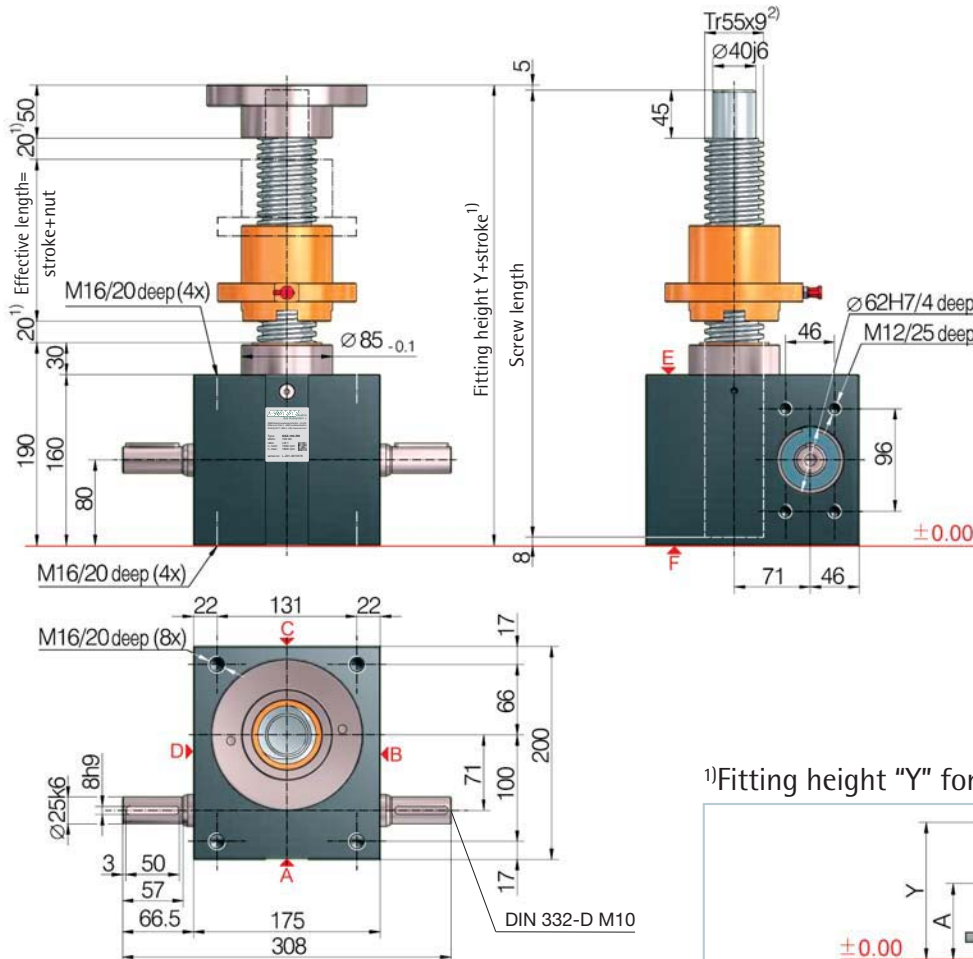
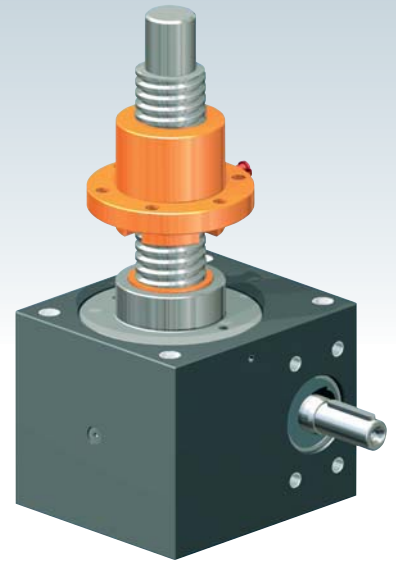

¹⁾Fitting height "Y" for 0-stroke, with Tr 55x9 screw

All dimensions in mm	Duplex nut DM	Duplex nut DM with SIFA	Self-aligning nut PM
Bellocs FB	Y/A	Y/A	Y/A
without bellows FB	370/246	453/329	470/355
2x Z-100-FB-285	478/299	556/377	578/408
2x Z-100-FB-600	472/296	550/374	572/405
2x Z-100-FB-1000	588/354	666/432	688/463
2x Z-100-FB-1500	688/404	766/482	788/513

Detailed instructions for determining the length can be found in Section 8

100 kN

Technical data series GSZ-100-S / GSZ-100-R

max. compressive/tensile force, static	- 100 kN (10 t)
max. compressive/tensile force, dynamic	- see duty cycle curves
Nominal speed	- 1500 rpm
max. drive shaft speed	- 1800 rpm (depending on the load and duty cycle)
Screw size standard	- Tr 55x9 ²⁾
Gear ratio	- 9:1 (N) / 36:1 (L)
Housing material	- GGG-50, corrosion-resistant
Worm shaft	- steel, case-hardened, ground
Weight of screw jack body	- 33 kg
Weight of screw/m	- 15.7 kg
Gearbox lubrication	- synthetic fluid grease
Screw lubrication	- grease lubrication
Gearbox operating temperature	- max. 60°C, higher on request
Moment of inertia	- N: 12.53 kg cm ² / L: 4.75 kg cm ²
Input torque (at 1500 rpm)	- max. 53.4 Nm (N) / max. 13.5 Nm (L)
Drive-through torque	- max. 540 Nm

Drive torque M_0 (Nm)	- F (kN) \times 0.72 ³⁾⁵⁾ + M_L (N-normal)
Breakaway torque	- F (kN) \times 0.23 ³⁾⁵⁾ + M_L (L-low speed)
Idling torque ⁴⁾ M_L (Nm)	- Drive torque M_0 \times 1.5
	- 1.68 (N-normal) / 1.02 (L-low speed)

Between gearbox and nut or nut and end of thread, provide for a safety distance of (minimum) 20 mm!

See Section 7 for the checklist.

Important information

- 1) - extension if a bellows or spiral spring is fitted: see the table or Section 8
- 2) - Tr 55x9 is standard, also available: double-pitch, stainless steel, left-handed, increased screw Tr 60x9 (only for the R version)
- 3) - factor includes efficiency, ratio and 30% safety
- 4) - at 20°C, can be higher when new
- 5) - for a 9 mm screw pitch

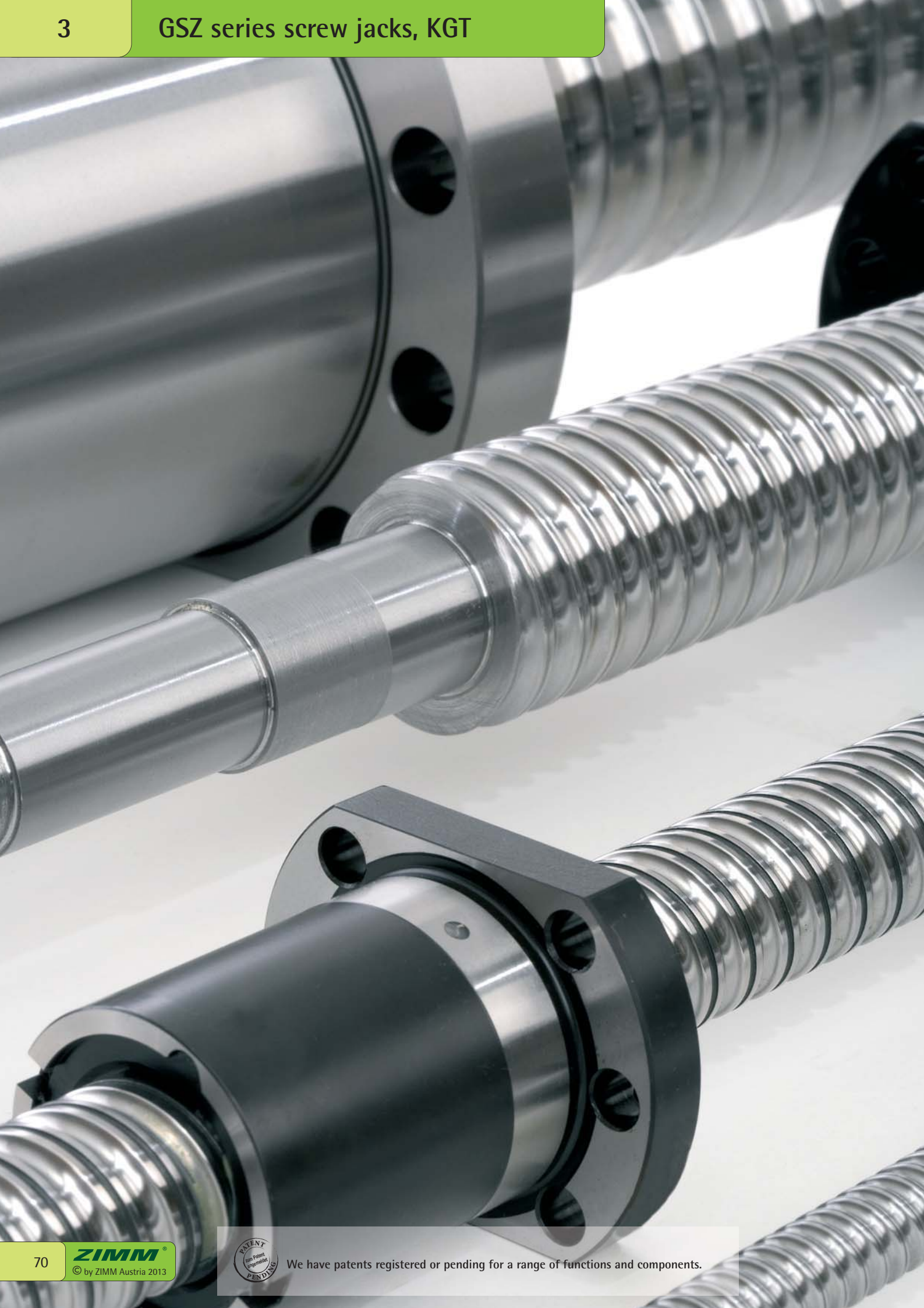

Ball screw KGT



Most screw jacks use trapezoidal screws Tr, because they are simple, robust and inexpensive. The proportion of screw jacks that use ball screws is however constantly increasing. The reasons for this are primarily their pitch accuracy, their high efficiency (less power consumption and less heat generation) and the higher pitches available, which permit higher stroke speeds.

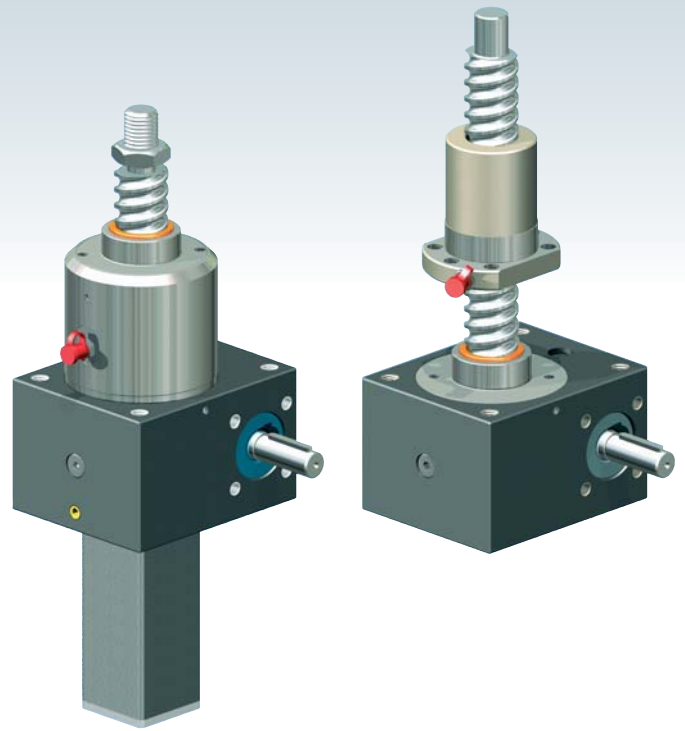

Technical data KGT

Pitch accuracy

0.05 mm / 300 mm

Material: 1.1213 (Cf 53), induction hardened and polished.

No self-locking!

Because of the lack of friction, a holding brake is necessary: a motor brake or a spring pressure brake is required.

Temperatures, duty cycle

Operating temperature range -25°C to + 80°C. The duty cycle can be up to 4 times higher than for trapezoidal screws (see diagrams), and at long strokes up to 2 times higher than for trapezoidal screws.

Service life

Heavy loads reduce the service life of the KGT. Tell us the load and stroke speed and we will calculate the service life.

Contamination

All nuts are fitted with scrapers. For heavy contamination and fine dust/chips, we recommend fitting bellows or a spiral spring cover.

Escape/rotation protection

Under no circumstances may the nut be screwed off the screw. We therefore always provide escape/rotation protection on the S version.

Start ramp / braking ramp

We recommend using a frequency converter or a soft start device, especially for high lead screw jacks. This allows regulation of the start ramp / braking ramp. This ensures protection for the entire system.

Safety clearance L3 can also be reduced at your own discretion, in particular for high pitches.

Grease nipples

The standard position of the grease nipple on the S version is on the gearbox face "C". Optionally, face A is available. Faces B and D are available on request.



We have patents registered or pending for a range of functions and components.



UNIQUE:
Ball screw lubrication
for the S version

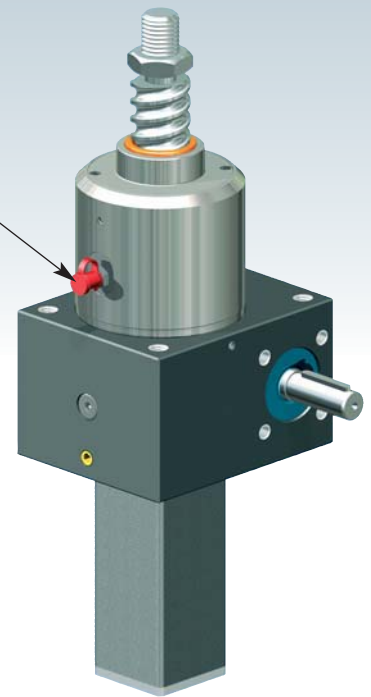

GSZ-5 to GSZ-100, KGT-S translating screw

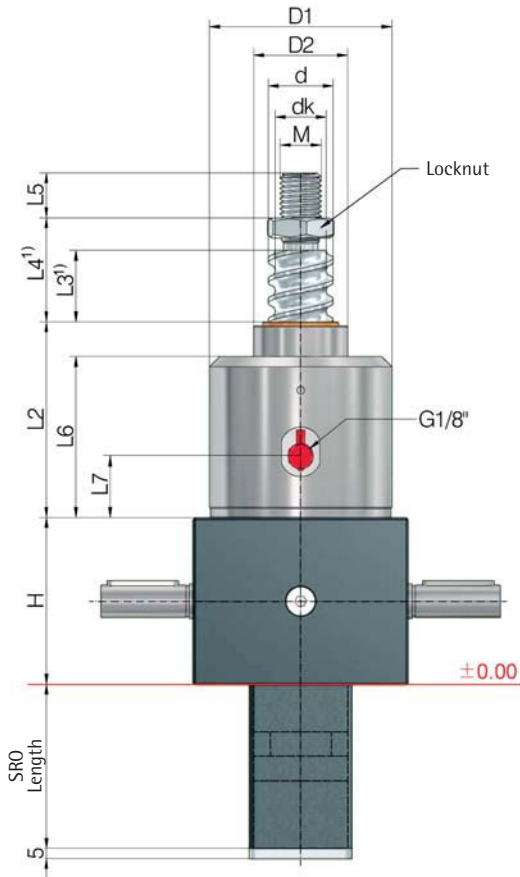

i - further technical information: Page 71
 - see the respective screw jack page for all other dimensions
 - see Section 4 for accessories
 - dimensions on the illustrative diagrams are in mm.
 We reserve the right to make changes.

🛒 **Ordering example:**
GSZ-100-SN-KGT 50x20, C = 112.4 kN
 dynamic load rating C

Screw jacks	Ball screw KGT	Stroke per drive revolution [mm]		KGT load rating [kN]		Dimensions [mm]											Axial play max ⁵⁾ [mm]	
		SN	SL	dyn. C ²⁾	stat. C ₀ =C _{0a}	H	d	dk	D ₁	D ₂	L ₂	L ₃ ¹⁾	L ₄ ¹⁾	L ₅	L ₆	L ₇		M
GSZ-5	16x5	1.25	0.31	9.3	13.1	62	15.5	12.9	59	29	66	15	25	19	54	23	M12	0.08
	16x10	2.50	0.63	15.4	26.5	62	15.4	13.0	59	29	66	25	35	19	54	23	M12	0.08
GSZ-10	25x5	1.25	0.31	12.3	22.5	74	24.5	21.9	69	39	85	15	27	20	69	21	M14	0.08
	25x10	2.50	0.63	13.2	25.3	74	24.5	21.9	69	39	85	25	37	20	69	21	M14	0.08
	25x25	6.25	1.56	16.7	32.2	74	24.5	22.0	69	39	85	60	72	20	69	21	M14	0.08
	25x50	12.50	3.13	15.4	31.7	74	24.1	21.5	69	39	85	125	137	20	69	21	M14	0.15
GSZ-25	32x5	0.83	0.21	21.5	49.3	82	31.5	28.9	89	46	99	15	31	22	82	33	M20	0.08
	32x10	1.67	0.42	33.4	54.5	82	32.7	27.3	89	46	99	20	36	22	82	33	M20	0.08
	32x20	3.33	0.83	29.7	59.8	82	31.7	27.9	89	46	99	35	51	22	82	33	M20	0.08
	32x40	6.67	1.67	14.9	32.4	82	30.9	28.3	89	46	99	70	86	22	82	33	M20	0.08
GSZ-50	40x5	0.71	0.18	23.8	63.1	116	39.5	36.9	125	60	93	15	39	29	74	17	M30	0.08
	40x10	1.43	0.36	38	69.1	116	39.5	34.1	125	60	93	15	39	29	74	17	M30	0.08
	40x20	2.86	0.72	33.3	76.1	116	39.7	35.9	125	60	93	30	54	29	74	17	M30	0.08
	40x40	5.71	1.43	35	101.9	116	38.9	36.3	125	60	93	60	84	29	74	17	M30	0.08
GSZ-100	50x10	1.11	0.28	68.7	155.8	160	49.5	44.1	148	85	112	20	48	48	82	19	M36	0.08
	50x20	2.22	0.56	60	136.3	160	49.5	44.1	148	85	112	40	68	48	82	19	M36	0.08
	50x10	1.11	0.28	112.1	338.5	160	50	43.6	148	85	148	20	48	48	118	19	M36	0.03
	50x20	2.22	0.56	112.4	214.7	160	50	41.1	148	85	148	40	68	48	118	19	M36	0.03
	50x40	4.44	1.11	84.7	143.1	160	50	41.1	148	85	148	80	108	48	118	19	M36	0.03

¹⁾ Depending on the control system and drive, the dimensions L₃ and L₄ can be reduced at your own discretion.
 An extension may be required if a bellows or spiral spring is fitted

²⁾ Dynamic load rating to DIN 69051 part 4 draft 1989.

⁵⁾ Reduced play 0.02 mm available on request.

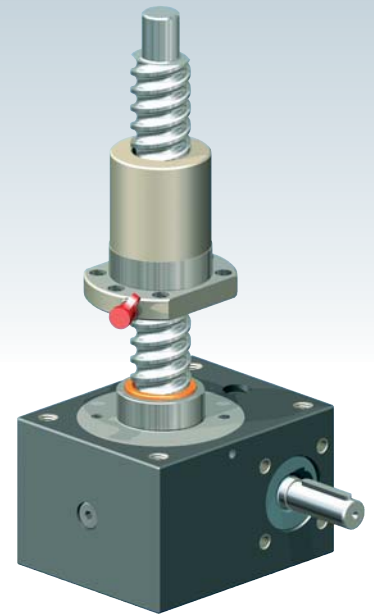

GSZ-2 to GSZ-100, KGT-R rotating screw

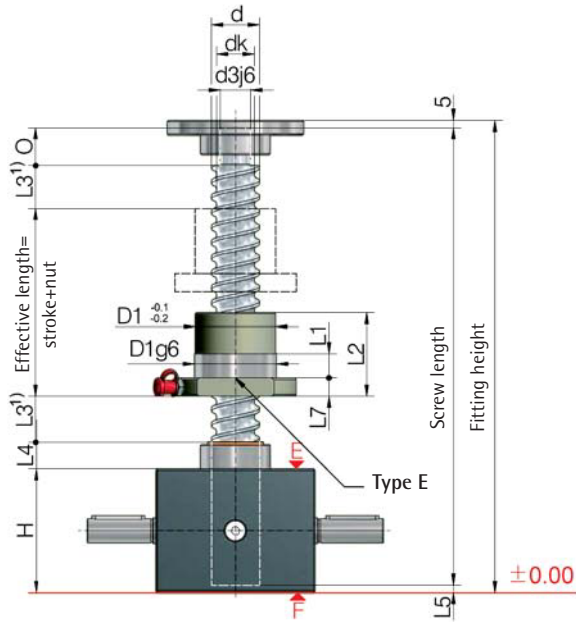

Position of the flange nut:
G = flange gearbox side
(as shown)
S = flange screw side

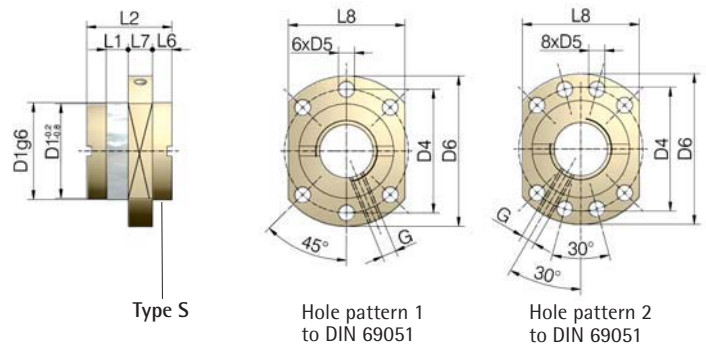

Adapter for KGT
Dimension sheet on request

An increased screw (such as: Z-10-RN with screw 32x10) can also be used for the rotating version.

Ordering example:
GSZ-100-RN-KGT 50x20, C = 112.4 kN - G
dynamic load rating C
Nut flange
G: flange gearbox side
S: flange screw side

Screw jacks	Ball screw KGT	Stroke per drive revolution [mm]		KGT load rating [kN]		Nut Type	Hole pattern	Dimensions [mm]																	Lubri-cation hole	Axial play max ⁵⁾ [mm]
		RN	RL	dyn. C ²⁾	stat. C ₀ =C _{0a}			d	dk	d ₃	O	H	D ₁	D ₄	D ₅	D ₆	L ₁	L ₂	L ₃ ¹⁾	L ₄	L ₅	L ₆	L ₇	L ₈		
GSZ-2	16x5	1.25	0.31	9.3	13.1	E 1	1	15.5	12.9	10	12	50	28	38	5.5	48	10	42	15	11	3	-	10	40	M6	0.08
	16x10	2.50	0.63	15.4	26.5	E 1	1	15.4	13.0	10	12	50	28	38	5.5	48	10	55	25	11	3	-	10	40	M6	0.08
GSZ-5	16x5	1.25	0.31	9.3	13.1	E 1	1	15.5	12.9	12	15	62	28	38	5.5	48	10	42	15	12	8	-	10	40	M6	0.08
	16x10	2.50	0.63	15.4	26.5	E 1	1	15.4	13.0	12	15	62	28	38	5.5	48	10	55	25	12	8	-	10	40	M6	0.08
GSZ-10	25x5	1.25	0.31	12.3	22.5	E 1	1	24.5	21.9	15	20	74	40	51	6.6	62	10	42	15	16	8	-	10	48	M6	0.08
	25x10	2.50	0.63	13.2	25.3	E 1	1	24.5	21.9	15	20	74	40	51	6.6	62	16	55	25	16	8	-	10	48	M6	0.08
	25x25 ³⁾	6.25	1.56	16.7	32.2	S 1	1	24.5	22.0	15	20	74	40	51	6.6	62	9	35	60	16	8	8	10	- ³⁾	M6	0.08
	25x50	12.50	3.14	15.4	31.7	S 1	1	24.1	21.5	15	20	74	40	51	6.6	62	10	58	125	16	8	10	10	48	M6	0.15
GSZ-25	32x5	0.83	0.21	21.5	49.3	E 1	1	31.5	28.9	20	25	82	50	65	9.0	80	10	55	15	17	5	-	12	62	M6	0.08
	32x10	1.67	0.42	33.4	54.5	E 1	1	32.7	27.3	20	25	82	53 ⁴⁾	65	9.0	80	16	69	20	17	5	-	12	62	M8x1	0.08
	32x20	3.33	0.83	29.7	59.8	E 1	1	31.7	27.9	20	25	82	53 ⁴⁾	65	9.0	80	16	80	35	17	5	-	12	62	M6	0.08
	32x40 ³⁾	6.67	1.67	14.9	32.4	S N ⁴⁾	1	30.9	28.3	20	25	82	53 ⁴⁾	68 ⁴⁾	7.0 ⁴⁾	80	14	45	70	17	5	7.5	16	- ³⁾	M6	0.08
GSZ-50	40x5	0.71	0.18	23.8	63.1	E 2	2	39.5	36.9	25	30	116	63	78	9	93	10	57	15	19	7	-	14	70	M6	0.08
	40x10	1.43	0.36	38	69.1	E 2	2	39.5	34.1	25	30	116	63	78	9	93	16	71	15	19	7	-	14	70	M8x1	0.08
	40x20	2.86	0.72	33.3	76.1	E 2	2	39.7	35.9	25	30	116	63	78	9	93	16	80	30	19	7	-	14	70	M8x1	0.08
	40x40	5.71	1.43	35	101.9	S 2	2	38.9	36.3	25	30	116	63	78	9	93	16	85	60	19	7	7.5	14	- ³⁾	M8x1	0.08
GSZ-100	50x10	1.11	0.28	68.7	155.8	E 2	2	49.5	44.1	40	45	160	75	93	11	110	16	95	20	30	8	-	16	85	M8x1	0.08
	50x20	2.22	0.56	60	136.3	E 2	2	49.5	44.1	40	45	160	85 ⁴⁾	103 ⁴⁾	11	125 ⁴⁾	22	95	40	30	8	-	18	95	M8x1	0.08
	50x10	1.11	0.28	112.1	338.5	E 2	2	50	43.6	40	45	160	75	93	11	110	16	107	20	30	8	-	16	85	M8x1	0.03
	50x20	2.22	0.56	112.4	214.7	E 2	2	50	41.1	40	45	160	85 ⁴⁾	103 ⁴⁾	11	120 ⁴⁾	16	125	40	30	8	-	16	95	M8x1	0.03
	50x40	4.44	1.11	84.7	143.1	E 2	2	50	41.1	40	45	160	85 ⁴⁾	103 ⁴⁾	11	120 ⁴⁾	16	125	80	30	8	-	16	95	M8x1	0.03
50x50 ⁴⁾	5.56	1.39	84.7	143.1	E 2	2	50	41.1	40	45	160	85 ⁴⁾	103 ⁴⁾	11	120 ⁴⁾	16	145	100	30	8	-	16	95	M8x1	0.03	

¹⁾ An extension may be required if a bellows or spiral spring is fitted.
²⁾ Dynamic load rating to DIN 69051 part 4 draft 1989.
³⁾ Round flange.

⁴⁾ Non-preferred design.
⁵⁾ Reduced play 0.02 mm available on request.
⁶⁾ Not to DIN 69051.

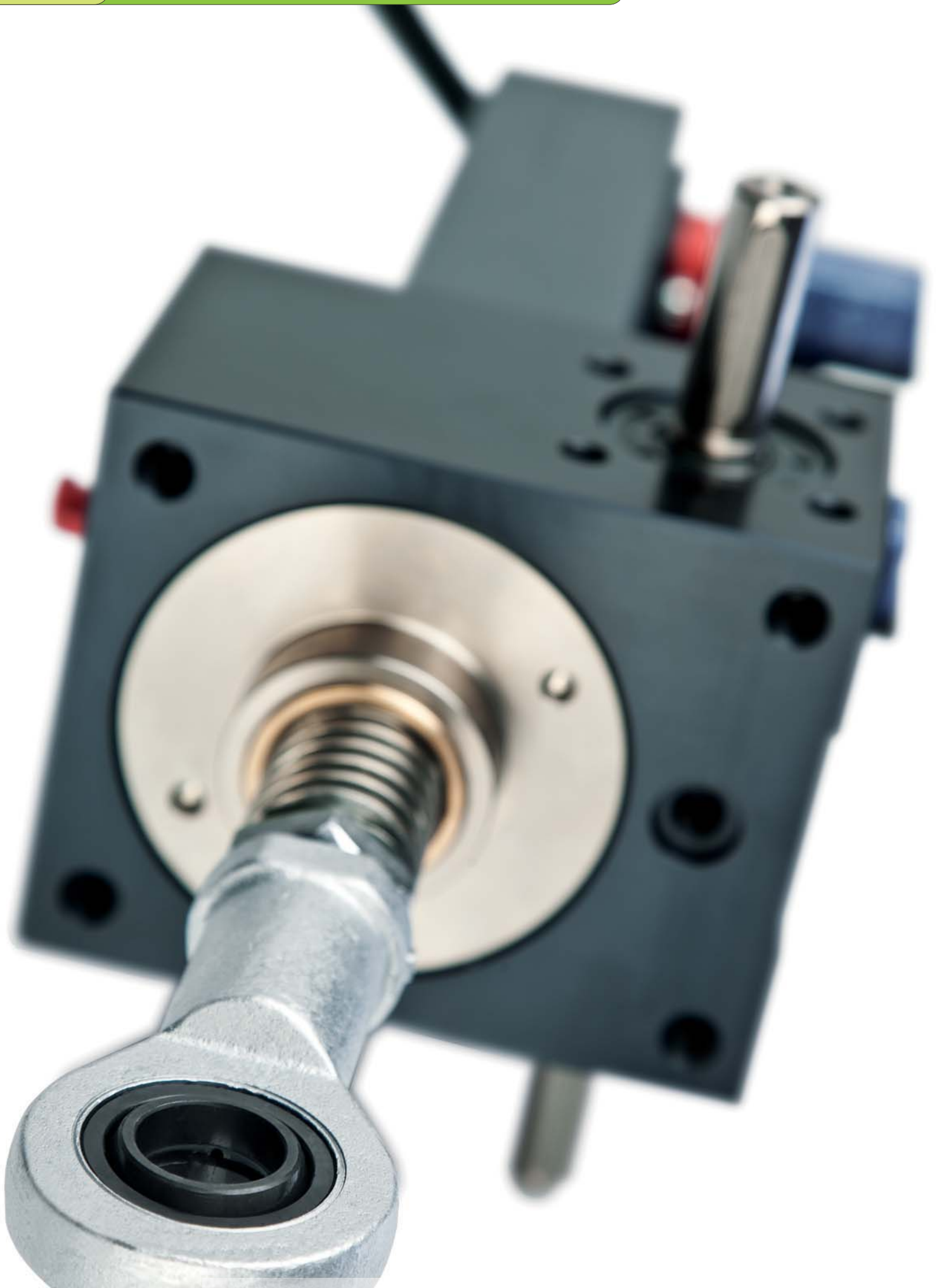

Safety nut SIFA



Function

A safety nut is designed for use where stripping and break up of the thread could cause a hazard to persons.

A safety nut can also provide protection for other equipment against the consequences of machine failures and downtimes.

Wear

Once the wear exceeds max. 25% of the screw pitch, the load nut (R) or the gearbox (S) must be replaced.

Monitoring

Wear and thread play should be checked and documented at regular intervals (depending on the duty cycle).

This allows the fitting of replacement parts to be planned ahead, reducing unscheduled system downtime.

Electrical monitoring

Electrical monitoring gives a signal when wear reaches approx. 25%. This signal can be displayed immediately at a central control point. Replacement of the worn parts can then be scheduled.

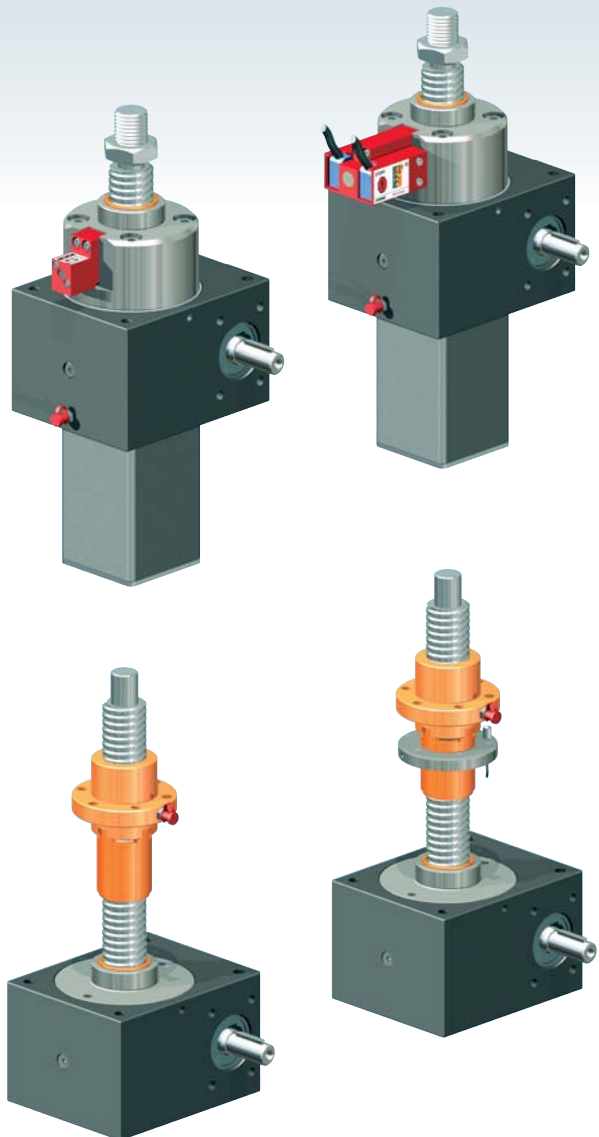

Screw jacks [TrØxP]	Pitch P [mm]	max. permissible wear/ thread play* (25% of P) [mm]
Tr16x4, Tr18x4, Tr20x4	4	1.0
Tr30x6	6	1.5
Tr40x7	7	1.75
Tr 55x9	9	2.25

* Identical for double pitch screws (same thread flank thickness)

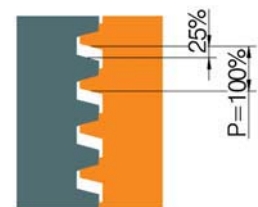

max. 25% wear



We have patents registered or pending for a range of functions and components.



SIFA-S translating screw

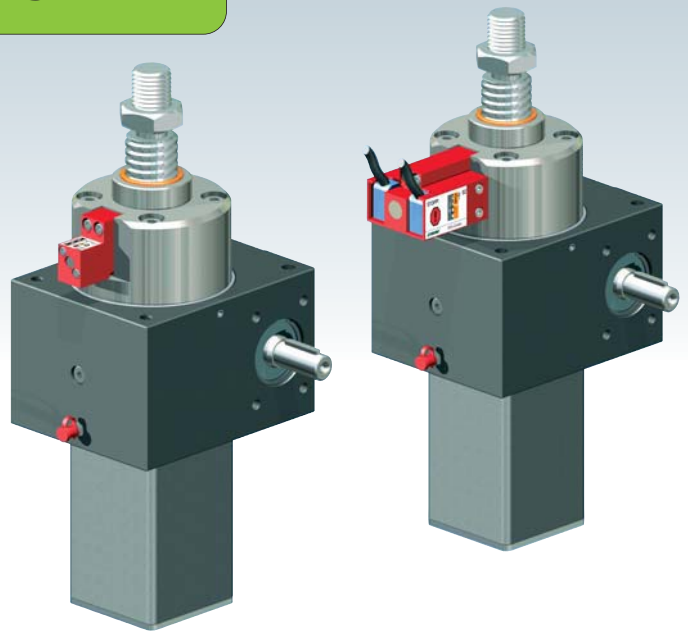

Function S version



The load is borne by the worm wheel via the screw. If the worm wheel screw thread wears through, the SIFA restrains the screw. The load remains supported.

Direction of loading, compressive and tensile
The new SIFA-S operates equally in both compressive and tensile directions of loading!

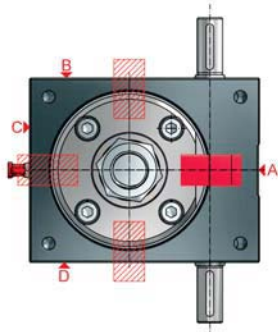
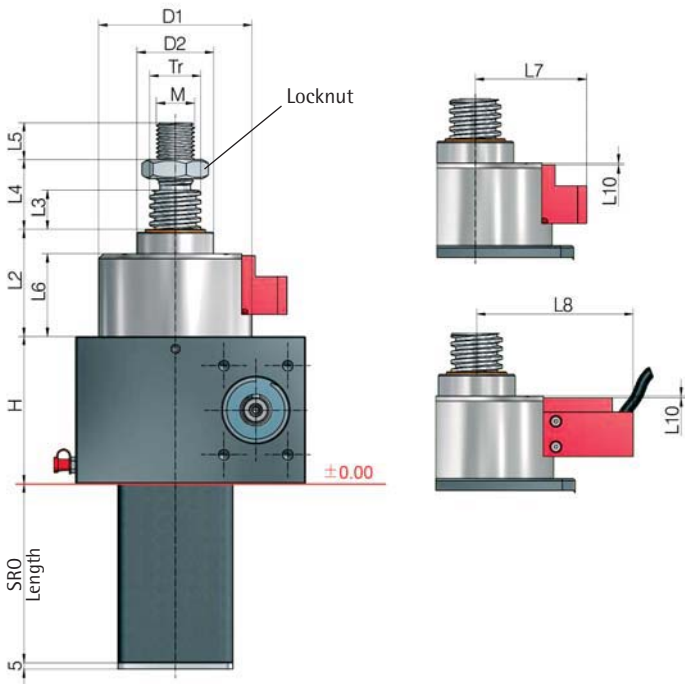

i further technical information: Page 75

Ordering code: GSZ-50-SN-SIFA-OP-A

Version
SN or SL

Monitoring
OP: visual
EL: electrical (wear, thread stripping)
ELV: only wear
ELD: only thread stripping
NO: without any monitoring

Position
A (standard), B, C or D
(can also subsequently be rotated steplessly through 360°)

Screw jack	Stroke travel/rev.		Tr thread	H	D1	D2	L2	L3 ¹⁾	L4 ¹⁾	L5	L6	L7	L8	L9	L10	M
	SN	SL														
GSZ-10	1	0.25	20x4	74	81	39	74	10	22	20	58	72	108	21	1	M14
GSZ-25	1	0.25	30x6	82	92	46	76	10	26	22	59	79	114	25	1	M20
GSZ-50	1	0.25	40x7	116	120	60	84	10	34	29	65	88	123	58	1	M30
GSZ-100	1	0.25	55x9	160	135	85	103	20	48	48	73	95	130	80	9	M36

¹⁾ See Section 8 for extension if bellows or spiral spring is fitted

SIFA-S, monitoring

Visual

Monitoring

Wear should be checked and documented at regular intervals. This allows the fitting operation for replacement to be planned in good time so as to avoid system downtime.

OK
Wear still <25% of P

CAUTION!
max. permissible wear reached –
Replace the gearbox

STOP!
Wear >25% or thread already worn through –
Stop operation immediately!

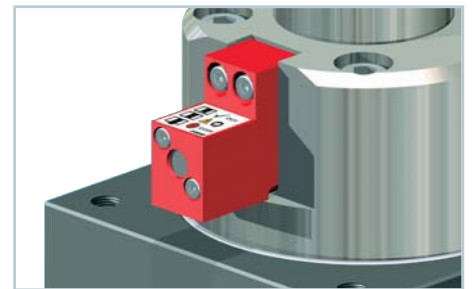
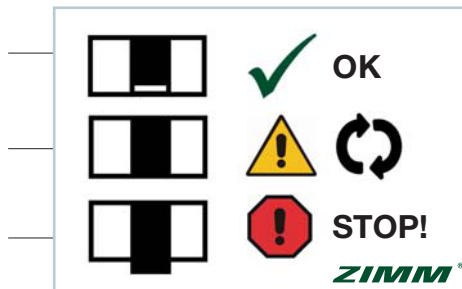

Electrical

WARNING! Switch S1
At 25% wear the limit switch S1 trips. The customer must detect this signal. This enables substitution to be planned well in advance and therefore prevents any unnecessary downtime.



STOP! Switch S2
If after the first signal operation of the jack continues, the nut will continue to wear until the thread is worn through. When the thread is worn through, the safety nut takes the load. The limit switch S2 trips. The customer must detect this signal and stop the system.

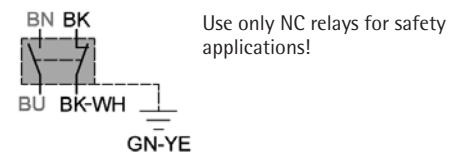

Without any monitoring

If the version used has no monitoring, the dimension A must be measured and documented when new, then regularly checked and documented.

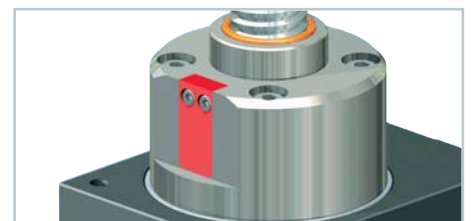
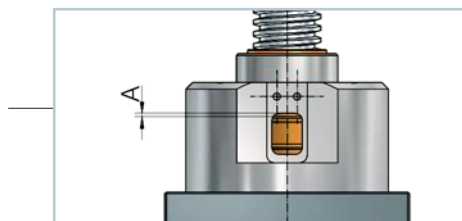



SIFA-R rotating screw

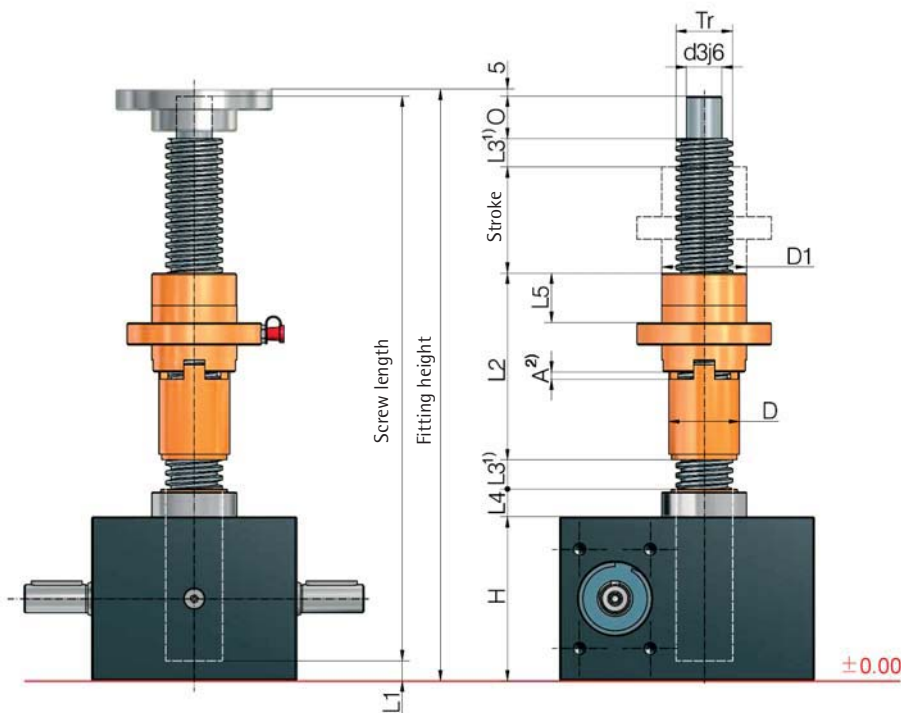
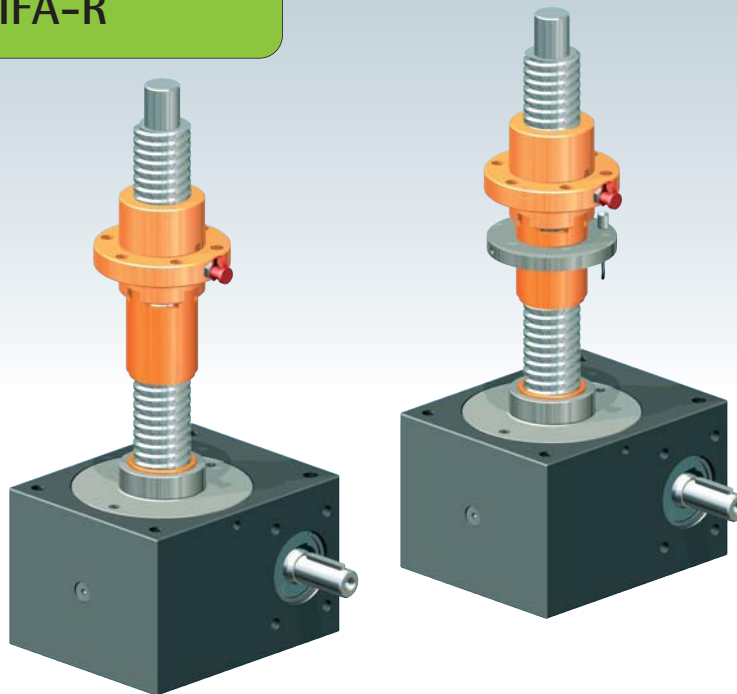

Function R version



The load is borne by the duplex nut. The safety nut runs alongside the duplex nut, bearing no load. If the nut thread is worn through due to wear, the SIFA takes the load on the duplex nut.

Direction of loading, compressive or tensile
A drawing showing the direction of loading is necessary in order to ensure the safety function. The SIFA-R operates in only one direction of loading.

- further technical information: Page 75
- see the respective screw jack page for all other dimensions
- see Section 4 for accessories
- SIFA in combination with self-aligning nut PM available on request

Screw jacks	Tr thread	H	D1	D	d3j6	O	L1	L2	L3 ¹⁾	L4	L5	A ²⁾
GSZ-2	16x4	50	26	22	10	12	3	70	10	11	20	3
GSZ-5	18x4	62	29	24	12	15	8	70	10	12	20	3
GSZ-10	20x4	74	39	28	15	20	8	84	10	16	20	3
GSZ-25	30x6	82	46	38	20	25	5	95	10	17	23	4
GSZ-50	40x7	116	60	50	25	30	13	133	10	19	36	4
GSZ-100	55x9	160	85	65	40	45	10	173	20	30	54	6

Make sure you fit it the right way up:

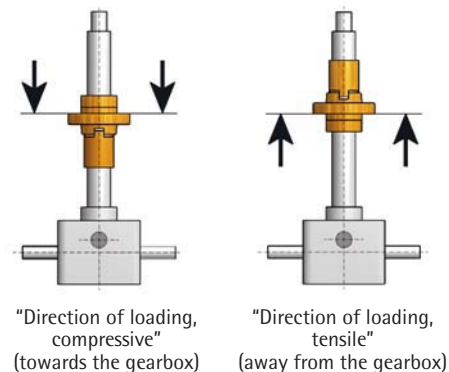

¹⁾ See Section 8 for extension if bellows or spiral spring is fitted
²⁾ approx. original setting, must be measured and documented by the customer, and referred to when checking

SIFA-R, monitoring

Visual

Dimension A is approx. the original setting. Dimension A must be measured and documented by the customer, and referred to when checking. This enables substitution to be planned well in advance and therefore prevents any unnecessary downtime. When the thread is worn through, take the equipment out of service immediately.

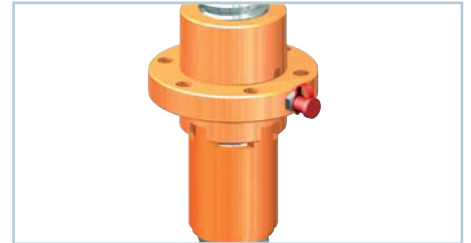
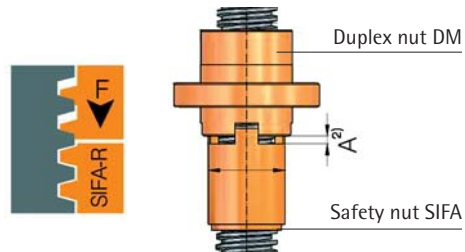

Electrical

The initiator must be set that it switches off when the load nut reaches 25% of the wear. This enables a replacement to be planned well in advance and therefore prevents any unnecessary downtime. When the thread is worn through, take the system out of service immediately.

