

INTECNO

power transmissions

D.C. BRUSHLESS MOTORS DRIVE BLD07-IT

Service Manual



INTECNO s.r.l.
Via Caduti di Sabbiuno n. 9/E
40011 Anzola Emilia (BO) - Italy
tel. 051.19985350 fax 051.19985360
www.intecno-srl.com

INDEX

| Description | Page |
|--|------|
| Safety and note | 3 |
| General characteristics | 4 |
| Size | 5 |
| Drive and connector Layout | 6 |
| Power connection | 7 |
| Signal connection | 9 |
| Output | 10 |
| Trimmer, Dip switch and LEDs | 11 |
| General description and how to size the power supply | 13 |
| Warnings, recommendations and maintenance | 14 |
| Diagnostic and trouble shooting | 15 |
| Guidelines for correct installation and CE declaration of conformity | 16 |

SAFETY AND NOTE

Users must take care that motion control equipment is capable of producing high forces and rapid movement so they must be used with attention, especially during the application program's development.

This motion control equipments are sold as end-users products to be installed only by skilled personnel, in accordance with all local safety laws and regulations. The device has to be enclosed such that any part is not be accessible while the system is powered on.

We strongly recommend to follow these recommendations in order to avoid wrong uses of the equipment that may make useless all the protections provided by the device.

Please read these notes carefully before powering up the drive:

It is very important to meet all applicable safety requirements during installation and operating of any motion control equipment. Any installer has to assume the responsibility to ensure that it complies all the relevant safety standards. Any installation, not meeting the safety requirements, may damage the equipment or injury the user.

This motion control equipment should be handled, installed, setted-up and maintained only by competent personnel expert and trained in the installation of motion control electronic equipment. Such technicians should be aware of potential electrical and mechanical hazards. Shall never be liable or have any responsibility if the products have been improperly stored, installed, used or maintained, or if the customer has permitted any unauthorized modifications, adjustments, and/or repairs to the products.

Simbols security standard:



Danger sign:

All the circuits in the Drive are potential sources of severe electrical shock, so follow these rules to avoid possible personal injury. Power off the drive and wait until all the leds are turned off before touching, removing, connecting or any other critical action. Never disconnect any connectors before powering down the drive.

Please read this manual before using the drive!!!!

This manual replaces and cancels any previous edition and revision

We reserve the right to make changes without notice.

GENERAL CHARACTERISTICS

This converter is a bidirectional regenerative drive, suitable for driving three-phase brushless motors at low voltage. PWM modulation with a carrier frequency of 20 kHz manages the power MOSFETs. Input voltage is from battery or regulated power supply. Adjustable output voltage for the selection of the motor speed, control and selection of direction, equipment ramps and the current limit.

| |
|--|
| Bidirectional regenerative drive |
| Power supply DC |
| 3 Leds for diagnostic |
| Protected against short circuit, min / max voltage, shortage of Hall cells |
| Motor thermal protection lxt |
| Removable connectors (signals and power) |
| Analog speed Signal: 0 +10Vdc, frequency, PWM. |
| 4 digital inputs, opto-isolated: Start/Stop, direction, 2 optional inputs |
| 2 outputs NPN, alarms and running frequency |
| Acceleration ramp adjustment |

| General characteristics | |
|-------------------------------------|---|
| Power Supply | 24-36 Vdc |
| Nominal Current | 7 A |
| Current regulation | 3/4/5,5/7 A with dip switch or trimmer |
| Ambient temperature | 0-40°C |
| Protection | Low voltage, high voltage, short circuit, shortage of Hall signals. lxt |
| LEDs | Power ON, FAULT, lxt |
| Digital outputs | 2 NPN open collector, max 50 V max 100 mA |
| Digital inputs | 4 opto-isolated |
| Analog speed reference input | External analog signal 0-10 Vdc or speed potentiometer 10 kOhm |
| Trimmer speed selection | On Board |
| Dip Switch of selection | 4 |
| IP | 10 |
| Mass (Kg) | 0,25 |

SIZE

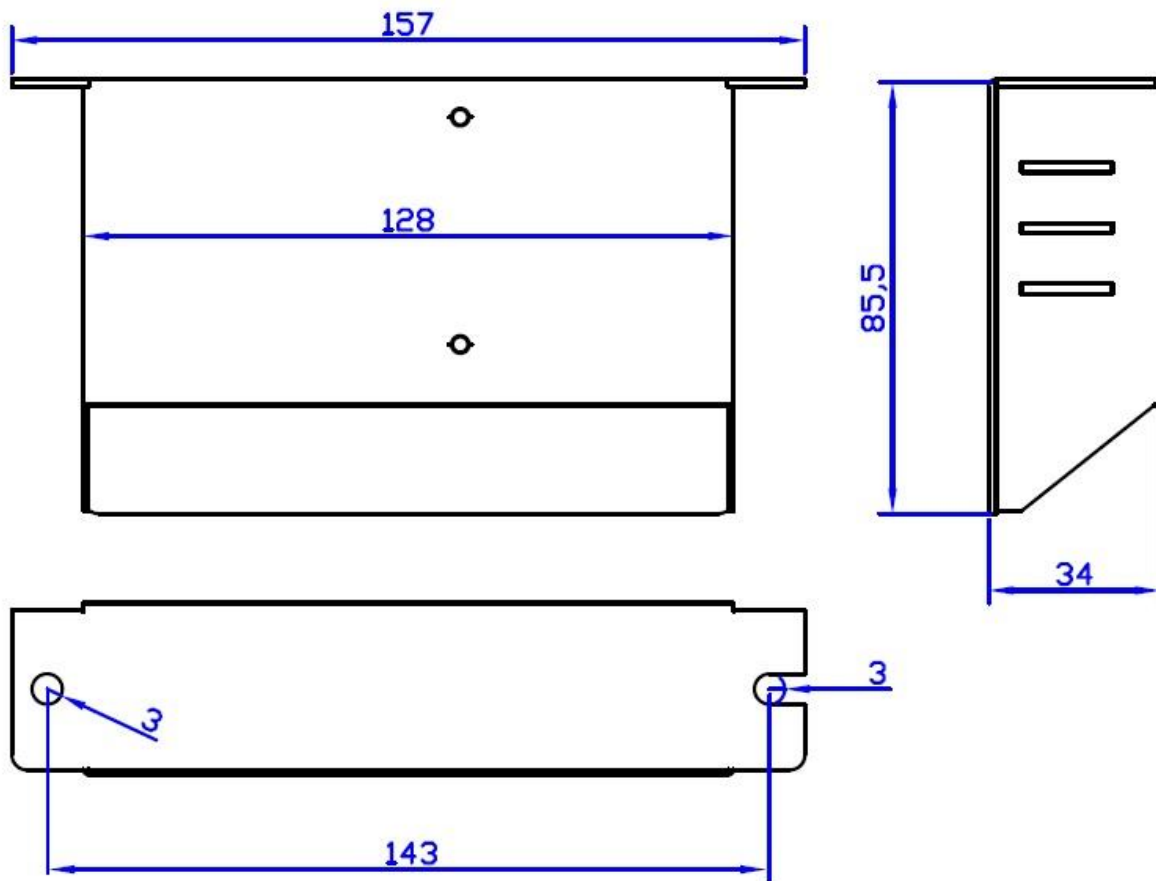

LAYOUT AND TERMINAL OF THE DRIVE

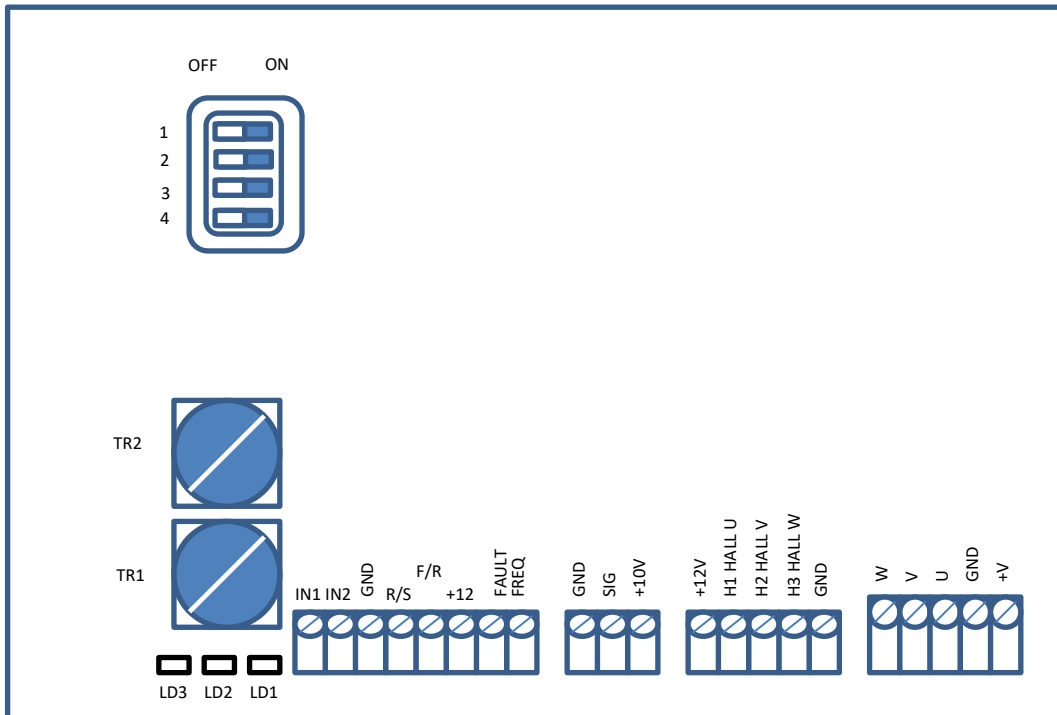

From right

Power connection:

- **+V** = power supply, positive
- **GND** = power supply, negative
- **U, V, W** = power motor phases

HALL connector:

- **+12V**= supply power of sensors
- **GND** = negative for power of the sensors
- **H1 Hall U, H2 Hall V, H3 Hall W** = the three phases of the hall sensors

Connector of potentiometer (or external analogue signal 0-10V):

- **GND, SIG, +10V** pins of the potentiometer. The cursor (variable pin) goes to the terminal SIG.

Connector I/O:

- **FREQ**= square wave output proportional to speed, NPN open collector signal.
- **FAULT** = alarm output, NPN open collector signal.
- **F/R** = selector of the direction of the rotation.
- **R/S** = start/stop operation command
- **GND**= common for the commands of R/S and F/R
- **IN1, IN2** = not used

DIAGRAM CONNECTIONS OF POWER SUPPLY AND MOTOR

Connections for motors: BL012.240 – BL018.240 – BL025.24E –
 BLS022.240 – BL032.240 – BLS043.240 – BL043.240

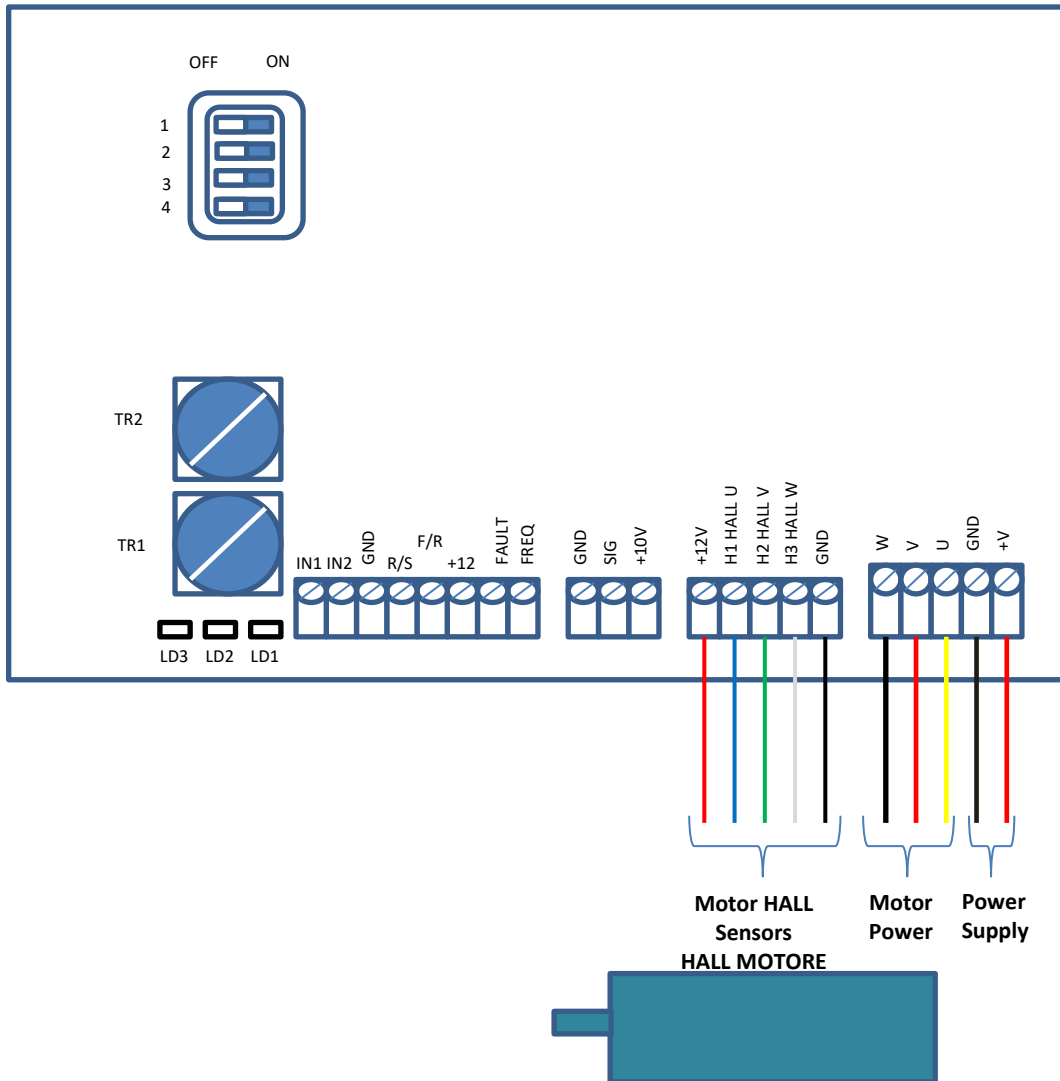

SUPPLY POWER:

lead the positive on +V, and the negative to GND.

Be careful, not to reverse the polarity, risk of damage to the board.

MOTOR POWER:

The phases, U = yellow, V = red, W = black.

HALL MOTOR:

The phases, +12V = red, HU= blue, HV = green, HW = white, GND = black

This color sequence must be followed.

DIAGRAM CONNECTIONS OF POWER SUPPLY AND MOTOR

Connections for motor: BL005.240

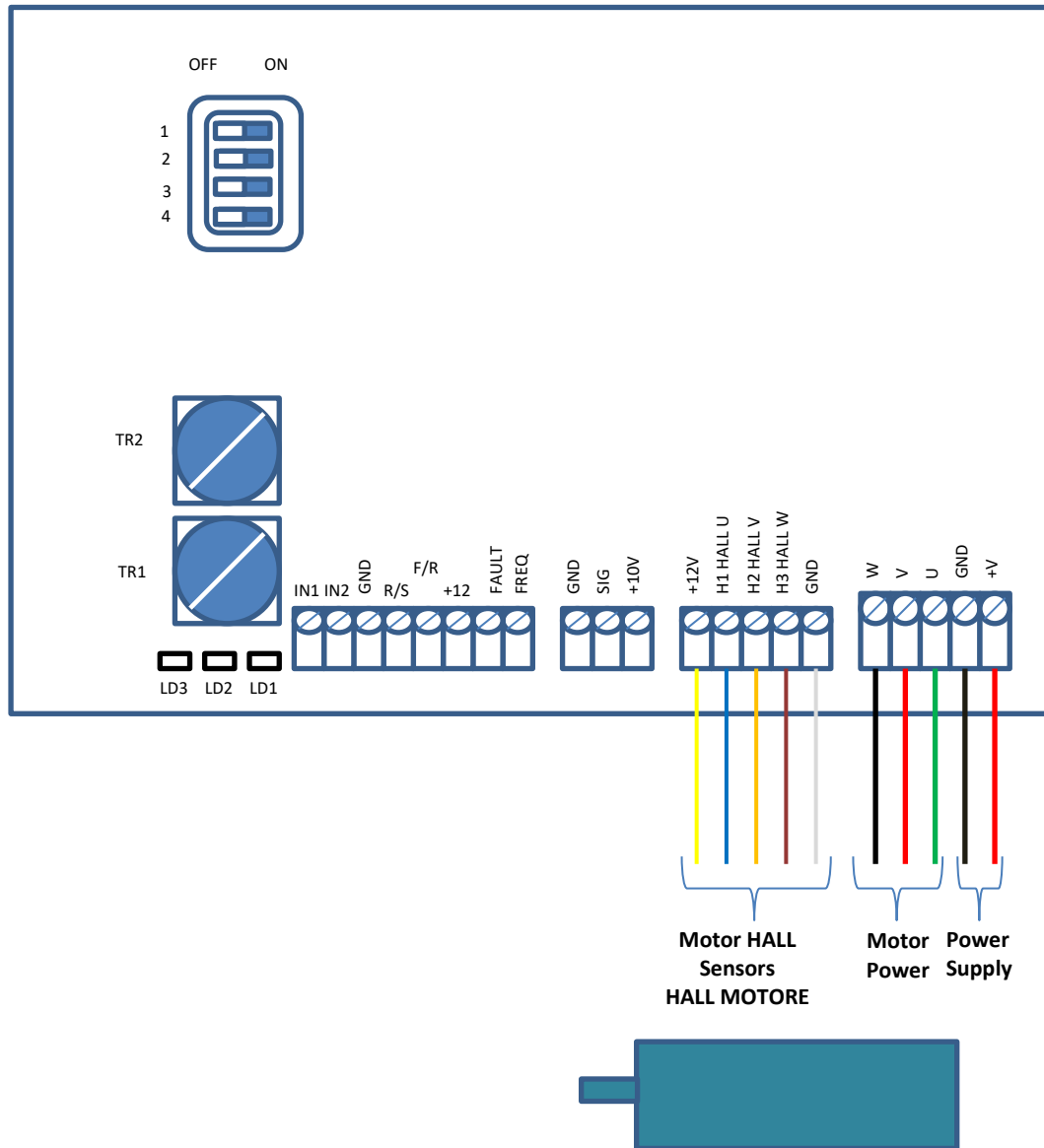

SUPPLY POWER:

lead the positive on +V, and the negative to GND.

Be careful, not to reverse the polarity, risk of damage to the board.

MOTOR POWER:

The phases, U = green, V = red, W = black.

HALL MOTOR:

The phases, +12V = yellow, HU= blue, HV = orange, HW = brown, GND = white.

This color sequence must be followed.

SIGNAL CONNECTION

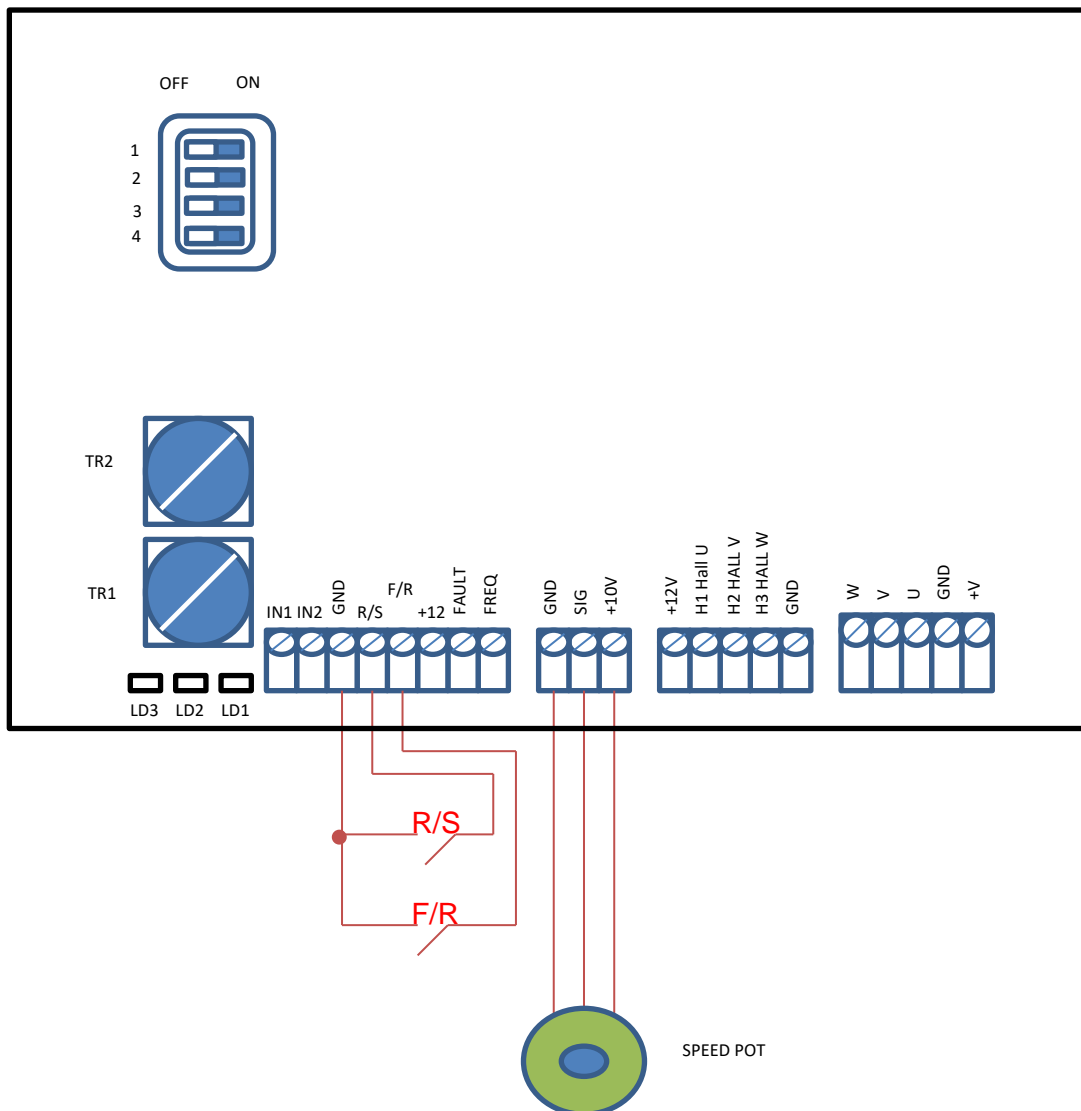

Connect the potentiometer as shown in diagram. Be careful: the cursor (variable pin) must be connected to SIG. in case of analog power supply 0/+10 V, the reference goes to GND and the signal to SIG.

Closing the R/S terminal to GND for managing the run and stop operations.
Closing the F/R terminal to GND to determine the direction selection.

! DANGER: This command forces the run in reverse direction immediately without the needing to open and close again the R/S.

OUTPUT

There are two NPN outputs open collector. Can be used as open collector outputs (if equipped with PLC which accepts the NPN output), or with a resistance $R = 10\text{ KOHM}$ (one for each output) to get a voltage signal. 50 V & 100 mA NPN outputs, MAX.

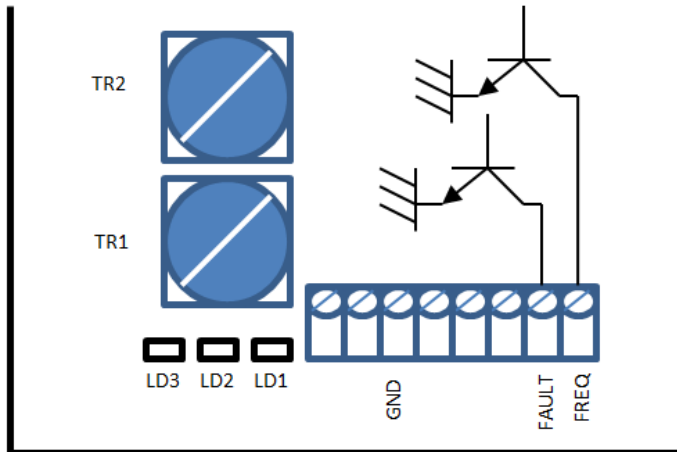

Note: The FAULT output is normally closed. It opens when an alarm happens. In the case of the pull up resistor, the alarm output is a voltage (+12 Vdc signal).

The signal is output at the point of the arrow (see diagram below).

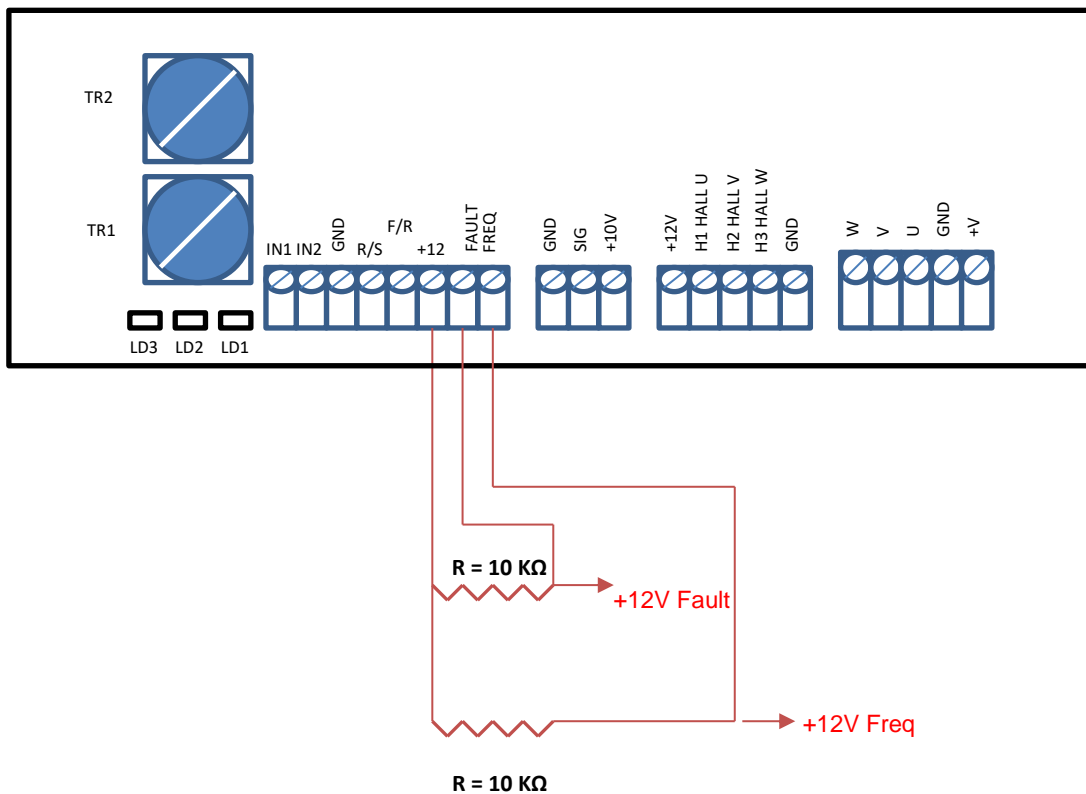

DIP SWITCH, TRIMMER and LEDs

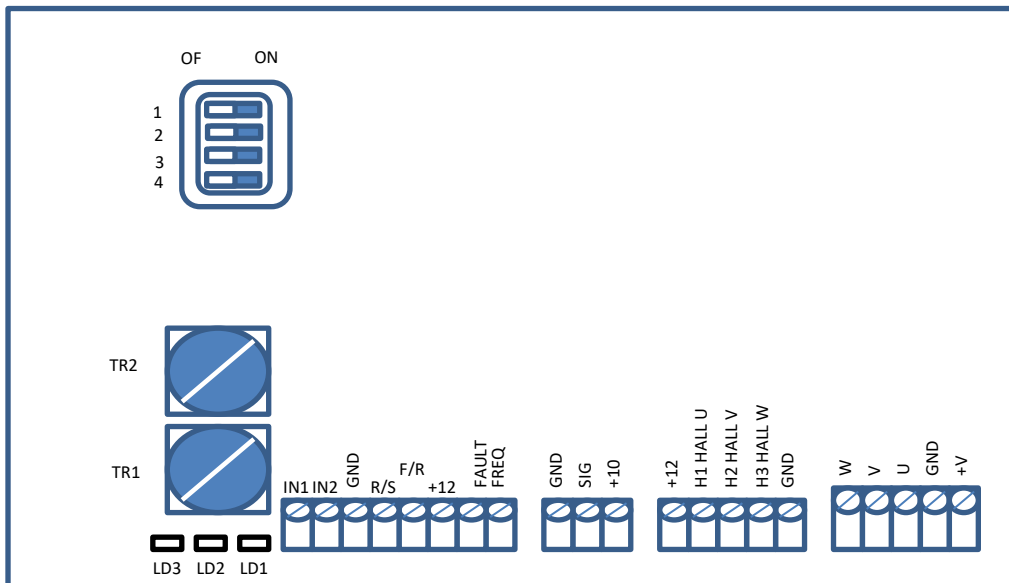

| Dip switch | Descrizione |
|--|---|
| 1 Selecting input for speed reference | OFF = speed controlled by on board trimmer (TR1). ON = speed controlled by external potentiometer or 0-10V analog signal |
| 2 Speed fine tuning function | OFF = enabled ON = disabled |
| 3 Acceleration/deceleration selection | OFF = fast ramps (about 0.1 seconds) ON = slow ramps (about 1.0 seconds) |
| 4 Motor polarity selection | OFF = 4 poles motors ON = 8 poles motors |

| Motor | Poles | Dip Switch 4 | Nom. Current [A] | Motor Voltage [V] |
|-------------|-------|--------------|------------------|-------------------|
| BL 005.240 | 4 | Off | 1,0 | 24 |
| BL 012.240 | 8 | On | 3,5 | 24 |
| BL 018.240 | 8 | On | 5 | 24 |
| BL 025.24E | 8 | On | 6,6 | 24 |
| BL 032.240 | 4 | Off | 5 | 24/36 |
| BL 043.240 | 4 | Off | 6,8 | 24/36 |
| BLS 022.240 | 4 | Off | 3,7 | 24/36 |
| BLS 043.240 | 4 | Off | 6,0 | 24/36 |

Trimmers

TR1 = speed selection trimmer (it rises in clockwise rotation)

TR2 = trimmer for current limitation (it rises in counter-clockwise rotation)

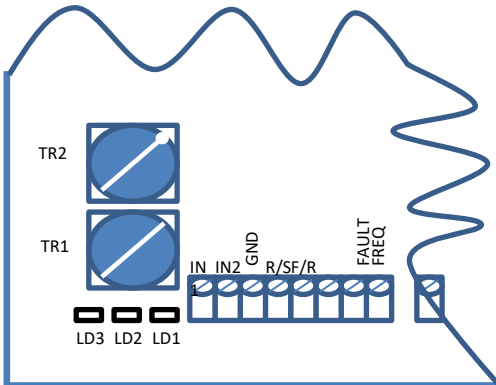

Use of TRIMMER for current limitation (TR2):

The trimmer limits the supply of the current, in order to match the current to the motor's rated one. To set correctly: adopt a current amperometer (to be placed on the positive supply), rotate fully counterclockwise this trimmer load the motor, up to read the rated value on the amperometer. Afterwards, turn the trimmer clockwise until you see a light flashing but persistent.

Indicative positions of the trimmer:

| 3A | 4A | 5.5A | 7A |
|----|----|------|----|
| | | | |

LEDs

LED1 = green, POWER ON (voltage is present)

LED2 = red, active alarm

LED3 = yellow, it has two functions: during normal operation it indicates the current limit. In case of alarm blinks according to precise coding to show the type of alarm active. (see pag. 15)

There are on board other two LEDs that light up at the closing of the contacts of R/S and F/R.

GENERAL DESCRIPTION

- Supply the board to pins (+ V, GND) with stabilized voltage 24 Vdc or 36 Vdc depending on the motor.
- Connect the pins of the motor to the U-V-W power contacts in the given order. WARNING: RESPECT THE SEQUENCE!
- Connect the Hall motor contacts signal pins H1 Hall U - H2 Hall V - H3 Hall W in the given order: WARNING: RESPECT THE SEQUENCE.
- Run command: close with an external contact pin R / S to GND. OPEN to command a STOP.
- Selection of the direction: close with an external contact pin F / R to GND. NOTE: This contact produces immediate reversal of motion and does not wait for a new run command. WARNING!
- FAULT output: it switches due to an alarm, to show to the user or the PLC the status of the drive. Using a pull-up resistor (as per this manual) is possible to switch from the open collector signal (=simple open or closed contact) to a voltage signal: 0 Vdc = ready; 12 Vdc = alarm on.
- Output FREQ (reference motor speed): this contact gets out a frequency signal proportional to the motor speed. It is a signal with a duty cycle of about 50% and resolution 6 / rev. Using a pull-up resistor (as per this manual) is possible to switch from the open collector signal (=simple open or closed contact) to a voltage signal. 0 Vdc ÷ 12 Vdc.
- Speed reference: it gives a speed reference to the motor, that is, how fast you want it to run. The selection of Dip 1 is used to control the speed via the TR1 trimmer on board. In this way any external devices is requested. Dip 1 allows you also to select the reference from an external potentiometer by potentiometer from 10 KOhm. Or analog signal 0-10 Vdc. The signal is proportional, that is, increase the signal to increase the speed of the motor.

HOW TO SIZE THE POWER SUPPLY

The drive requires stabilized DC voltage.

The level is 24 or 36 Vdc. The selection of the voltage level depends on the nominal value in the motor plate.

Please remember that reducing voltage the motor becomes depowered.

You can supercharge a few volts, especially if you are concerned that there is a significant drop on the supply lines.

Two solutions are possible:

- stabilized power supply
- transformer, bridge rectifier, smoothing capacitor

The solution with the transformer, bridge rectifier, smoothing capacitor is more suitable in applications with regenerative loads.

Fuses:

Recommended size is 2 times the rated current of the motor fuse with delayed trip and in any case not exceed 12 A, to be assembled in series with the supply.

WARNINGS, RECOMMENDATIONS AND MAINTENANCE

- Power the driver only when the motor has been mounted safely. Beware of moving parts: DANGER.
- Pay attention to the key of the motor, in case you run the motor.
- Do not reverse the power polarity of the drive: risks damaging.
- You must follow the color sequence of the power and signal cables, as per this manual. Caution: danger of damaging.
- Apply the drive possibly vertically. It is suggested to mount on a metal base plate to improve heat dissipation. Keep the drive in an electrical panel, reasonably ventilated, if possible, or at least with open space all around.
- Avoid dusty and humid environments.
- The drive is NOT suitable for use in explosive or dangerous atmosphere.
- It is not recommended to cut the line between drive and motor, and if it must be done, open the line when motor is not running. The risk is to damage the power transistors.
- Avoid contamination with dirt, dust, water and metal debris.
- The drive is sensitive to electrostatic discharge

For questions or uncertainties, please contact Intecno srl.

MAINTENANCE:



after a long period of storage, it is recommended to power the drive with low load for a few minutes.

In case of replacement of the motor verify the DIP Switch settings and the current limit.

DIAGNOSTIC AND TROUBLE SHOOTING

Alarms mean certain dangerous conditions (for the drive or the mechanism) that the drive is able to verify and, in the case, to interrupt operation.

LED 2 (red) indicates alarm in progress, while the LED 3 (yellow), is used to identify the type of alarm; depending on the number of flashes it indicates a different problem.

| N° Flashes | Description | Possible solutions (in order) |
|------------|--|--|
| 1 | The sequence of the Hall signals is not correct and the drive is not able to determine the correct sequence of the phases. | <ul style="list-style-type: none"> • Check wire (colors) sequence of the Hall, they must be exactly as per the manual. • Check that the cables are properly inserted into the connector. • Contact technical department Intecno srl. |
| 2 | Short circuit. The drive is delivering the current in an excessive way. | <ul style="list-style-type: none"> • Recheck that the power and signal cables are properly connected (according to the colors shown in this manual). • Check that the motor is free to rotate. • Check that the load on the motor does not exceed the motor nameplate data (including radial loads of potential pulleys and belts). • Disconnect the motor and try to run without the motor, if the alarm persists. • Contact technical department Intecno srl. |
| 3 | too low voltage level (<18 V) | <ul style="list-style-type: none"> • Check the quality of power source. • Check the voltage level of the source. • Make sure the power supply is adequate. • Ensure proper cable section and length. |
| 4 | too high level voltage (> 55V) | <ul style="list-style-type: none"> • Check the voltage level of the power source. • Check that the load is not inertial one, in which case make longer the deceleration ramp. |
| 5 | Sudden motor block | <ul style="list-style-type: none"> • Check the mechanics of the application |
| 6 | Power failure Hall | <ul style="list-style-type: none"> • Check the connection of the signals and power Hall and the connection of the connector. |

Problematic Vibrations:

| Vibrations | Possible solutions |
|--|--|
| the motor vibrates visibly and it also absorbs a lot of current even together with an empty motor. | carefully check the sequence of the signal cables and power, as it is in the manual. |

GUIDELINES FOR CORRECT INSTALLATION

The BLD07IT drive is a product classified in Category C3.

The product complies with **EC rules** if it is subject to the following guidelines assembly:

- installation of an atmospheric discharge device on the power line of the type approved according to **EN 61643-11** and **EN 61643-1** with discharge for at least 2.5 kV impulse voltage (suppressor lightning).
- Earth the heatsink at the point indicated by printed symbol; it's done to eliminate static discharge, which can damage the drive.
- Maximum length of Power supply cables 3 m.
- Maximum length of the signal and connection cables 3 m.

CE DECLARATION OF CONFORMITY

The BLD07IT complies with the essential requirements of Directive:

- **EMC 2014/30/UE**
- **ROHS 2011/65/UE**

Applicable to the product. Furthermore, the object of the declaration described above is in conformity with the relevant Union harmonization legislation:

- **EN 61800-3:2004 +A1:2012**

