

# Ezi-SERVO<sup>®</sup>

## Closed Loop Stepping System

- Stepping Motor with High Resolution Encoder
- Closed-Loop Stepping System
- High Precision Position Control
- Low Heat Generation / High Torque
- EtherCAT, Ethernet, CC-Link Supported

**HS**

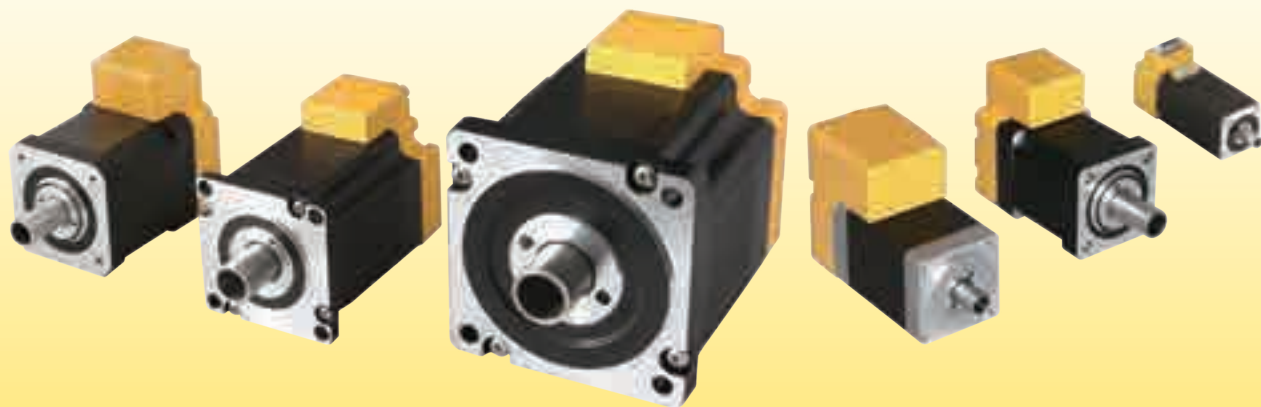

*Fast, Accurate, Smooth Motion*

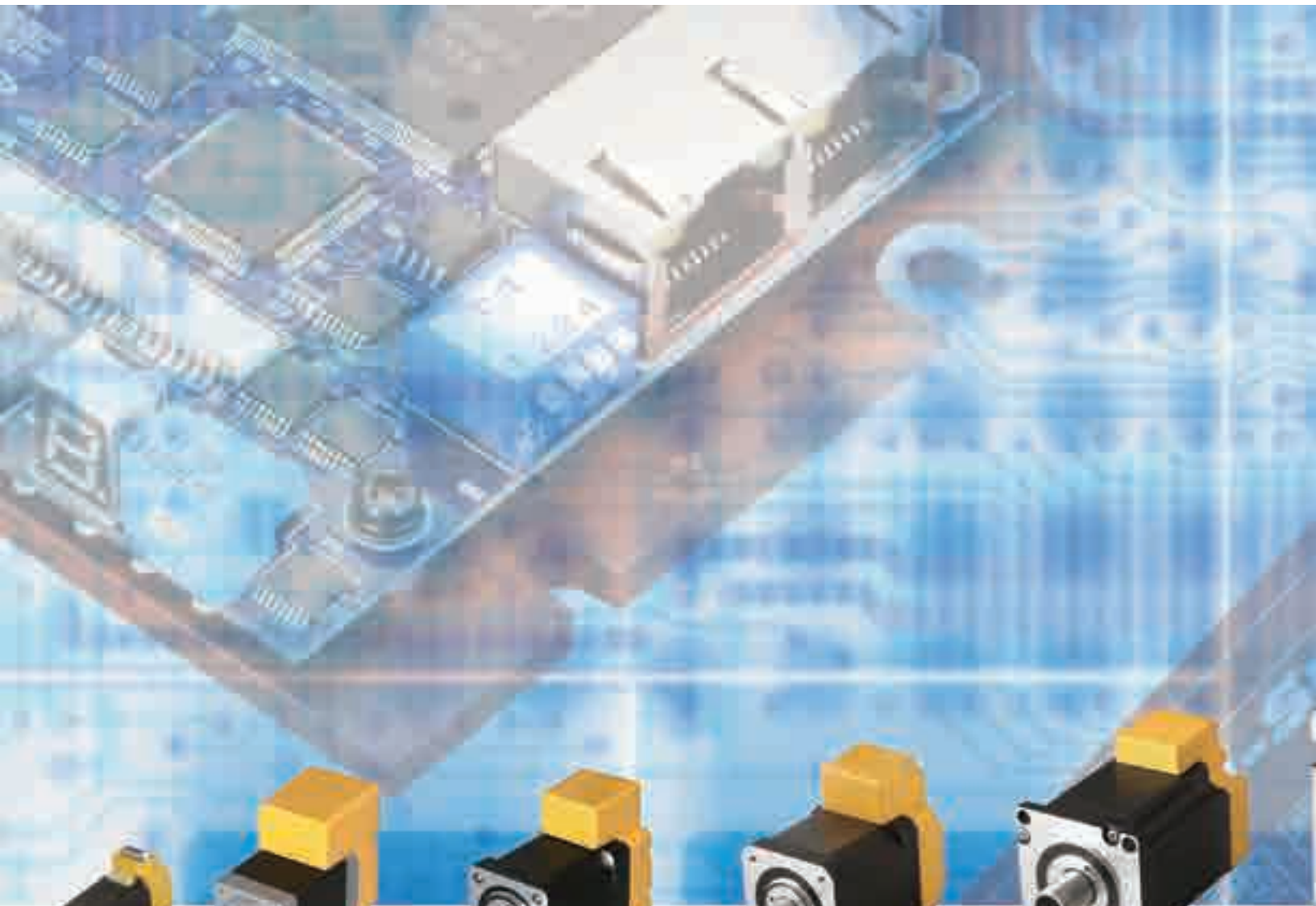

*Fast, Accurate, Smooth Motion*

# **Ezi-SERVO<sup>®</sup> HS**

**Closed Loop Stepping System**



## 1 Hollow Shaft Motor

A hollow shaft motor is a type of product in which a cable or tube can be inserted into the shaft because the motor shaft is hollow. The use of this motor allows the device to be miniaturized and lightweight, thus significantly reducing the cost.

Motor Size	Hollow Shaft Inner Diameter [mm]	Hollow Shaft Outer Diameter [mm]
20mm	Ø3	Ø5
28mm	Ø5	Ø7
35mm	Ø8	Ø10
42mm	Ø8	Ø10
56mm	Ø12	Ø15
86mm	Ø16	Ø20



## 2 High Resolution

The unit of the position command can be divided precisely. (Max. 20,000 pulses/revolution)

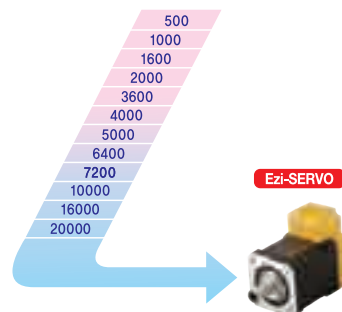

## 3 Closed-Loop System

Ezi-SERVO is an innovative Closed-Loop System that utilizes a high-resolution motor mounted encoder constantly to monitor the current position. The encoder feedback allows the Ezi-SERVO to update the current position. It allows the Ezi-SERVO drive to compensate for the loss of position, ensuring accurate positioning. For example, due to a sudden load change, a conventional stepping motor and drive could lose a step but Ezi-SERVO automatically correct the position by encoder feedback.

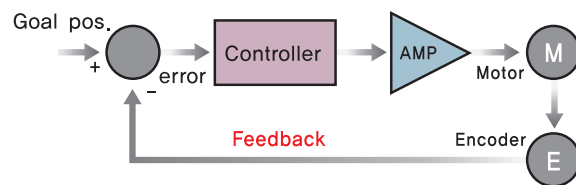

## 4 Various Network Supported

Ezi-SERVO HS is a unit product that combines a hollow shaft motor and various drives, and can be connected to a host controller through field networks such as EtherCAT, Ethernet, and CC-Link. For Ezi-SERVO II Plus-E products, Windows 7/8/10 motion library (DLL) is provided.

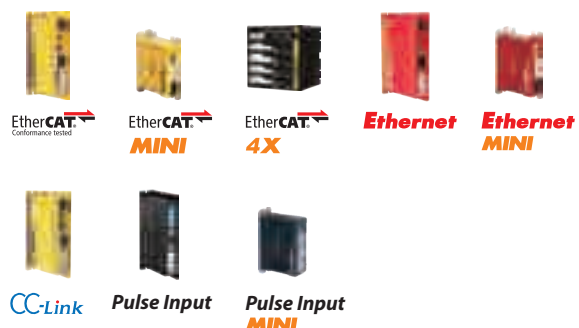

## 5 Tuning Not Required

To ensure machine performance, conventional servo systems require the adjustment of its servo's gains as an initial crucial step. Even systems that employ auto-tuning require manual tuning after the system is installed. Ezi-SERVO employs the best characteristics of the stepping motor to eliminate the need of tedious gain tuning required for conventional closed-loop servo systems. Ezi-SERVO is especially well suited for low-rigidity loads (e.g., a belt and pulley system) that sometimes require conventional servo systems to use the additional bulky and expensive gearbox.

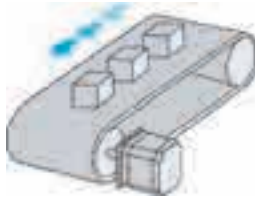

## 6 Low Heat Generation / Energy Savings

(Motor Current Control according to load)

Ezi-SERVO automatically controls motor current according to load. Ezi-SERVO reduces motor current when motor load is low and increases motor current when load is high. By optimizing the motor current, motor heat can be minimized and energy can be saved.

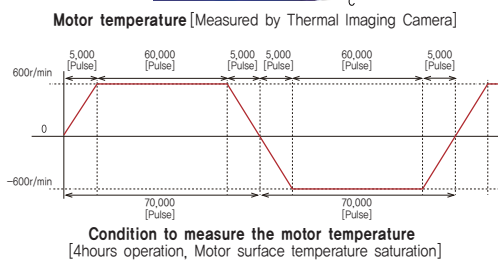
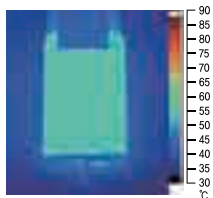

Example of the Motor Current Control according to load

## 7 High Torque

(Motor Voltage Increasing and Motor Current Setting)

Ezi-SERVO boosts the voltage supplied to the motor by internal DC-DC Converter. The torque at the high speed is increased. In addition, it is possible to set the Run Current up to 150%, whereby the torque at low speed is increased. Torque can be improved by about 30% over the entire speed range.

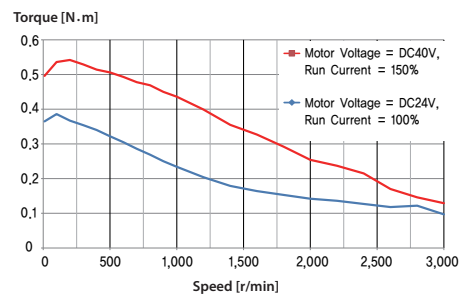

※ The torque at low speed and high speed is improved about 30%.

Measured Condition : Drive = Ezi-SERVO-HS-PE-42L  
Motor Voltage = DC40V  
Input Voltage = DC24V

## 8 No Hunting

Ezi-SERVO utilizes the unique characteristics of stepping motors and locks itself into the desired target position, preventing vibration and eliminating Null Hunt which happens to the conventional servo systems. This feature is especially useful in applications such as vision systems in which system oscillation and vibration could be a problem.

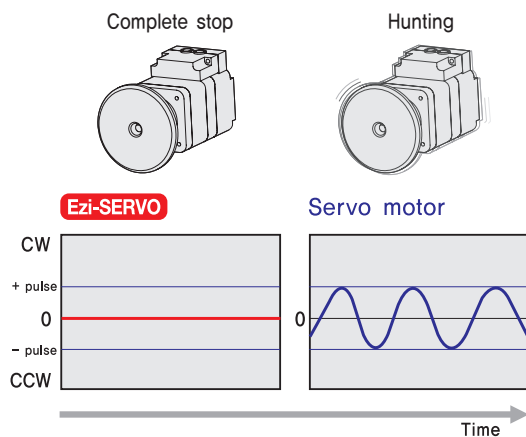

## 9 Smooth and Accurate Operation

Ezi-SERVO is a high-precision servo drive, using a high-resolution encoder. Unlike a conventional Microstep drive, the on-board high performance MCU (Micro Controller Unit) performs vector control and filtering, producing a smooth rotational control with minimum ripples.

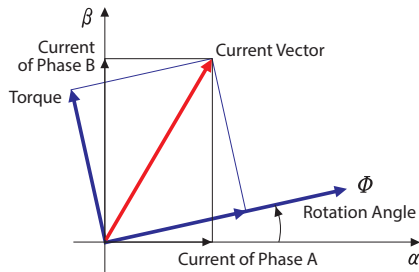

## 12 High Speed

The Ezi-SERVO operates well at high speed without the loss of synchronism or positioning error. Ezi-SERVO's ability to monitor current position continuously enables the stepping motor to generate high torque, even under a 100% load condition.

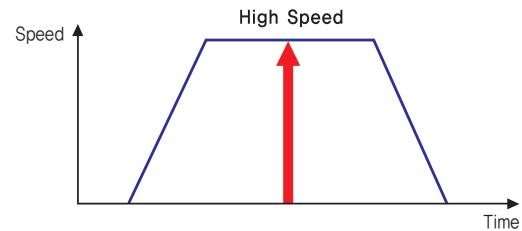

## 10 High Response

Similar to conventional stepping motors, Ezi-SERVO instantly synchronizes with command pulses providing fast positional response. Ezi-SERVO is the optimal choice when zero-speed stability and rapid motions within a short distance are required. Traditional servo motor systems have a natural delay called settling time between the command input signals and the resultant motion because of the constant monitoring of the current position.

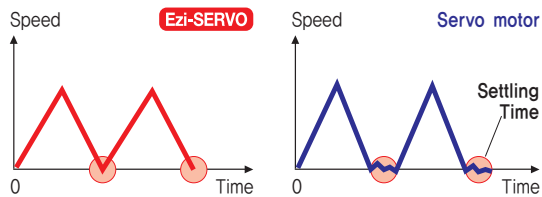

## 11 High Torque/Continuous Operation

Compared with common step motors and drives, Ezi-SERVO motion control systems can maintain a high torque state over relatively long period of time. This means that Ezi-SERVO continuously operates without loss of position under 100% of the load. Unlike conventional Microstep drives, Ezi-SERVO exploits continuous high torque operation during high speed motion due to its innovative optimum current phase control.

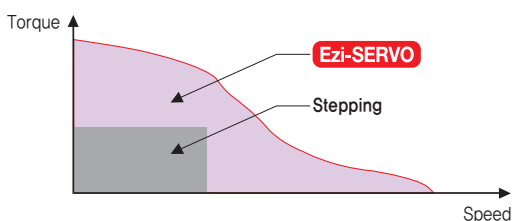

## 13 Examples



## ● Ezi-SERVO HS Part Numbering

**Ezi-SERVO-HS-ST-56L-A**

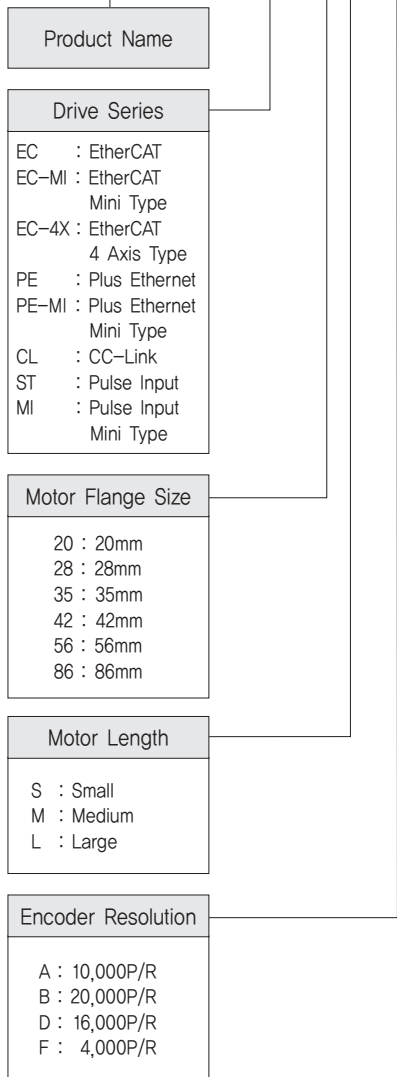

## ● Applicable Product Series

Product	Specifications
Ezi-SERVO II EtherCAT	EtherCAT Based Product
Ezi-SERVO II EtherCAT MINI	EtherCAT Based Mini Type Product
Ezi-SERVO II EtherCAT 4X	EtherCAT Based 4 Axis Type Product
Ezi-SERVO II Plus-E	Ethernet Based Product
Ezi-SERVO II Plus-E MINI	Ethernet Based Mini Type Product
Ezi-SERVO II CC-Link	CC-Link Based Product
Ezi-SERVO ST	Pulse Input Type Product
Ezi-SERVO MINI	Pulse Input Mini Type Product



Ezi-SERVO II EtherCAT  
(EtherCAT)

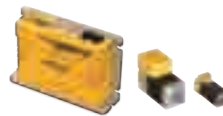

Ezi-SERVO II EtherCAT MINI  
(EtherCAT Mini Type)



Ezi-SERVO II EtherCAT 4X  
(EtherCAT)



Ezi-SERVO II Plus-E  
(Ethernet)



Ezi-SERVO II Plus-E MINI  
(Ethernet Mini Type)



Ezi-SERVO II CC-Link  
(CC-Link)



Ezi-SERVO ST  
(Pulse Input Type)



Ezi-SERVO MINI  
(Pulse Input Mini Type)

## ● Combination of Hollow Shaft Motor and Drive

### · Ezi-SERVOII EtherCAT

Unit Part Number	Motor Model Number	Drive Model Number
Ezi-SERVO-HS-EC-20M-F	HSE-20M-F	EzS2-EC-HS20M-F
Ezi-SERVO-HS-EC-20L-F	HSE-20L-F	EzS2-EC-HS20L-F
Ezi-SERVO-HS-EC-28SM-D	HSE-28SM-D	EzS2-EC-HS28S-D
Ezi-SERVO-HS-EC-28MM-D	HSE-28MM-D	EzS2-EC-HS28M-D
Ezi-SERVO-HS-EC-35MM-D	HSE-35MM-D	EzS2-EC-HS35M-D
Ezi-SERVO-HS-EC-35LM-D	HSE-35LM-D	EzS2-EC-HS35L-D
Ezi-SERVO-HS-EC-42S-A	HSE-42S-A	EzS2-EC-HS42S-A
Ezi-SERVO-HS-EC-42S-B	HSE-42S-B	EzS2-EC-HS42S-B
Ezi-SERVO-HS-EC-42L-A	HSE-42L-A	EzS2-EC-HS42L-A
Ezi-SERVO-HS-EC-42L-B	HSE-42L-B	EzS2-EC-HS42L-B
Ezi-SERVO-HS-EC-56S-A	HSE-56S-A	EzS2-EC-HS56S-A
Ezi-SERVO-HS-EC-56S-B	HSE-56S-B	EzS2-EC-HS56S-B
Ezi-SERVO-HS-EC-56M-A	HSE-56M-A	EzS2-EC-HS56M-A
Ezi-SERVO-HS-EC-56M-B	HSE-56M-B	EzS2-EC-HS56M-B
Ezi-SERVO-HS-EC-86M-A	HSE-86M-A	EzS2-EC-HS86M-A
Ezi-SERVO-HS-EC-86M-B	HSE-86M-B	EzS2-EC-HS86M-B

### · Ezi-SERVOII Plus-E

Unit Part Number	Motor Model Number	Drive Model Number
Ezi-SERVO-HS-PE-20M-F	HSE-20M-F	EzS2-PE-HS20M-F
Ezi-SERVO-HS-PE-20L-F	HSE-20L-F	EzS2-PE-HS20L-F
Ezi-SERVO-HS-PE-28SM-D	HSE-28SM-D	EzS2-PE-HS28S-D
Ezi-SERVO-HS-PE-28MM-D	HSE-28MM-D	EzS2-PE-HS28M-D
Ezi-SERVO-HS-PE-35MM-D	HSE-35MM-D	EzS2-PE-HS35M-D
Ezi-SERVO-HS-PE-35LM-D	HSE-35LM-D	EzS2-PE-HS35L-D
Ezi-SERVO-HS-PE-42S-A	HSE-42S-A	EzS2-PE-HS42S-A
Ezi-SERVO-HS-PE-42S-B	HSE-42S-B	EzS2-PE-HS42S-B
Ezi-SERVO-HS-PE-42L-A	HSE-42L-A	EzS2-PE-HS42L-A
Ezi-SERVO-HS-PE-42L-B	HSE-42L-B	EzS2-PE-HS42L-B
Ezi-SERVO-HS-PE-56S-A	HSE-56S-A	EzS2-PE-HS56S-A
Ezi-SERVO-HS-PE-56S-B	HSE-56S-B	EzS2-PE-HS56S-B
Ezi-SERVO-HS-PE-56M-A	HSE-56M-A	EzS2-PE-HS56M-A
Ezi-SERVO-HS-PE-56M-B	HSE-56M-B	EzS2-PE-HS56M-B
Ezi-SERVO-HS-PE-86M-A	HSE-86M-A	EzS2-PE-HS86M-A
Ezi-SERVO-HS-PE-86M-B	HSE-86M-B	EzS2-PE-HS86M-B

### · Ezi-SERVOII EtherCAT MINI

Unit Part Number	Motor Model Number	Drive Model Number
Ezi-SERVO-HS-EC-MI-20M-F	HSE-20M-F	EzS2-EC-MI-HS20M-F
Ezi-SERVO-HS-EC-MI-20L-F	HSE-20L-F	EzS2-EC-MI-HS20L-F
Ezi-SERVO-HS-EC-MI-28SM-D	HSE-28SM-D	EzS2-EC-MI-HS28S-D
Ezi-SERVO-HS-EC-MI-28MM-D	HSE-28MM-D	EzS2-EC-MI-HS28M-D
Ezi-SERVO-HS-EC-MI-35MM-D	HSE-35MM-D	EzS2-EC-MI-HS35M-D
Ezi-SERVO-HS-EC-MI-35LM-D	HSE-35LM-D	EzS2-EC-MI-HS35L-D
Ezi-SERVO-HS-EC-MI-42S-A	HSE-42S-A	EzS2-EC-MI-HS42S-A
Ezi-SERVO-HS-EC-MI-42S-B	HSE-42S-B	EzS2-EC-MI-HS42S-B
Ezi-SERVO-HS-EC-MI-42L-A	HSE-42L-A	EzS2-EC-MI-HS42L-A
Ezi-SERVO-HS-EC-MI-42L-B	HSE-42L-B	EzS2-EC-MI-HS42L-B
Ezi-SERVO-HS-EC-MI-56S-A	HSE-56S-A	EzS2-EC-MI-HS56S-A
Ezi-SERVO-HS-EC-MI-56S-B	HSE-56S-B	EzS2-EC-MI-HS56S-B
Ezi-SERVO-HS-EC-MI-56M-A	HSE-56M-A	EzS2-EC-MI-HS56M-A
Ezi-SERVO-HS-EC-MI-56M-B	HSE-56M-B	EzS2-EC-MI-HS56M-B

### · Ezi-SERVOII Plus-E MINI

Unit Part Number	Motor Model Number	Drive Model Number
Ezi-SERVO-HS-PE-MI-20M-F	HSE-20M-F	EzS2-PE-MI-HS20M-F
Ezi-SERVO-HS-PE-MI-20L-F	HSE-20L-F	EzS2-PE-MI-HS20L-F
Ezi-SERVO-HS-PE-MI-28SM-D	HSE-28SM-D	EzS2-PE-MI-HS28S-D
Ezi-SERVO-HS-PE-MI-28MM-D	HSE-28MM-D	EzS2-PE-MI-HS28M-D
Ezi-SERVO-HS-PE-MI-35MM-D	HSE-35MM-D	EzS2-PE-MI-HS35M-D
Ezi-SERVO-HS-PE-MI-35LM-D	HSE-35LM-D	EzS2-PE-MI-HS35L-D
Ezi-SERVO-HS-PE-MI-42S-A	HSE-42S-A	EzS2-PE-MI-HS42S-A
Ezi-SERVO-HS-PE-MI-42S-B	HSE-42S-B	EzS2-PE-MI-HS42S-B
Ezi-SERVO-HS-PE-MI-42L-A	HSE-42L-A	EzS2-PE-MI-HS42L-A
Ezi-SERVO-HS-PE-MI-42L-B	HSE-42L-B	EzS2-PE-MI-HS42L-B
Ezi-SERVO-HS-PE-MI-56S-A	HSE-56S-A	EzS2-PE-MI-HS56S-A
Ezi-SERVO-HS-PE-MI-56S-B	HSE-56S-B	EzS2-PE-MI-HS56S-B
Ezi-SERVO-HS-PE-MI-56M-A	HSE-56M-A	EzS2-PE-MI-HS56M-A
Ezi-SERVO-HS-PE-MI-56M-B	HSE-56M-B	EzS2-PE-MI-HS56M-B

### · Ezi-SERVOII EtherCAT 4X

For motor and drive combinations, please contact local dealer or FASTECH sales department.

Ezi-SERVOII EtherCAT 4X product is basically a 4 axis type product, and you can also select Ezi-SERVOII EtherCAT 3X, a 3 axis type product.

### · Ezi-SERVOII CC-Link

Unit Part Number	Motor Model Number	Drive Model Number
Ezi-SERVO-HS-CL-20M-F	HSE-20M-F	EzS2-CL-HS20M-F
Ezi-SERVO-HS-CL-20L-F	HSE-20L-F	EzS2-CL-HS20L-F
Ezi-SERVO-HS-CL-28SM-D	HSE-28SM-D	EzS2-CL-HS28S-D
Ezi-SERVO-HS-CL-28MM-D	HSE-28MM-D	EzS2-CL-HS28M-D
Ezi-SERVO-HS-CL-35MM-D	HSE-35MM-D	EzS2-CL-HS35M-D
Ezi-SERVO-HS-CL-35LM-D	HSE-35LM-D	EzS2-CL-HS35L-D
Ezi-SERVO-HS-CL-42S-A	HSE-42S-A	EzS2-CL-HS42S-A
Ezi-SERVO-HS-CL-42S-B	HSE-42S-B	EzS2-CL-HS42S-B
Ezi-SERVO-HS-CL-42L-A	HSE-42L-A	EzS2-CL-HS42L-A
Ezi-SERVO-HS-CL-42L-B	HSE-42L-B	EzS2-CL-HS42L-B
Ezi-SERVO-HS-CL-56S-A	HSE-56S-A	EzS2-CL-HS56S-A
Ezi-SERVO-HS-CL-56S-B	HSE-56S-B	EzS2-CL-HS56S-B
Ezi-SERVO-HS-CL-56M-A	HSE-56M-A	EzS2-CL-HS56M-A
Ezi-SERVO-HS-CL-56M-B	HSE-56M-B	EzS2-CL-HS56M-B
Ezi-SERVO-HS-CL-86M-A	HSE-86M-A	EzS2-CL-HS86M-A
Ezi-SERVO-HS-CL-86M-B	HSE-86M-B	EzS2-CL-HS86M-B

## ● Combination of Hollow Shaft Motor and Drive

### · Ezi-SERVO ST

Unit Part Number	Motor Model Number	Drive Model Number
Ezi-SERVO-HS-ST-20M-F	HSE-20M-F	EzS-PD-HS20M-F
Ezi-SERVO-HS-ST-20L-F	HSE-20L-F	EzS-PD-HS20L-F
Ezi-SERVO-HS-ST-28SM-D	HSE-28SM-D	EzS-PD-HS28S-D
Ezi-SERVO-HS-ST-28MM-D	HSE-28MM-D	EzS-PD-HS28M-D
Ezi-SERVO-HS-ST-35MM-D	HSE-35MM-D	EzS-PD-HS35M-D
Ezi-SERVO-HS-ST-35LM-D	HSE-35LM-D	EzS-PD-HS35L-D
Ezi-SERVO-HS-ST-42S-A	HSE-42S-A	EzS-PD-HS42S-A
Ezi-SERVO-HS-ST-42S-B	HSE-42S-B	EzS-PD-HS42S-B
Ezi-SERVO-HS-ST-42L-A	HSE-42L-A	EzS-PD-HS42L-A
Ezi-SERVO-HS-ST-42L-B	HSE-42L-B	EzS-PD-HS42L-B
Ezi-SERVO-HS-ST-56S-A	HSE-56S-A	EzS-PD-HS56S-A
Ezi-SERVO-HS-ST-56S-B	HSE-56S-B	EzS-PD-HS56S-B
Ezi-SERVO-HS-ST-56M-A	HSE-56M-A	EzS-PD-HS56M-A
Ezi-SERVO-HS-ST-56M-B	HSE-56M-B	EzS-PD-HS56M-B
Ezi-SERVO-HS-ST-86M-A	HSE-86M-A	EzS-PD-HS86M-A
Ezi-SERVO-HS-ST-86M-B	HSE-86M-B	EzS-PD-HS86M-B

### · Ezi-SERVO MINI

Unit Part Number	Motor Model Number	Drive Model Number
Ezi-SERVO-HS-MI-20M-F	HSE-20M-F	EzS-PD-MI-HS20M-F
Ezi-SERVO-HS-MI-20L-F	HSE-20L-F	EzS-PD-MI-HS20L-F
Ezi-SERVO-HS-MI-28SM-D	HSE-28SM-D	EzS-PD-MI-HS28S-D
Ezi-SERVO-HS-MI-28MM-D	HSE-28MM-D	EzS-PD-MI-HS28M-D
Ezi-SERVO-HS-MI-35MM-D	HSE-35MM-D	EzS-PD-MI-HS35M-D
Ezi-SERVO-HS-MI-35LM-D	HSE-35LM-D	EzS-PD-MI-HS35L-D
Ezi-SERVO-HS-MI-42S-A	HSE-42S-A	EzS-PD-MI-HS42S-A
Ezi-SERVO-HS-MI-42S-B	HSE-42S-B	EzS-PD-MI-HS42S-B
Ezi-SERVO-HS-MI-42L-A	HSE-42L-A	EzS-PD-MI-HS42L-A
Ezi-SERVO-HS-MI-42L-B	HSE-42L-B	EzS-PD-MI-HS42L-B



## ● Specifications of Hollow Shaft Motor

MODEL		HSE-20 series		HSE-28 series		HSE-35 series			
		UNIT	20M	20L	28S	28M	35M	35L	
DRIVE METHOD		-	Bipolar						
NUMBER OF PHASES		-	2 Phase						
CURRENT per PHASE		A/Phase	0,5	0,5	1,0	1,0	1,0	1,0	
MAXIMUM HOLDING TORQUE		N·m	0,014	0,02	0,053	0,117	0,19	0,36	
ROTOR INERTIA		g·cm <sup>2</sup>	2,45	3,7	6,23	11	17	28	
WEIGHTS		kg	0,080	0,100	0,159	0,212	0,211	0,289	
LENGTH(L)		mm	27,2	38,1	33,35	45	33,6	45,6	
PERMISSIBLE RADIAL LOAD	DIS-TANCE FROM END OF SHAFT	3mm	N	18	18	38	38	22	22
		8mm		30	30	53	53	26	26
		13mm		-	-	-	-	33	33
		18mm		-	-	-	-	46	46
PERMISSIBLE AXIAL LOAD		N	Lower than Motor Unit's Weight						
INSULATION RESISTANCE		MΩ	Min. 100(When measured with a DC500V insulation resistance meter)						
INSULATION CLASS		-	CLASS B(130°C)						
OPERATING TEMPERATURE		°C	0 ~ 55						

MODEL		HSE-42 series		HSE-56 series		HSE-86 series		
		UNIT	42S	42L	56S	56M	86M	
DRIVE METHOD		-	Bipolar					
NUMBER OF PHASES		-	2 Phase					
CURRENT per PHASE		A/Phase	1,0	2,5	2,0	2,5	3,0	
MAXIMUM HOLDING TORQUE		N·m	0,31	0,56	1,2	2,1	4,5	
ROTOR INERTIA		g·cm <sup>2</sup>	30,3	58,1	147,1	281,2	1265,3	
WEIGHTS		kg	0,281	0,420	0,566	0,880	2,226	
LENGTH(L)		mm	34,1	48,1	45	65	76	
PERMISSIBLE RADIAL LOAD	DIS-TANCE FROM END OF SHAFT	3mm	N	22	22	52	52	270
		8mm		26	26	65	65	300
		13mm		33	33	85	85	350
		18mm		46	46	123	123	400
PERMISSIBLE AXIAL LOAD		N	Lower than Motor Unit's Weight					
INSULATION RESISTANCE		MΩ	Min. 100(When measured with a DC500V insulation resistance meter)					
INSULATION CLASS		-	CLASS B(130°C)					
OPERATING TEMPERATURE		°C	0 ~ 55					

# Torque Characteristics of Hollow Shaft Motor

## Applied Drive Series

Ezi-SERVO-HS-EC

Ezi-SERVO-HS-PE

Ezi-SERVO-HS-CL

Ezi-SERVO-HS-ST

### Ezi-SERVO-HS-□-20 series

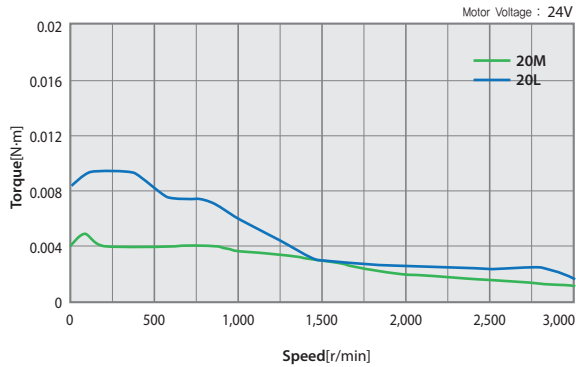

### Ezi-SERVO-HS-□-28 series

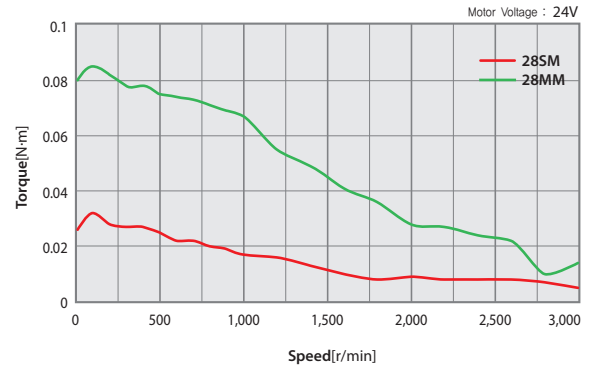

### Ezi-SERVO-HS-□-35 series

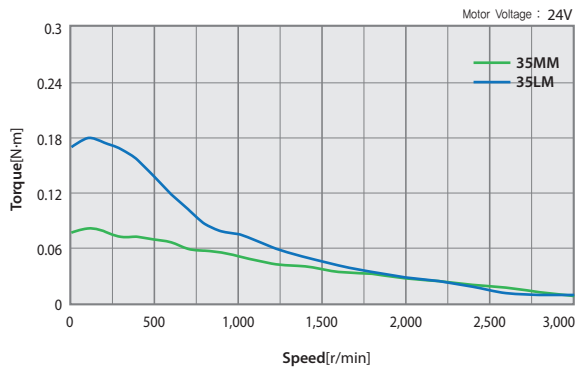

### Ezi-SERVO-HS-□-42 series

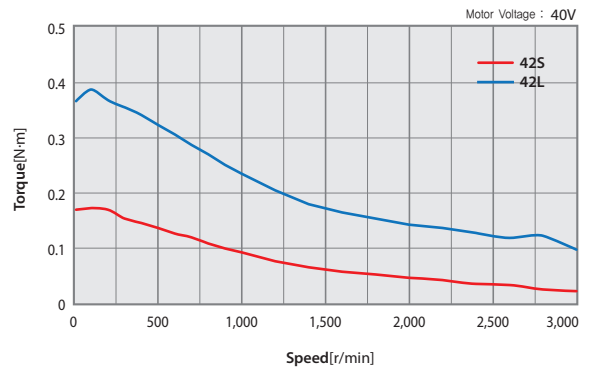

### Ezi-SERVO-HS-□-56 series

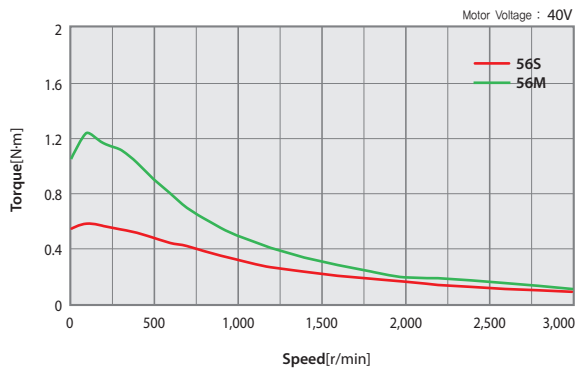

### Ezi-SERVO-HS-□-86 series

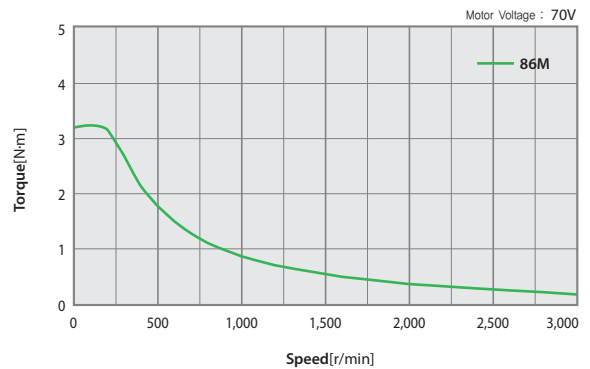

※ □ Drive Series

# Torque Characteristics of Hollow Shaft Motor

## Applied Drive Series

Ezi-SERVO-HS-EC-MI

Ezi-SERVO-HS-EC-4X

Ezi-SERVO-HS-PE-MI

Ezi-SERVO-HS-MI

### Ezi-SERVO-HS-□-20 series

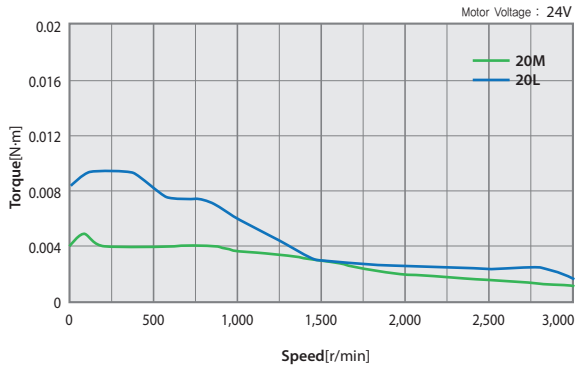

### Ezi-SERVO-HS-□-28 series

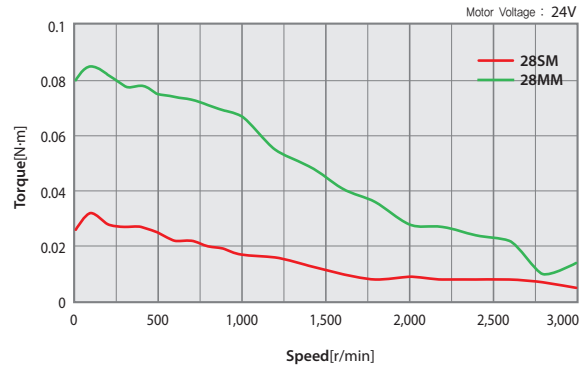

### Ezi-SERVO-HS-□-35 series

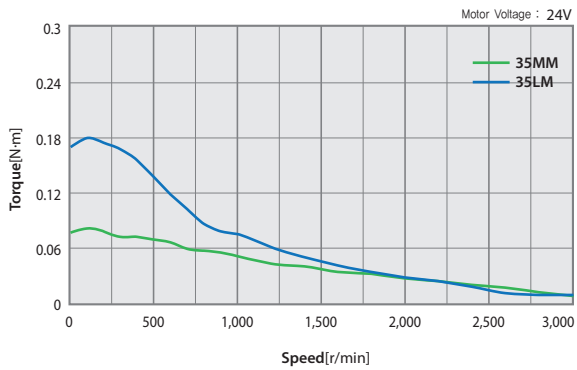

### Ezi-SERVO-HS-□-42 series

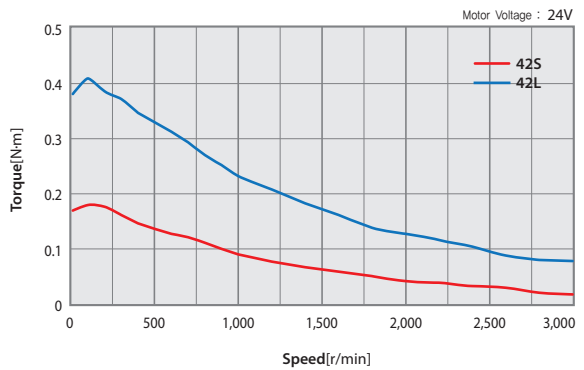

### Ezi-SERVO-HS-□-56 series

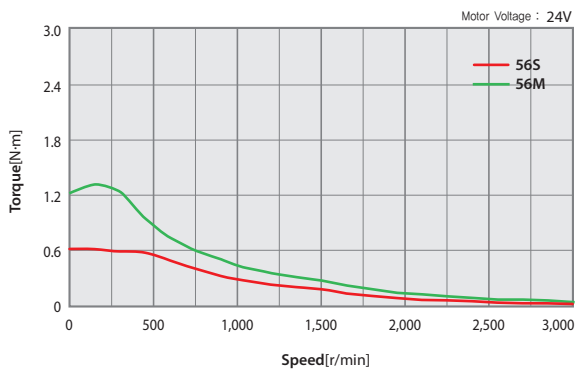

- ※ □ Drive Series
- ※ Ezi-SERVO-HS-MI doesn't have 56 series.

## ● Dimensions of Hollow Shaft Motor [mm]

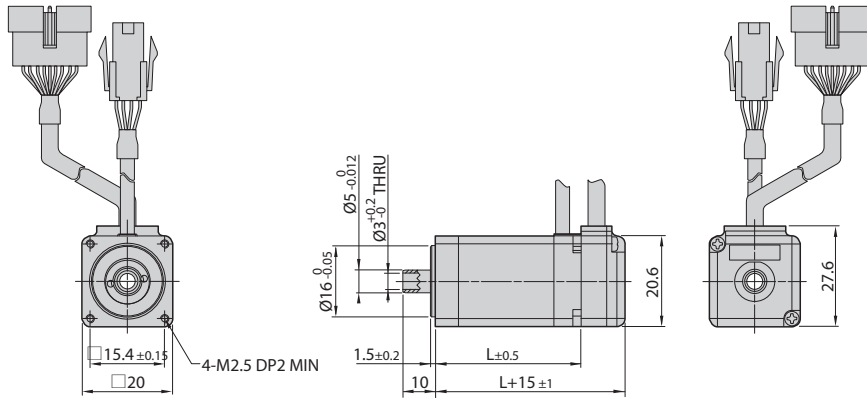

### 20mm

Model Name	Length(L)
HSE-20M	27,2
HSE-20L	39,7

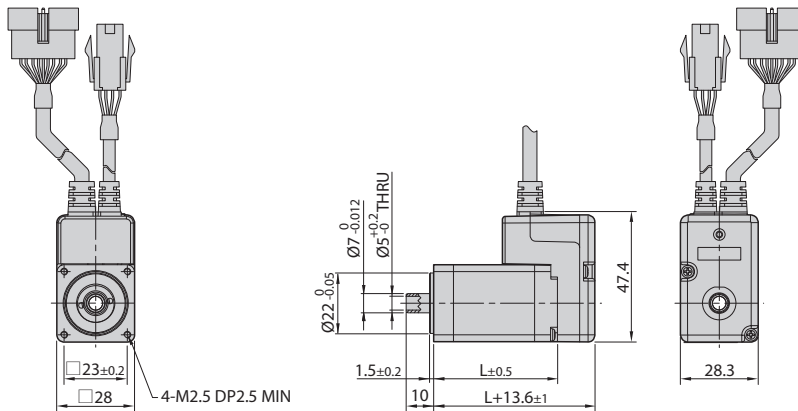

### 28mm

Model Name	Length(L)
HSE-28SM	33,35
HSE-28MM	45

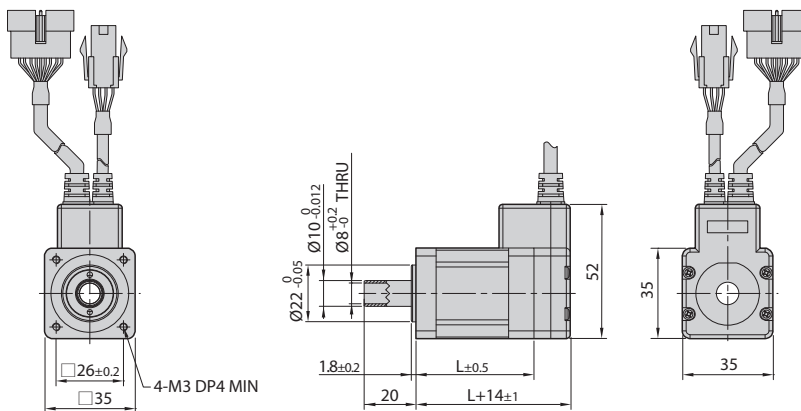

### 35mm

Model Name	Length(L)
HSE-35MM	33,6
HSE-35LM	45,6

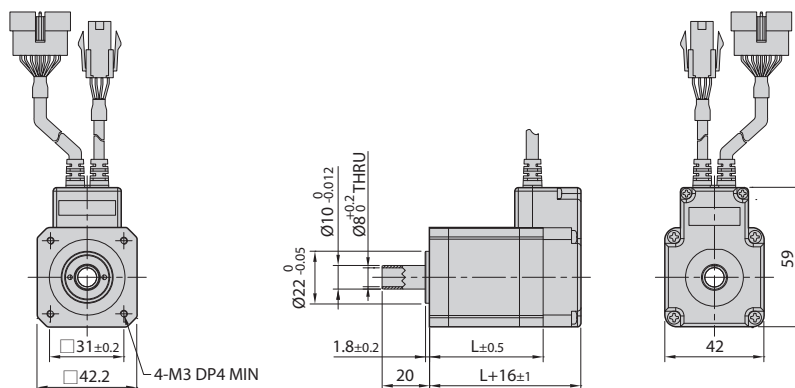

### 42mm

Model Name	Length(L)
HSE-42S	34,1
HSE-42L	48,1

## ● Dimensions of Hollow Shaft Motor [mm]

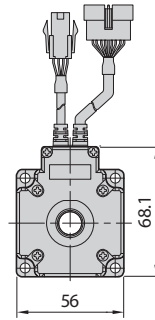
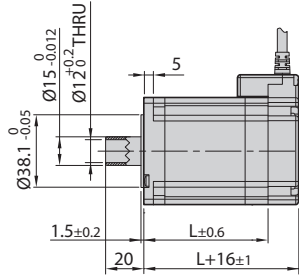
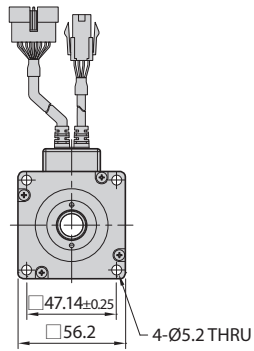

### 56mm

Model Name	Length(L)
HSE-56S	45
HSE-56M	65

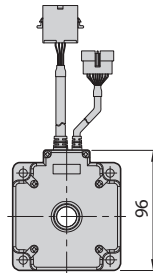
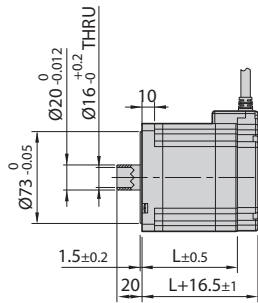
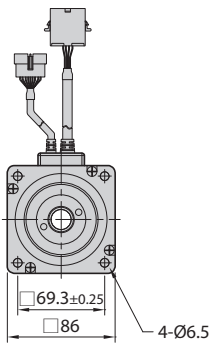

### 86mm

Model Name	Length(L)
HSE-86M	76

# ● System Configuration [EtherCAT (Ezi-SERVO II EtherCAT)]

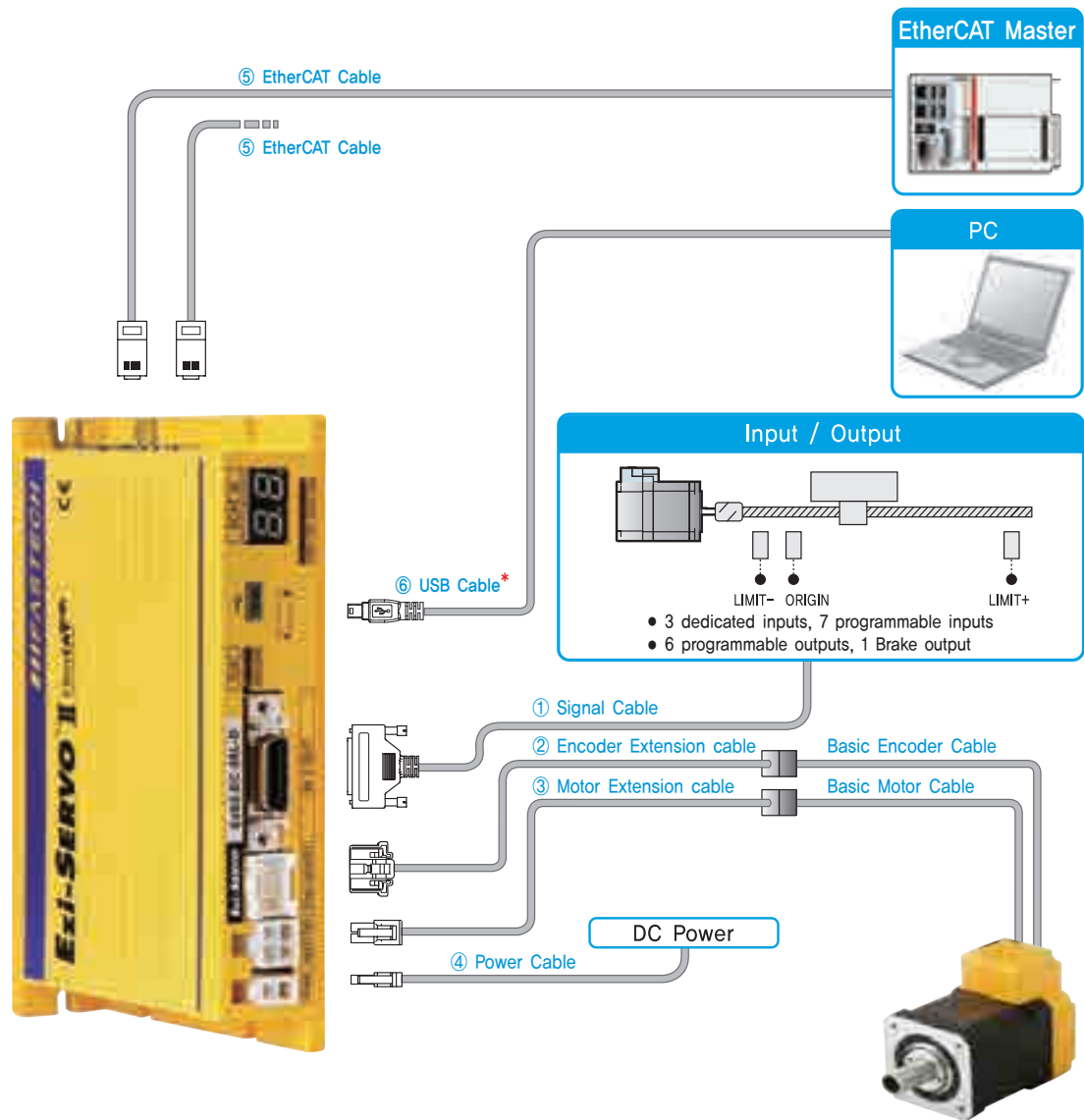

FASTECH Ezi-SERVO HS

Cable Type	Max. Length	Remarks
① Signal Cable	20m	Options (Sold separately)
② Encoder Extension Cable	20m	
③ Motor Extension Cable	20m	
④ Power Cable	2m	
⑤ EtherCAT Cable	100m	Basic cables are attached to motors.
Basic Encoder Cable	0,3m (Basic length)	
Basic Motor Cable	0,3m (Basic length)	
USB Cable	5m	* USB cables are not provided by FASTECH. We recommend using a standard USB cable (USB 2,0 Mini Type B).

- Ezi-SERVO II EtherCAT is stepping motor control system using EtherCAT, high speed ethernet (100Mbps Full-Duplex) based fieldbus. Ezi-SERVO II EtherCAT is EtherCAT slave module which supports CAN application layer over EtherCAT (CoE). It employs CiA 402 Drive Profile and supports Profile Position Mode, Homing Mode, Cyclic Synchronous Position Mode.
- Please refer to Ezi-SERVO II EtherCAT catalog for more detailed information about Ezi-SERVO II EtherCAT drive.

## ● System Configuration [EtherCAT (Ezi-SERVO II EtherCAT 86mm)]

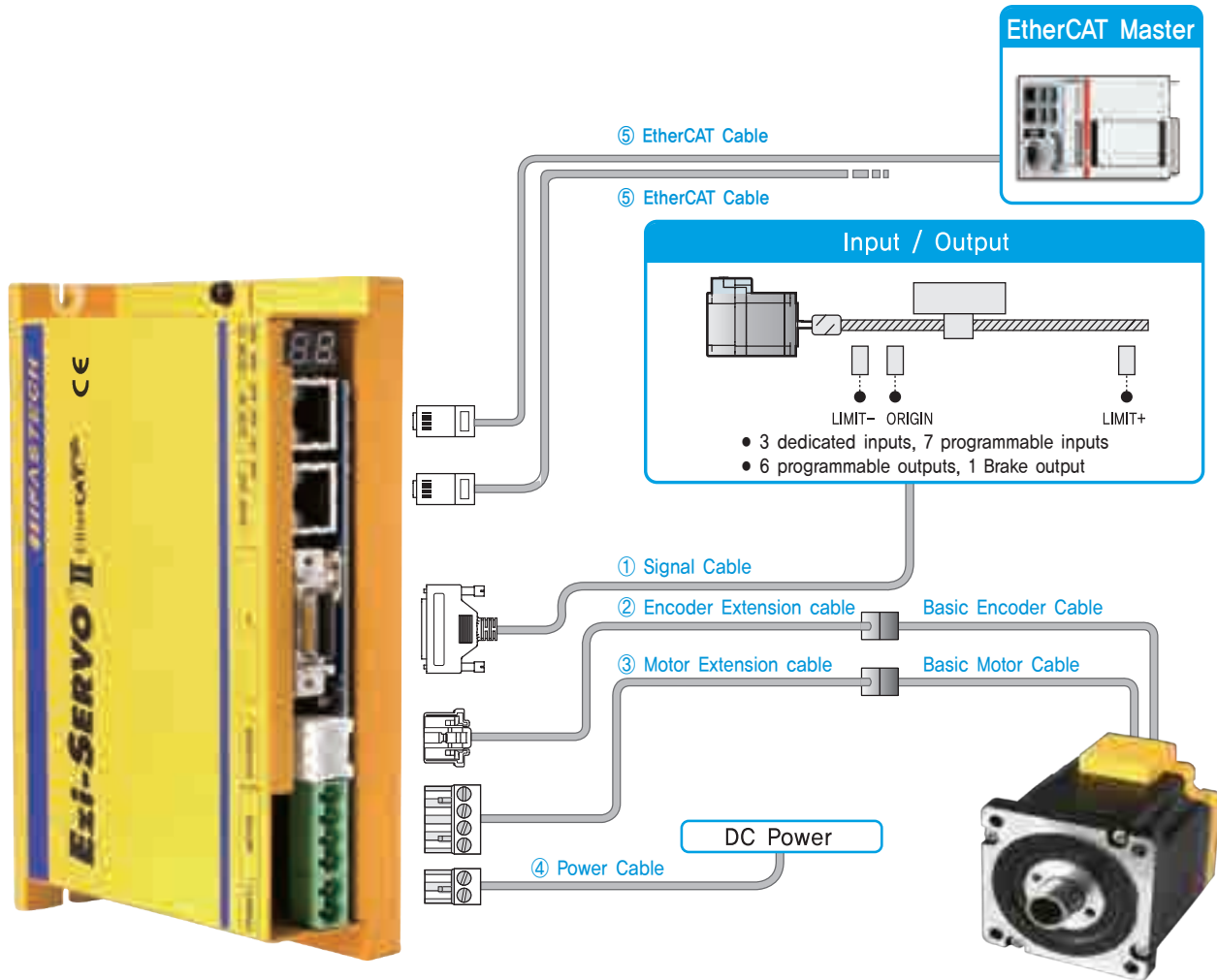

FASTECH Ezi-SERVO HS

Cable Type	Max. Length	Remarks
① Signal Cable	20m	Options (Sold separately)
② Encoder Extension Cable	20m	
③ Motor Extension Cable	20m	
④ Power Cable	2m	
⑤ EtherCAT Cable	100m	Basic cables are attached to motors.
Basic Encoder Cable	0,3m (Basic length)	
Basic Motor Cable	0,3m (Basic length)	

- Ezi-SERVO II EtherCAT is stepping motor control system using EtherCAT, high speed ethernet (100Mbps Full-Duplex) based fieldbus. Ezi-SERVO II EtherCAT is EtherCAT slave module which supports CAN application layer over EtherCAT (CoE). It employs CiA 402 Drive Profile and supports Profile Position Mode, Homing Mode, Cyclic Synchronous Position Mode.

- Please refer to Ezi-SERVO II EtherCAT catalog for more detailed information about Ezi-SERVO II EtherCAT drive.

## ● System Configuration [EtherCAT Mini Type (Ezi-SERVO II EtherCAT MINI)]

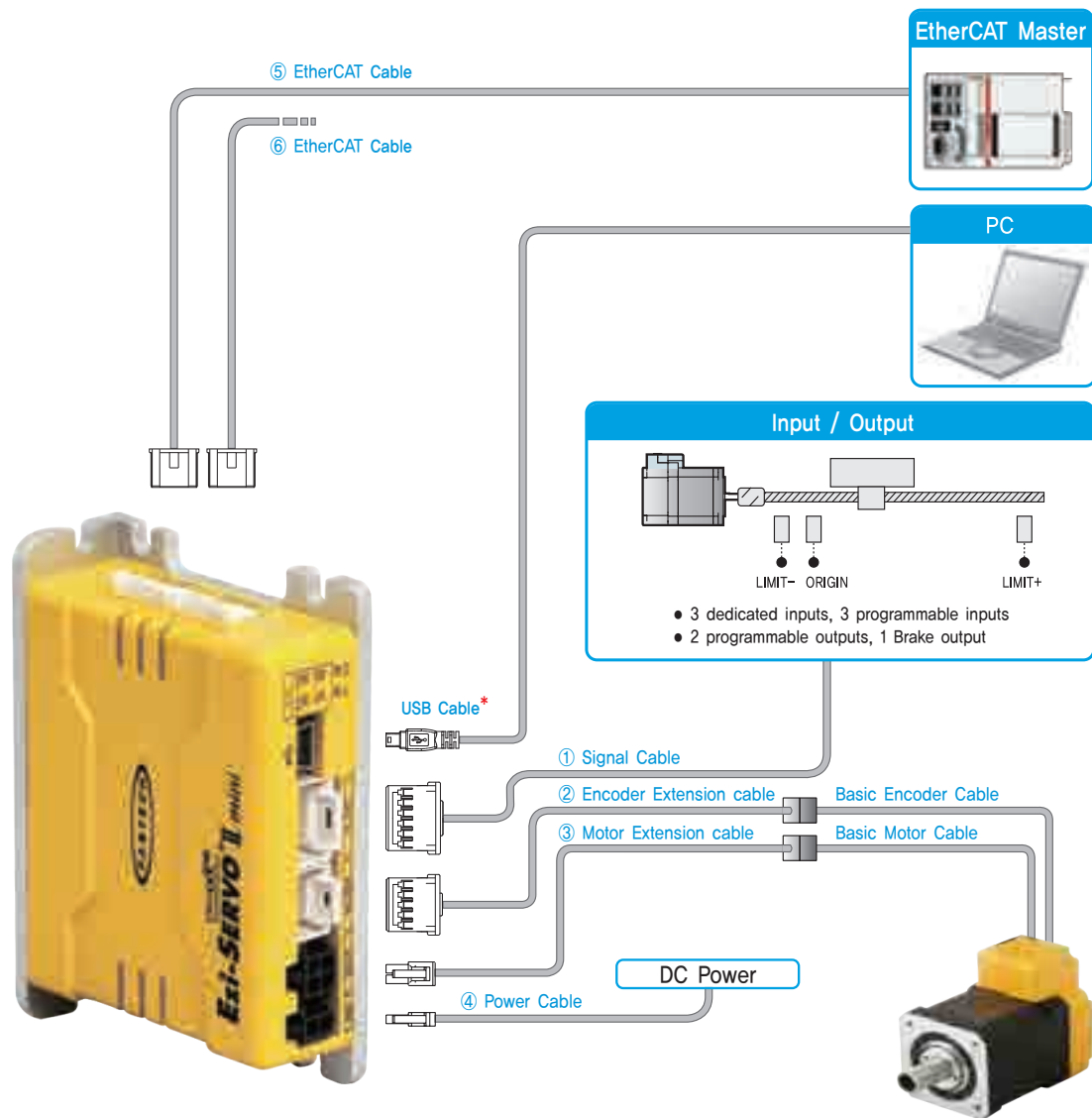

FASTECH Ezi-SERVO HS

Cable Type	Max. Length	Remarks
① Signal Cable	20m	Options (Sold separately)
② Encoder Extension Cable	20m	
③ Motor Extension Cable	20m	
④ Power Cable	2m	
⑤/⑥ EtherCAT Cable	100m	Basic cables are attached to motors.
Basic Encoder Cable	0.3m (Basic length)	
Basic Motor Cable	0.3m (Basic length)	
USB Cable	5m	* USB cables are not provided by FASTECH. We recommend using a standard USB cable (USB 2.0 Mini Type B).

- Ezi-SERVO II EtherCAT MINI is stepping motor control system using EtherCAT, high speed ethernet (100Mbps Full-Duplex) based fieldbus. Ezi-SERVO II EtherCAT MINI is EtherCAT slave module which supports CAN application layer over EtherCAT (CoE). It employs CiA 402 Drive Profile and supports Profile Position Mode, Homing Mode, Cyclic Synchronous Position Mode.

- Please refer to Ezi-SERVO II EtherCAT MINI catalog for more detailed information about Ezi-SERVO II EtherCAT MINI drive.



## ● System Configuration [EtherCAT 4X (Ezi-SERVO II EtherCAT 4X)]

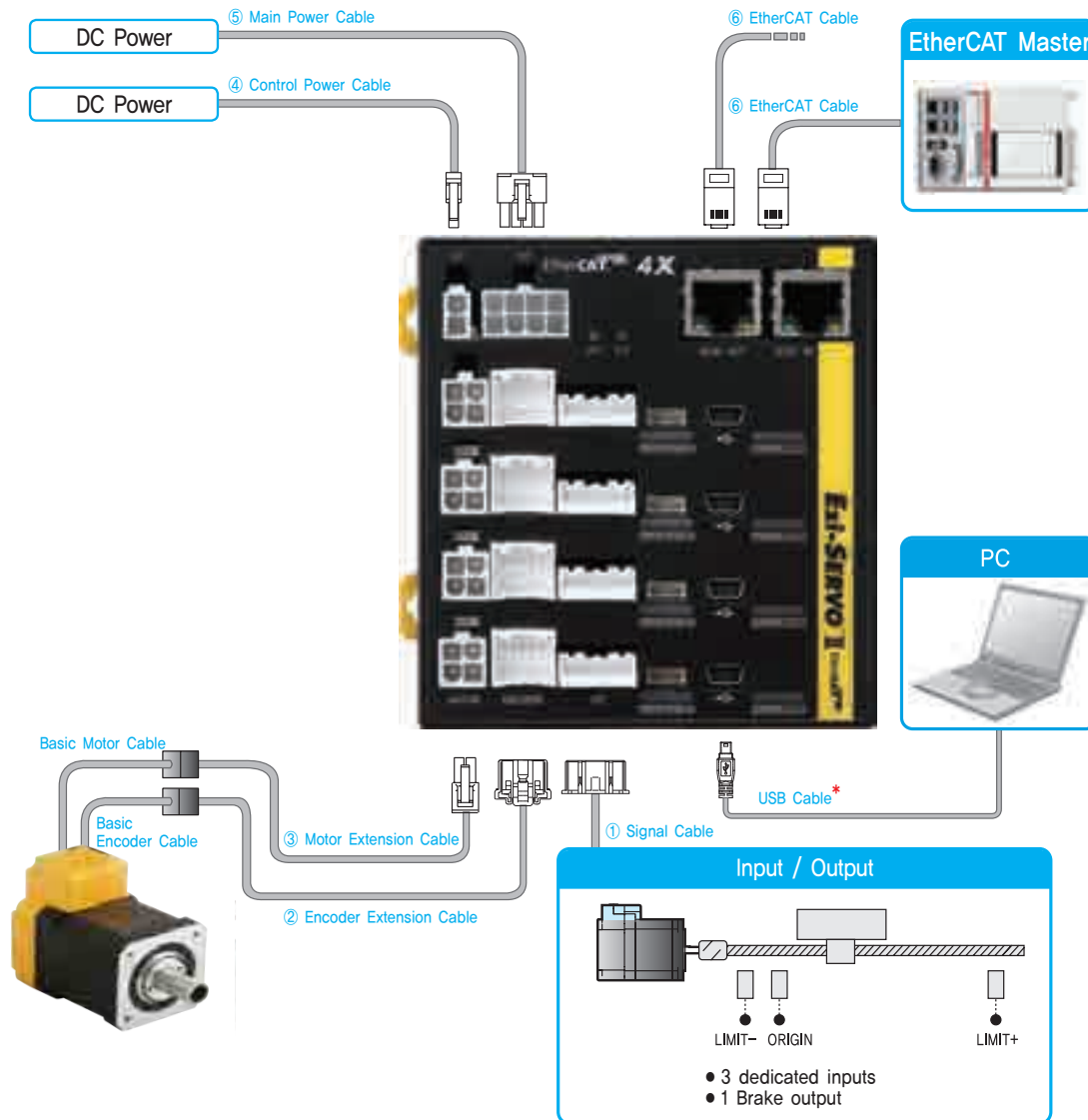

Cable Type	Max. Length	Remarks
① Signal Cable	20m	Options (Sold separately)
② Encoder Cable	20m	
③ Motor Extension Cable	20m	
④ Control Power Cable	2m	
⑤ Main Power Cable	2m	
⑥ EtherCAT Cable	100m	
Basic Encoder Cable	0,3m (Basic length)	Basic cables are attached to motors.
Basic Motor Cable	0,3m (Basic length)	
USB Cable	5m	* USB cables are not provided by FASTECH. We recommend using a standard USB cable (USB 2,0 Mini Type B).

- Ezi-SERVO II EtherCAT 4X is stepping motor control system using EtherCAT, high speed ethernet (100Mbps Full-Duplex) based fieldbus, Ezi-SERVO II EtherCAT 4X is EtherCAT slave module which supports CAN application layer over EtherCAT (CoE). It employs CiA 402 Drive Profile and supports Profile Position Mode, Homing Mode, Cyclic Synchronous Position Mode.
- Please refer to Ezi-SERVO II EtherCAT 4X catalog for more detailed information about Ezi-SERVO II EtherCAT 4X drive.

## ● System Configuration [Ethernet (Ezi-SERVO II Plus-E)]

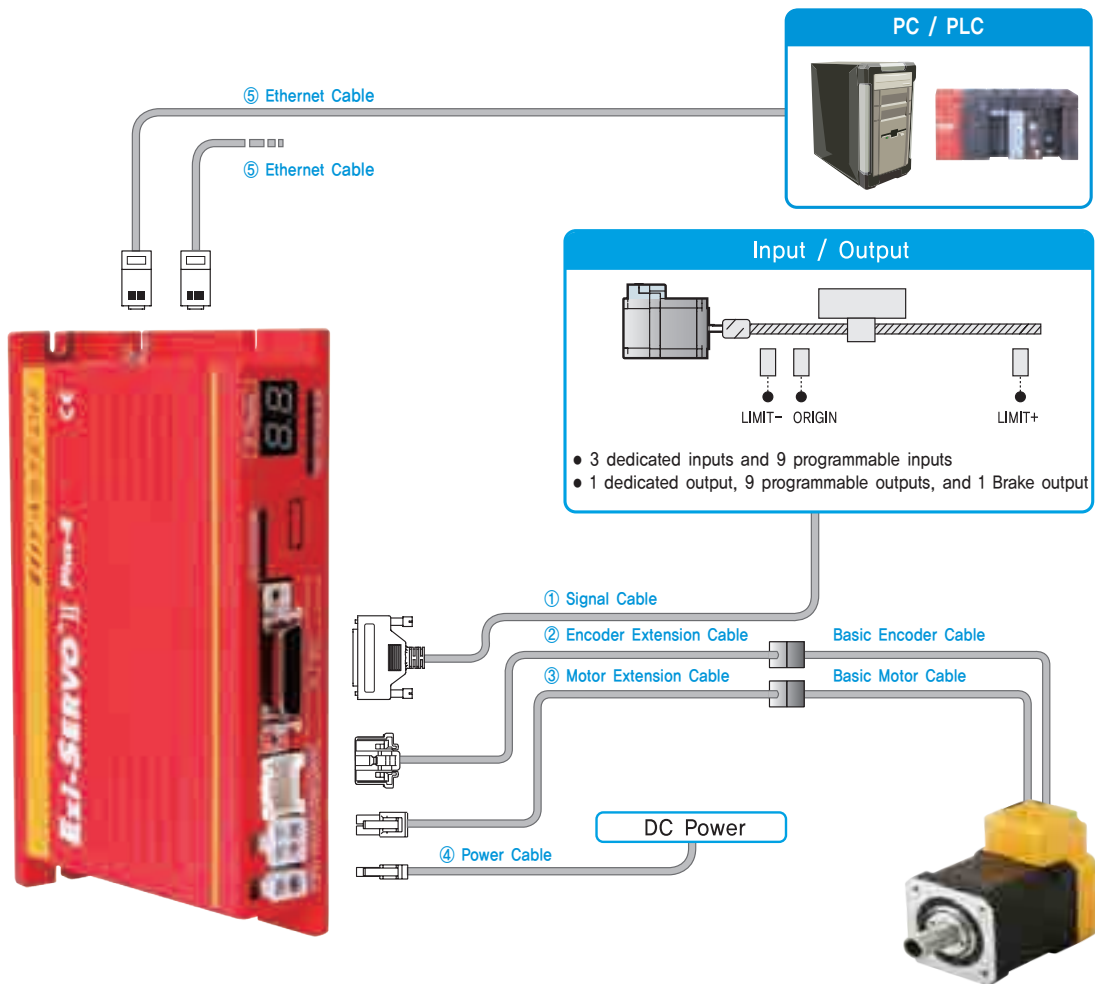

FASTECH Ezi-SERVO HS

Cable Type	Max. Length	Remarks
① Signal Cable	20m	Options (Sold separately)
② Encoder Extension Cable	20m	
③ Motor Extension Cable	20m	
④ Power Cable	2m	
⑤ Ethernet Cable	100m	Basic cables are attached to motors.
Basic Encoder Cable	0,3m (Basic length)	
Basic Motor Cable	0,3m (Basic length)	

- Ezi-SERVO II Plus-E is a stepping motor control system that can drive up to 254 axis through Ethernet. It has a built-in Ethernet switch, so the system can be built in a daisy chain method. All motions can be controlled by Ethernet communication, and the conditions related to motions are stored in ROM as parameters. In addition, Ezi-SERVO II Plus-E provides a motion library(API) for programming in Windows 7/8/10.

- Please refer to Ezi-SERVO II Plus-E catalog for more detailed information about Ezi-SERVO II Plus-E drive.

## ● System Configuration [Ethernet (Ezi-SERVO II Plus-E 86mm)]

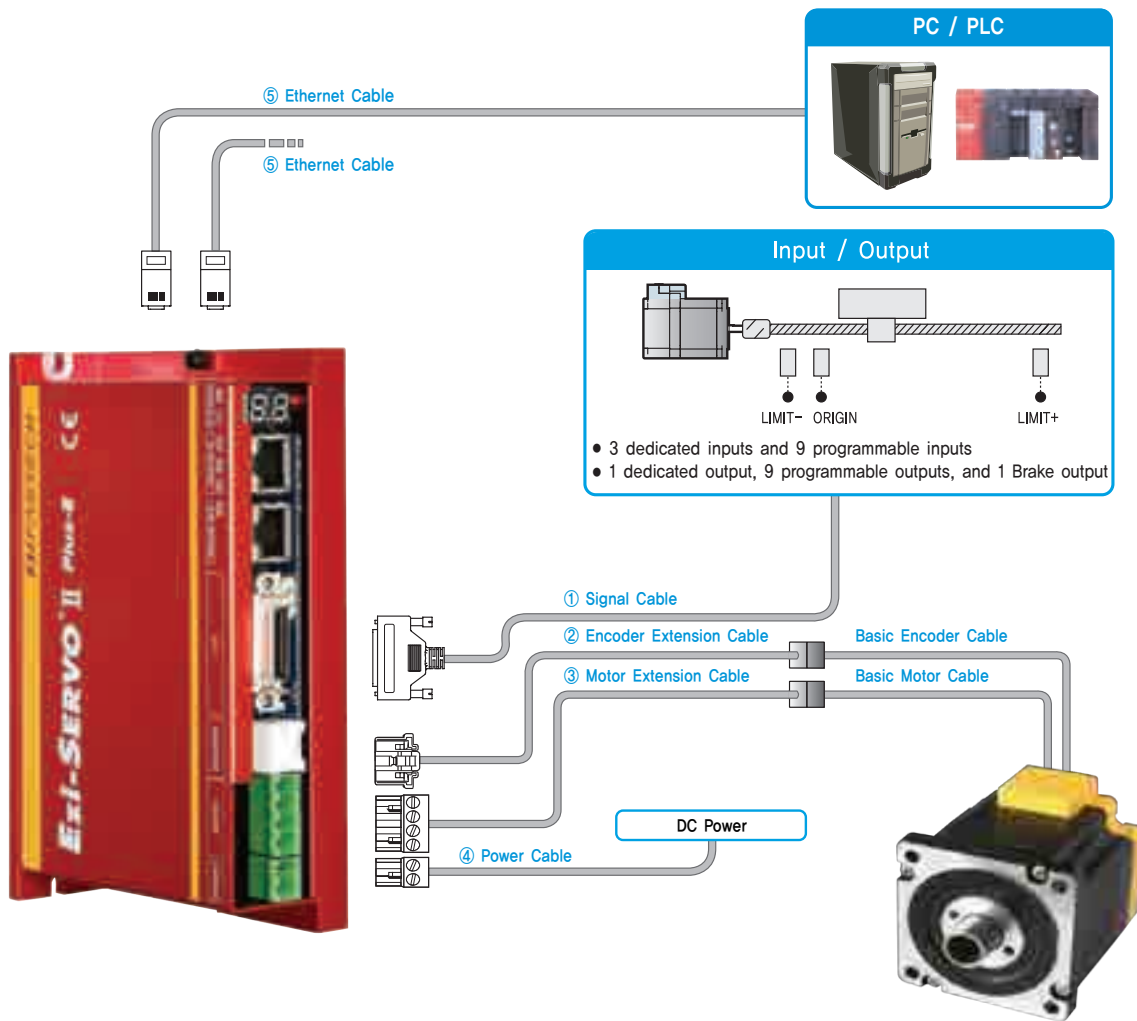

Cable Type	Max. Length	Remarks
① Signal Cable	20m	Options (Sold separately)
② Encoder Extension Cable	20m	
③ Motor Extension Cable	20m	
④ Power Cable	2m	
⑤ Ethernet Cable	100m	Basic cables are attached to motors.
Basic Encoder Cable	0,3m (Basic length)	
Basic Motor Cable	0,3m (Basic length)	

● Ezi-SERVO II Plus-E is a stepping motor control system that can drive up to 254 axis through Ethernet. It has a built-in Ethernet switch, so the system can be built in a daisy chain method. All motions can be controlled by Ethernet communication, and the conditions related to motions are stored in ROM as parameters. In addition, Ezi-SERVO II Plus-E provides a motion library(API) for programming in Windows 7/8/10.

● Please refer to Ezi-SERVO II Plus-E catalog for more detailed information about Ezi-SERVO II Plus-E drive.

## ● System Configuration [Ethernet Mini Type (Ezi-SERVO II Plus-E MINI)]

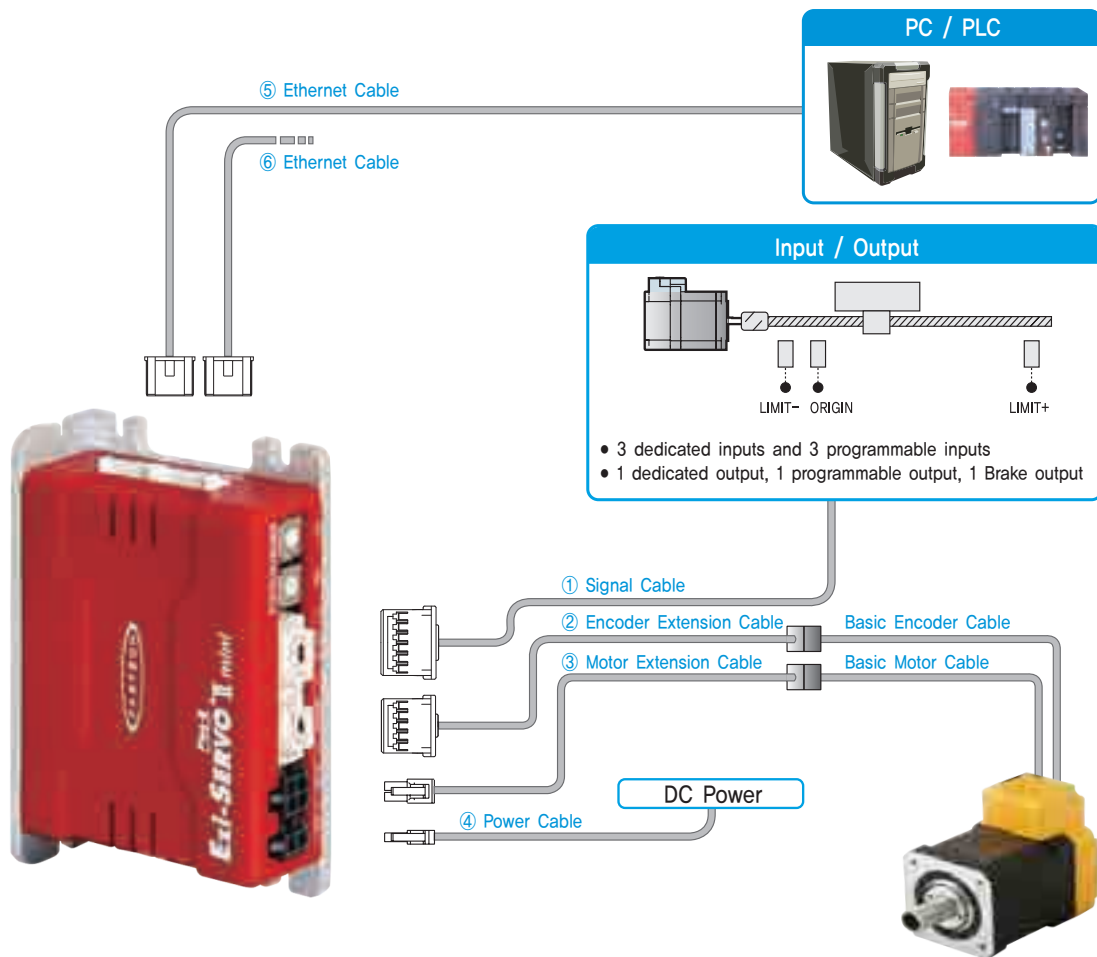

FASTECH Ezi-SERVO HS

Cable Type	Max. Length	Remarks
① Signal Cable	20m	Options (Sold separately)
② Encoder Extension Cable	20m	
③ Motor Extension Cable	20m	
④ Power Cable	2m	
⑤/⑥ Ethernet Cable	100m	Basic cables are attached to motors.
Basic Encoder Cable	0.3m (Basic length)	
Basic Motor Cable	0.3m (Basic length)	

- Ezi-SERVO II Plus-E MINI is a stepping motor control system that can drive up to 254 axis through Ethernet. It has a built-in Ethernet switch, so the system can be built in a daisy chain method. All motions can be controlled by Ethernet communication, and the conditions related to motions are stored in ROM as parameters. In addition, Ezi-SERVO II Plus-E MINI provides a motion library(API) for programming in Windows 7/8/10.

- Please refer to Ezi-SERVO II Plus-E MINI catalog for more detailed information about Ezi-SERVO II Plus-E MINI drive.

## ● System Configuration [CC-Link (Ezi-SERVO II CC-Link)]

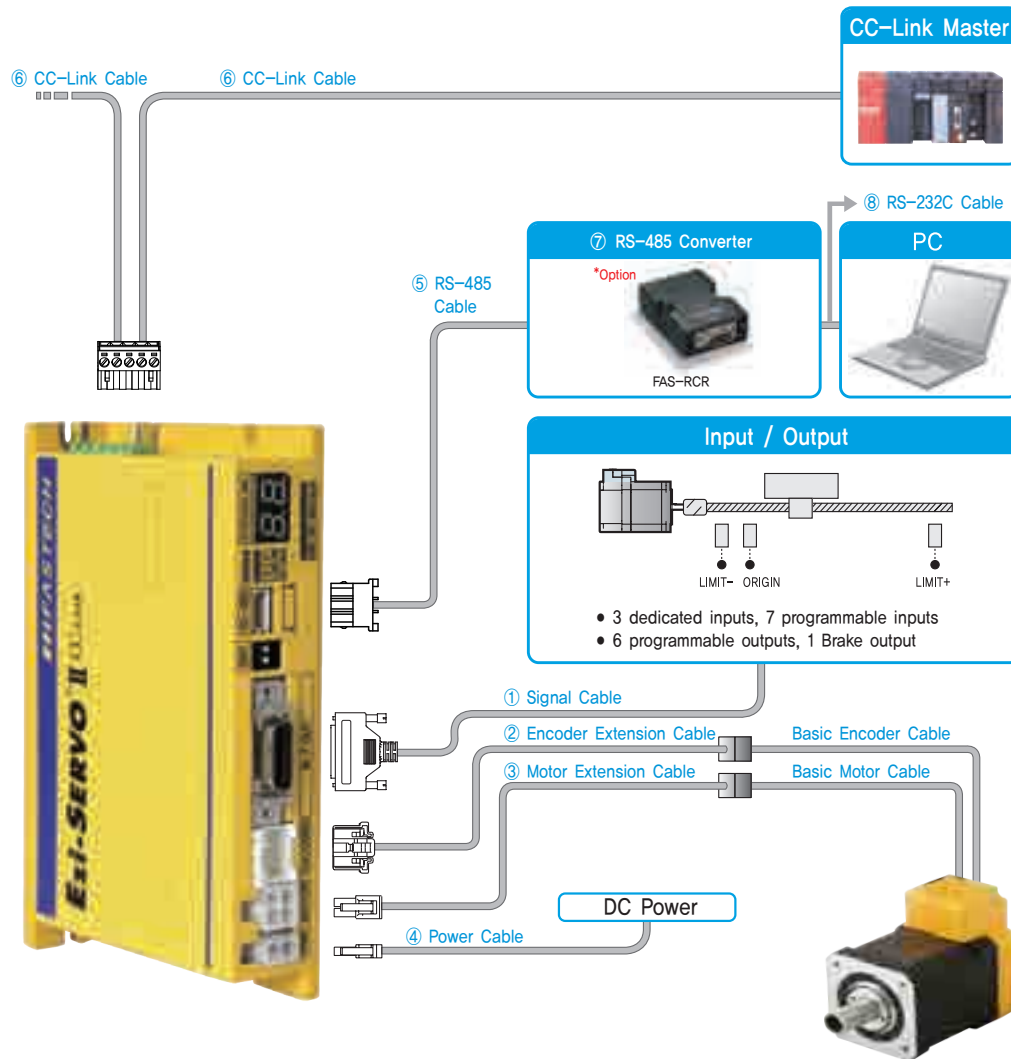

Cable Type	Max. Length	Remarks
① Signal Cable	20m	Options (Sold separately)
② Encoder Extension Cable	20m	
③ Motor Extension Cable	20m	
④ Power Cable	2m	
⑤ RS-485 Cable	2m	Basic cables are attached to motors.
⑥ CC-Link Cable	100m	
Basic Encoder Cable	0,3m (Basic length)	
Basic Motor Cable	0,3m (Basic length)	

- Ezi-SERVO II CC-Link is a remote device module that supports high speed Fieldbus(Max, 10Mbps) network, It occupies 1 to 3 station in CC-Link, enabling multi-function control, and processes motion and monitoring functions with device commands.
- Please refer to Ezi-SERVO II CC-Link catalog for more detailed information about Ezi-SERVO II CC-Link drive.

## ● System Configuration [CC-Link (Ezi-SERVO II CC-Link 86mm)]

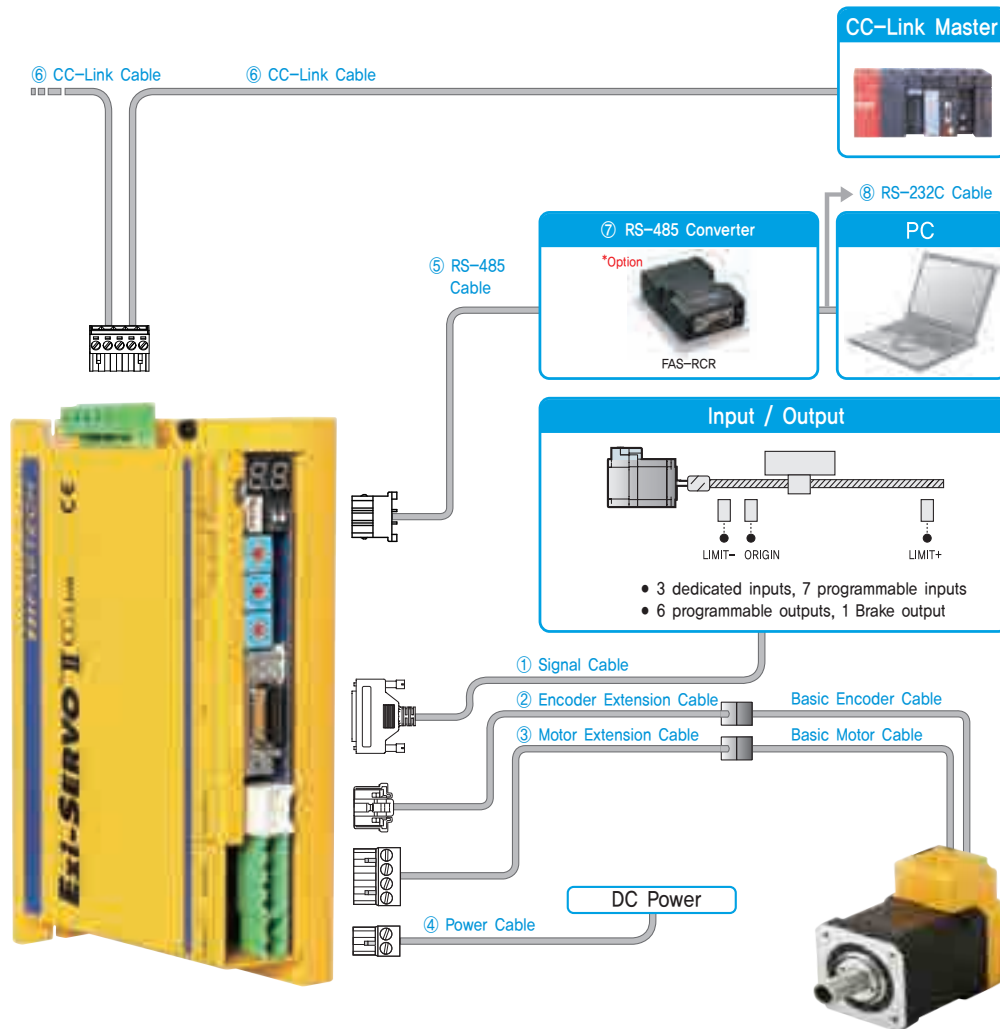

FASTECH Ezi-SERVO HS

Cable Type	Max. Length	Remarks
① Signal Cable	20m	Options (Sold separately)
② Encoder Extension Cable	20m	
③ Motor Extension Cable	20m	
④ Power Cable	2m	
⑤ RS-485 Cable	2m	
⑥ CC-Link Cable	100m	Basic cables are attached to motors.
Basic Encoder Cable	0.3m (Basic length)	
Basic Motor Cable	0.3m (Basic length)	

- Ezi-SERVO II CC-Link is a remote device module that supports high speed Fieldbus(Max. 10Mbps) network. It occupies 1 to 3 station in CC-Link, enabling multi-function control, and processes motion and monitoring functions with device commands.
- Please refer to Ezi-SERVO II CC-Link catalog for more detailed information about Ezi-SERVO II CC-Link drive.

## ● System Configuration [Pulse Input Type (Ezi-SERVO ST)]

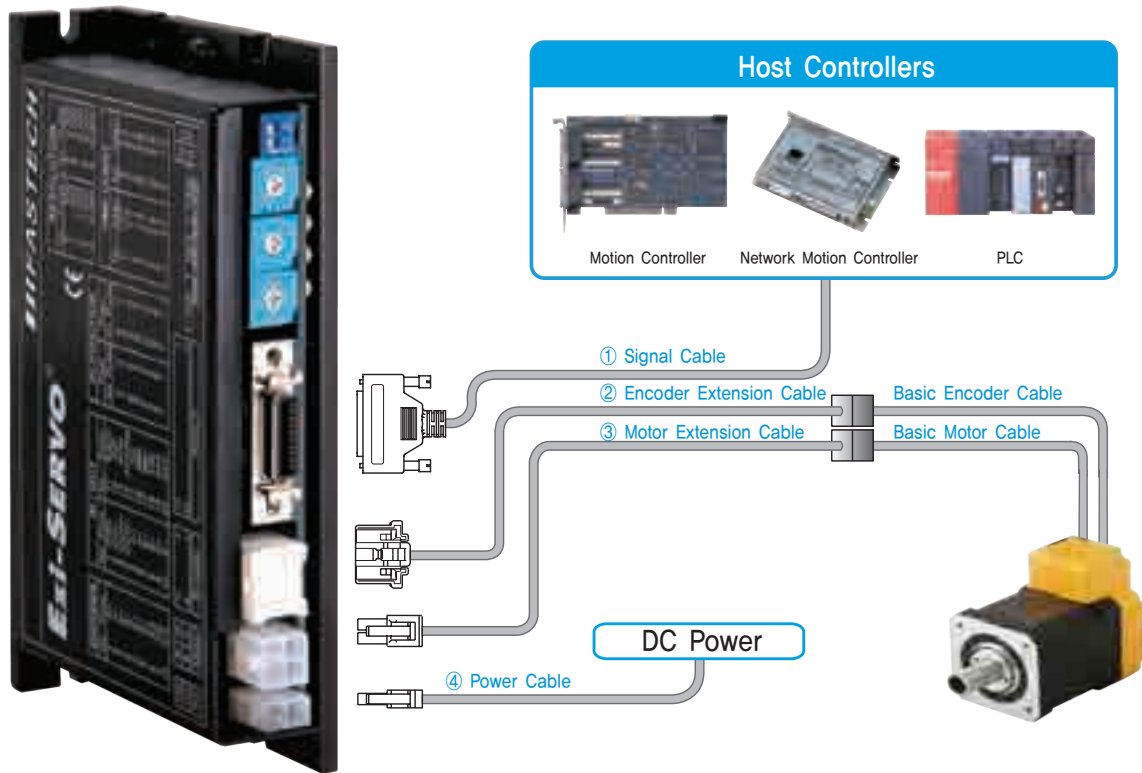

Cable Type	Max. Length	Remarks
① Signal Cable	20m	Options (Sold separately)
② Encoder Extension Cable	20m	
③ Motor Extension Cable	20m	
④ Power Cable	2m	
Basic Encoder Cable	0,3m (Basic length)	Basic cables are attached to motors.
Basic Motor Cable	0,3m (Basic length)	

- Ezi-SERVO ST is a pulse input type drive.
- Please refer to Ezi-SERVO ST catalog for more detailed information about Ezi-SERVO ST drive.

## ● System Configuration [Pulse Input Type (Ezi-SERVO ST 86mm)]

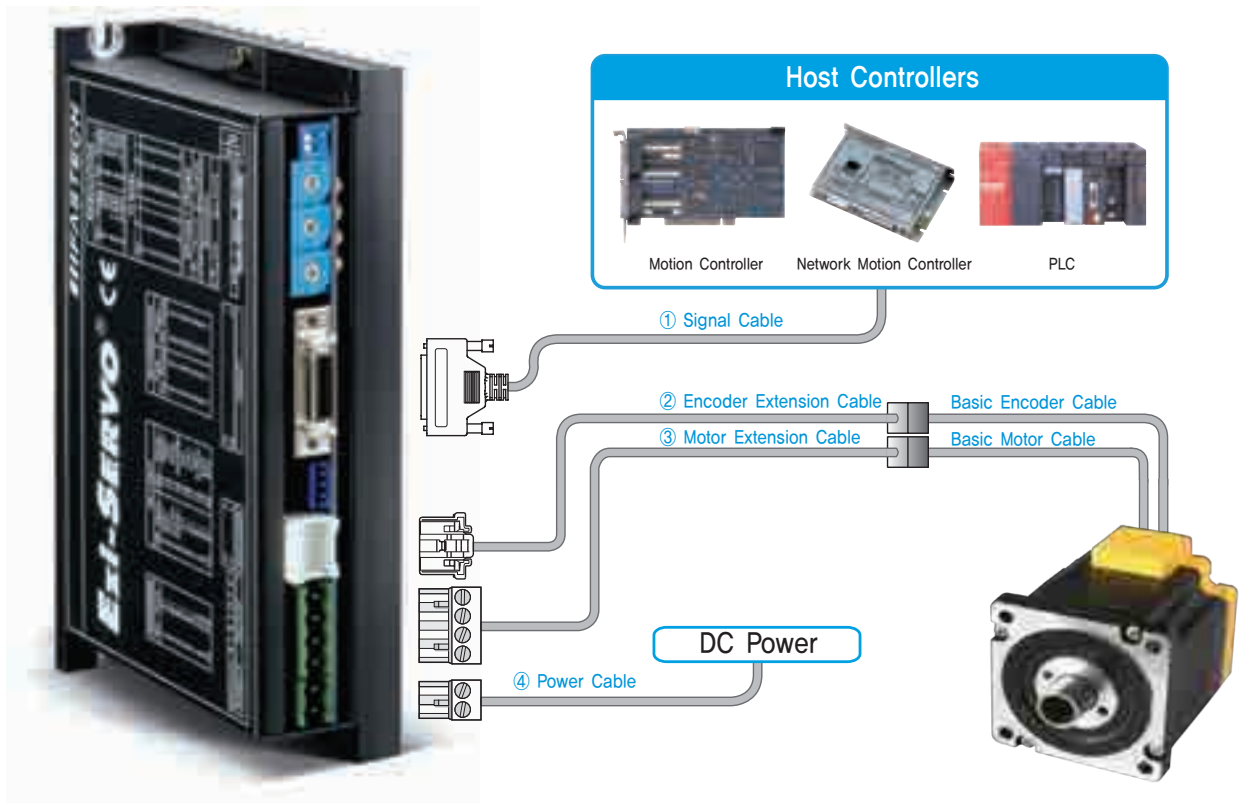

Cable Type	Max. Length	Remarks
① Signal Cable	20m	Options (Sold separately)
② Encoder Extension Cable	20m	
③ Motor Extension Cable	20m	
④ Power Cable	2m	Basic cables are attached to motors.
Basic Encoder Cable	0,3m (Basic length)	
Basic Motor Cable	0,3m (Basic length)	

- Ezi-SERVO ST is a pulse input type drive.
- Please refer to Ezi-SERVO ST catalog for more detailed information about Ezi-SERVO ST drive.



## ● System Configuration [Pulse Input Mini Type (Ezi-SERVO MINI)]

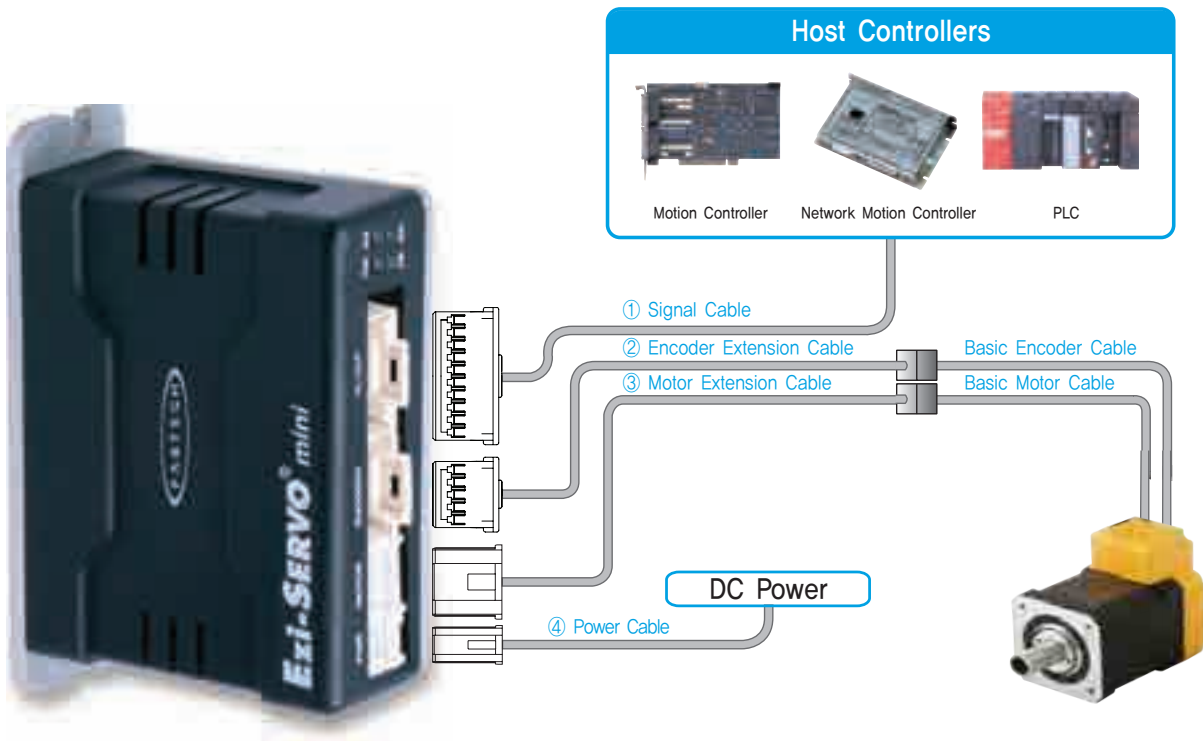

Cable Type	Max. Length	Remarks
① Signal Cable	20m	Options (Sold separately)
② Encoder Extension Cable	20m	
③ Motor Extension Cable	20m	
④ Power Cable	2m	Basic cables are attached to motors.
Basic Encoder Cable	0,3m (Basic length)	
Basic Motor Cable	0,3m (Basic length)	

- Ezi-SERVO MINI is a pulse input type drive.
- Please refer to Ezi-SERVO MINI catalog for more detailed information about Ezi-SERVO ST drive.

# MEMO

**MEMO**



*Fast, Accurate, Smooth Motion*

**FASTECH Co., Ltd.**

Rm#1202, 401-dong, Bucheon Techno-Park,  
655, Pyeongcheon-ro, Bucheon-si Gyeonggi-do,  
Republic of Korea (Postal Code: 14502)  
TEL : +82-32-234-6317 FAX : +82-32-234-6302  
E-mail : [sales@fastech-motions.com](mailto:sales@fastech-motions.com)  
Homepage : [www.fastech-motions.com](http://www.fastech-motions.com)