

Ezi-SERVO[®] II

Closed Loop Stepping System

- CiA402 Drive Profile Support
- Closed-Loop Stepping system
- Tuning Not Required / No Hunting
- Space Saving / Reduced Wiring by Compact Drive
- High Resolution / High Response

EtherCAT[®]
MINI



CE

FASTECH

Fast, Accurate, Smooth Motion

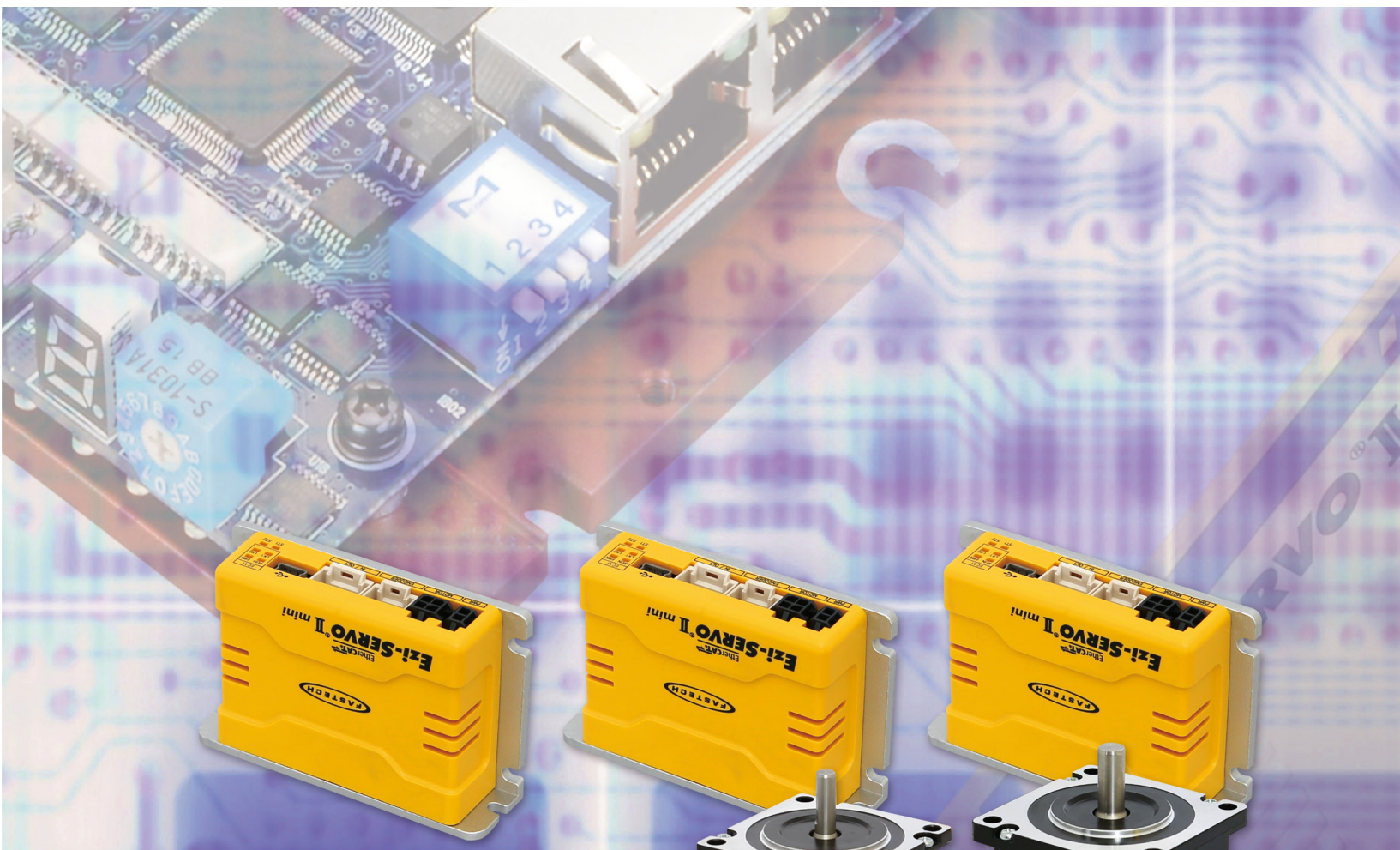

Fast, Accurate, Smooth Motion

Ezi-SERVO[®] II
Closed Loop Stepping System

EtherCAT[®]
MINI



1 EtherCAT Based Motion Control

Ezi-SERVOII EtherCAT MINI is stepping motor control system using EtherCAT, high speed ethernet (100Mbps Full-Duplex) based fieldbus. Ezi-SERVOII EtherCAT MINI is EtherCAT slave module which supports CAN application layer over EtherCAT (CoE). It employs CiA 402 Drive Profile and supports Profile Position Mode, Homing Mode, Cyclic Synchronous Position Mode.

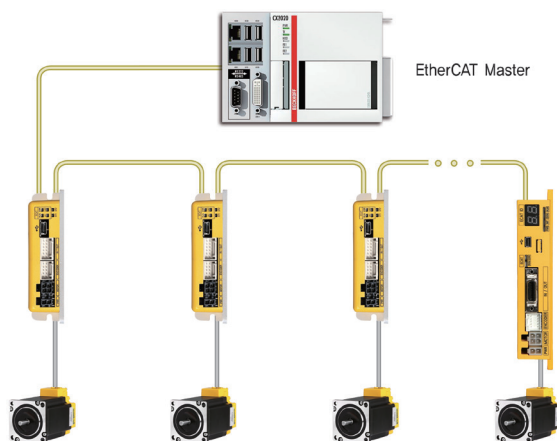

2 Closed-Loop System

Ezi-SERVOII is an innovative Closed-Loop System that utilizes a high-resolution motor mounted encoder constantly to monitor the current position. The encoder feedback allows the Ezi-SERVOII to update the current position every 50µs. It allows the Ezi-SERVOII drive to compensate for the loss of position, ensuring accurate positioning. For example, due to a sudden load change, a conventional stepping motor and drive could lose a step but Ezi-SERVOII automatically correct the position by encoder feedback.

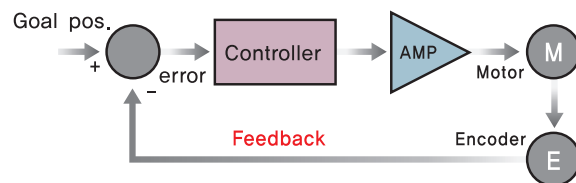

3 Tuning Not Required

To ensure machine performance, conventional servo systems require the adjustment of its servo's gains as an initial crucial step. Even systems that employ auto-tuning require manual tuning after the system is installed. Ezi-SERVOII employs the best characteristics of the stepping motor to eliminate the need of tedious gain tuning required for conventional closed-loop servo systems. Ezi-SERVOII is especially well suited for low-rigidity loads (e.g., a belt and pulley system) that sometimes require conventional servo systems to use the additional bulky and expensive gearbox.

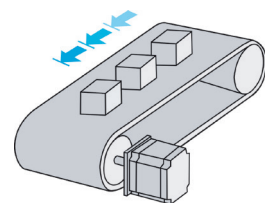

4 Low Heat Generation / Energy Savings

(Motor Current Control according to load)

Ezi-SERVOII automatically controls motor current according to load.

Ezi-SERVOII reduces motor current when motor load is low and increases motor current when load is high. By optimizing the motor current, motor heat can be minimized and energy can be saved.

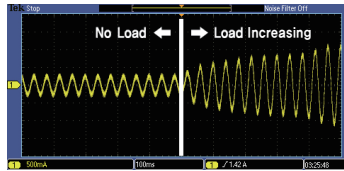
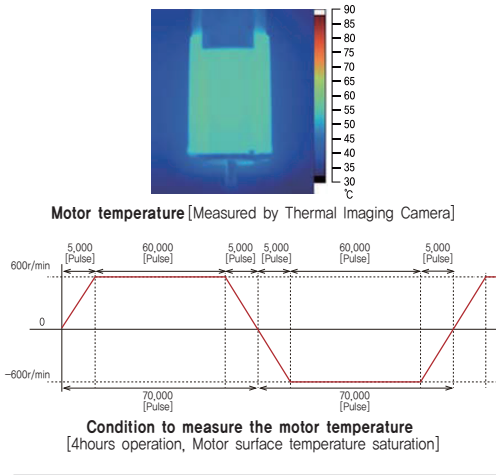

Example of the Motor Current Control according to load

5 High Torque

(Motor Current Setting)

Ezi-SERVOII can increase the motor current up to 150% by setting the Run Current by parameter. Therefore acceleration and deceleration characteristics and torque characteristics at low speed can be increased.

Ezi-SERVOII can improve the torque in the low speed range by about 30%.

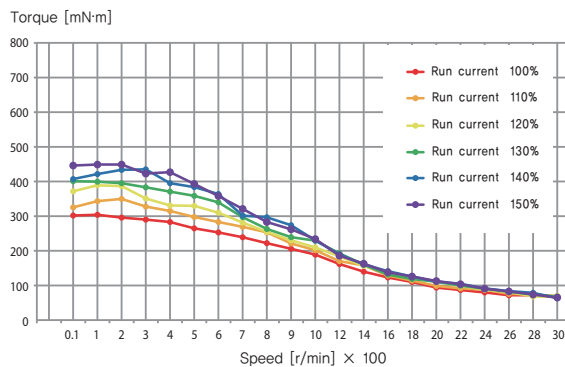

※ The torque at low speed is improved about 30%.

Measured Condition : Drive = Ezi-SERVOII-EC-MI-56L
Motor Voltage = DC24V
Input Voltage = DC24V

6 No Hunting

Ezi-SERVOII utilizes the unique characteristics of stepping motors and locks itself into the desired target position, preventing vibration and eliminating Null Hunt which happens to the conventional servo systems.

This feature is especially useful in applications such as vision systems in which system oscillation and vibration could be a problem.

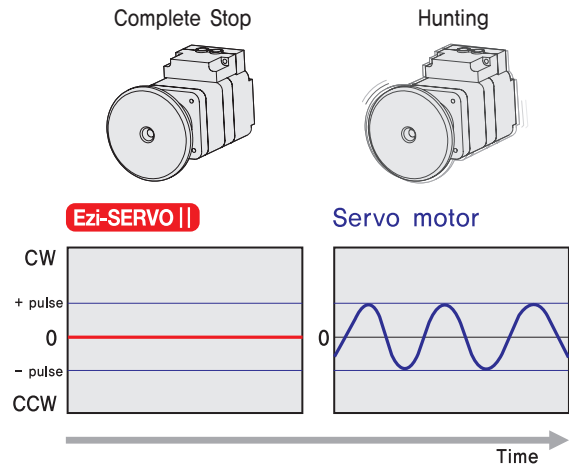

7 Smooth and Accurate Operation

Ezi-SERVOII is a high-precision servo drive, using a high-resolution encoder with 20,000 pulses/revolution. Unlike a conventional Microstep drive, the on-board high performance MCU (Micro Controller Unit) performs vector control and filtering, producing a smooth rotational control with minimum ripples.

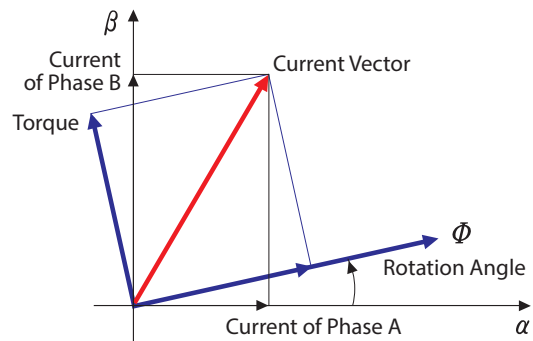

8 High Response

Similar to conventional stepping motors, Ezi-SERVO II instantly synchronizes with command pulses providing fast positional response. Ezi-SERVO II is the optimal choice when zero-speed stability and rapid motions within a short distance are required. Traditional servo motor systems have a natural delay called settling time between the command input signals and the resultant motion because of the constant monitoring of the current position.

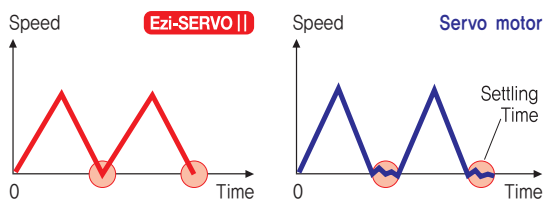

10 High Torque / Continuous Operation

Compared with common stepping motors and drives, Ezi-SERVO II motion control systems can maintain a high torque state over relatively long period of time. This means that Ezi-SERVO II continuously operates without loss of position under 100% of the load. Unlike conventional Microstep drives, Ezi-SERVO II exploits continuous high torque operation during high speed motion due to its innovative optimum current phase control.

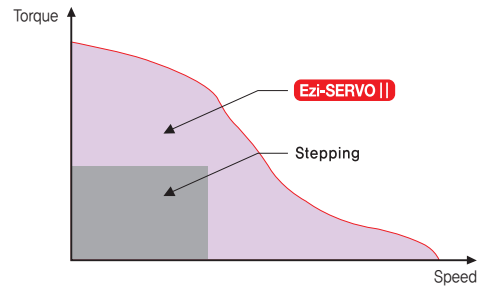

9 High Resolution

The unit of the position command can be divided precisely. (Max. 20,000 pulses/revolution)

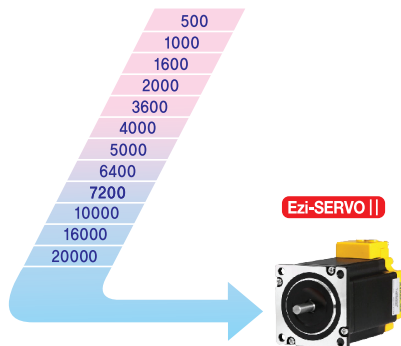

11 High Speed

The Ezi-SERVO II operates well at high speed without the loss of synchronism or positioning error. Ezi-SERVO II's ability to monitor current position continuously enables the stepping motor to generate high torque, even under a 100% load condition.

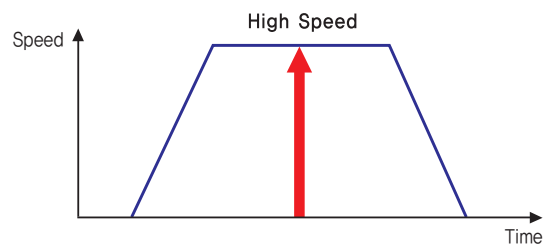

Advantages over Open-Loop Stepping System Drive

1. Positioning is reliable without loss of synchronism.
2. It can hold stable position and automatically recover to the original position even after experiencing positioning error due to external forces, such as mechanical vibration or vertical positional holding.
3. Ezi-SERVO II utilizes 100% of rated motor torque, contrary to a conventional open-loop stepping driver that can use up to 50% of the rated motor torque due to the loss of synchronism.
4. Ezi-SERVO II can operate at high speed due to load-dependent current control, while open-loop stepping drives use a constant current control at all speed ranges without considering load variations. (Max Speed : 3,000r/min)

Advantages over Servo Motor Controller

1. Tuning is not required. (Automatic gain adjustment in response to a load change)
2. It can maintain the stable holding position without oscillation after completion of positioning.
3. Positioning is fast due to the independent control by on-board MCU.
4. Operation is constant during rapid short-stroke movement due to instantaneous positioning.

● Ezi-SERVO II EtherCAT MINI Part Numbering

Ezi-SERVO II-EC-MI-42S-A-BK-PN10

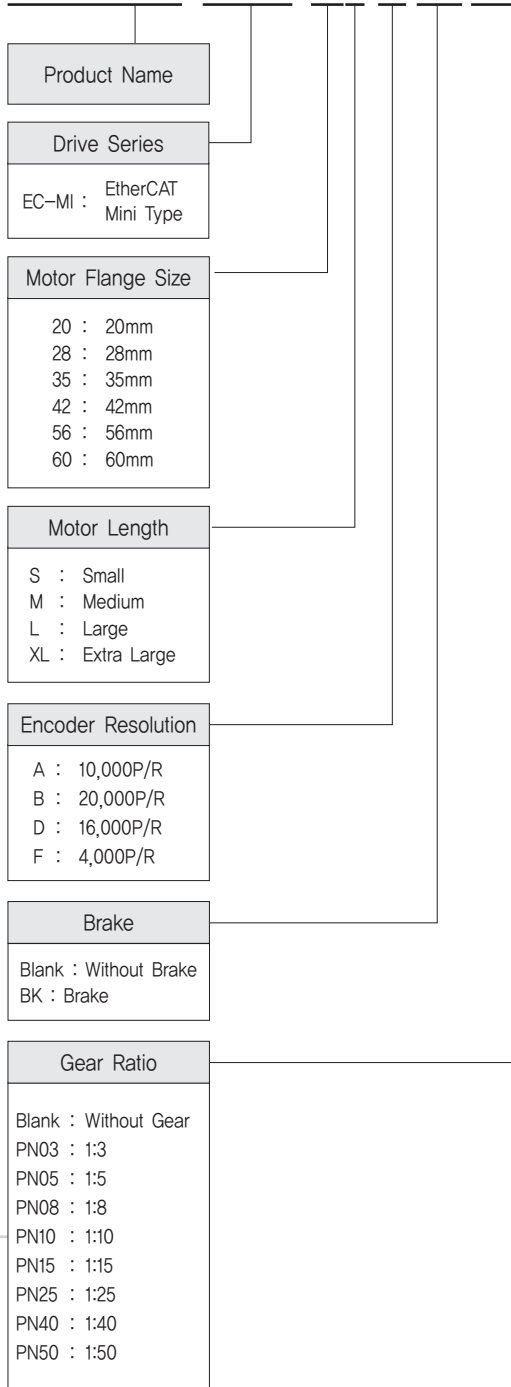

FASTECH Ezi-SERVO II EtherCAT MINI

● Standard Combination

Unit Part Number	Motor Model Number	Drive Model Number
Ezi-SERVO II-EC-MI-20M-F	EzM2-20M-F	EzS2-EC-MI-20M-F
Ezi-SERVO II-EC-MI-20L-F	EzM2-20L-F	EzS2-EC-MI-20L-F
Ezi-SERVO II-EC-MI-28S-D	EzM2-28S-D	EzS2-EC-MI-28S-D
Ezi-SERVO II-EC-MI-28SM-D	EzM2-28SM-D	EzS2-EC-MI-28S-D
Ezi-SERVO II-EC-MI-28M-D	EzM2-28M-D	EzS2-EC-MI-28M-D
Ezi-SERVO II-EC-MI-28MM-D	EzM2-28MM-D	EzS2-EC-MI-28M-D
Ezi-SERVO II-EC-MI-28L-D	EzM2-28L-D	EzS2-EC-MI-28L-D
Ezi-SERVO II-EC-MI-28LM-D	EzM2-28LM-D	EzS2-EC-MI-28L-D
Ezi-SERVO II-EC-MI-35M-D	EzM2-35M-D	EzS2-EC-MI-35M-D
Ezi-SERVO II-EC-MI-35MM-D	EzM2-35MM-D	EzS2-EC-MI-35M-D
Ezi-SERVO II-EC-MI-35L-D	EzM2-35L-D	EzS2-EC-MI-35L-D
Ezi-SERVO II-EC-MI-35LM-D	EzM2-35LM-D	EzS2-EC-MI-35L-D
Ezi-SERVO II-EC-MI-42S-A	EzM2-42S-A	EzS2-EC-MI-42S-A
Ezi-SERVO II-EC-MI-42S-B	EzM2-42S-B	EzS2-EC-MI-42S-B
Ezi-SERVO II-EC-MI-42M-A	EzM2-42M-A	EzS2-EC-MI-42M-A
Ezi-SERVO II-EC-MI-42M-B	EzM2-42M-B	EzS2-EC-MI-42M-B
Ezi-SERVO II-EC-MI-42L-A	EzM2-42L-A	EzS2-EC-MI-42L-A
Ezi-SERVO II-EC-MI-42L-B	EzM2-42L-B	EzS2-EC-MI-42L-B
Ezi-SERVO II-EC-MI-42XL-A	EzM2-42XL-A	EzS2-EC-MI-42XL-A
Ezi-SERVO II-EC-MI-42XL-B	EzM2-42XL-B	EzS2-EC-MI-42XL-B
Ezi-SERVO II-EC-MI-56S-A	EzM2-56S-A	EzS2-EC-MI-56S-A
Ezi-SERVO II-EC-MI-56S-B	EzM2-56S-B	EzS2-EC-MI-56S-B
Ezi-SERVO II-EC-MI-56M-A	EzM2-56M-A	EzS2-EC-MI-56M-A
Ezi-SERVO II-EC-MI-56M-B	EzM2-56M-B	EzS2-EC-MI-56M-B
Ezi-SERVO II-EC-MI-56L-A	EzM2-56L-A	EzS2-EC-MI-56L-A
Ezi-SERVO II-EC-MI-56L-B	EzM2-56L-B	EzS2-EC-MI-56L-B
Ezi-SERVO II-EC-MI-60S-A	EzM2-60S-A	EzS2-EC-MI-60S-A
Ezi-SERVO II-EC-MI-60S-B	EzM2-60S-B	EzS2-EC-MI-60S-B
Ezi-SERVO II-EC-MI-60M-A	EzM2-60M-A	EzS2-EC-MI-60M-A
Ezi-SERVO II-EC-MI-60M-B	EzM2-60M-B	EzS2-EC-MI-60M-B
Ezi-SERVO II-EC-MI-60L-A	EzM2-60L-A	EzS2-EC-MI-60L-A
Ezi-SERVO II-EC-MI-60L-B	EzM2-60L-B	EzS2-EC-MI-60L-B

* When places an order for Stopper type 28mm, 35mm motor, please write "M" additionally after motor length of unit part number, (e.g., Ezi-SERVO II-EC-MI-28LM-D, Ezi-SERVO II-EC-MI-35LM-D)

● Combination with Gearbox

Unit Part Number	Motor Model Number	Drive Model Number	Gear Ratio
Ezi-SERVO II -EC-MI-56L-A-PN3	EzM2-56L-A-PN3	EzS2-EC-MI-56L-A	1:3
Ezi-SERVO II -EC-MI-56L-B-PN3	EzM2-56L-B-PN3	EzS2-EC-MI-56L-B	
Ezi-SERVO II -EC-MI-56L-A-PN5	EzM2-56L-A-PN5	EzS2-EC-MI-56L-A	1:5
Ezi-SERVO II -EC-MI-56L-B-PN5	EzM2-56L-B-PN5	EzS2-EC-MI-56L-B	
Ezi-SERVO II -EC-MI-56L-A-PN8	EzM2-56L-A-PN8	EzS2-EC-MI-56L-A	1:8
Ezi-SERVO II -EC-MI-56L-B-PN8	EzM2-56L-B-PN8	EzS2-EC-MI-56L-B	
Ezi-SERVO II -EC-MI-56L-A-PN10	EzM2-56L-A-PN10	EzS2-EC-MI-56L-A	1:10
Ezi-SERVO II -EC-MI-56L-B-PN10	EzM2-56L-B-PN10	EzS2-EC-MI-56L-B	
Ezi-SERVO II -EC-MI-56L-A-PN15	EzM2-56L-A-PN15	EzS2-EC-MI-56L-A	1:15
Ezi-SERVO II -EC-MI-56L-B-PN15	EzM2-56L-B-PN15	EzS2-EC-MI-56L-B	
Ezi-SERVO II -EC-MI-56L-A-PN25	EzM2-56L-A-PN25	EzS2-EC-MI-56L-A	1:25
Ezi-SERVO II -EC-MI-56L-B-PN25	EzM2-56L-B-PN25	EzS2-EC-MI-56L-B	
Ezi-SERVO II -EC-MI-56L-A-PN40	EzM2-56L-A-PN40	EzS2-EC-MI-56L-A	1:40
Ezi-SERVO II -EC-MI-56L-B-PN40	EzM2-56L-B-PN40	EzS2-EC-MI-56L-B	
Ezi-SERVO II -EC-MI-56L-A-PN50	EzM2-56L-A-PN50	EzS2-EC-MI-56L-A	1:50
Ezi-SERVO II -EC-MI-56L-B-PN50	EzM2-56L-B-PN50	EzS2-EC-MI-56L-B	
Ezi-SERVO II -EC-MI-60S-A-PN3	EzM2-60S-A-PN3	EzS2-EC-MI-60S-A	1:3
Ezi-SERVO II -EC-MI-60S-B-PN3	EzM2-60S-B-PN3	EzS2-EC-MI-60S-B	
Ezi-SERVO II -EC-MI-60S-A-PN5	EzM2-60S-A-PN5	EzS2-EC-MI-60S-A	1:5
Ezi-SERVO II -EC-MI-60S-B-PN5	EzM2-60S-B-PN5	EzS2-EC-MI-60S-B	
Ezi-SERVO II -EC-MI-60S-A-PN8	EzM2-60S-A-PN8	EzS2-EC-MI-60S-A	1:8
Ezi-SERVO II -EC-MI-60S-B-PN8	EzM2-60S-B-PN8	EzS2-EC-MI-60S-B	
Ezi-SERVO II -EC-MI-60S-A-PN10	EzM2-60S-A-PN10	EzS2-EC-MI-60S-A	1:10
Ezi-SERVO II -EC-MI-60S-B-PN10	EzM2-60S-B-PN10	EzS2-EC-MI-60S-B	
Ezi-SERVO II -EC-MI-60S-A-PN15	EzM2-60S-A-PN15	EzS2-EC-MI-60S-A	1:15
Ezi-SERVO II -EC-MI-60S-B-PN15	EzM2-60S-B-PN15	EzS2-EC-MI-60S-B	
Ezi-SERVO II -EC-MI-60S-A-PN25	EzM2-60S-A-PN25	EzS2-EC-MI-60S-A	1:25
Ezi-SERVO II -EC-MI-60S-B-PN25	EzM2-60S-B-PN25	EzS2-EC-MI-60S-B	
Ezi-SERVO II -EC-MI-60S-A-PN40	EzM2-60S-A-PN40	EzS2-EC-MI-60S-A	1:40
Ezi-SERVO II -EC-MI-60S-B-PN40	EzM2-60S-B-PN40	EzS2-EC-MI-60S-B	
Ezi-SERVO II -EC-MI-60S-A-PN50	EzM2-60S-A-PN50	EzS2-EC-MI-60S-A	1:50
Ezi-SERVO II -EC-MI-60S-B-PN50	EzM2-60S-B-PN50	EzS2-EC-MI-60S-B	
Ezi-SERVO II -EC-MI-60M-A-PN3	EzM2-60M-A-PN3	EzS2-EC-MI-60M-A	1:3
Ezi-SERVO II -EC-MI-60M-B-PN3	EzM2-60M-B-PN3	EzS2-EC-MI-60M-B	
Ezi-SERVO II -EC-MI-60M-A-PN5	EzM2-60M-A-PN5	EzS2-EC-MI-60M-A	1:5
Ezi-SERVO II -EC-MI-60M-B-PN5	EzM2-60M-B-PN5	EzS2-EC-MI-60M-B	
Ezi-SERVO II -EC-MI-60M-A-PN8	EzM2-60M-A-PN8	EzS2-EC-MI-60M-A	1:8
Ezi-SERVO II -EC-MI-60M-B-PN8	EzM2-60M-B-PN8	EzS2-EC-MI-60M-B	
Ezi-SERVO II -EC-MI-60M-A-PN10	EzM2-60M-A-PN10	EzS2-EC-MI-60M-A	1:10
Ezi-SERVO II -EC-MI-60M-B-PN10	EzM2-60M-B-PN10	EzS2-EC-MI-60M-B	
Ezi-SERVO II -EC-MI-60M-A-PN15	EzM2-60M-A-PN15	EzS2-EC-MI-60M-A	1:15
Ezi-SERVO II -EC-MI-60M-B-PN15	EzM2-60M-B-PN15	EzS2-EC-MI-60M-B	
Ezi-SERVO II -EC-MI-60M-A-PN25	EzM2-60M-A-PN25	EzS2-EC-MI-60M-A	1:25
Ezi-SERVO II -EC-MI-60M-B-PN25	EzM2-60M-B-PN25	EzS2-EC-MI-60M-B	
Ezi-SERVO II -EC-MI-60M-A-PN40	EzM2-60M-A-PN40	EzS2-EC-MI-60M-A	1:40
Ezi-SERVO II -EC-MI-60M-B-PN40	EzM2-60M-B-PN40	EzS2-EC-MI-60M-B	
Ezi-SERVO II -EC-MI-60M-A-PN50	EzM2-60M-A-PN50	EzS2-EC-MI-60M-A	1:50
Ezi-SERVO II -EC-MI-60M-B-PN50	EzM2-60M-B-PN50	EzS2-EC-MI-60M-B	
Ezi-SERVO II -EC-MI-60L-A-PN3	EzM2-60L-A-PN3	EzS2-EC-MI-60L-A	1:3
Ezi-SERVO II -EC-MI-60L-B-PN3	EzM2-60L-B-PN3	EzS2-EC-MI-60L-B	
Ezi-SERVO II -EC-MI-60L-A-PN5	EzM2-60L-A-PN5	EzS2-EC-MI-60L-A	1:5
Ezi-SERVO II -EC-MI-60L-B-PN5	EzM2-60L-B-PN5	EzS2-EC-MI-60L-B	
Ezi-SERVO II -EC-MI-60L-A-PN8	EzM2-60L-A-PN8	EzS2-EC-MI-60L-A	1:8
Ezi-SERVO II -EC-MI-60L-B-PN8	EzM2-60L-B-PN8	EzS2-EC-MI-60L-B	
Ezi-SERVO II -EC-MI-60L-A-PN10	EzM2-60L-A-PN10	EzS2-EC-MI-60L-A	1:10
Ezi-SERVO II -EC-MI-60L-B-PN10	EzM2-60L-B-PN10	EzS2-EC-MI-60L-B	
Ezi-SERVO II -EC-MI-60L-A-PN15	EzM2-60L-A-PN15	EzS2-EC-MI-60L-A	1:15
Ezi-SERVO II -EC-MI-60L-B-PN15	EzM2-60L-B-PN15	EzS2-EC-MI-60L-B	
Ezi-SERVO II -EC-MI-60L-A-PN25	EzM2-60L-A-PN25	EzS2-EC-MI-60L-A	1:25
Ezi-SERVO II -EC-MI-60L-B-PN25	EzM2-60L-B-PN25	EzS2-EC-MI-60L-B	
Ezi-SERVO II -EC-MI-60L-A-PN40	EzM2-60L-A-PN40	EzS2-EC-MI-60L-A	1:40
Ezi-SERVO II -EC-MI-60L-B-PN40	EzM2-60L-B-PN40	EzS2-EC-MI-60L-B	
Ezi-SERVO II -EC-MI-60L-A-PN50	EzM2-60L-A-PN50	EzS2-EC-MI-60L-A	1:50
Ezi-SERVO II -EC-MI-60L-B-PN50	EzM2-60L-B-PN50	EzS2-EC-MI-60L-B	

● Specifications of Drive

Motor Model	EzM2-20 series	EzM2-28 series	EzM2-35 series	EzM2-42 series	EzM2-56 series	EzM2-60 series						
Drive Model	EzS2-EC-MI-20 series	EzS2-EC-MI-28 series	EzS2-EC-MI-35 series	EzS2-EC-MI-42 series	EzS2-EC-MI-56 series	EzS2-EC-MI-60 series						
Input Voltage	DC24V±10%											
Control Method	Closed-loop control with 32 bit MCU											
Current Consumption	Max. 500mA (Except motor current)											
Operating Condition	Ambient Temperature	· In Use: 0~50°C *2 · In Storage: -20~70°C										
	Humidity	· In Use: 35~85% RH (Non-Condensing) · In Storage: 10~90% RH (Non-Condensing)										
	Vib. Resist.	0.5g										
Function	Rotation Speed	0~3,000r/min *1										
	Resolution	Encoder Resolution [P/R]		Configurable Resolution [P/R]								
		4,000	500	1,000	1,600	2,000	3,600	4,000	5,000	6,400	7,200	10,000
		10,000	500	1,000	1,600	2,000	3,600	5,000	6,400	7,200	10,000	
16,000		500	1,000	1,600	2,000	3,600	5,000	6,400	7,200	10,000	16,000	
20,000	500	1,000	1,600	2,000	3,600	5,000	6,400	7,200	10,000	20,000		
		(Selectable by parameter)										
Error Type	Over Current Error, Over Speed Error, Position Tracking Error, Over Load Error, Over Temperature Error, Over Regenerated Voltage Error, Motor Connect Error, Encoder Connect Error, In-Position Error, ROM Error, Position Overflow Error											
EtherCAT	Supported Protocol	CoE (CiA 402 Drive Profile), FoE (Firmware Download)										
	Supported Mode	Profile Position Mode, Homing Mode, Cyclic Synchronous Position Mode										
	Synchronization	Free Run, SM Event, DC SYNC Event										
I/O Signal	Input Signals	3 dedicated inputs (LIMIT+, LIMIT-, ORIGIN), 3 programmable inputs (Photocoupler Input)										
	Output Signals	2 programmable outputs (Photocoupler Output), 1 Brake output										

*1 : Up to the resolution of 10,000P/R, maximum speed can be reached by 3,000r/min and with the resolution more than 10,000P/R, maximum speed shall be reduced accordingly.

*2 : EzS2-EC-MI-56, 60 series should be installed on a heat sink or a structure capable of heat dissipation.

● Dimensions of Drive [mm]

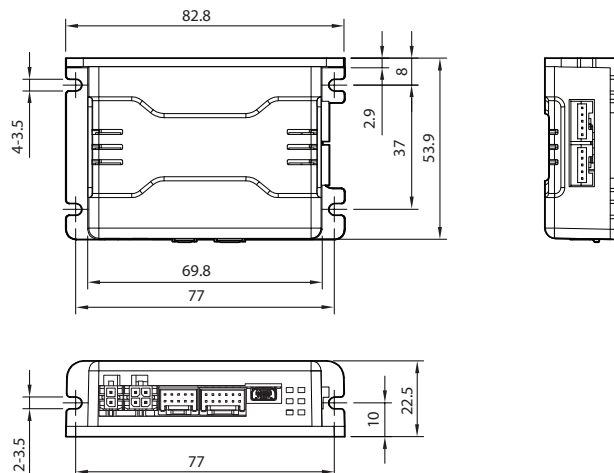

● Specifications of Motor

MODEL	EzM2-20 series		EzM2-28 series			EzM2-35 series		EzM2-42 series					
	UNIT	20M	20L	28S	28M	28L	35M	35L	42S	42M	42L	42XL	
DRIVE METHOD	-	Bipolar											
NUMBER OF PHASES	-	2 Phase											
CURRENT per PHASE	A/Phase	0,5	0,5	0,95	0,95	0,95	1,5	1,5	1,2	1,2	1,2	1,2	
MAXIMUM HOLDING TORQUE	N·m	0,016	0,025	0,069	0,098	0,118	0,13	0,23	0,32	0,44	0,5	0,65	
ROTOR INERTIA	g·cm ²	2,5	3,3	9,0	13	18	15	20	35	54	77	114	
WEIGHTS	kg	0,080	0,104	0,147	0,204	0,232	0,194	0,226	0,294	0,357	0,426	0,564	
LENGTH(L)	mm	28	38	32	45	50	32	36	34	40	48	60	
PERMISSIBLE RADIAL LOAD	DIS-TANCE FROM END OF SHAFT	3mm	N	18	18	30	30	30	22	22	22	22	
		8mm		30	30	38	38	38	26	26	26	26	26
		13mm		-	-	53	53	53	33	33	33	33	33
		18mm		-	-	-	-	-	46	46	46	46	46
PERMISSIBLE AXIAL LOAD	N	Lower than motor Unit's Weight											
INSULATION RESISTANCE	MΩ	Min, 100(When measured with a DC500V insulation resistance meter)											
INSULATION CLASS	-	CLASS B(130°C)											
OPERATING TEMPERATURE	°C	0 ~ 55											

MODEL	EzM2-56 series			EzM2-60 series					
	UNIT	56S	56M	56L	60S	60M	60L		
DRIVE METHOD	-	Bipolar							
NUMBER OF PHASES	-	2 Phase							
CURRENT per PHASE	A/Phase	3,0	3,0	3,0	4,0	4,0	4,0		
MAXIMUM HOLDING TORQUE	N·m	0,64	1,0	1,5	0,88	1,28	2,4		
ROTOR INERTIA	g·cm ²	180	280	520	240	490	690		
WEIGHTS	kg	0,608	0,784	1,230	0,693	0,856	1,419		
LENGTH(L)	mm	46	55	80	47	56	85		
PERMISSIBLE RADIAL LOAD	DIS-TANCE FROM END OF SHAFT	3mm	N	52	52	52	70	70	70
		8mm		65	65	65	87	87	87
		13mm		85	85	85	114	114	114
		18mm		123	123	123	165	165	165
PERMISSIBLE AXIAL LOAD	N	Lower than motor Unit's Weight							
INSULATION RESISTANCE	MΩ	Min, 100(When measured with a DC500V insulation resistance meter)							
INSULATION CLASS	-	CLASS B(130°C)							
OPERATING TEMPERATURE	°C	0 ~ 55							

Torque Characteristics of Motor

Ezi-SERVO II-EC-MI-20 series

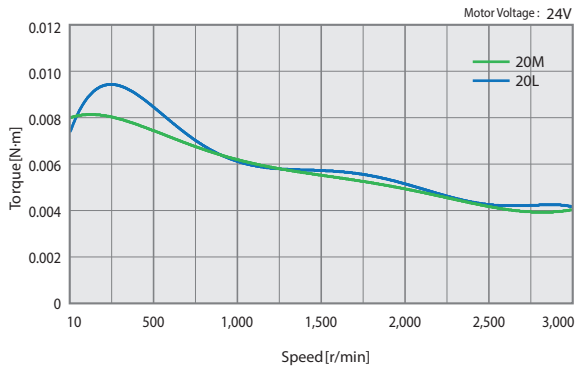

Ezi-SERVO II-EC-MI-28 series

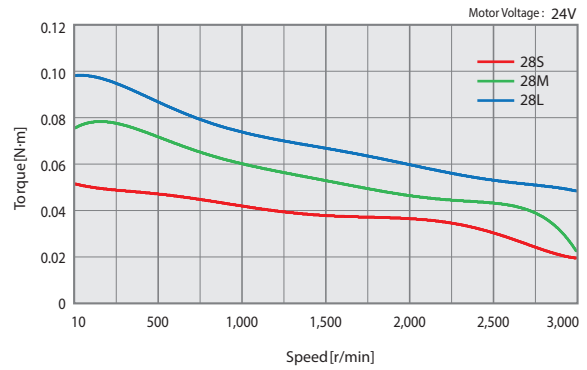

Ezi-SERVO II-EC-MI-35 series

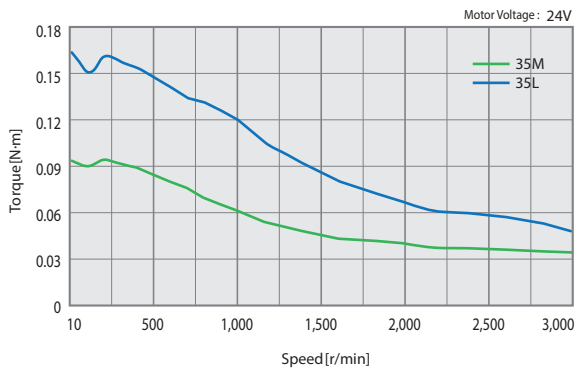

Ezi-SERVO II-EC-MI-42 series

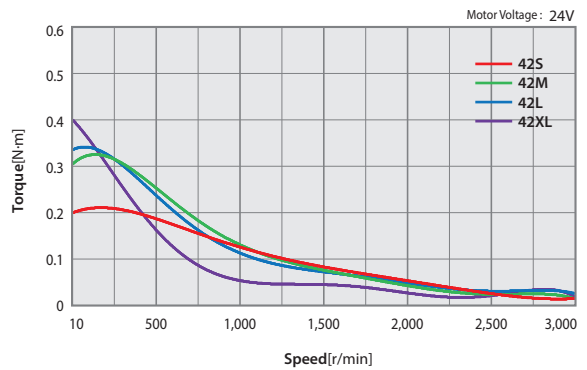

Ezi-SERVO II-EC-MI-56 series

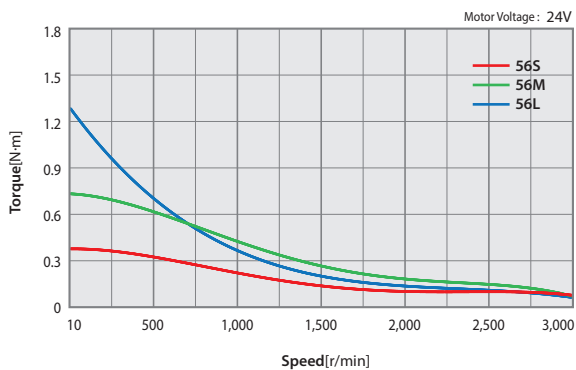

Ezi-SERVO II-EC-MI-60 series

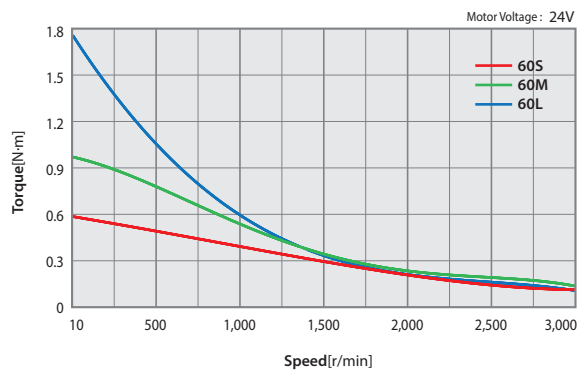

● Dimensions of Motor [mm]

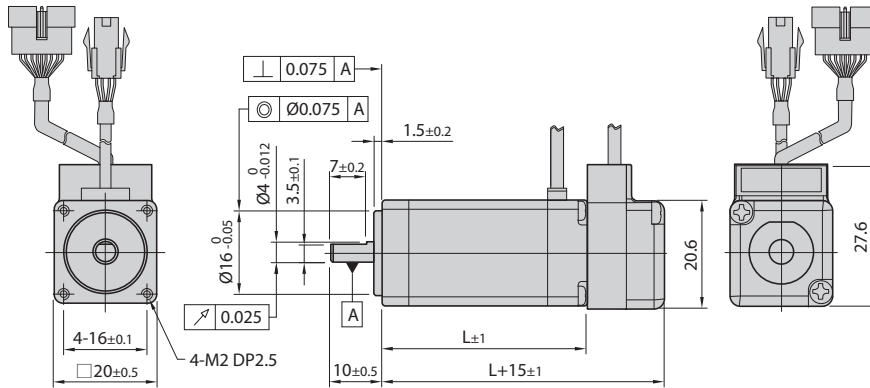

20mm

Model name	Length(L)
EzM2-20M	28
EzM2-20L	38

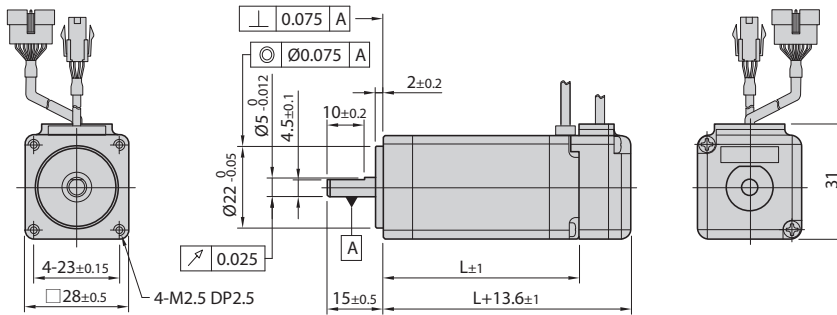

28mm

Model name	Length(L)
EzM2-28S	32
EzM2-28M	45
EzM2-28L	50

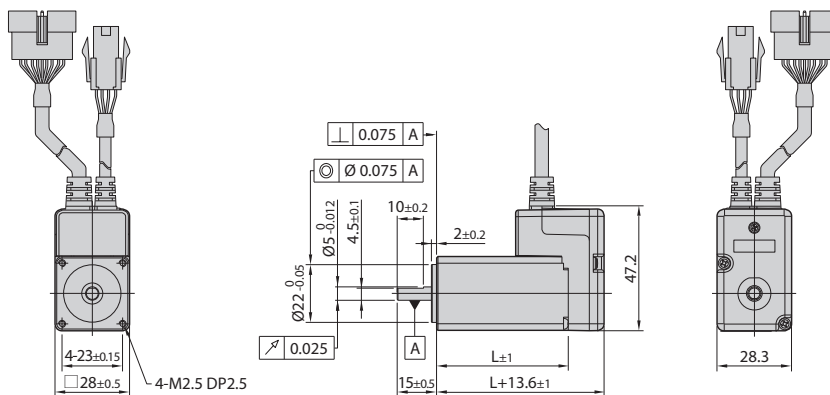

28mm (Stopper type)

Model name	Length(L)
EzM2-28SM	32
EzM2-28MM	45
EzM2-28LM	50

※ When ordering 28mm Stopper type of motor, please add "M" after standard motor model number.

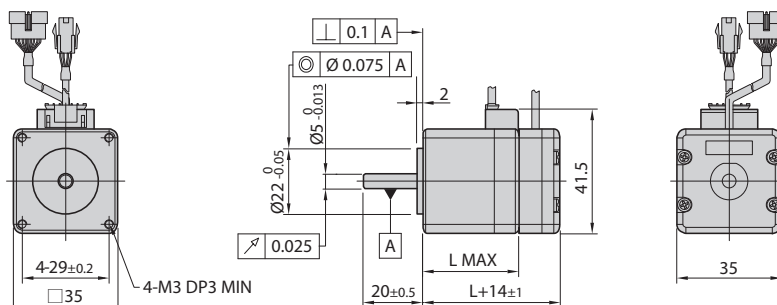

35mm

Model name	Length(L)
EzM2-35M	32
EzM2-35L	36

● Dimensions of Motor [mm]

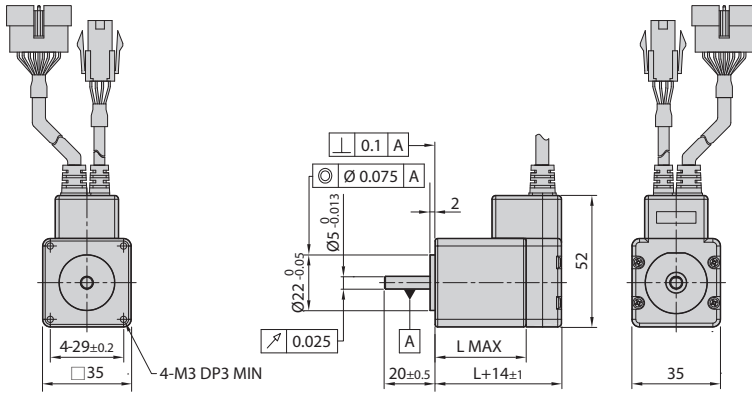

35mm (Stopper type)

Model name	Length(L)
EzM2-35MM	32
EzM2-35LM	36

※ When ordering 35mm Stopper type of motor, please add "M" after standard motor model number.

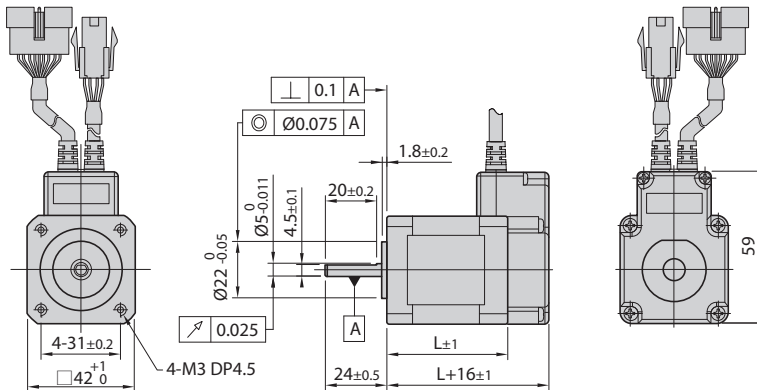

42mm

Model name	Length(L)
EzM2-42S	34
EzM2-42M	40
EzM2-42L	48
EzM2-42XL	60

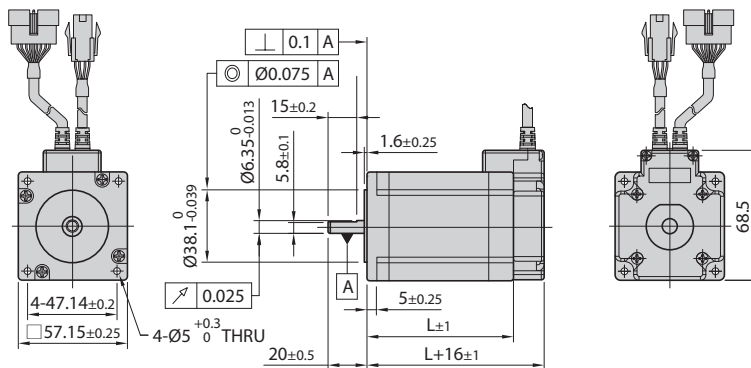

56mm

Model name	Length(L)
EzM2-56S	46
EzM2-56M	55
EzM2-56L	80

※ There are 2 kinds size of front shaft diameter for EzM2-56 series as Ø6.35 and Ø8.0.

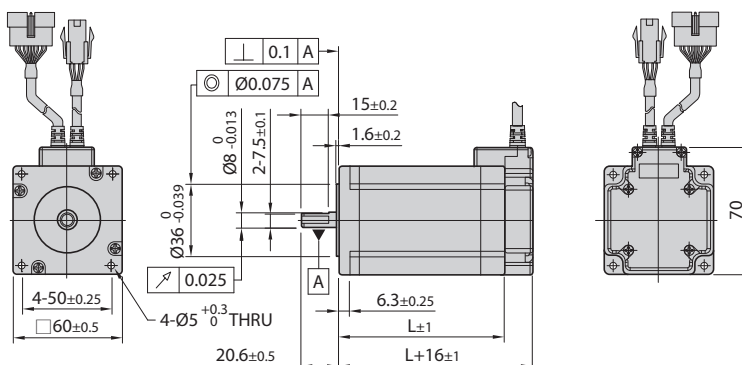

60mm

Model name	Length(L)
EzM2-60S	47
EzM2-60M	56
EzM2-60L	85

Specifications of Motor with Brake

Unit Part Number	Motor Model Number	Electromagnetic Brake					Motor Unit Weight [kg]	Permissible Radial Load [N]				Permissible Axial Load [N]
		Type	Voltage Input [V]	Rated Current [A]	Power Consumption [W]	Static Friction Torque [N · m]		Distance from End of Shaft [mm]				
								3	8	13	18	
Ezi-SERVO II -EC-MI-42S-■-BK	EzM2-42S-■-BK	Non-excitation run Type	DC24V ±10%	0,2	5	0,2	0,55	22	26	33	46	Must be Lower than Unit's Weight
Ezi-SERVO II -EC-MI-42M-■-BK	EzM2-42M-■-BK						0,62					
Ezi-SERVO II -EC-MI-42L-■-BK	EzM2-42L-■-BK						0,69					
Ezi-SERVO II -EC-MI-42XL-■-BK	EzM2-42XL-■-BK						0,82					
Ezi-SERVO II -EC-MI-56S-■-BK	EzM2-56S-■-BK			0,27	6,6	0,7	1,03	52	65	85	123	
Ezi-SERVO II -EC-MI-56M-■-BK	EzM2-56M-■-BK						1,20					
Ezi-SERVO II -EC-MI-56L-■-BK	EzM2-56L-■-BK						1,65					
Ezi-SERVO II -EC-MI-60S-■-BK	EzM2-60S-■-BK						1,11					
Ezi-SERVO II -EC-MI-60M-■-BK	EzM2-60M-■-BK			1,30	70	87	114	165				
Ezi-SERVO II -EC-MI-60L-■-BK	EzM2-60L-■-BK			1,86								

- * The code of encoder resolution will be marked in "■"
- * Electronic Brake cannot be used for braking. Position hold purpose only when power OFF.
- * The weight means Motor Unit Weight including Motor and Electronic Brake.
- * Motor Model Number is combined model name of Motor and Brake.
- * Motor specification and torque characteristic are same as Standard Motor.

* Brake Operation Timing Chart

Ezi-SERVO II EtherCAT MINI controls Brake by Drive automatically. Please refer to below Timing Chart when Brake is controlled by the upper controller other than using Ezi-SERVO II EtherCAT MINI Brake control. Otherwise, Drive might malfunction and loads might fall down. Also, please do not operate Brake during motor operation to prevent damage.

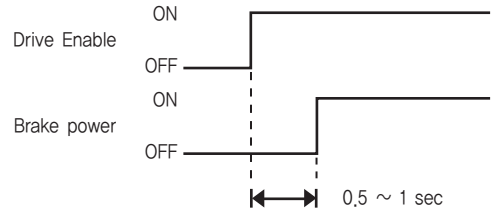

● Dimensions of Motor with Brake [mm]

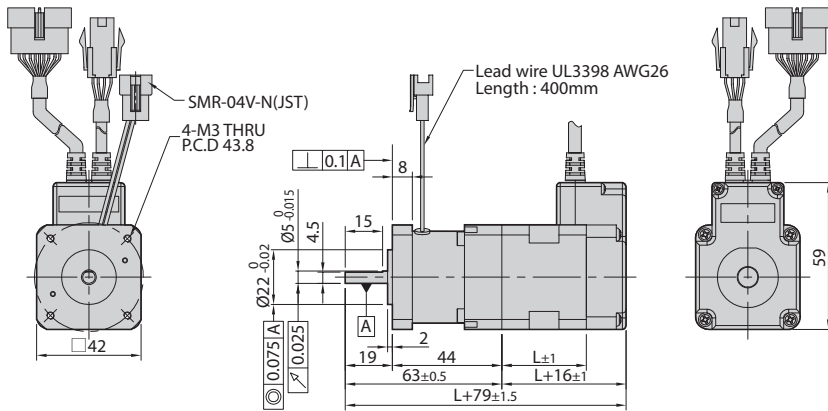

42mm

Model Name	Length(L)
EzM2-42S	34
EzM2-42M	40
EzM2-42L	48
EzM2-42XL	60

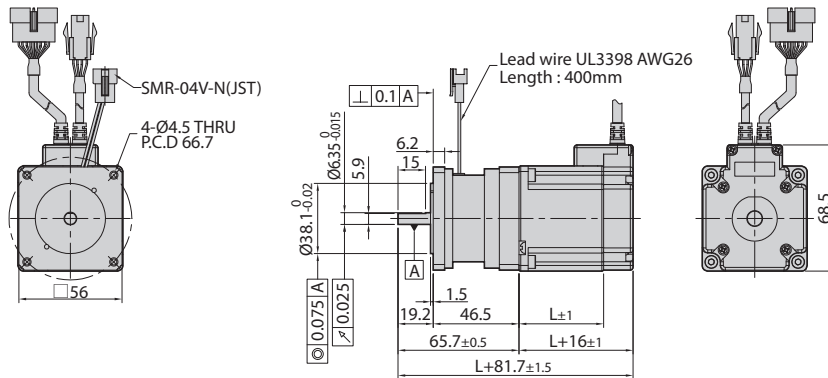

56mm

Model Name	Length(L)
EzM2-56S	46
EzM2-56M	55
EzM2-56L	80

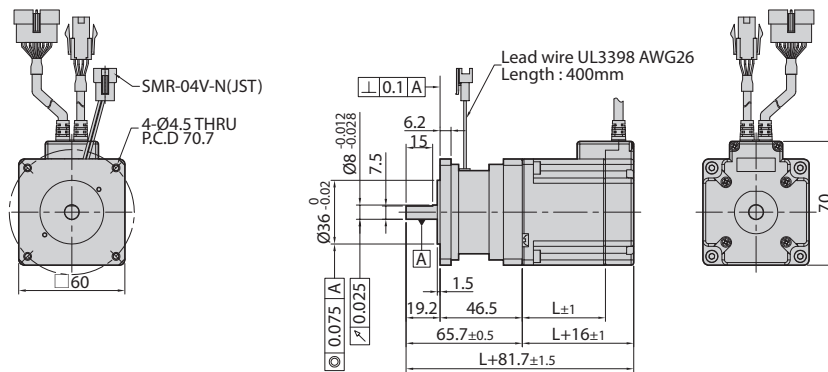

60mm

Model Name	Length(L)
EzM2-60S	47
EzM2-60M	56
EzM2-60L	85

● How to Read Specifications

Unit Part Number	① Maximum Holding Torque [N·m]	② Rotor Inertia Moment [kg·m ²]	③ Backlash [arcmin]	④ Angle Transmission Error [arcmin]	⑤ Gear Ratio	⑥ Resolution (10,000 P/R Standard)	⑦ Permissible Torque [N·m]	⑧ Instantaneous Maximum Torque [N·m]	⑨ Permissible Speed Range [r/min]	⑩ Unit Weight [kg]	⑪ Permissible Radial Load (At Center of Axis) [N]	⑫ Permissible Axial Load [N]
Ezi-SERVO II -EC-MI-42S-■-PN3	0,57	35x10 ⁻⁷	3	5	3	0,012°	6	12	0~1000	0,76	240	270
Ezi-SERVO II -EC-MI-42S-■-PN5	0,95				5	0,0072°	9	18	0~600		290	330
Ezi-SERVO II -EC-MI-42S-■-PN8	1,52				8	0,0045°	9	18	0~375		340	410
Ezi-SERVO II -EC-MI-42S-■-PN10	1,90				10	0,0036°	6	12	0~300		360	450
Ezi-SERVO II -EC-MI-42S-■-PN15	2,76	35x10 ⁻⁷	5	7	15	0,0024°	6	12	0~200	0,91	410	540
Ezi-SERVO II -EC-MI-42S-■-PN25	4,60				25	0,00144°	9	18	0~120		490	640
Ezi-SERVO II -EC-MI-42S-■-PN40	7,36				40	0,0009°	9	18	0~75		570	640
Ezi-SERVO II -EC-MI-42S-■-PN50	9,00				50	0,00072°	9	18	0~60		620	640

Description of Specification Items

No.	Item	Description
①	Maximum Holding Torque	This is the maximum torque that can be exerted through the gearbox when the motor is stopped. (Based on 100% of stop current) Use the torque below the permissible torque of the gearbox.
②	Rotor Inertia Moment	It is the value of the moment of inertia of the motor.
③	Backlash	It is the gap between the gear and the gear, and it is the angle at which the gearbox shaft moves without external force when stopped.
④	Angle Transmission Error	This is the transmission characteristic of the gearbox, which means the difference between the theoretical rotation angle and the actual rotation angle of the output shaft.
⑤	Gear Ratio	It is the value obtained by dividing the number of output rotation by the number of input rotation.
⑥	Resolution	This is the angle at which the gearbox output shaft moves when the motor is driven by 1 pulse.
⑦	Permissible Torque	It refers to the maximum value of the torque that can be continuously applied to the output shaft of the gearbox during constant speed operation. (When the input rotation speed is 3,000r/min and the lifetime of the motor becomes 20,000 hours)
⑧	Instantaneous Maximum Torque	This is the maximum torque allowed to the output shaft of the gearbox during acceleration/deceleration.
⑨	Permissible Speed Range	It is the range of rotation speed based on the output shaft of the gearbox.
⑩	Unit Weight	It is the sum of the weight of the gearbox and the motor.
⑪	Permissible Radial Load	It is the maximum value of the load applied in the direction perpendicular to the gearbox output shaft.
⑫	Permissible Axial Load	It is the maximum value of the load applied in the axial direction to the gearbox output shaft.

● Specifications of Motor with Gearbox

42_{mm}

Unit Part Number	Maximum Holding Torque [N·m]	Rotor Inertia Moment [kg·m ²]	Backlash [arcmin]	Angle Transmission Error [arcmin]	Gear Ratio	Resolution (10,000 P/R Standard)	Permissible Torque [N·m]	Instantaneous Maximum Torque [N·m]	Permissible Speed Range [r/min]	Unit Weight [kg]	Permissible Radial Load (At Center of Axis) [N]	Permissible Axial Load [N]
Ezi-SERVO II-EC-MI-42S-■-PN3	0,57	35x10 ⁻⁷	3	5	3	0,012°	6	12	0~1000	0,76	240	270
Ezi-SERVO II-EC-MI-42S-■-PN5	0,95				5	0,0072°	9	18	0~600		290	330
Ezi-SERVO II-EC-MI-42S-■-PN8	1,52				8	0,0045°	9	18	0~375		340	410
Ezi-SERVO II-EC-MI-42S-■-PN10	1,90				10	0,0036°	6	12	0~300		360	450
Ezi-SERVO II-EC-MI-42S-■-PN15	2,76		5	7	15	0,0024°	6	12	0~200	0,91	410	540
Ezi-SERVO II-EC-MI-42S-■-PN25	4,60				25	0,00144°	9	18	0~120		490	640
Ezi-SERVO II-EC-MI-42S-■-PN40	7,36				40	0,0009°	9	18	0~75		570	640
Ezi-SERVO II-EC-MI-42S-■-PN50	9,00				50	0,00072°	9	18	0~60		620	640
Ezi-SERVO II-EC-MI-42M-■-PN3	0,85	54x10 ⁻⁷	3	5	3	0,012°	6	12	0~1000	0,81	240	270
Ezi-SERVO II-EC-MI-42M-■-PN5	1,42				5	0,0072°	9	18	0~600		290	330
Ezi-SERVO II-EC-MI-42M-■-PN8	2,28				8	0,0045°	9	18	0~375		340	410
Ezi-SERVO II-EC-MI-42M-■-PN10	2,85				10	0,0036°	6	12	0~300		360	450
Ezi-SERVO II-EC-MI-42M-■-PN15	4,14		5	7	15	0,0024°	6	12	0~200	0,97	410	540
Ezi-SERVO II-EC-MI-42M-■-PN25	6,90				25	0,00144°	9	18	0~120		490	640
Ezi-SERVO II-EC-MI-42M-■-PN40	9,00				40	0,0009°	9	18	0~75		570	640
Ezi-SERVO II-EC-MI-42M-■-PN50	9,00				50	0,00072°	9	18	0~60		620	640
Ezi-SERVO II-EC-MI-42L-■-PN3	0,92	77x10 ⁻⁷	3	5	3	0,012°	6	12	0~1000	0,89	240	270
Ezi-SERVO II-EC-MI-42L-■-PN5	1,54				5	0,0072°	9	18	0~600		290	330
Ezi-SERVO II-EC-MI-42L-■-PN8	2,47				8	0,0045°	9	18	0~375		340	410
Ezi-SERVO II-EC-MI-42L-■-PN10	3,09				10	0,0036°	6	12	0~300		360	450
Ezi-SERVO II-EC-MI-42L-■-PN15	4,49		5	7	15	0,0024°	6	12	0~200	1,04	410	540
Ezi-SERVO II-EC-MI-42L-■-PN25	7,49				25	0,00144°	9	18	0~120		490	640
Ezi-SERVO II-EC-MI-42L-■-PN40	9,00				40	0,0009°	9	18	0~75		570	640
Ezi-SERVO II-EC-MI-42L-■-PN50	9,00				50	0,00072°	9	18	0~60		620	640
Ezi-SERVO II-EC-MI-42XL-■-PN3	1,45	114x10 ⁻⁷	3	5	3	0,012°	6	12	0~1000	1,03	240	270
Ezi-SERVO II-EC-MI-42XL-■-PN5	2,42				5	0,0072°	9	18	0~600		290	330
Ezi-SERVO II-EC-MI-42XL-■-PN8	3,87				8	0,0045°	9	18	0~375		340	410
Ezi-SERVO II-EC-MI-42XL-■-PN10	4,84				10	0,0036°	6	12	0~300		360	450
Ezi-SERVO II-EC-MI-42XL-■-PN15	6,00		5	7	15	0,0024°	6	12	0~200	1,18	410	540
Ezi-SERVO II-EC-MI-42XL-■-PN25	9,00				25	0,00144°	9	18	0~120		490	640
Ezi-SERVO II-EC-MI-42XL-■-PN40	9,00				40	0,0009°	9	18	0~75		570	640
Ezi-SERVO II-EC-MI-42XL-■-PN50	9,00				50	0,00072°	9	18	0~60		620	640

* The code of encoder resolution will be marked in "■"

● Specifications of Motor with Gearbox

56mm

Unit Part Number	Maximum Holding Torque [N·m]	Rotor Inertia Moment [kg·m ²]	Backlash [arcmin]	Angle Transmission Error [arcmin]	Gear Ratio	Resolution (10,000 P/R Standard)	Permissible Torque [N·m]	Instantaneous Maximum Torque [N·m]	Permissible Speed Range [r/min]	Unit Weight [kg]	Permissible Radial Load (At Center of Axis) [N]	Permissible Axial Load [N]
Ezi-SERVO II-EC-MI-56S-■-PN3	1,1	180x10 ⁻⁷	3	5	3	0,012°	18	35	0~1000	1,75	430	310
Ezi-SERVO II-EC-MI-56S-■-PN5	1,9				5	0,0072°	27	50	0~600		510	390
Ezi-SERVO II-EC-MI-56S-■-PN8	3,0				8	0,0045°	27	50	0~375		600	480
Ezi-SERVO II-EC-MI-56S-■-PN10	3,8				10	0,0036°	18	35	0~300		640	530
Ezi-SERVO II-EC-MI-56S-■-PN15	5,5				15	0,0024°	18	35	0~200	2,05	740	630
Ezi-SERVO II-EC-MI-56S-■-PN25	9,3				25	0,00144°	27	50	0~120		870	790
Ezi-SERVO II-EC-MI-56S-■-PN40	14,9				40	0,0009°	27	50	0~75		1000	970
Ezi-SERVO II-EC-MI-56S-■-PN50	18,6				50	0,00072°	27	50	0~60		1100	1100
Ezi-SERVO II-EC-MI-56M-■-PN3	2,0	280x10 ⁻⁷	3	5	3	0,012°	18	35	0~1000	1,92	430	310
Ezi-SERVO II-EC-MI-56M-■-PN5	3,4				5	0,0072°	27	50	0~600		510	390
Ezi-SERVO II-EC-MI-56M-■-PN8	5,4				8	0,0045°	27	50	0~375		600	480
Ezi-SERVO II-EC-MI-56M-■-PN10	6,8				10	0,0036°	18	35	0~300		640	530
Ezi-SERVO II-EC-MI-56M-■-PN15	9,9				15	0,0024°	18	35	0~200	2,23	740	630
Ezi-SERVO II-EC-MI-56M-■-PN25	16,6				25	0,00144°	27	50	0~120		870	790
Ezi-SERVO II-EC-MI-56M-■-PN40	27,0				40	0,0009°	27	50	0~75		1000	970
Ezi-SERVO II-EC-MI-56M-■-PN50	27,0				50	0,00072°	27	50	0~60		1100	1100
Ezi-SERVO II-EC-MI-56L-■-PN3	4,0	520x10 ⁻⁷	3	5	3	0,012°	18	35	0~1000	2,37	430	310
Ezi-SERVO II-EC-MI-56L-■-PN5	6,8				5	0,0072°	27	50	0~600		510	390
Ezi-SERVO II-EC-MI-56L-■-PN8	10,8				8	0,0045°	27	50	0~375		600	480
Ezi-SERVO II-EC-MI-56L-■-PN10	13,6				10	0,0036°	18	35	0~300		640	530
Ezi-SERVO II-EC-MI-56L-■-PN15	18,0				15	0,0024°	18	35	0~200	2,67	740	630
Ezi-SERVO II-EC-MI-56L-■-PN25	27,0				25	0,00144°	27	50	0~120		870	790
Ezi-SERVO II-EC-MI-56L-■-PN40	27,0				40	0,0009°	27	50	0~75		1000	970
Ezi-SERVO II-EC-MI-56L-■-PN50	27,0				50	0,00072°	27	50	0~60		1100	1100

* The code of encoder resolution will be marked in "■"

● Specifications of Motor with Gearbox

60_{mm}

Unit Part Number	Maximum Holding Torque [N·m]	Rotor Inertia Moment [kg·m ²]	Backlash [arcmin]	Angle Transmission Error [arcmin]	Gear Ratio	Resolution (10,000 P/R Standard)	Permissible Torque [N·m]	Instantaneous Maximum Torque [N·m]	Permissible Speed Range [r/min]	Unit Weight [kg]	Permissible Radial Load (At Center of Axis) [N]	Permissible Axial Load [N]
Ezi-SERVO II-EC-MI-60S-■-PN3	1,5	240x10 ⁻⁷	3	5	3	0,012°	18	35	0~1000	1,84	430	310
Ezi-SERVO II-EC-MI-60S-■-PN5	2,5				5	0,0072°	27	50	0~600		510	390
Ezi-SERVO II-EC-MI-60S-■-PN8	4,0				8	0,0045°	27	50	0~375		600	480
Ezi-SERVO II-EC-MI-60S-■-PN10	5,1				10	0,0036°	18	35	0~300		640	530
Ezi-SERVO II-EC-MI-60S-■-PN15	7,4				15	0,0024°	18	35	0~200	740	630	2,13
Ezi-SERVO II-EC-MI-60S-■-PN25	12,3				25	0,00144°	27	50	0~120	870	790	
Ezi-SERVO II-EC-MI-60S-■-PN40	19,8				40	0,0009°	27	50	0~75	1000	970	
Ezi-SERVO II-EC-MI-60S-■-PN50	24,7				50	0,00072°	27	50	0~60	1100	1100	
Ezi-SERVO II-EC-MI-60M-■-PN3	2,6	490x10 ⁻⁷	3	5	3	0,012°	18	35	0~1000	1,20	430	310
Ezi-SERVO II-EC-MI-60M-■-PN5	4,4				5	0,0072°	27	50	0~600		510	390
Ezi-SERVO II-EC-MI-60M-■-PN8	7,0				8	0,0045°	27	50	0~375		600	480
Ezi-SERVO II-EC-MI-60M-■-PN10	8,8				10	0,0036°	18	35	0~300		640	530
Ezi-SERVO II-EC-MI-60M-■-PN15	12,8				15	0,0024°	18	35	0~200	740	630	2,30
Ezi-SERVO II-EC-MI-60M-■-PN25	21,4				25	0,00144°	27	50	0~120	870	790	
Ezi-SERVO II-EC-MI-60M-■-PN40	27,0				40	0,0009°	27	50	0~75	1000	970	
Ezi-SERVO II-EC-MI-60M-■-PN50	27,0				50	0,00072°	27	50	0~60	1100	1100	
Ezi-SERVO II-EC-MI-60L-■-PN3	5,2	690x10 ⁻⁷	3	5	3	0,012°	18	35	0~1000	2,61	430	310
Ezi-SERVO II-EC-MI-60L-■-PN5	8,7				5	0,0072°	27	50	0~600		510	390
Ezi-SERVO II-EC-MI-60L-■-PN8	13,9				8	0,0045°	27	50	0~375		600	480
Ezi-SERVO II-EC-MI-60L-■-PN10	18,0				10	0,0036°	18	35	0~300		640	530
Ezi-SERVO II-EC-MI-60L-■-PN15	18,0				15	0,0024°	18	35	0~200	740	630	2,86
Ezi-SERVO II-EC-MI-60L-■-PN25	27,0				25	0,00144°	27	50	0~120	870	790	
Ezi-SERVO II-EC-MI-60L-■-PN40	27,0				40	0,0009°	27	50	0~75	1000	970	
Ezi-SERVO II-EC-MI-60L-■-PN50	27,0				50	0,00072°	27	50	0~60	1100	1100	

* The code of encoder resolution will be marked in "■"

● Dimensions of Motor with Gearbox [mm]

42mm

Unit Part Number	Motor	Stage	□ Gear Ratio	L [mm]
Ezi-SERVO II-EC-MI-42S-■-PN□	EzM2-42S-■-PN□	Single Stage	3, 5, 8, 10	34
Ezi-SERVO II-EC-MI-42M-■-PN□	EzM2-42M-■-PN□		3, 5, 8, 10	40
Ezi-SERVO II-EC-MI-42L-■-PN□	EzM2-42L-■-PN□		3, 5, 8, 10	48
Ezi-SERVO II-EC-MI-42XL-■-PN□	EzM2-42XL-■-PN□		3, 5, 8, 10	60

* The code of encoder resolution will be marked in "■"

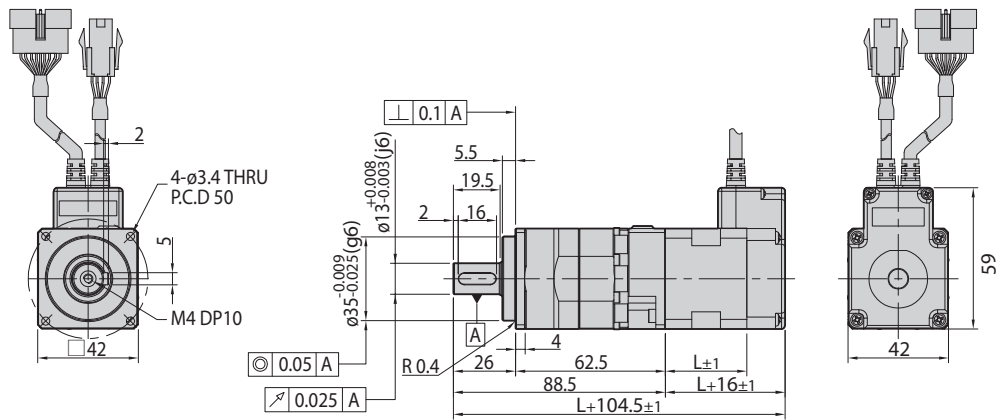

Unit Part Number	Motor	Stage	□ Gear Ratio	L [mm]
Ezi-SERVO II-EC-MI-42S-■-PN□	EzM2-42S-■-PN□	Double Stage	15, 25, 40, 50	34
Ezi-SERVO II-EC-MI-42M-■-PN□	EzM2-42M-■-PN□		15, 25, 40, 50	40
Ezi-SERVO II-EC-MI-42L-■-PN□	EzM2-42L-■-PN□		15, 25, 40, 50	48
Ezi-SERVO II-EC-MI-42XL-■-PN□	EzM2-42XL-■-PN□		15, 25, 40, 50	60

* The code of encoder resolution will be marked in "■"

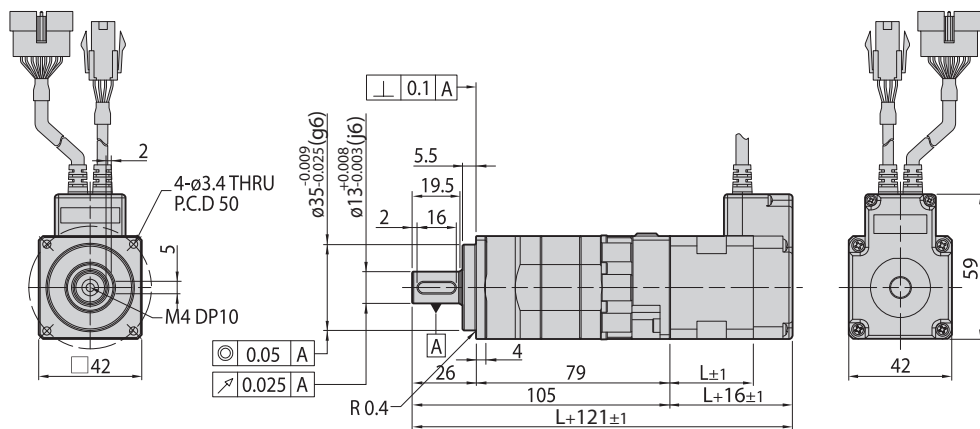

● Dimensions of Motor with Gearbox [mm]

56mm

Unit Part Number	Motor	Stage	□ Gear Ratio	L [mm]
Ezi-SERVO II -EC-MI-56S-■-PN□	EzM2-56S-■-PN□	Single Stage	3, 5, 8, 10	46
Ezi-SERVO II -EC-MI-56M-■-PN□	EzM2-56M-■-PN□		3, 5, 8, 10	55
Ezi-SERVO II -EC-MI-56L-■-PN□	EzM2-56L-■-PN□		3, 5, 8, 10	80

* The code of encoder resolution will be marked in "■"

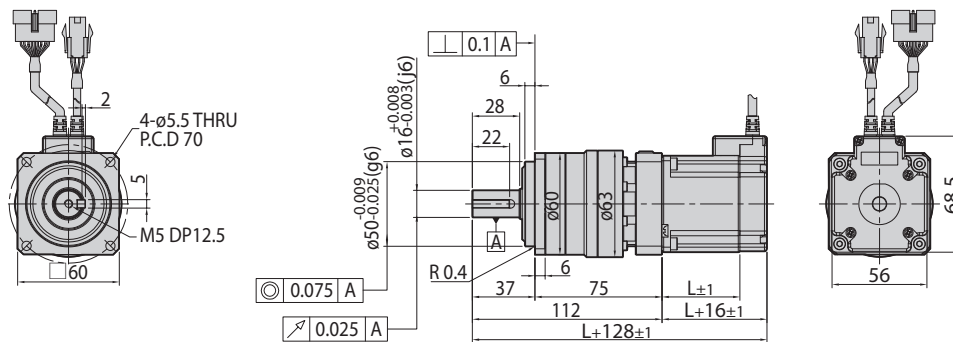

Unit Part Number	Motor	Stage	□ Gear Ratio	L [mm]
Ezi-SERVO II -EC-MI-56S-■-PN□	EzM2-56S-■-PN□	Double Stage	15, 25, 40, 50	46
Ezi-SERVO II -EC-MI-56M-■-PN□	EzM2-56M-■-PN□		15, 25, 40, 50	55
Ezi-SERVO II -EC-MI-56L-■-PN□	EzM2-56L-■-PN□		15, 25, 40, 50	80

* The code of encoder resolution will be marked in "■"

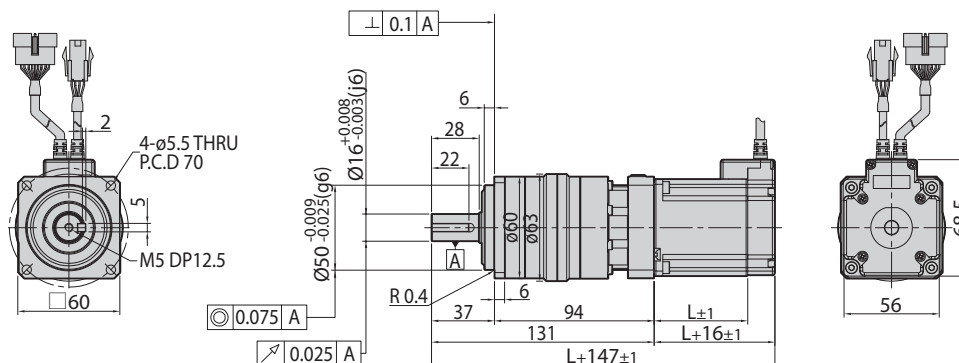

● Dimensions of Motor with Gearbox [mm]

60mm

Unit Part Number	Motor	Stage	□ Gear Ratio	L [mm]
Ezi-SERVO II-EC-MI-60S-■-PN□	EzM2-60S-■-PN□	Single Stage	3, 5, 8, 10	47
Ezi-SERVO II-EC-MI-60M-■-PN□	EzM2-60M-■-PN□		3, 5, 8, 10	56
Ezi-SERVO II-EC-MI-60L-■-PN□	EzM2-60L-■-PN□		3, 5, 8, 10	85

* The code of encoder resolution will be marked in "■"

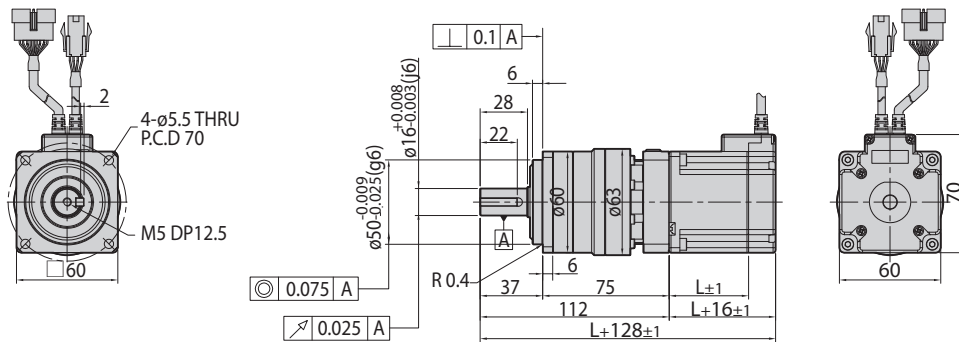

Unit Part Number	Motor	Stage	□ Gear Ratio	L [mm]
Ezi-SERVO II-EC-MI-60S-■-PN□	EzM2-60S-■-PN□	Double Stage	15, 25, 40, 50	47
Ezi-SERVO II-EC-MI-60M-■-PN□	EzM2-60M-■-PN□		15, 25, 40, 50	56
Ezi-SERVO II-EC-MI-60L-■-PN□	EzM2-60L-■-PN□		15, 25, 40, 50	85

* The code of encoder resolution will be marked in "■"

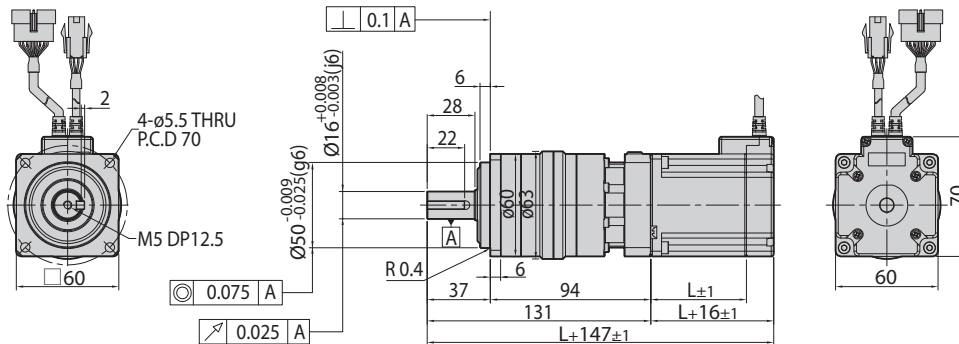

Settings and Operation

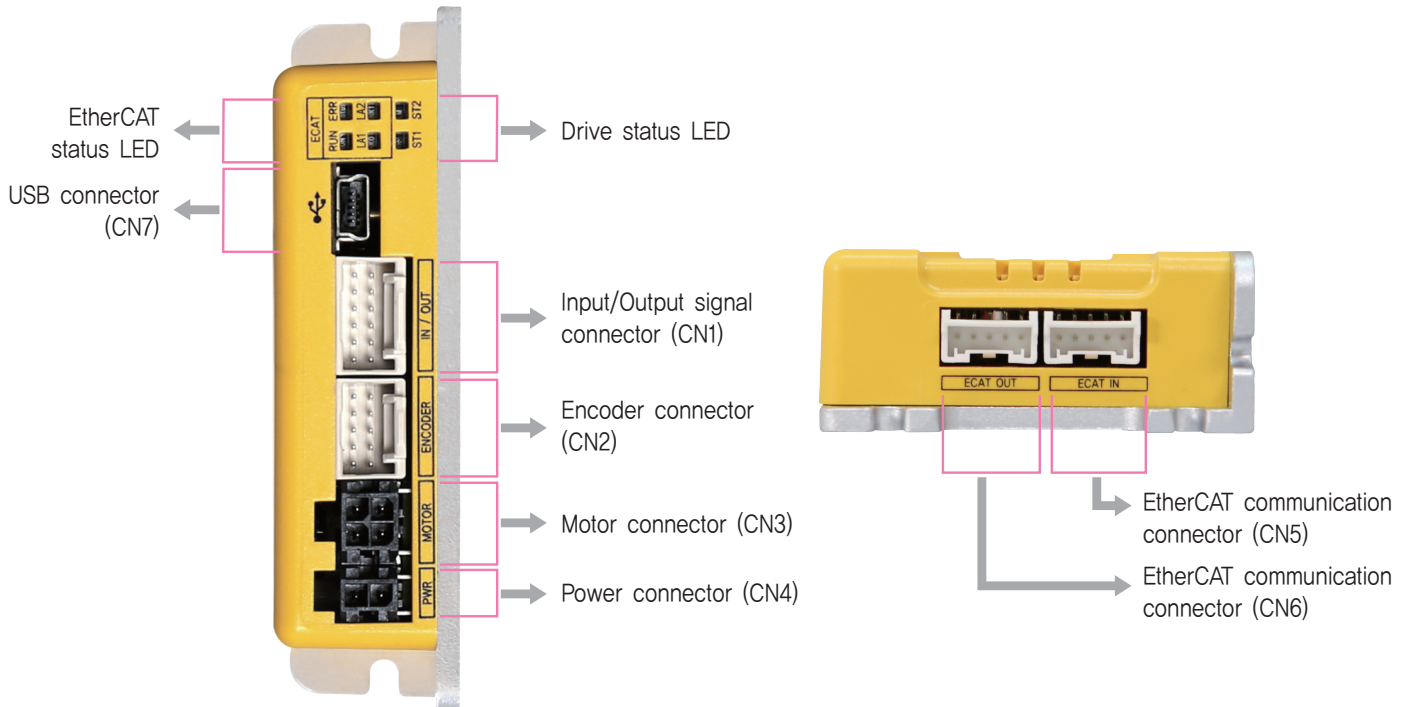

1. EtherCAT Status LED

LED indicates communication status of EtherCAT.

Name	Color	Status	Description
RUN	Green	OFF	State INIT or Power OFF
		Blinking	State PRE-OPERATIONAL
		Single Flash	State SAFE-OPERATIONAL
		ON	State OPERATIONAL
		Flickering	State BOOTSTRAP





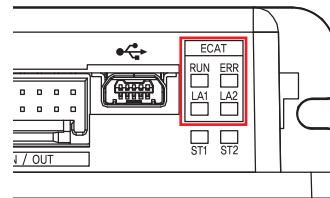



Name	Color	Status	Description
ERR	Red	OFF	No Error or Power OFF
		Blinking	Invalid Configuration
		Single Flash	Local Error
		Double Flash	Watchdog Time Out

Name	Color	Status	Description
LA1/ LA2	Green	OFF	Link not Established
		ON	Link Established
		Flickering	Link Established and in Operation



2. Drive Status LED

LED informs operation status of the drive.

LED Indication	LED Status	Description
ST1 :  ST2 :	ST1 blinks, ST2 is OFF	Servo On
ST1 :  ST2 :	ST1 is ON, ST2 is OFF	Servo Off
ST1 :  ST2 : 	ST1 and ST2 are ON	In motion
ST1 :  ST2 : 	ST1 and ST2 blink alternately	A position error is greater than the set value (Inposition Value) while the motor is stopped.
ST1 :  ST2 : 	ST1 is OFF, ST2 blinks repeatedly for a set number of times depending on the type of error.	Error

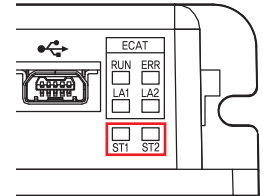

◆ List of error types by the number of ST2 LED blinking

No.	Error Type	Causes
1	Over Current Error	The current through power devices in drive exceeds the limit, ^{*1}
2	Over Speed Error	The motor speed exceeds 3,000r/min
3	Position Tracking Error	Position error value is greater than the reference value while the motor is running ^{*2}
4	Over Load Error	The motor is continuously operated more than 5 seconds under a load exceeding the max. torque.
5	Over Temperature Error	Internal temperature of the drive exceeds 85°C
6	Over Regenerative Voltage Error	Back-EMF is higher than limit value ^{*3}
7	Motor Connect Error	There is a problem with the connection between the drive and the motor
8	Encoder Connect Error	There is a problem with the connection between the drive and the encoder
10	In-Position Error	After operation is finished, position error larger than 1 pulse is continued for more than 3 seconds
12	ROM Error	Error occurs in parameter storage device(ROM)
15	Position Overflow Error	Position error value is greater than the reference value while the motor is stopped ^{*2}

*1 : Limit value depends on motor model. (Refer to the Manual)

*2 : The default setting value is 180°, and it can be changed by parameter. (Refer to the Manual)

*3 : Voltage limit of Back-EMF depends on motor model. (Refer to the Manual)

※ Please refer to user Manual for the details of protection functions.

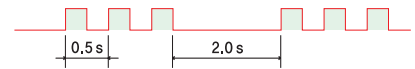

Alarm LED flash
(e.g., Position tracking error)

3. Input/Output Signal Connector(CN1)

No.	Function	I/O
1	EXT_DC24V	Input
2	EXT_GND	Input
3	BRAKE+	Output
4	BRAKE-	Output
5	LIMIT+	Input
6	LIMIT-	Input
7	ORIGIN	Input
8	Digital In1	Input
9	Digital In2	Input
10	Digital In3	Input
11	Digital Out1	Output
12	Digital Out2	Output

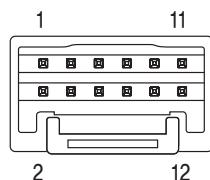

4. Encoder Connector(CN2)

No.	Function	I/O
1	A+	Input
2	A-	Input
3	B+	Input
4	B-	Input
5	Z+	Input
6	Z-	Input
7	DC5V	Output
8	GND	Output
9	F_GND	----
10	F_GND	----

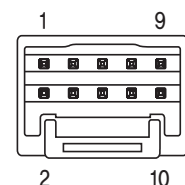

5. Motor Connector(CN3)

No.	Function	I/O
1	A Phase	Output
2	B Phase	Output
3	Ā Phase	Output
4	B̄ Phase	Output

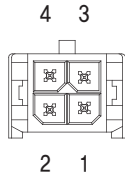

6. Power Connector(CN4)

No.	Function	I/O
1	DC24V	Input
2	GND	Input

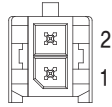

7. EtherCAT Communication Connector(CN5, CN6)

No.	Function
1	TD+
2	TD-
3	RD+
4	RD-
5	F_GND

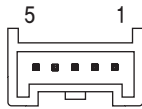

8. USB Connector(CN7)

No.	Function
1	V _{BUS}
2	D-
3	D+
4	---
5	GND

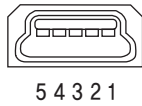

System Configuration

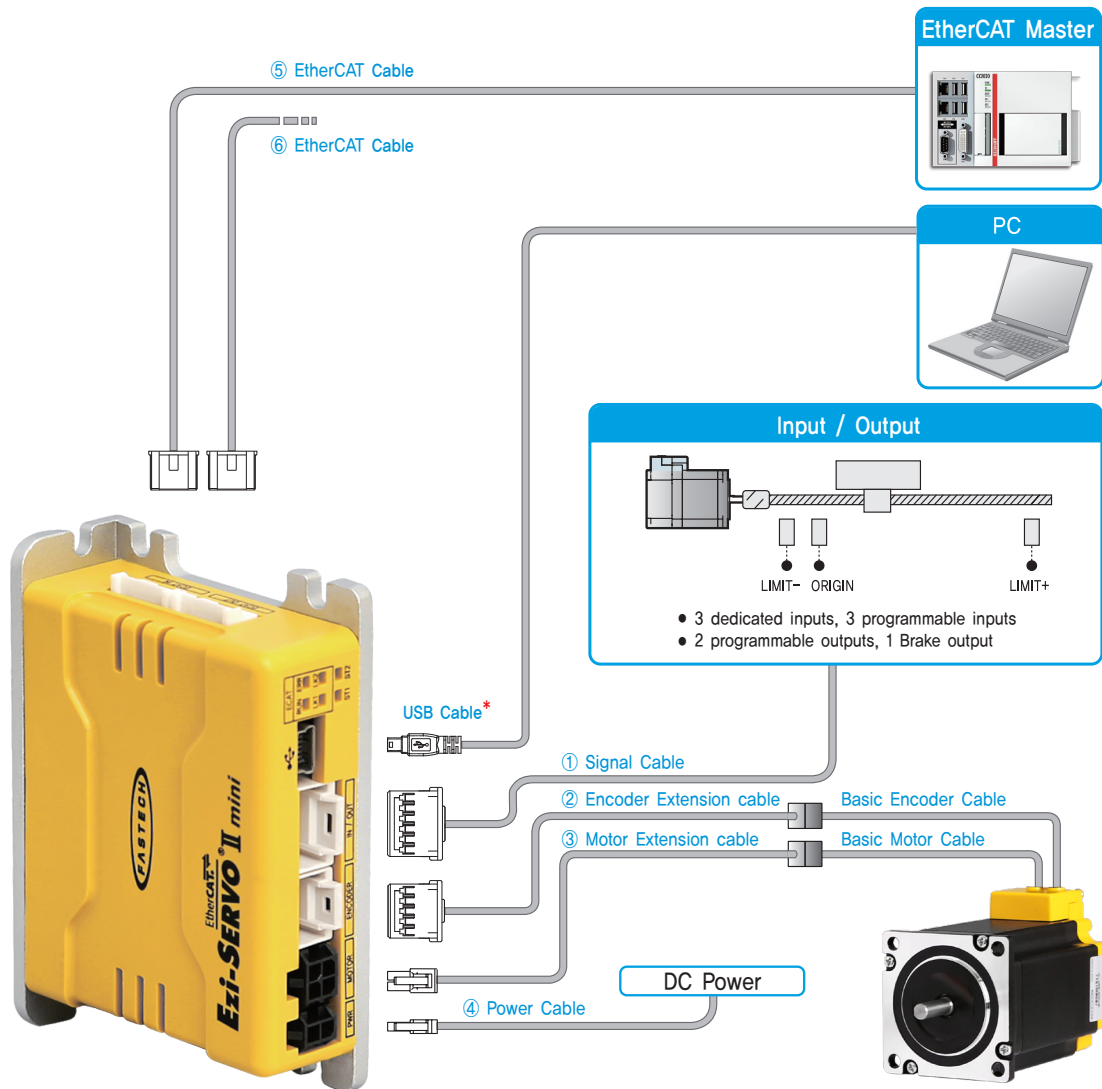

FASTECH Ezi-SERVO II EtherCAT MINI

Cable Type	Max. Length	Remarks
① Signal Cable	20m	Options (Sold separately)
② Encoder Extension Cable	20m	
③ Motor Extension Cable	20m	
④ Power Cable	2m	
⑤/⑥ EtherCAT Cable	100m	Basic cables are attached to motors.
Basic Encoder Cable	0.3m (Basic length)	
Basic Motor Cable	0.3m (Basic length)	
USB Cable	5m	* USB cables are not provided by FASTECH. We recommend using a standard USB cable (USB 2.0 Mini Type B).

1. Accessories

Connectors

These are connector specifications for drive cabling.

Purpose		Item	Part Number	Manufacturer
EtherCAT (CN5, CN6)		Housing	PAP-05V-S	JST
		Terminal	SPHD-001T-P0,5	
Power (CN4)		Housing	43025-0200	MOLEX
		Terminal	43030-0001	
Motor	Drive Side (CN3)	Housing	43025-0400	MOLEX
		Terminal	43030-0001	
	Motor Side	Housing	5557-04R	MOLEX
		Terminal	5556T	
Encoder	Drive Side (CN2)	Housing	501646-1000	MOLEX
		Terminal	501648-1000 (AWG 26~28)	
	Encoder Side	Housing	SMP-09V-NC	JST
		Terminal	SHF-001T-0,8BS	
Signal (CN1)		Housing	501646-1200	MOLEX
		Terminal	501648-1000 (AWG 26~28)	

※ The connectors above are supplied with the product. If you are using other parts, please make sure they meet the specifications.

2. Options

① Signal Cable

These are the cables to connect Ezi-SERVO II EtherCAT MINI drive and other input/output devices.

Purpose	Part Number	Length [m]	Cable Type	Remarks
Drive - I/O Device Connection	CSNR-S-001F	1	Normal Cable	Maximum Length: 20m
	CSNR-S-002F	2		
	CSNR-S-003F	3		
	CSNR-S-005F	5		
	CSNR-S-001M	1	Robot Cable	
	CSNR-S-002M	2		
	CSNR-S-003M	3		
	CSNR-S-005M	5		

* If you need cables with length(in units of 1m) not listed on the table, please contact FASTECH for more information.

② Encoder Extension Cable

These are the cables to connect Ezi-SERVO II EtherCAT MINI drive and the encoder.

Purpose	Part Number	Length [m]	Cable Type	Remarks
Drive - Basic Encoder Cable Connection	CSVIE-E-001F	1	Normal Cable	Maximum Length: 20m
	CSVIE-E-002F	2		
	CSVIE-E-003F	3		
	CSVIE-E-005F	5		
	CSVIE-E-001M	1	Robot Cable	
	CSVIE-E-002M	2		
	CSVIE-E-003M	3		
	CSVIE-E-005M	5		

* If you need cables with length(in units of 1m) not listed on the table, please contact FASTECH for more information.

③ Motor Extension Cable

These are the cables to connect Ezi-SERVO II EtherCAT MINI drive and the motor.

Purpose	Part Number	Length [m]	Cable Type	Remarks
Drive – Basic Motor Cable Connection	CSMI-M-001F	1	Normal Cable	Maximum Length: 20m
	CSMI-M-002F	2		
	CSMI-M-003F	3		
	CSMI-M-005F	5		
	CSMI-M-001M	1	Robot Cable	
	CSMI-M-002M	2		
	CSMI-M-003M	3		
	CSMI-M-005M	5		

* If you need cables with length(in units of 1m) not listed on the table, please contact FASTECH for more information.

④ Drive Power Cable

These are the cables to connect Ezi-SERVO II EtherCAT MINI drive and the power.

Purpose	Part Number	Length [m]	Cable Type	Remarks
Drive – Power Connection	CSMI-P-001F	1	Normal Cable	Maximum Length: 2m
	CSMI-P-002F	2		
	CSMI-P-001M	1	Robot Cable	
	CSMI-P-002M	2		

⑤ EtherCAT Cable (5 pin connector – RJ45)

These are the cables to connect Ezi-SERVO II EtherCAT MINI drive and Ezi-SERVO II EtherCAT, Ezi-SERVO II EtherCAT ALL R type with EtherCAT network.

Purpose	Part Number	Length [m]	Remarks
EtherCAT Connection	CGNE-EC-001F	1	<ul style="list-style-type: none"> · STP(Shielded Twisted Pair) Cable · Category 5e or higher · Maximum Length: 100m · Normal Cable
	CGNE-EC-002F	2	
	CGNE-EC-003F	3	
	CGNE-EC-005F	5	

* If you need cables with length(in units of 1m) not listed on the table or robot cables, please contact FASTECH for more information.

⑥ EtherCAT Cable (5 pin connector – 5 pin connector)

These are the cables to connect between Ezi-SERVO II EtherCAT MINI drives with EtherCAT network.

Purpose	Part Number	Length [m]	Remarks
EtherCAT Connection	CGNI-EC-001F	1	<ul style="list-style-type: none"> · STP(Shielded Twisted Pair) Cable · Category 5e or higher · Maximum Length: 100m · Normal Cable
	CGNI-EC-002F	2	
	CGNI-EC-003F	3	
	CGNI-EC-005F	5	

* If you need cables with length(in units of 1m) not listed on the table or robot cables, please contact FASTECH for more information.

External Wiring Diagram

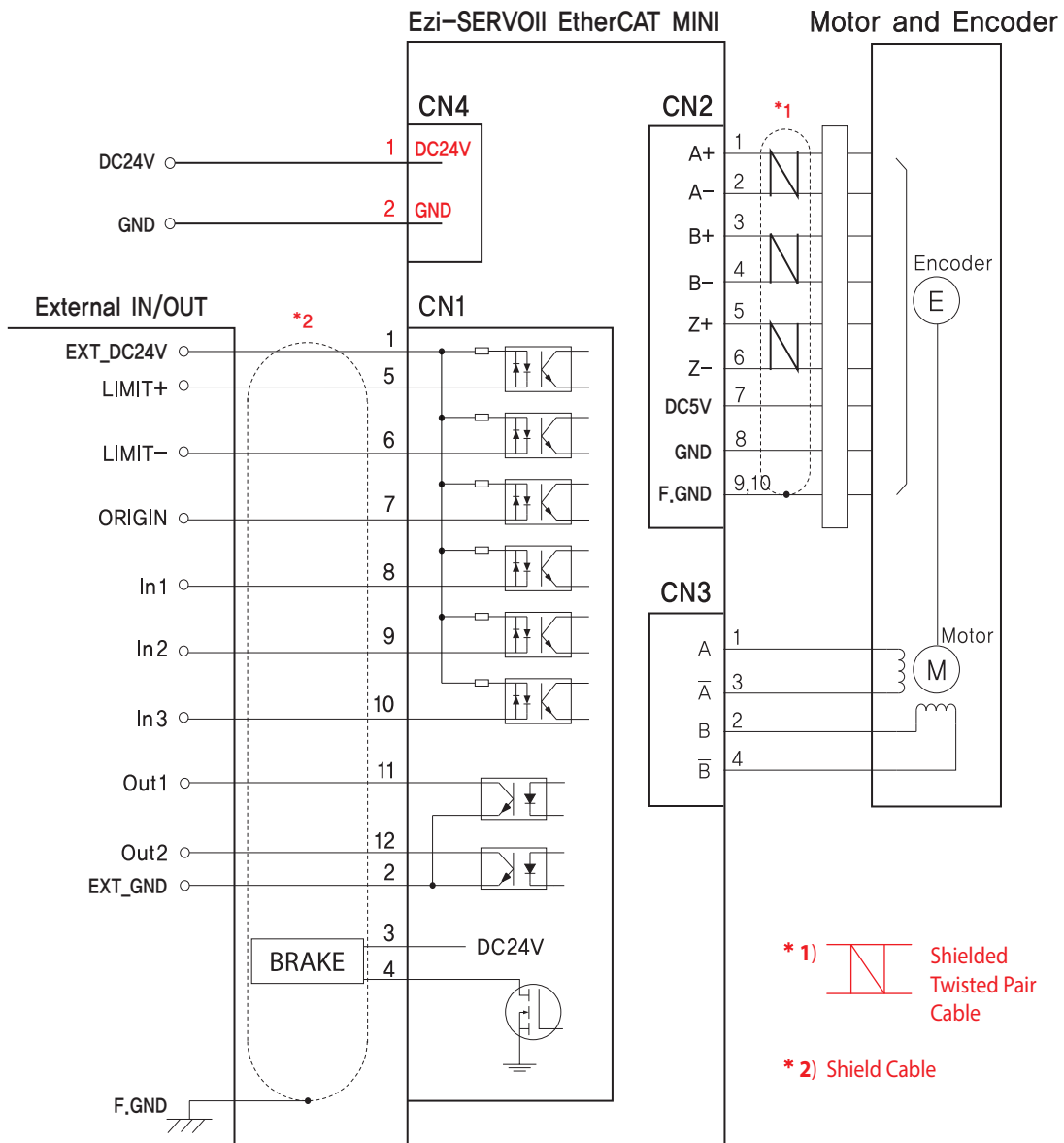

※ When connects I/O cable between controller and drive, please turn off the power of both controller and drive to prevent electric shock or to protect the drive from any damage.

CAUTION

In order to use the products listed in this catalog safely and correctly, be sure to read the instruction manual before using the product.

MEMO

MEMO



Fast, Accurate, Smooth Motion

FASTECH Co., Ltd.

Rm#1202, 401-dong, Bucheon Techno-Park,
655, Pyeongcheon-ro, Bucheon-si Gyeonggi-do,
Republic of Korea (Postal Code: 14502)
TEL : +82-32-234-6317 FAX : +82-32-234-6302
E-mail : sales@fastech-motions.com
Homepage : www.fastech-motions.com