

FASTECH

2021 / 2022

OPTION_Brake [English]

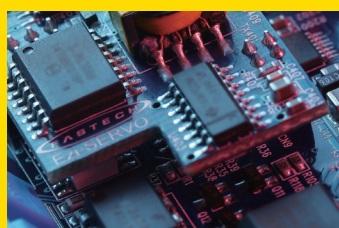
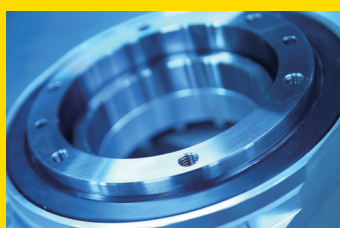

FASTECH



● Features

Characteristic

Ezi-SERVO BK series, FASTECH's new unit product, maximizes User's operational convenience with integration between Ezi-SERVO series of stepping motor and non-excitation electromagnetic brake that has big friction of brake torque and rapid brake timing.

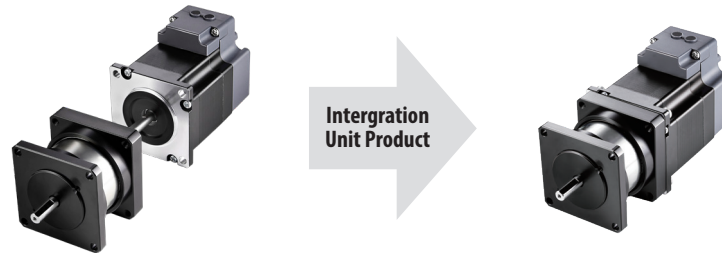

Advantage

◆ Apply non-excitation electromagnetic brake

Different from excitation type of brake that only generates braking-power by electromagnetic-power when power supplies at brake and loses brake power when power cut-off, Ezi-SERVO BK series adopts non-excitation electromagnetic brake that immediately generate friction of brake torque by inner spring's binding post-tensioning force once power cut off. So Ezi-SERVO BK series enables complete stopping of stepping motor and can forestall risks with brake's mechanical braking-power under emergency situation as like sudden blackout in machine operation.

◆ Automatic Braking during power cutoff or blackout

Ezi-SERVO BK series, Unit product, integrated between high performance of non-excitation electromagnetic brake and step motor that enables immediate braking to keep holding point and prevent falling under power cut off or blackout during operation so customer can be flexible in responding to sudden situation.

◆ Long Durability

Brake integrated into Ezi-SERVO BK series applies long durability of brake wear plate(Brake Lining) so it guarantees high durability and long life cycle.

◆ Rapid Brake Timing

Ezi-SERVO BK series, non-excitation electromagnetic brake, enables rapid braking because loaded spring closed brake can quicken rising of brake torque.

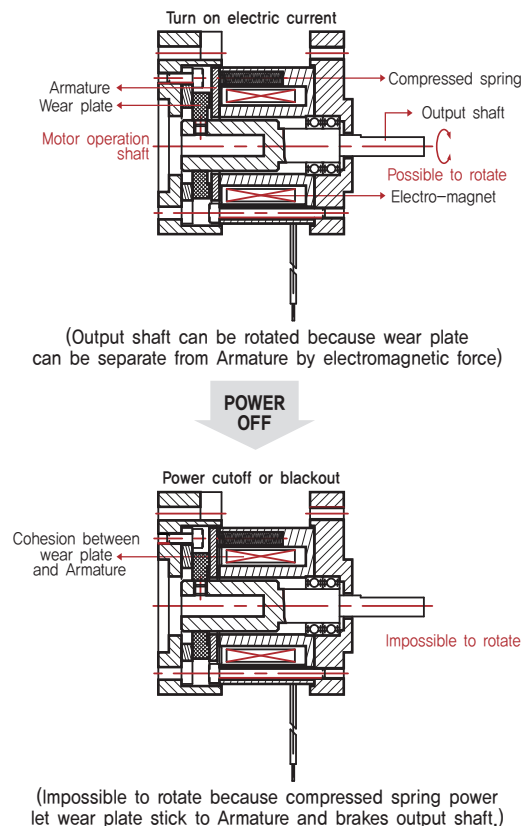

● Specifications of Brake [42mm]

Applicable Model			
Ezi-SERVO ST	Ezi-SERVO MINI	Ezi-SERVO II BT	Ezi-SERVO Plus-R
Ezi-SERVO Plus-R MINI	Ezi-SERVO ALL	Ezi-SERVO II EtherCAT	Ezi-SERVO II EtherCAT MINI
Ezi-SERVO II EtherCAT 4X	Ezi-SERVO II EtherCAT ALL	Ezi-SERVO II Plus-E	Ezi-SERVO II Plus-E MINI
Ezi-SERVO II Plus-E ALL	Ezi-SERVO II CC-Link	Ezi-STEP MPB	Ezi-STEP MINI
Ezi-STEP BT	Ezi-STEP Plus-R	Ezi-STEP Plus-R MINI	Ezi-STEP ALL
Ezi-STEP II EtherCAT	Ezi-STEP II EtherCAT MINI	Ezi-STEP II EtherCAT 4X	Ezi-STEP II Plus-E
Ezi-STEP II Plus-E MINI	Ezi-STEP II CC-Link	S-SERVO II ST	S-SERVO II MINI
S-SERVO II 2X	S-SERVO II 3X		

Model	Unit	42			
		42S	42M	42L	42XL
Electromagnetic Brake	Form	Non-Excitation Type			
Input Voltage	V	24VDC			
Rated Current	A	0,2			
Power Consumption	W	5			
Friction Torque	N·m	0,2			

※ Electromagnetic brake will not be using for braking but for holding position when power-off.

● Torque Characteristics of Motor with Brake [42mm]

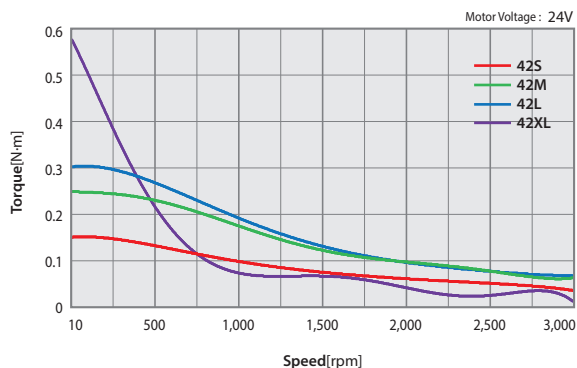
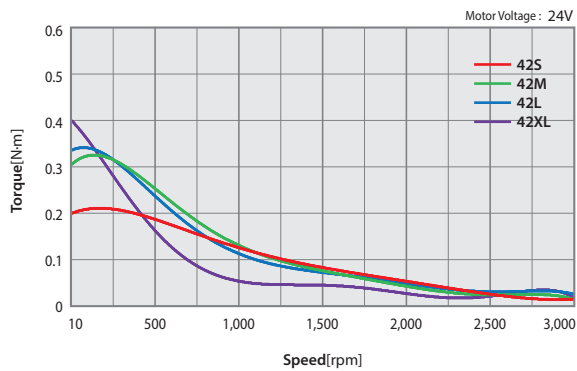
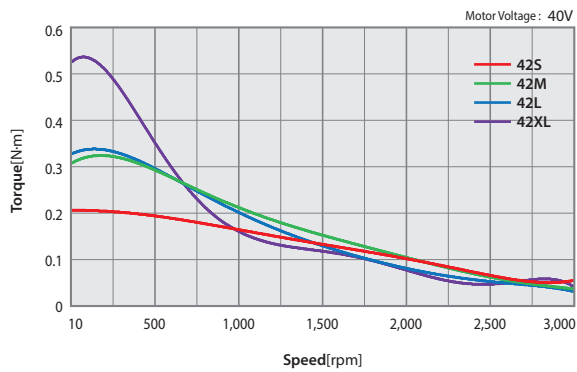

Applicable Model	
Ezi-SERVO ST	Ezi-SERVO Plus-R
Ezi-SERVO II EtherCAT	Ezi-SERVO II Plus-E
Ezi-SERVO II CC-Link	Ezi-STEP MPB
Ezi-STEP Plus-R	Ezi-STEP II EtherCAT
Ezi-STEP II Plus-E	Ezi-STEP II CC-Link

Applicable Model	
Ezi-SERVO MINI	Ezi-SERVO II BT
Ezi-SERVO Plus-R MINI	Ezi-SERVO ALL
Ezi-SERVO II EtherCAT MINI	Ezi-SERVO II EtherCAT 4X
Ezi-SERVO II EtherCAT ALL	Ezi-SERVO II Plus-E MINI
Ezi-SERVO II Plus-E ALL	Ezi-STEP MINI
Ezi-STEP BT	Ezi-STEP Plus-R MINI
Ezi-STEP ALL	Ezi-STEP II EtherCAT MINI
Ezi-STEP II EtherCAT 4X	Ezi-STEP II Plus-E MINI

Applicable Model	
S-SERVO II ST	S-SERVO II 2X
S-SERVO II 3X	S-SERVO II MINI

● Specifications of Brake [56mm]

Applicable Model			
Ezi-SERVO ST	Ezi-SERVO II BT	Ezi-SERVO Plus-R	Ezi-SERVO ALL
Ezi-SERVO II EtherCAT	Ezi-SERVO II EtherCAT MINI	Ezi-SERVO II EtherCAT 4X	Ezi-SERVO II EtherCAT ALL
Ezi-SERVO II Plus-E	Ezi-SERVO II Plus-E MINI	Ezi-SERVO II Plus-E ALL	Ezi-SERVO II CC-Link
Ezi-STEP MPB	Ezi-STEP BT	Ezi-STEP Plus-R	Ezi-STEP ALL
Ezi-STEP II EtherCAT	Ezi-STEP II EtherCAT MINI	Ezi-STEP II EtherCAT 4X	Ezi-STEP II Plus-E
Ezi-STEP II Plus-E MINI	Ezi-STEP II CC-Link	S-SERVO II ST	S-SERVO II 2X
S-SERVO II 3X			

Model	Unit	56		
		56S	56M	56L
Electromagnetic Brake	Form	Non-Excitation Type		
Input Voltage	V	24VDC \pm 10%		
Rated Current	A	0,27		
Power Consumption	W	6,6		
Friction Torque	N·m	0,7		

※ Electromagnetic brake will not be using for braking but for holding position when power-off.

● Torque Characteristics of Motor with Brake [56mm]

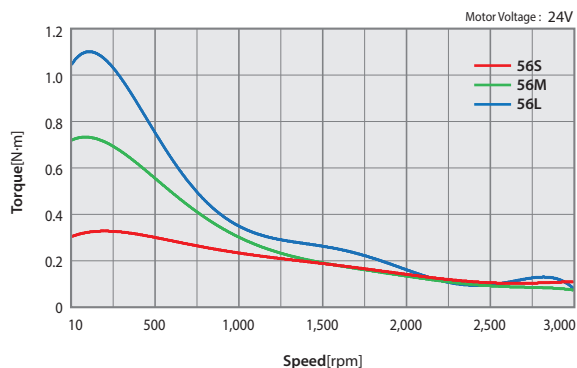
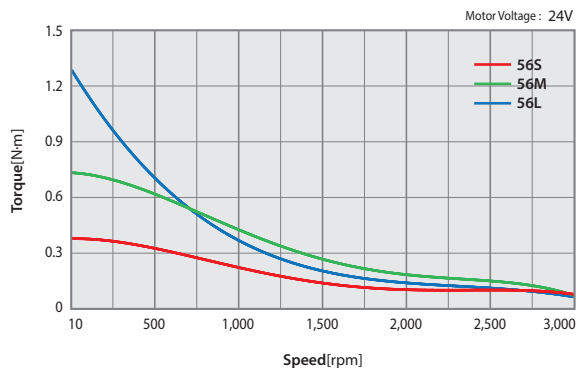
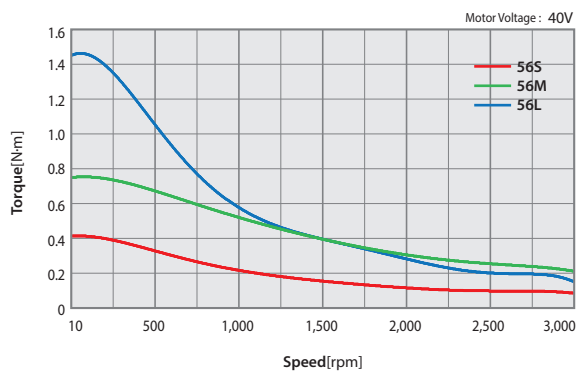

Applicable Model	
Ezi-SERVO ST	Ezi-SERVO Plus-R
Ezi-SERVO II EtherCAT	Ezi-SERVO II Plus-E
Ezi-SERVO II CC-Link	Ezi-STEP MPB
Ezi-STEP Plus-R	Ezi-STEP II EtherCAT
Ezi-STEP II Plus-E	Ezi-STEP II CC-Link

Applicable Model	
Ezi-SERVO II BT	Ezi-SERVO ALL
Ezi-SERVO II EtherCAT MINI	Ezi-SERVO II EtherCAT 4X
Ezi-SERVO II EtherCAT ALL	Ezi-SERVO II Plus-E MINI
Ezi-SERVO II Plus-E ALL	Ezi-STEP BT
Ezi-STEP ALL	Ezi-STEP II EtherCAT MINI
Ezi-STEP II EtherCAT 4X	Ezi-STEP II Plus-E MINI

Applicable Model	
S-SERVO II ST	S-SERVO II 2X
S-SERVO II 3X	

● Specifications of Brake [60mm]

Applicable Model			
Ezi-SERVO ST	Ezi-SERVO Plus-R	Ezi-SERVO II BT	Ezi-SERVO ALL
Ezi-SERVO II EtherCAT	Ezi-SERVO II EtherCAT MINI	Ezi-SERVO II EtherCAT 4X	Ezi-SERVO II EtherCAT ALL
Ezi-SERVO II Plus-E	Ezi-SERVO II Plus-E MINI	Ezi-SERVO II Plus-E ALL	Ezi-SERVO II CC-Link
Ezi-STEP MPB	Ezi-STEP Plus-R	Ezi-STEP II EtherCAT	Ezi-STEP II EtherCAT MIMI
Ezi-STEP II EtherCAT 4X	Ezi-STEP II Plus-E	Ezi-STEP II Plus-E MINI	Ezi-STEP II CC-Link
S-SERVO II ST	S-SERVO II 2X	S-SERVO II 3X	

Model	Unit	60		
		60S	60M	60L
Electromagnetic Brake	Form	Non-Excitation Type		
Input Voltage	V	24VDC		
Rated Current	A	0.27		
Power Consumption	W	6.6		
Friction Torque	N·m	0.7		

※ Electromagnetic brake will not be using for braking but for holding position when power-off.

● Torque Characteristics of Motor with Brake [60mm]

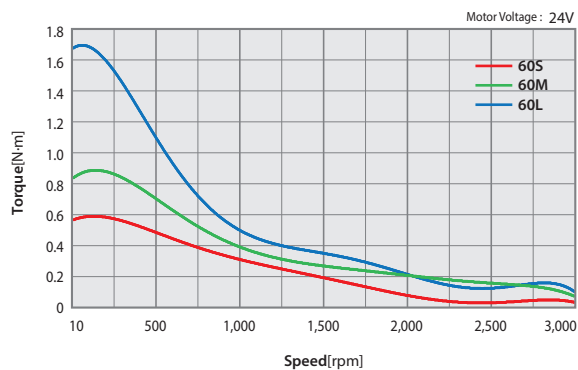
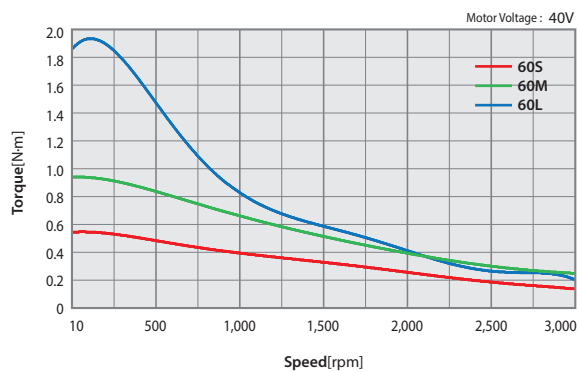

Applicable Model	
Ezi-SERVO ST	Ezi-SERVO Plus-R
Ezi-SERVO II EtherCAT	Ezi-SERVO II Plus-E
Ezi-SERVO II CC-Link	Ezi-STEP MPB
Ezi-STEP Plus-R	Ezi-SERVO ALL
Ezi-STEP II EtherCAT	Ezi-STEP II Plus-E
Ezi-STEP II CC-Link	

Applicable Model	
Ezi-SERVO II BT	Ezi-SERVO II EtherCAT MINI
Ezi-SERVO II EtherCAT 4X	Ezi-SERVO II EtherCAT ALL
Ezi-SERVO II Plus-E MINI	Ezi-SERVO II Plus-E ALL
S-SERVO II ST	S-SERVO II 2X
S-SERVO II 3X	Ezi-STEP II EtherCAT MINI
Ezi-STEP II EtherCAT 4X	

● Specifications of Brake [86mm]

Applicable Model			
Ezi-SERVO ST	Ezi-SERVO Plus-R	Ezi-SERVO II EtherCAT	Ezi-SERVO II EtherCAT ALL
Ezi-SERVO II Plus-E	Ezi-SERVO II Plus-E ALL	Ezi-SERVO II CC-Link	Ezi-STEP HPB
Ezi-STEP BT	Ezi-STEP Plus-R	Ezi-STEP II EtherCAT	Ezi-STEP II Plus-E
Ezi-STEP II CC-Link			

Model	Unit	86		
		86M	86L	86XL
Electromagnetic Brake	Form	Non-Excitation Type		
Input Voltage	V	24VDC		
Rated Current	A	0,54		
Power Consumption	W	13,0		
Friction Torque	N·m	4,0		

※ Electromagnetic brake will not be using for braking but for holding position when power-off.

● Torque Characteristics of Motor with Brake [86mm]

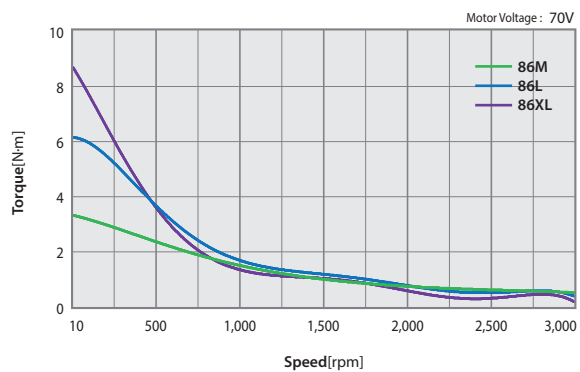

Applicable Model	
Ezi-SERVO ST	Ezi-SERVO Plus-R
Ezi-SERVO II EtherCAT	Ezi-SERVO II EtherCAT ALL
Ezi-SERVO II Plus-E	Ezi-SERVO II Plus-E ALL
Ezi-SERVO II CC-Link	Ezi-STEP HPB
Ezi-STEP BT	Ezi-STEP Plus-R
Ezi-STEP II EtherCAT	Ezi-STEP II Plus-E
Ezi-STEP II CC-Link	

● Dimensions of Motor with Brake [42mm]

Applicable Model

Ezi-SERVO ST	Ezi-SERVO MINI	Ezi-SERVO Plus-R	Ezi-SERVO Plus-R MINI
--------------	----------------	------------------	-----------------------

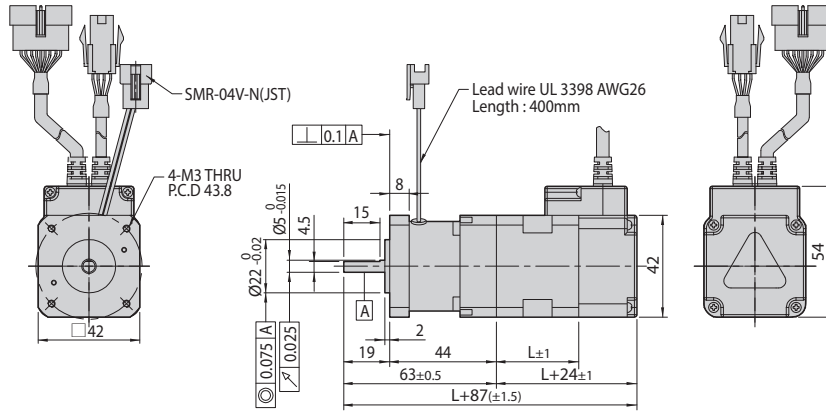

42mm

Model Name	Length(L)	Weight(kg)
EzM-42S	34	0.56
EzM-42M	40	0.62
EzM-42L	48	0.69
EzM-42XL	60	0.83

Applicable Model

Ezi-SERVO II BT		
-----------------	--	--

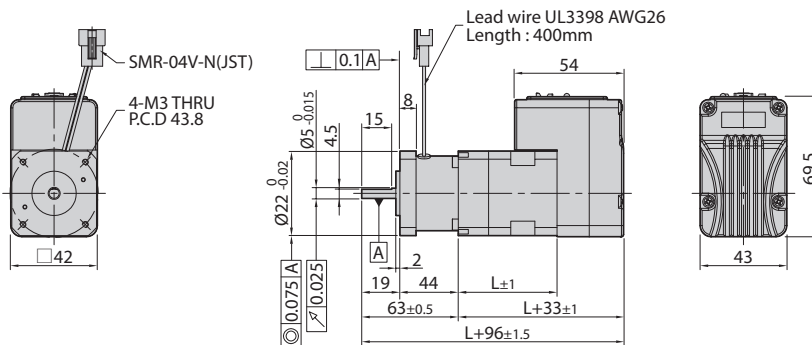

42mm

Model Name	Length(L)	Weight(kg)
42S	34	0.68
42M	40	0.77
42L	48	0.84
42XL	60	0.95

Applicable Model

Ezi-SERVO ALL		
---------------	--	--

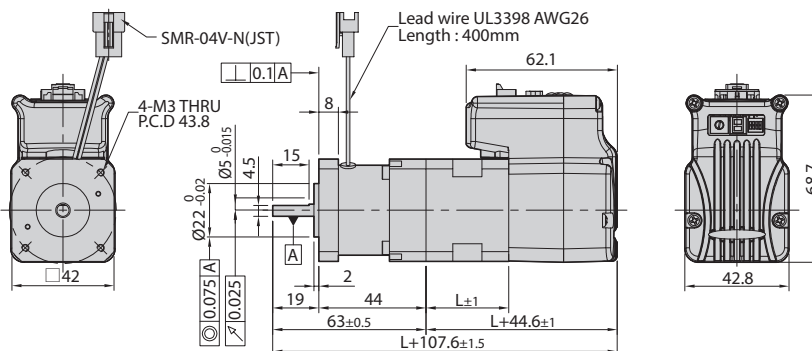

42mm

Model Name	Length(L)	Weight(kg)
42S	34	0.67
42M	40	0.77
42L	48	0.84
42XL	60	0.95

● Dimensions of Motor with Brake [42mm]

Applicable Model			
Ezi-SERVO II EtherCAT	Ezi-SERVO II EtherCAT MINI	Ezi-SERVO II EtherCAT 4X	Ezi-SERVO II Plus-E
Ezi-SERVO II Plus-E MINI	Ezi-SERVO II CC-Link		

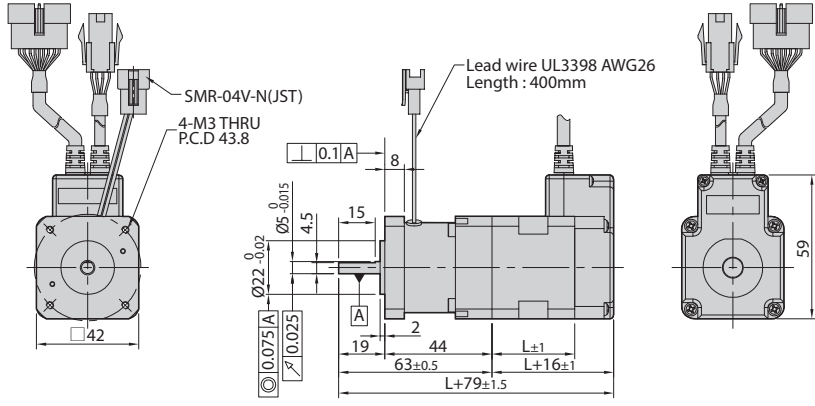

42mm

Model Name	Length(L)	Weight(kg)
EzM2-42S	34	0.55
EzM2-42M	40	0.62
EzM2-42L	48	0.69
EzM2-42XL	60	0.82

Applicable Model			
Ezi-SERVO II EtherCAT ALL			

◆ M Connector Type

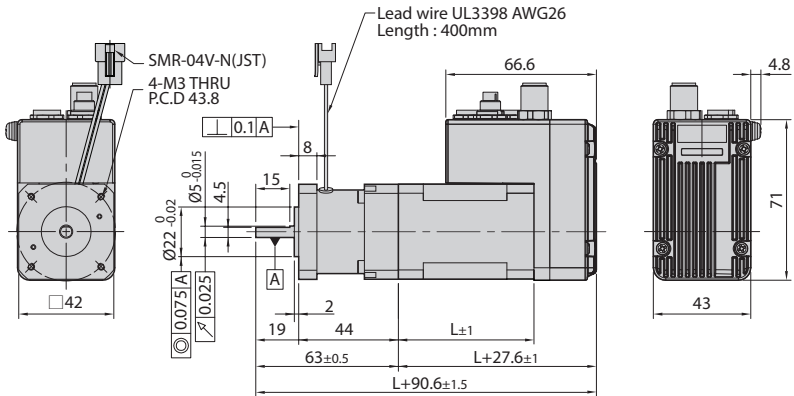

42mm

Model Name	Length(L)	Weight(kg)
42M	40	0.70
42L	48	0.78
42XL	60	0.92

◆ RJ45 Connector Type

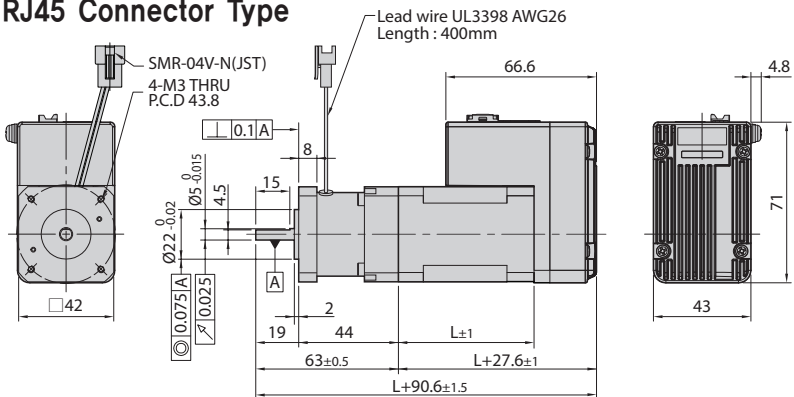

● Dimensions of Motor with Brake [42mm]

Applicable Model

Ezi-SERVO II Plus-E ALL

◆ M Connector Type

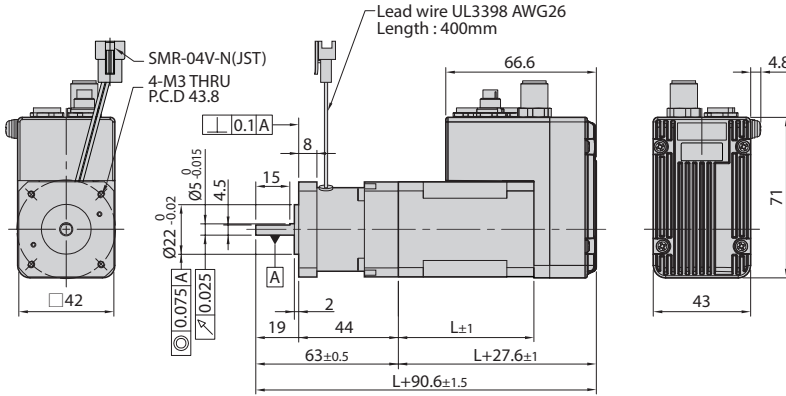

42mm

Model Name	Length(L)	Weight(kg)
42M	40	0.70
42L	48	0.78
42XL	60	0.92

◆ RJ45 Connector Type

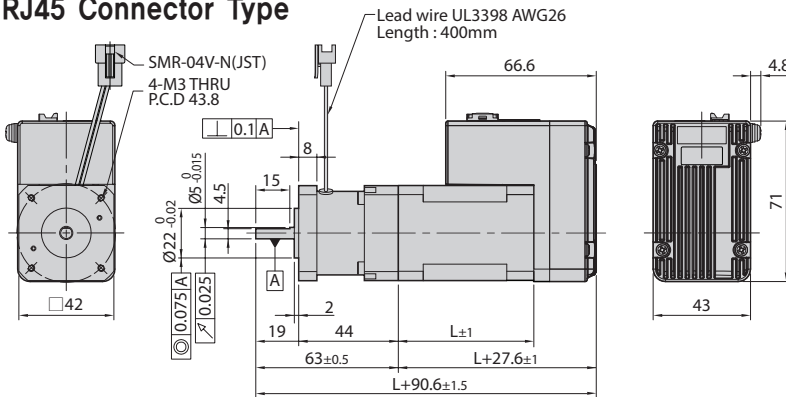

● Dimensions of Motor with Brake [42mm]

Applicable Model			
S-SERVO II ST	S-SERVO II MINI	S-SERVO II 2X	S-SERVO II 3X

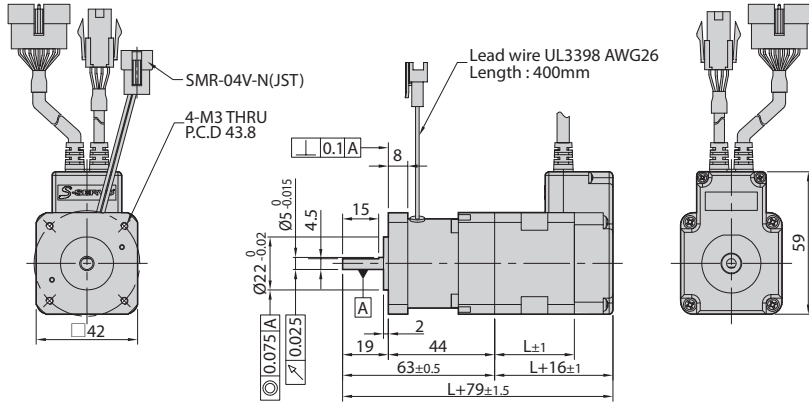

42mm

Model Name	Length(L)	Weight(kg)
SM-42S	33	0.54
SM-42M	39	0.60
SM-42L	47	0.68
SM-42XL	60	0.83

Applicable Model			
Ezi-STEP ST	Ezi-STEP MINI	Ezi-STEP Plus-R	Ezi-STEP Plus-R MINI
Ezi-STEP II EtherCAT	Ezi-STEP II EtherCAT MINI	Ezi-STEP II EtherCAT 4X	Ezi-STEP II Plus-E
Ezi-STEP II Plus-E MINI	Ezi-STEP II CC-Link		

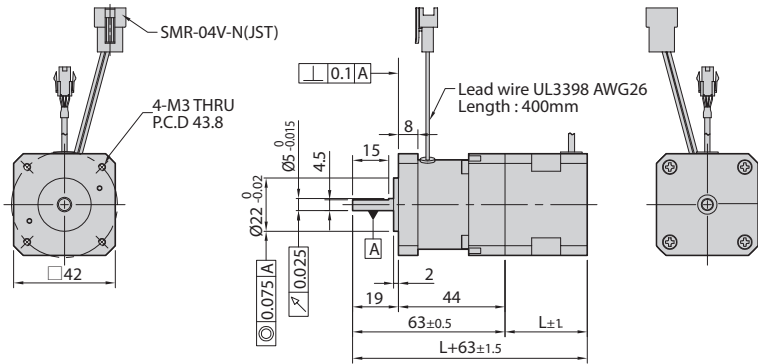

42mm

Model Name	Length(L)	Weight(kg)
BM-42S	34	0.50
BM-42M	40	0.56
BM-42L	48	0.63
BM-42XL	60	0.77

Applicable Model			
Ezi-STEP BT			

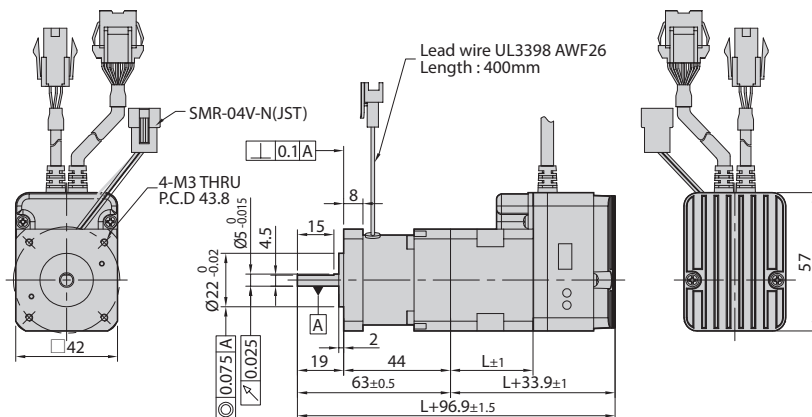

42mm

Model Name	Length(L)	Weight(kg)
42S	34	0.56
42M	40	0.63
42L	48	0.70
42XL	60	0.82

● Dimensions of Motor with Brake [42mm]

Applicable Model

Ezi-STEP ALL

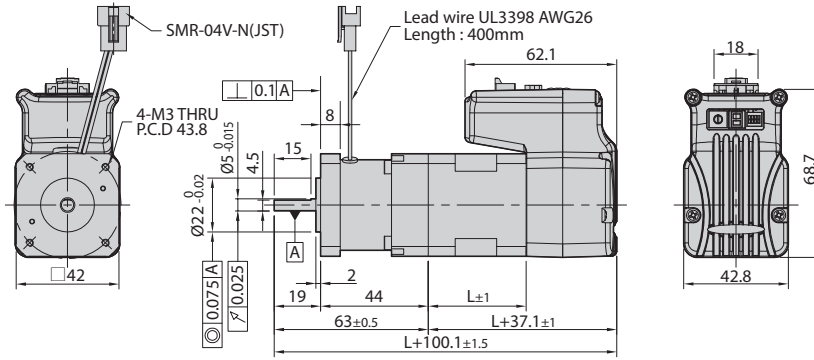

42mm

Model Name	Length(L)	Weight(kg)
42S	34	0.56
42M	40	0.63
42L	48	0.69
42XL	60	0.82

● Dimensions of Motor with Brake [56mm]

Applicable Model			
Ezi-SERVO ST	Ezi-SERVO Plus-R		

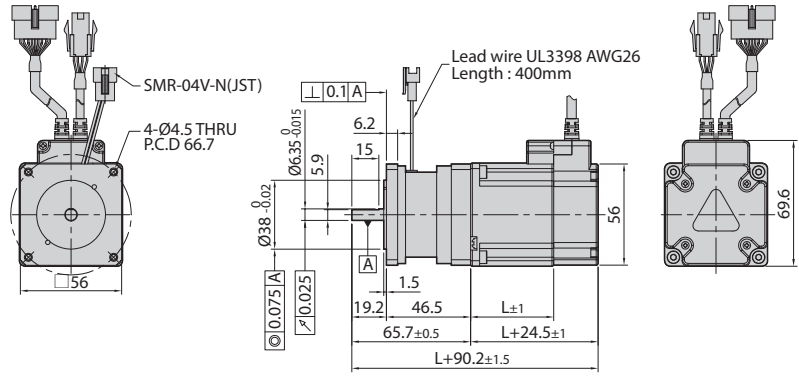

56mm

Model Name	Length(L)	Weight(kg)
EzM-56S	46	1.03
EzM-56M	55	1.20
EzM-56L	80	1.65

Applicable Model			
Ezi-SERVO II BT			

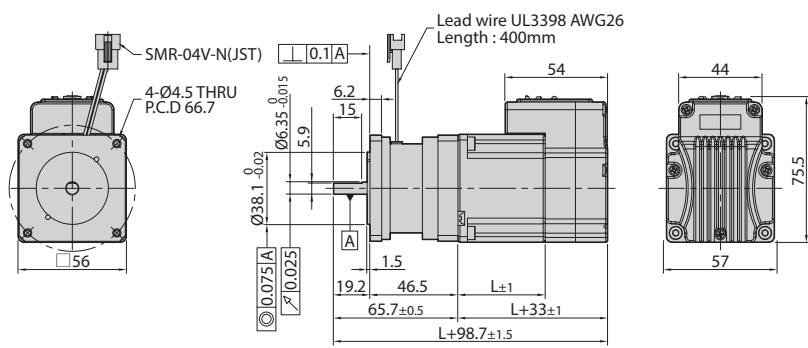

56mm

Model Name	Length(L)	Weight(kg)
56S	46	1.26
56M	55	1.36
56L	80	1.89

Applicable Model			
Ezi-SERVO ALL			

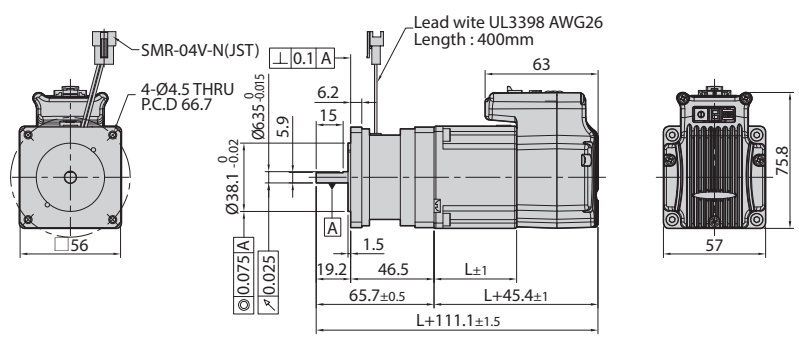

56mm

Model Name	Length(L)	Weight(kg)
56S	46	1.26
56M	55	1.36
56L	80	1.89

● Dimensions of Motor with Brake [56mm]

Applicable Model			
Ezi-SERVO II EtherCAT	Ezi-SERVO II EtherCAT MINI	Ezi-SERVO II EtherCAT 4X	Ezi-SERVO II Plus-E
Ezi-SERVO II Plus-E MINI	Ezi-SERVO II CC-Link		

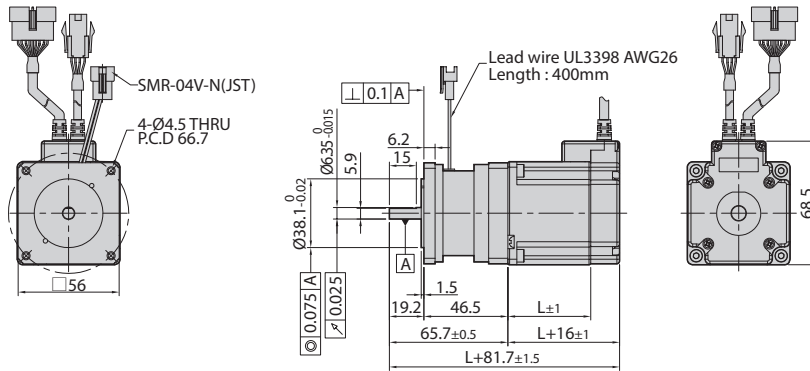

56mm

Model Name	Length(L)	Weight(kg)
EzM2-56S	46	1,03
EzM2-56M	55	1,20
EzM2-56L	80	1,65

Applicable Model			
Ezi-SERVO II EtherCAT ALL			

◆ M Connector Type

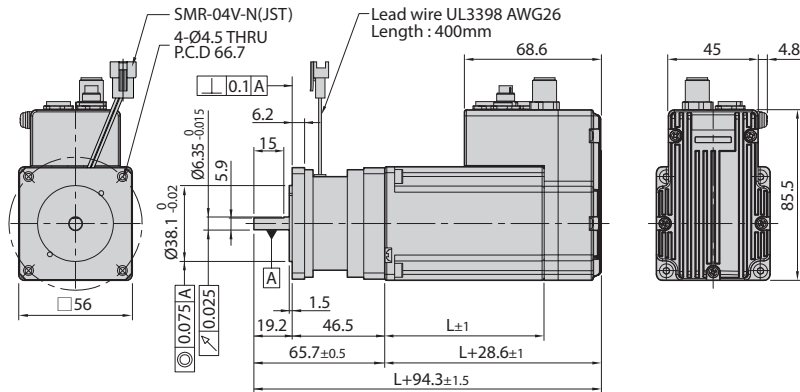

56mm

Model Name	Length(L)	Weight(kg)
56S	46	1,18
56M	55	1,34
56L	80	1,78

◆ RJ45 Connector Type

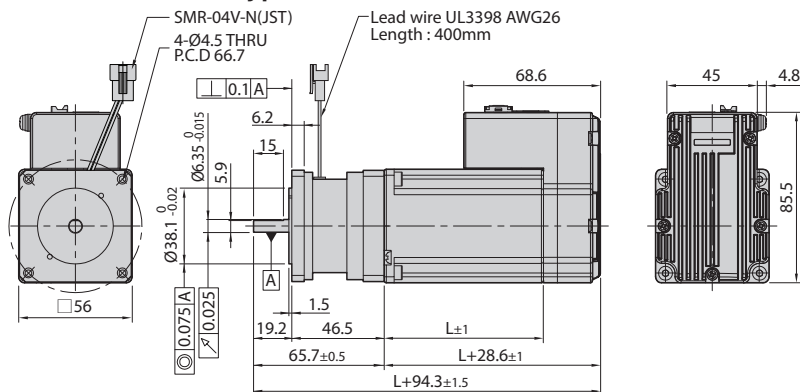

● Dimensions of Motor with Brake [56mm]

Applicable Model			
Ezi-SERVO II Plus-E ALL			

◆ M Connector Type

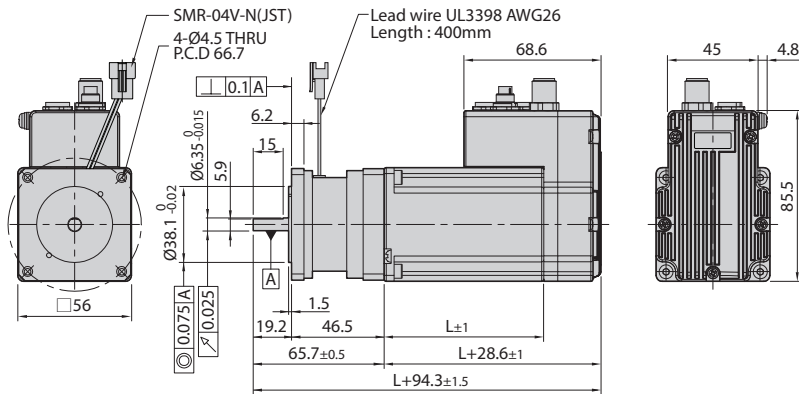

56mm

Model Name	Length(L)	Weight(kg)
56S	46	1,18
56M	55	1,34
56L	80	1,78

◆ RJ45 Connector Type

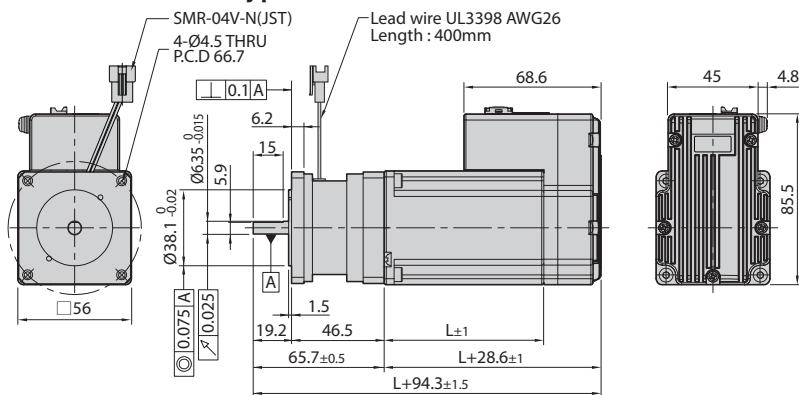

● Dimensions of Motor with Brake [56mm]

Applicable Model

S-SERVO II	S-SERVO II 2X	S-SERVO II 3X	
------------	---------------	---------------	--

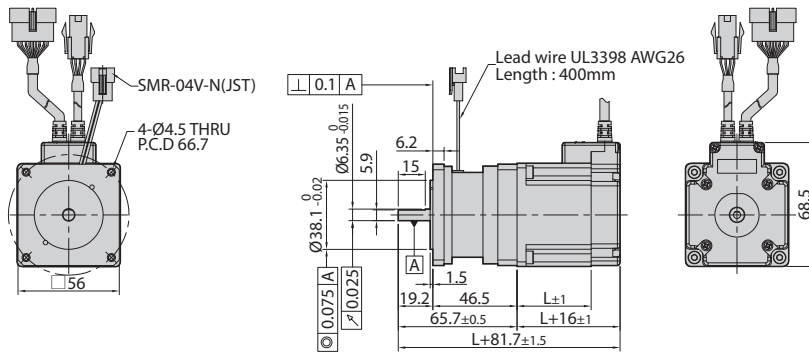

56mm

Model Name	Length(L)	Weight(kg)
SM-56S	41	0,93
SM-56M	56	1,16
SM-56L	76	1,50

Applicable Model

Ezi-STEP ST	Ezi-STEP Plus-R	Ezi-STEP II EtherCAT	Ezi-STEP II EtherCAT MINI
Ezi-STEP II EtherCAT 4X	Ezi-STEP II Plus-E	Ezi-STEP II Plus-E MINI	Ezi-STEP II CC-Link

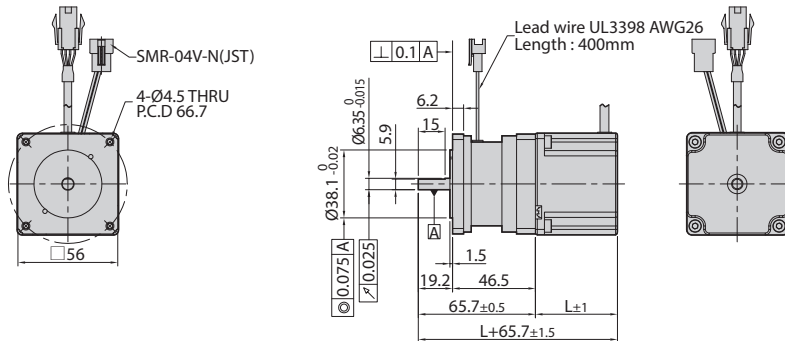

56mm

Model Name	Length(L)	Weight(kg)
BM-56S	46	0,97
BM-56M	55	1,15
BM-56L	80	1,58

Applicable Model

Ezi-STEP BT			
-------------	--	--	--

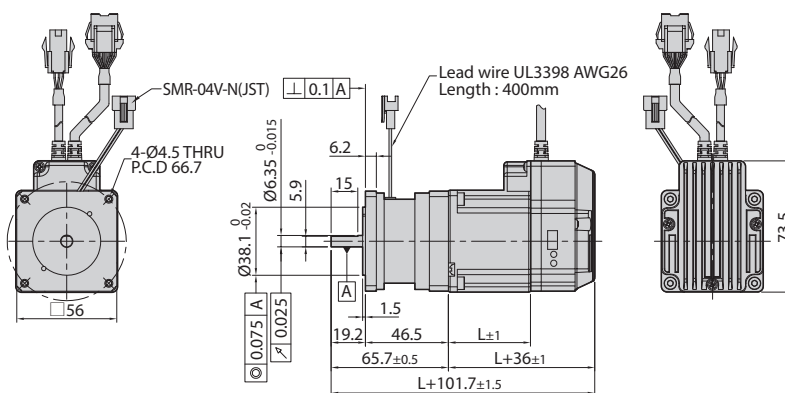

56mm

Model Name	Length(L)	Weight(kg)
56S	46	1,11
56M	55	1,27
56L	80	1,70

● Dimensions of Motor with Brake [56mm]

Applicable Model			
Ezi-STEP ALL			

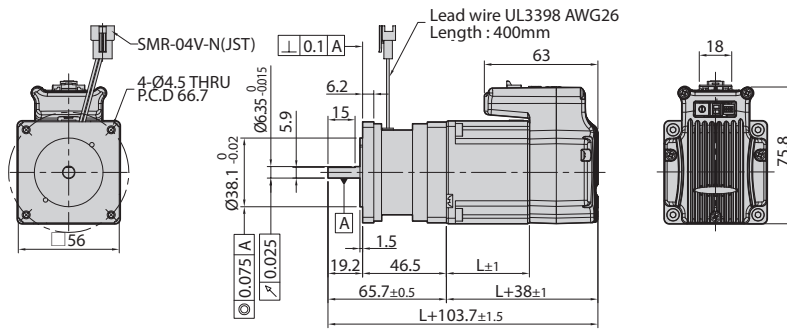

56mm

Model Name	Length(L)	Weight(kg)
56S	46	1.09
56M	55	1.25
56L	80	1.69

Option

Brake

Gearbox

● Dimensions of Motor with Brake [60mm]

Applicable Model

Ezi-SERVO ST

Ezi-SERVO Plus-R

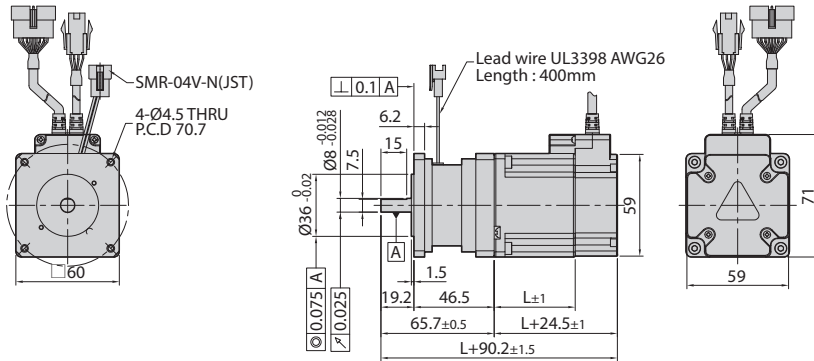

60mm

Model Name	Length(L)	Weight(kg)
EzM-60S	47	1,14
EzM-60M	56	1,30
EzM-60L	85	1,86

Applicable Model

Ezi-SERVO II BT

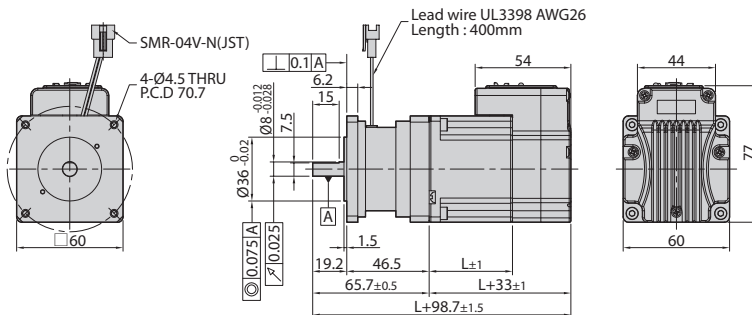

60mm

Model Name	Length(L)	Weight(kg)
60S	47	1,55
60M	56	1,52
60L	85	2,38

Applicable Model

Ezi-SERVO ALL

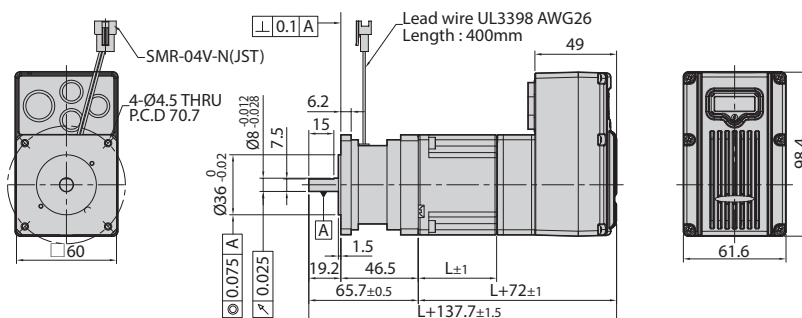

60mm

Model Name	Length(L)	Weight(kg)
60L	85	2,54

● Dimensions of Motor with Brake [60mm]

Applicable Model

Ezi-SERVO ALL ABS

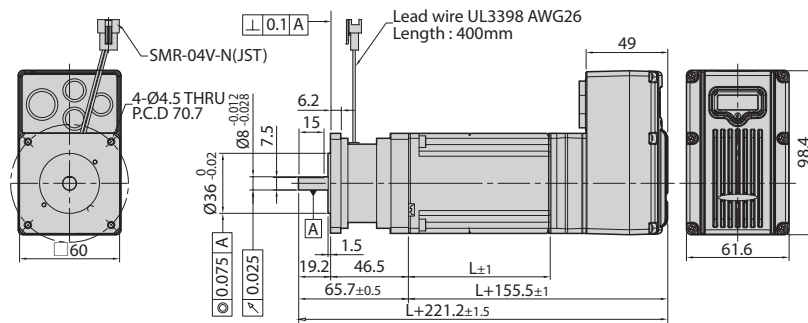

60mm

Model Name	Length(L)	Weight(kg)
60L-ABS	85	2.54

Applicable Model

Ezi-SERVO II EtherCAT

Ezi-SERVO II EtherCAT MINI

Ezi-SERVO II EtherCAT 4X

Ezi-SERVO II Plus-E

Ezi-SERVO II Plus-E MINI

Ezi-SERVO II CC-Link

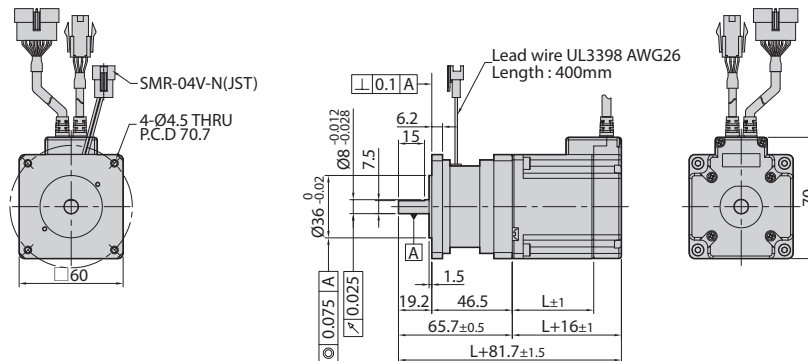

60mm

Model Name	Length(L)	Weight(kg)
EzM2-60S	47	1.11
EzM2-60M	56	1.30
EzM2-60L	85	1.86

● Dimensions of Motor with Brake [60mm]

Applicable Model

Ezi-SERVO II EtherCAT ALL

◆ M Connector Type

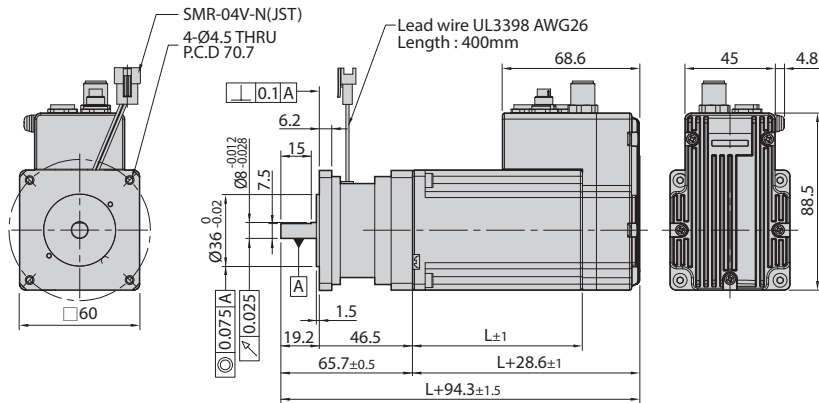

60mm

Model Name	Length(L)	Weight(kg)
60S	47	1,28
60M	56	1,42
60L	85	1,98

◆ RJ45 Connector Type

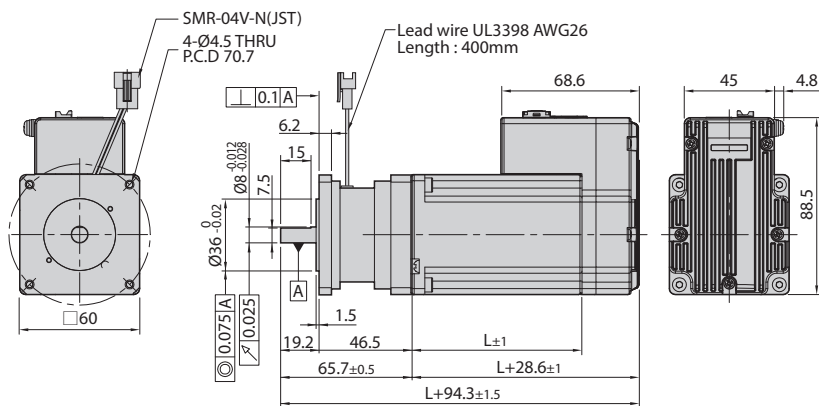

● Dimensions of Motor with Brake [60mm]

Applicable Model

Ezi-SERVO II Plus-E ALL

◆ M Connector Type

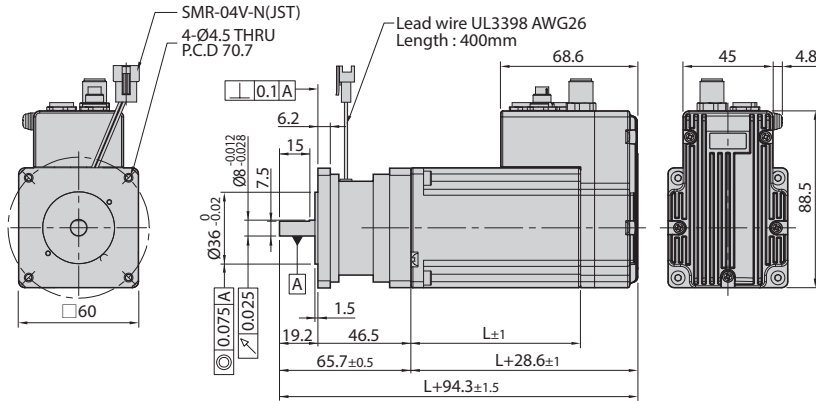

60_{mm}

Model Name	Length(L)	Weight(kg)
60S	47	1,28
60M	56	1,42
60L	85	1,98

◆ RJ45 Connector Type

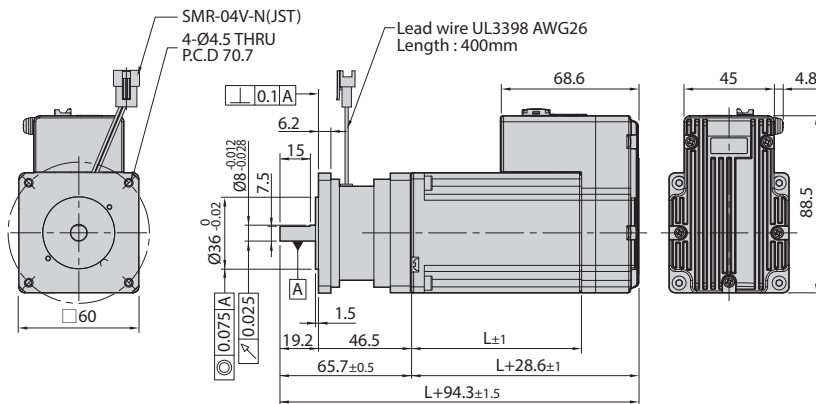

● Dimensions of Motor with Brake [60mm]

Applicable Model

S-SERVO II	S-SERVO II 2X	S-SERVO II 3X	
------------	---------------	---------------	--

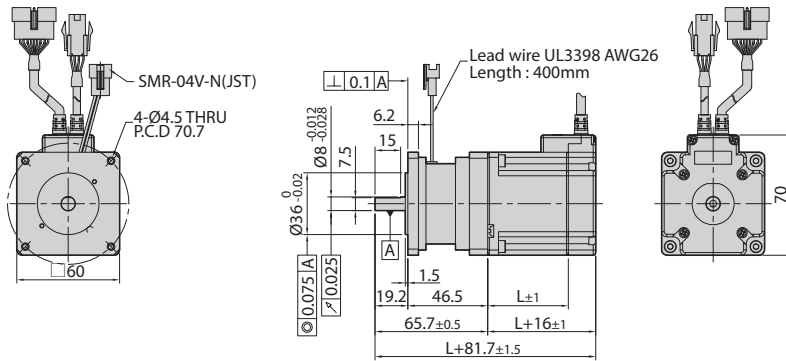

60mm

Model Name	Length(L)	Weight(kg)
SM-60S	47	1,14
SM-60M	56	1,30
SM-60L	85	1,86

Applicable Model

Ezi-STEP ST	Ezi-STEP Plus-R	Ezi-STEP II EtherCAT	Ezi-STEP II EtherCAT MINI
Ezi-STEP II EtherCAT 4X	Ezi-STEP II Plus-E	Ezi-STEP II Plus-E MINI	Ezi-STEP II CC-Link

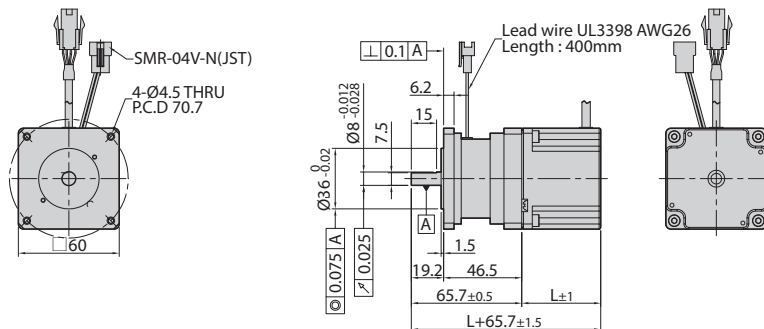

60mm

Model Name	Length(L)	Weight(kg)
BM-60S	47	1,06
BM-60M	56	1,23
BM-60L	85	1,79

◆ Dimensions of Motor with Brake [86mm]

Applicable Model

Ezi-SERVO ST	Ezi-SERVO Plus-R		
--------------	------------------	--	--

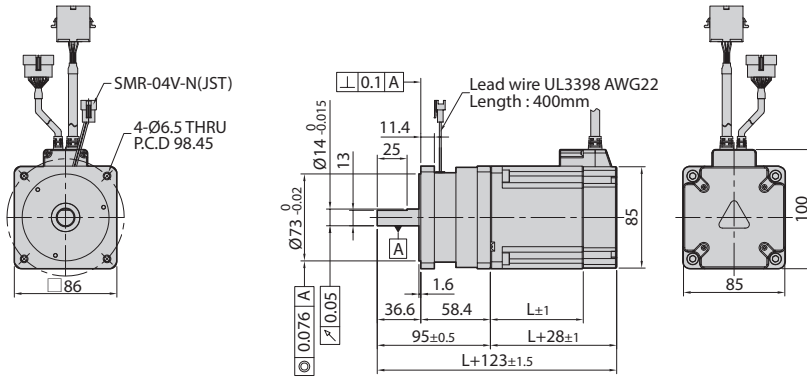

86mm

Model Name	Length(L)	Weight(kg)
EzM-86M	78	3,71
EzM-86L	117	5,26
EzM-86XL	155	6,79

Applicable Model

Ezi-SERVO II EtherCAT	Ezi-SERVO II Plus-E	Ezi-SERVO II CC-Link	
-----------------------	---------------------	----------------------	--

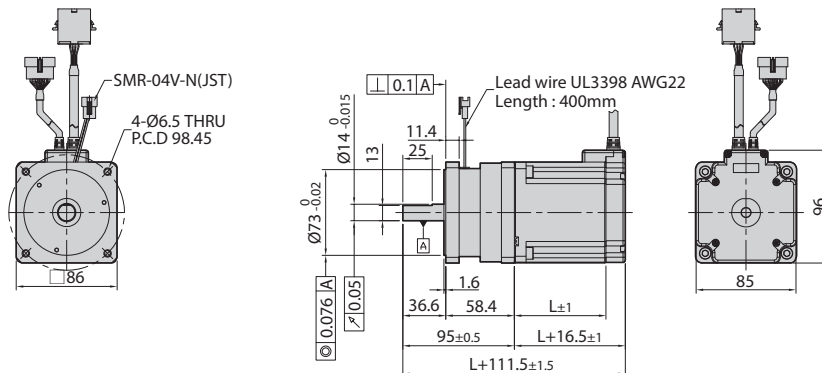

86mm

Model Name	Length(L)	Weight(kg)
EzM2-86M	78	3,66
EzM2-86L	117	5,24
EzM2-86XL	155	6,75

Applicable Model

Ezi-SERVO II EtherCAT ALL			
---------------------------	--	--	--

◆ M Connector Type

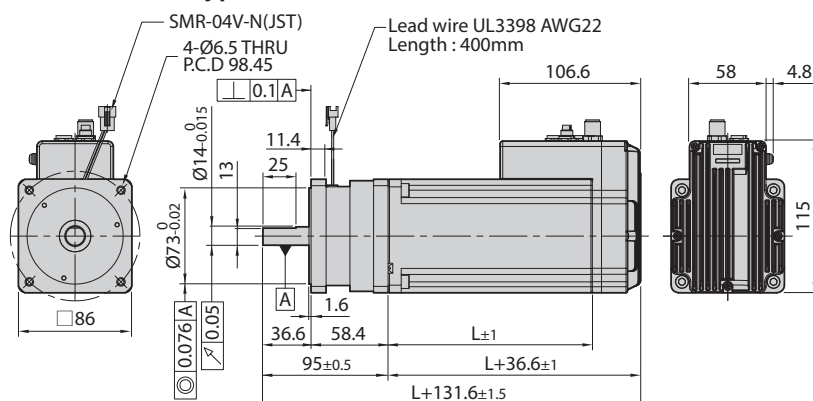

86mm

Model Name	Length(L)	Weight(kg)
86M	78	3,98
86L	117	5,53
86XL	155	7,06

● Dimensions of Motor with Brake [86mm]

Applicable Model

Ezi-SERVO II EtherCAT ALL

◆ RJ45 Connector Type

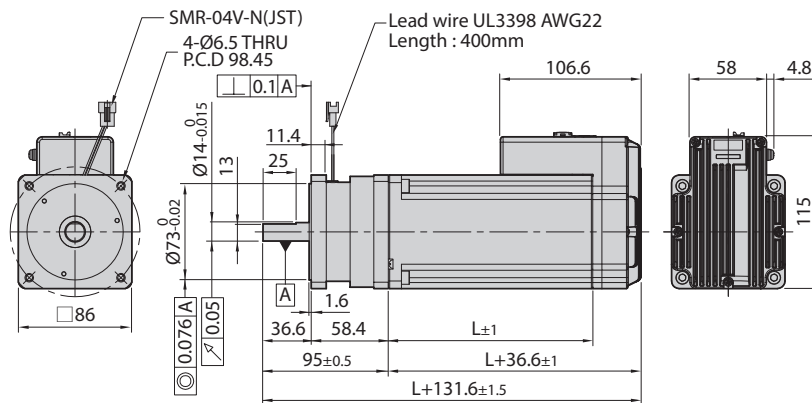

86mm

Model Name	Length(L)	Weight(kg)
86M	78	3,98
86L	117	5,53
86XL	155	7,06

Applicable Model

Ezi-SERVO II Plus-E ALL

◆ M Connector Type

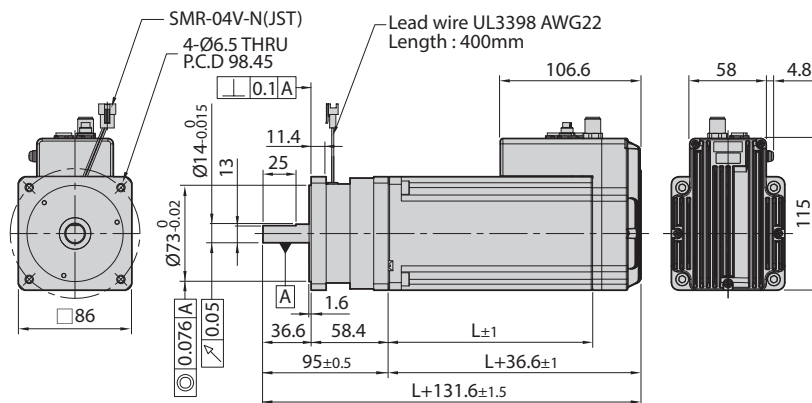

86mm

Model Name	Length(L)	Weight(kg)
86M	78	3,98
86L	117	5,53
86XL	155	7,06

◆ RJ45 Connector Type

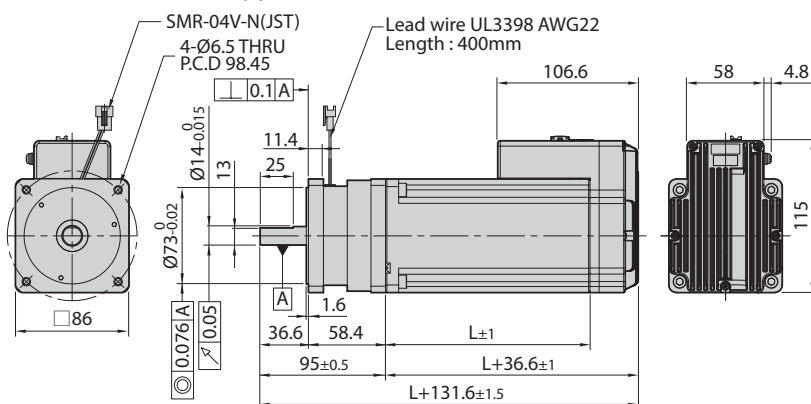

● Dimensions of Motor with Brake [86mm]

Applicable Model			
Ezi-STEP ST	Ezi-STEP Plus-R	Ezi-STEP II EtherCAT	Ezi-STEP II Plus-E
Ezi-STEP II CC-Link			

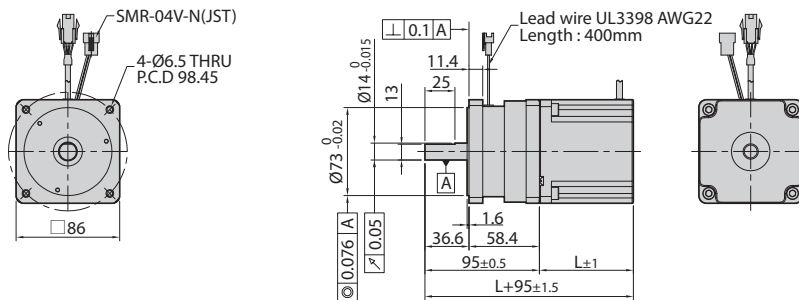

86mm

Model Name	Length(L)	Weight(kg)
BM-86M	78	3.58
BM-86L	117	5.11
BM-86XL	155	6.63

Applicable Model			
Ezi-STEP BT			

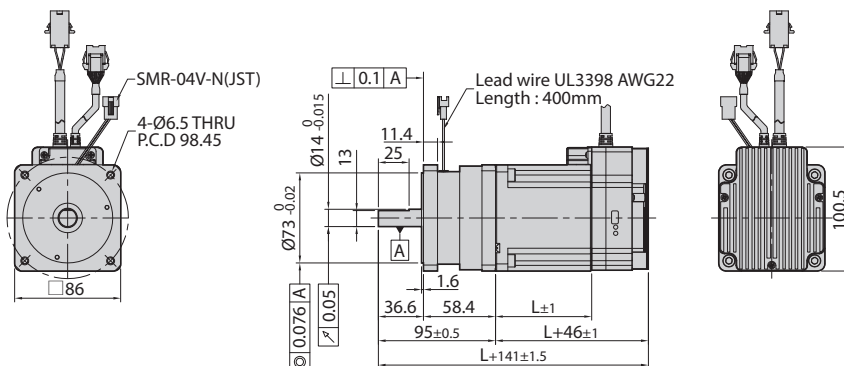

86mm

Model Name	Length(L)	Weight(kg)
86M	78	3.75
86L	117	5.25
86XL	155	6.75

● Electrical Brake and Power Connection

Ezi-SERVO ST

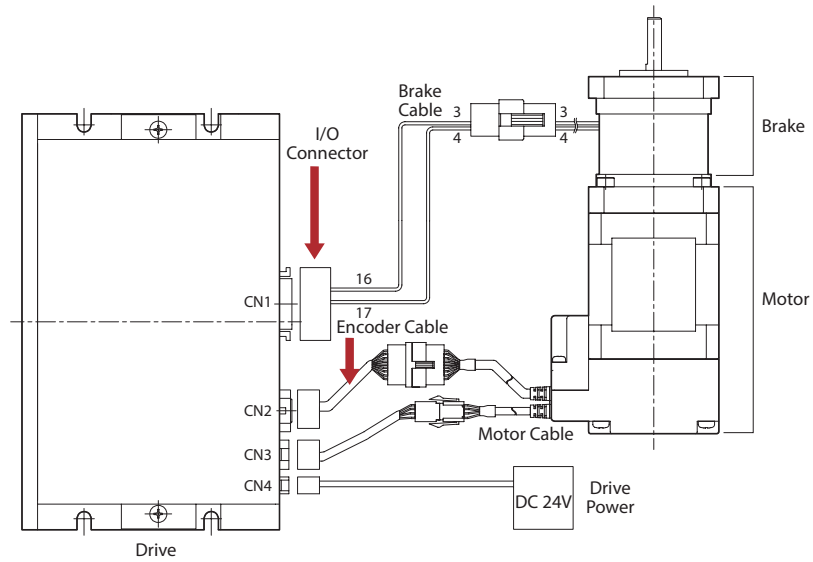

Ezi-SERVO ST_ 86mm

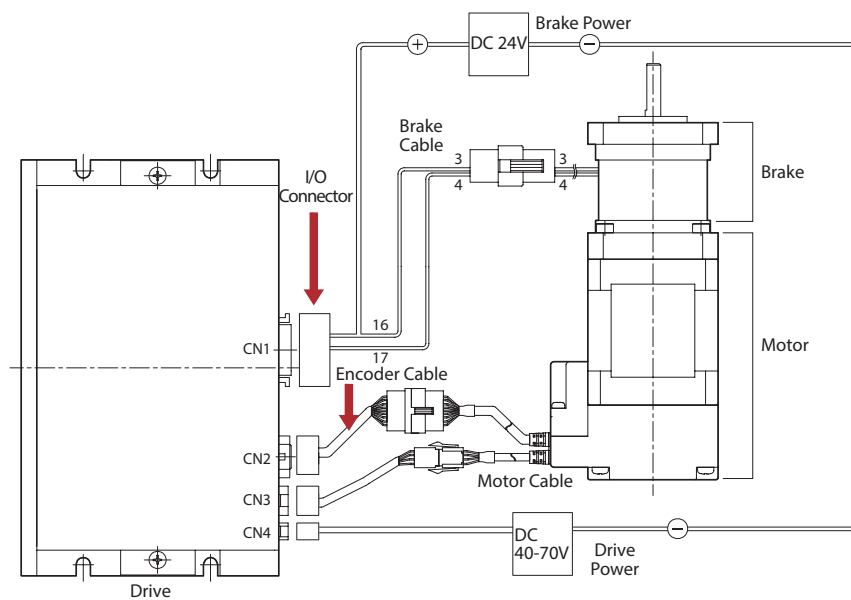

● Electrical Brake and Power Connection

Ezi-SERVO MINI / S-SERVOII MINI

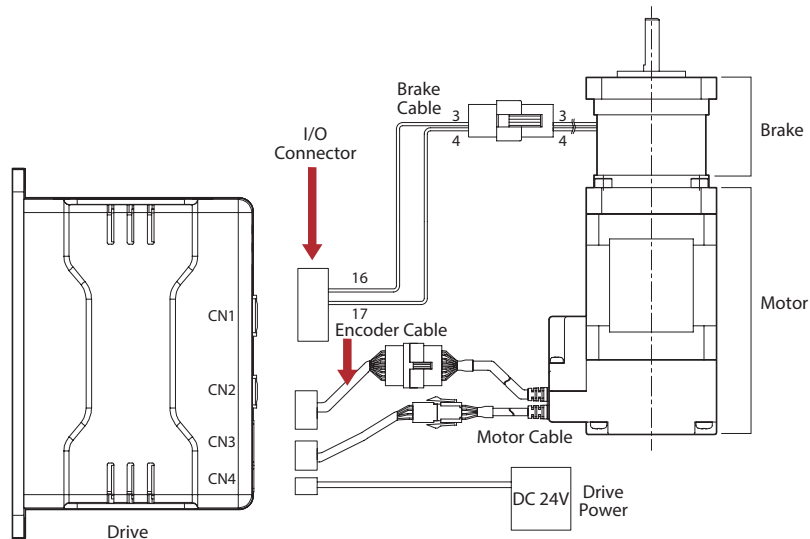

Ezi-SERVO Plus-R / Ezi-SERVOII Plus-E, Ezi-SERVOII Plus-E_ 86mm

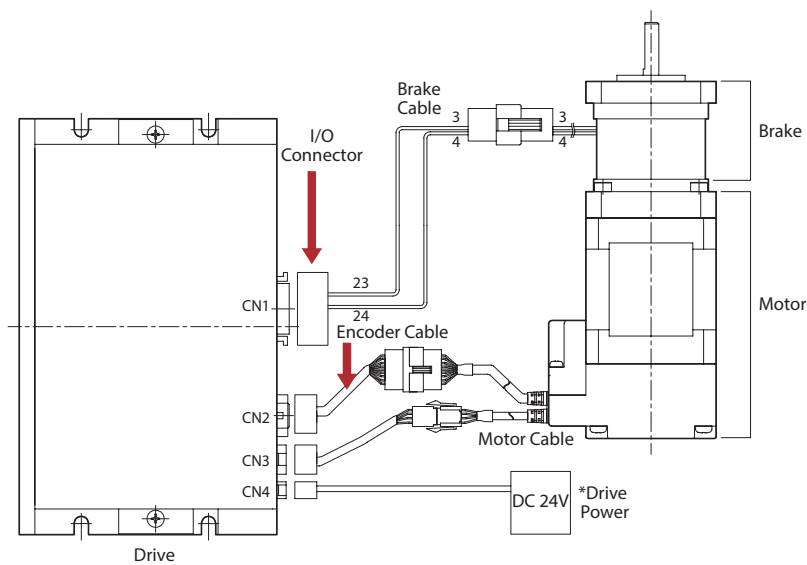

* In case of Ezi-SERVOII Plus-E 86mm, the voltage of power supply is DC40~70V.

● Electrical Brake and Power Connection

Ezi-SERVO Plus-R_ 86mm

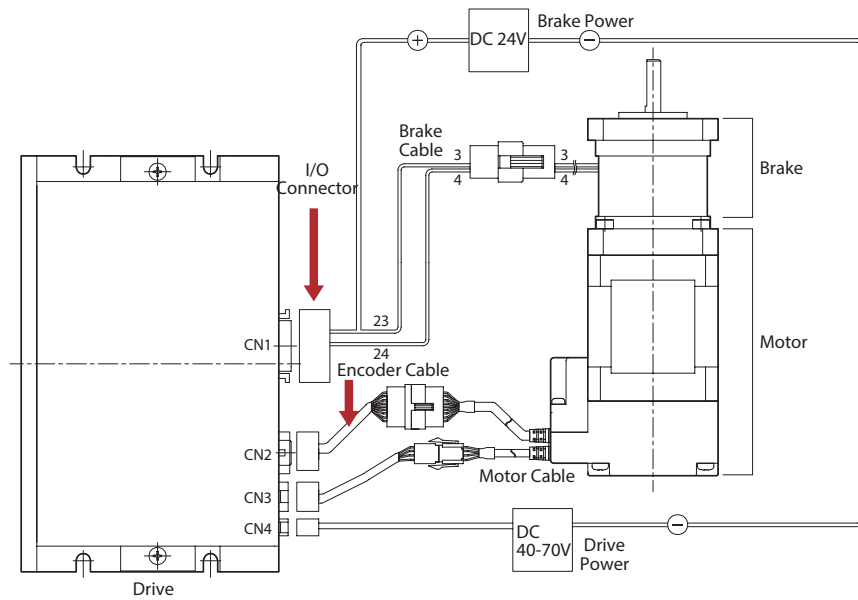

Ezi-SERVO Plus-R MINI

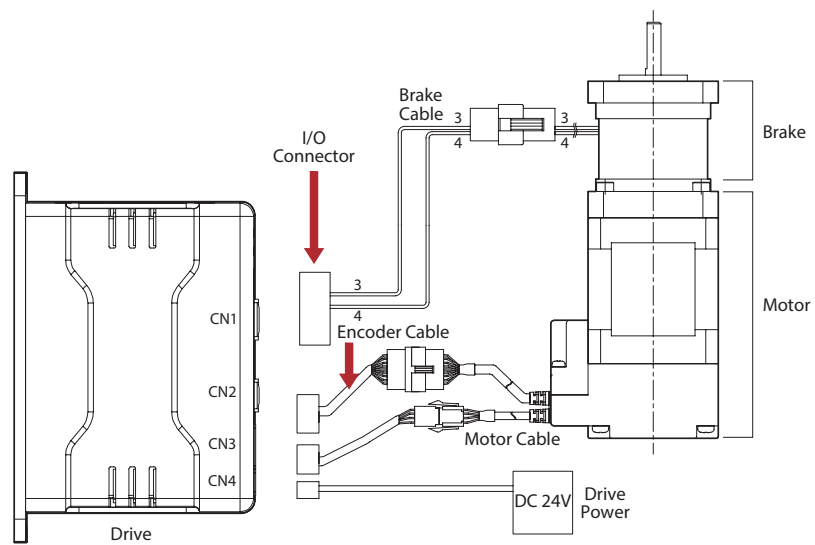

● Electrical Brake and Power Connection

Ezi-SERVOII BT

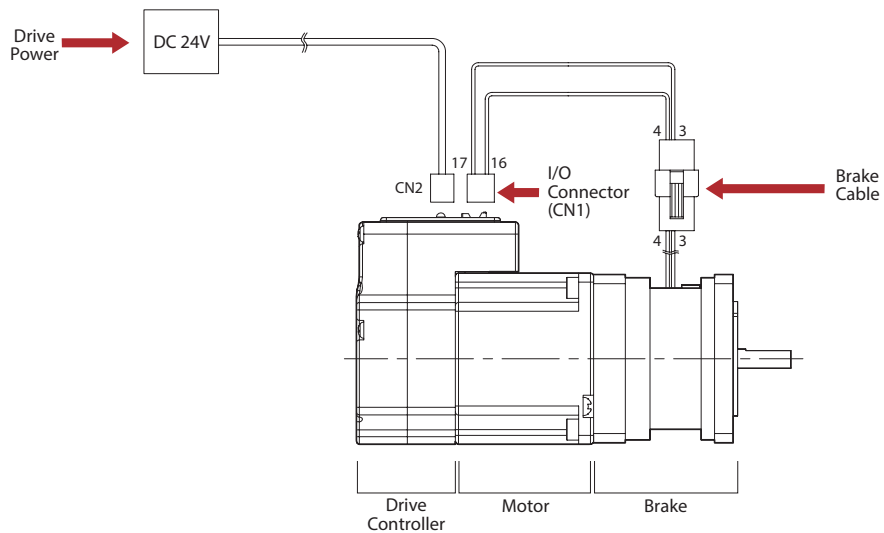

Ezi-SERVOII EtherCAT, Ezi-SERVOII CC-Link

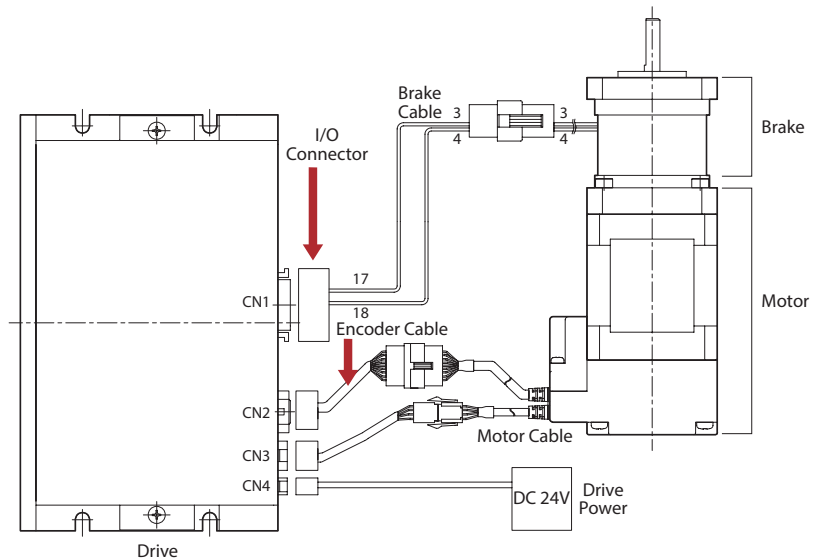

Option

Brake

Gearbox

● Electrical Brake and Power Connection

Ezi-SERVOII EtherCAT_ 86mm, Ezi-SERVOII CC-Link_ 86mm

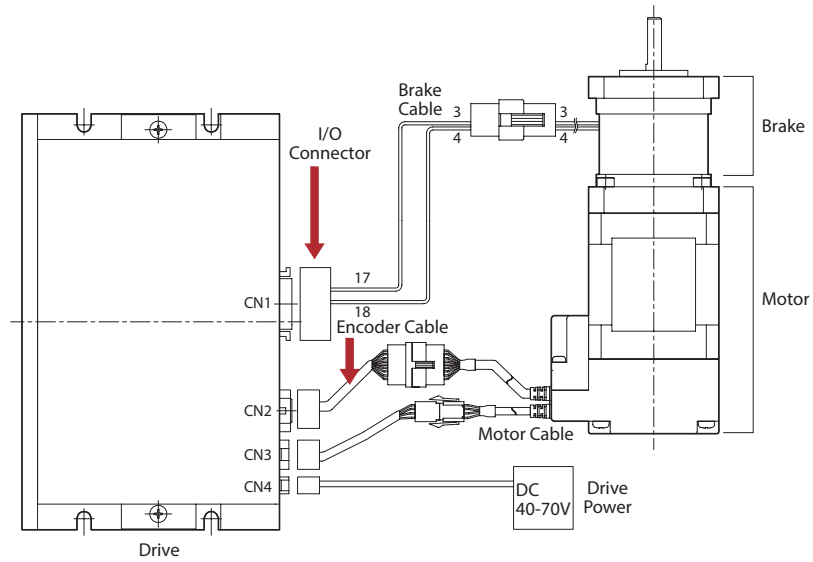

Ezi-SERVOII EtherCAT 4X, 3X

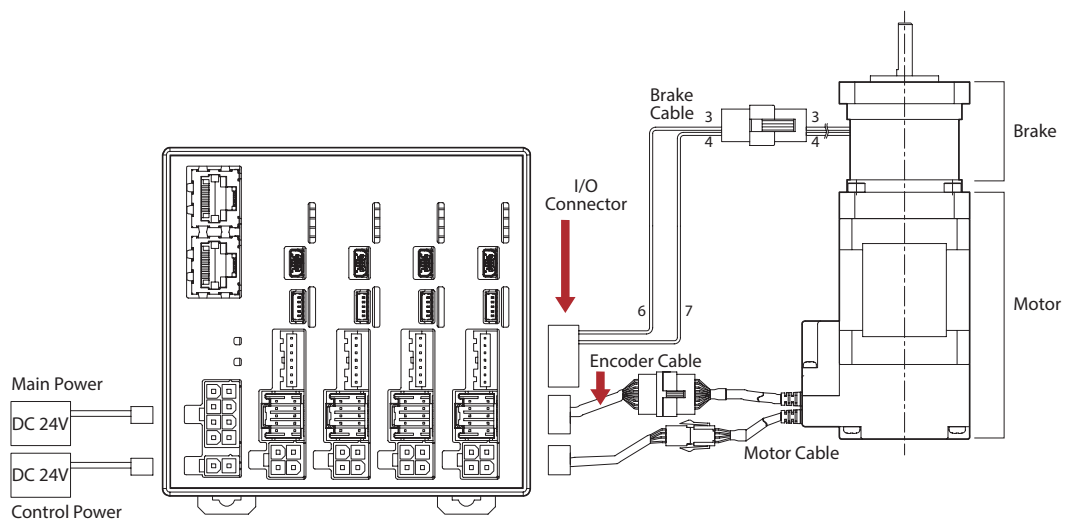

● Electrical Brake and Power Connection

Ezi-SERVOII EtherCAT ALL, Plus-E ALL_ M Type

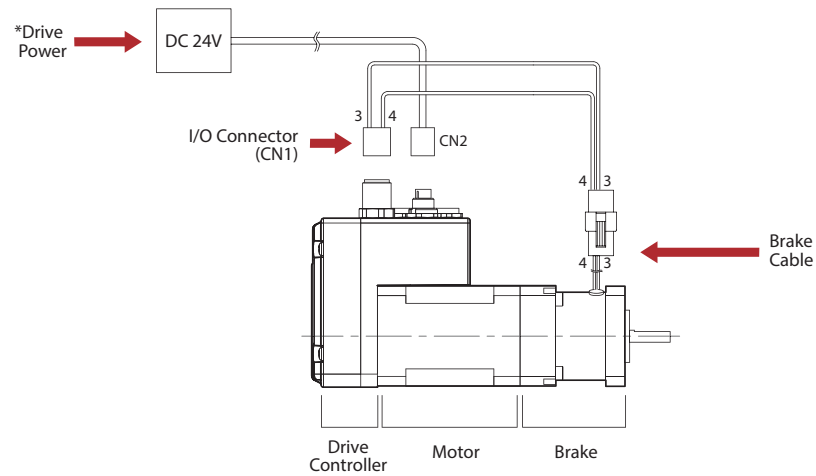

* In case of 86mm, the voltage of power supply is DC40~70V.

Ezi-SERVOII EtherCAT ALL, Plus-E ALL_ R Type

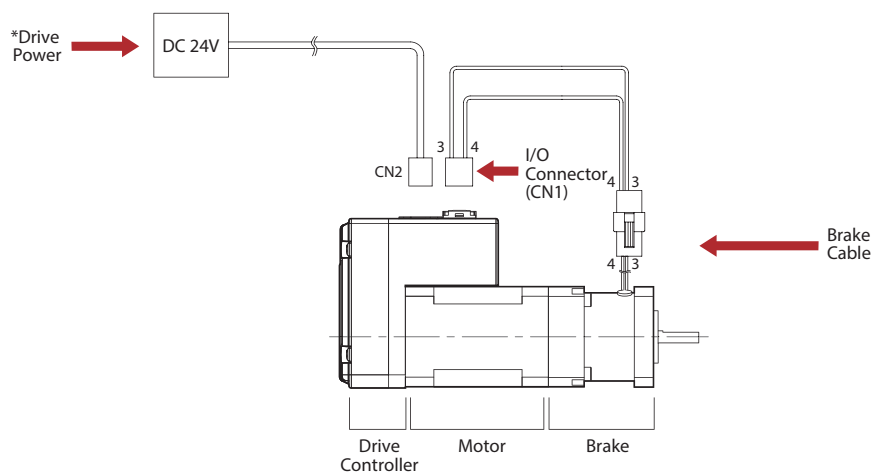

* In case of 86mm, the voltage of power supply is DC40~70V.

● Electrical Brake and Power Connection

Ezi-SERVOII EtherCAT MINI, Plus-E MINI

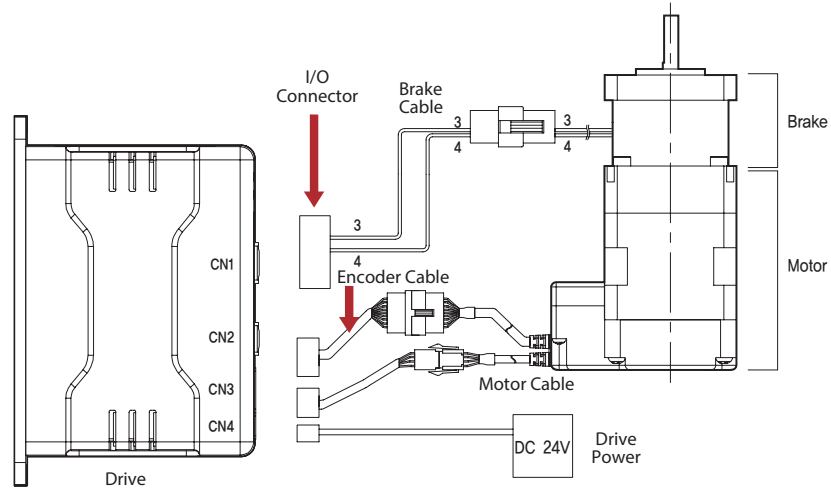

S-SERVOII ST, S-SERVOII 2X, 3X

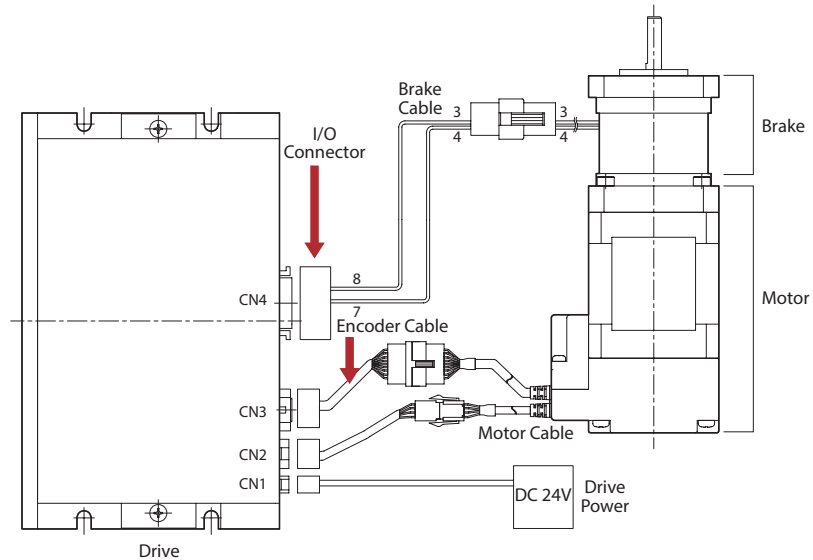

● Electrical Brake and Power Connection

Ezi-STEP ST

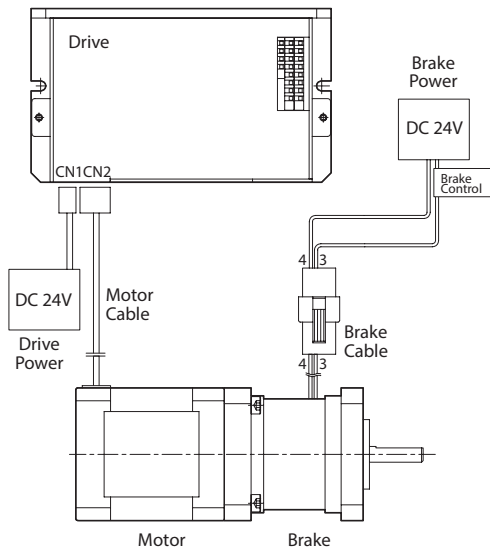

Ezi-STEP MINI

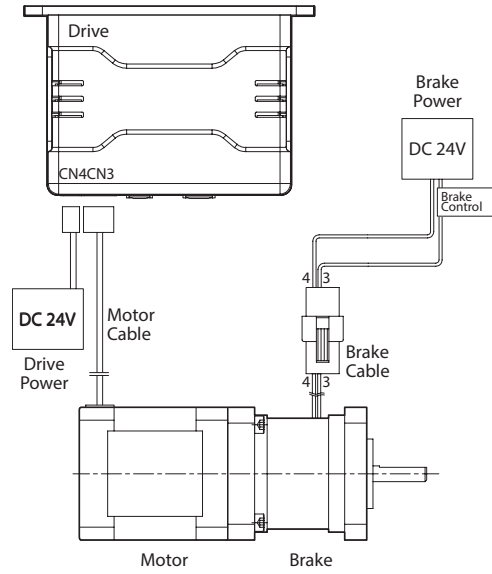

Ezi-STEP Plus-R

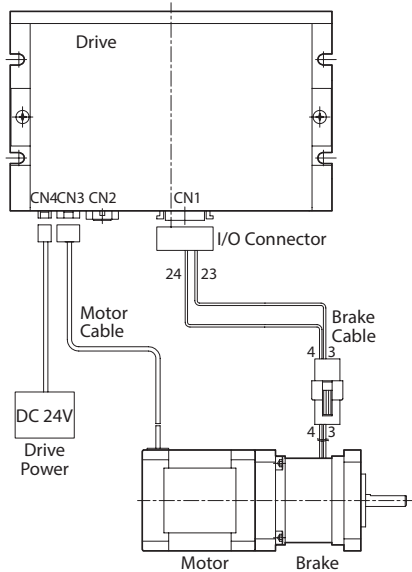

Ezi-STEP Plus-R_ 86mm

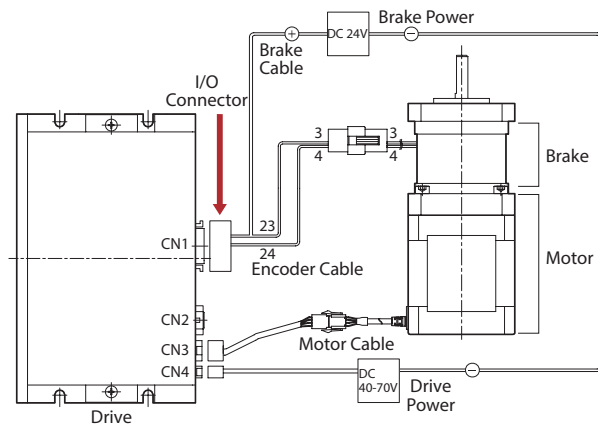

Option

Brake

Gearbox

● Electrical Brake and Power Connection

Ezi-STEP Plus-R MINI

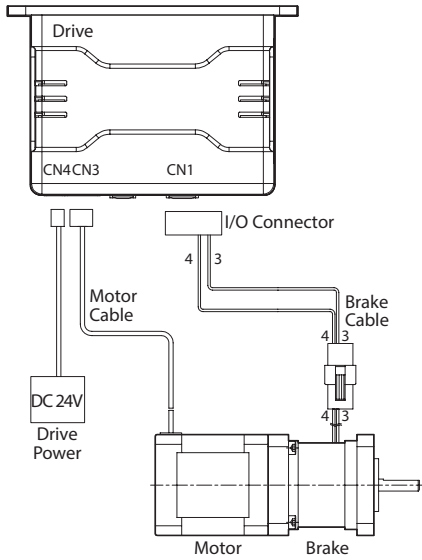

Ezi-STEP BT

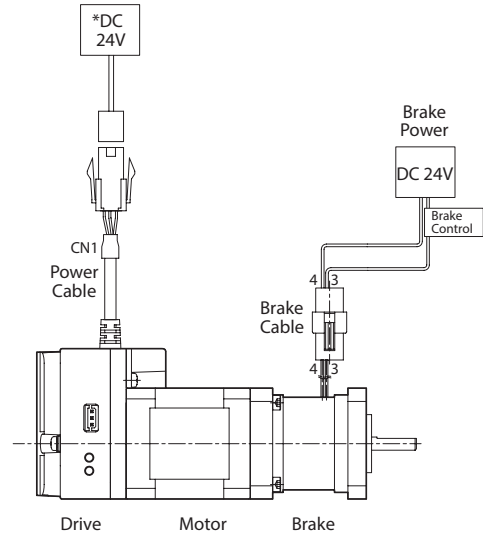

* In case of 86mm, the voltage of power supply is DC40~ 70V.

Ezi-SERVO ALL / Ezi-STEP ALL

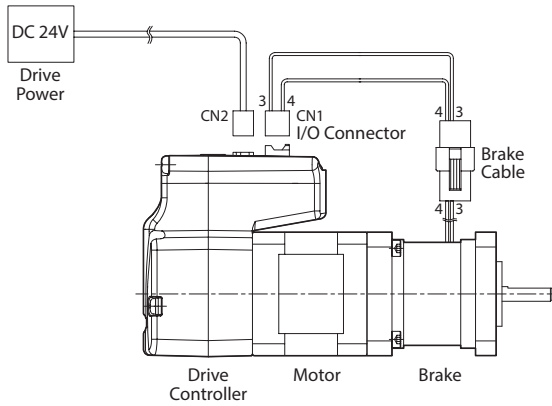

Ezi-STEPSII EtherCAT / Ezi-STEPSII EtherCAT_ 86mm

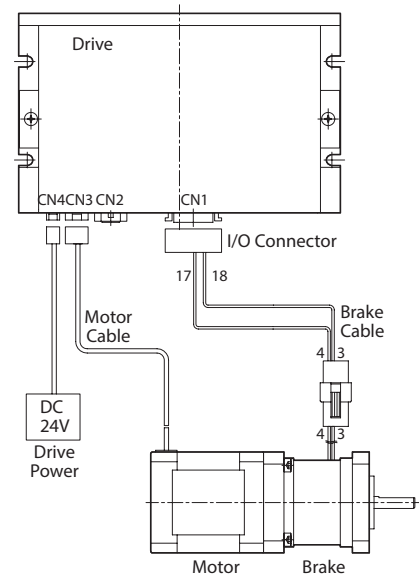

* In case of 86mm, the voltage of power supply is DC40~ 70V.

● Electrical Brake and Power Connection

Ezi-STEPII EtherCAT 4X

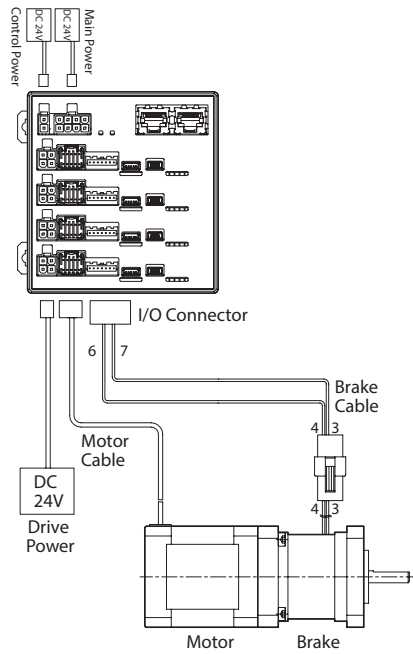

Ezi-STEPII Plus-E / Ezi-STEPII Plus-E_ 86mm

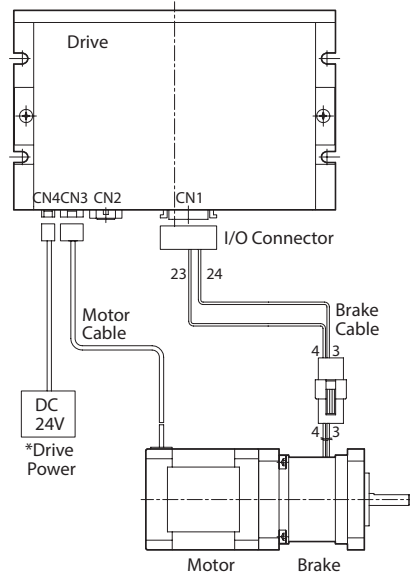

* In case of 86mm, the voltage of power supply is DC40~ 70V.

Ezi-STEPII EtherCAT MINI, Plus-E MINI

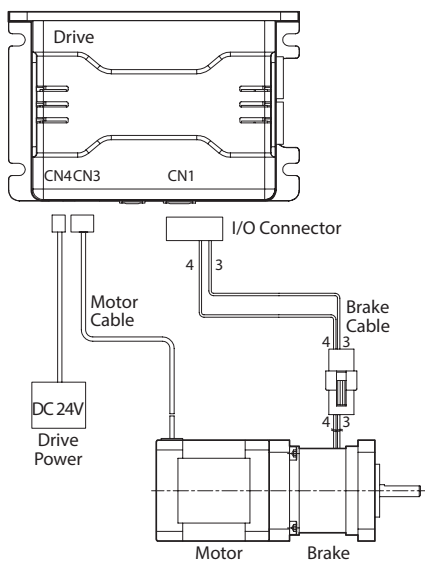

Ezi-STEPII CC-Link / Ezi-STEPII CC-Link_ 86mm

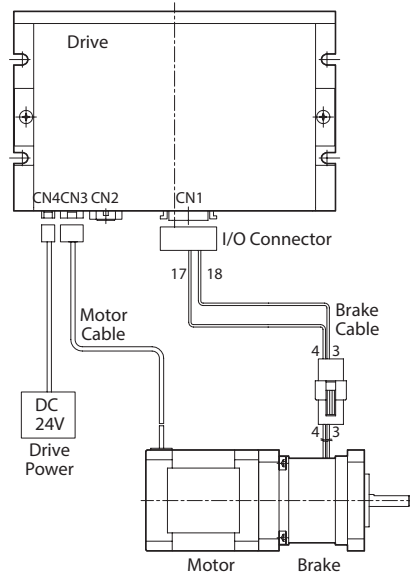

* In case of 86mm, the voltage of power supply is DC40~ 70V.



Ver. May_2021

20th
SINCE 2001

Ezi-SERVO[®]
Closed Loop Stepping System



Fast, Accurate, Smooth Motion

www.fastech-motions.com