





Linear system **ALLZQ 203**

RACK AND PINION DRIVE

-  ROLLER GUIDE
-  HEAVY LOAD
-  LIFTING SYSTEM
-  HIGH LOAD CAPACITY

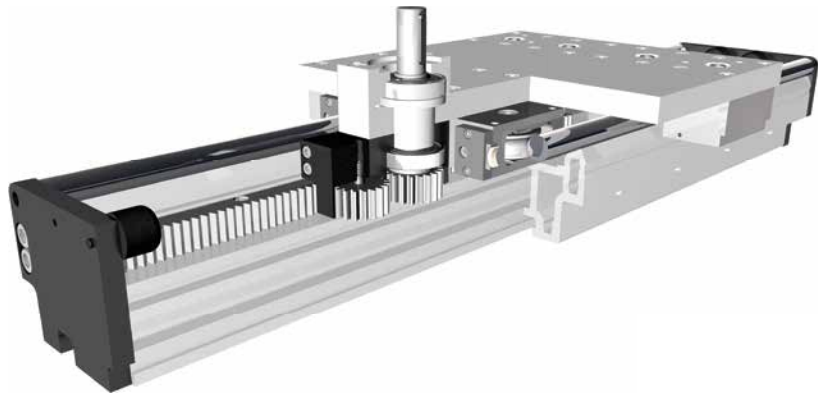

Function:

This unit consists of an aluminium profile with hardened steel guide rods mounted on top of the profile. The carriage, which has internal linear ball bearings that can be adjusted free of play, is driven along the guide rods by a high precision rack. The rack and pinion system is suitable for highly dynamic servo operation and ideal for lifting movements. The pinion has maintenance-free ball bearings. The rack is lubricated by a toothed felt wheel.

Fitting position:

As required. Max. length 5.000 mm without joints.

Carriage mounting:

By tapped holes.

Unit mounting:

By T-slots and mounting sets. The linear axis can be combined with any T-slot profile.

Carriage support:

In the standard version, the carriage runs on 8 rollers which can be adjusted and serviced at a central servicing position. For longer carriages the number of rollers can be increased. Repeatability ± 0,1.

Rack:

8e27 hardened and ground. Repeatability: ± 0,1 mm.

Forces and torques

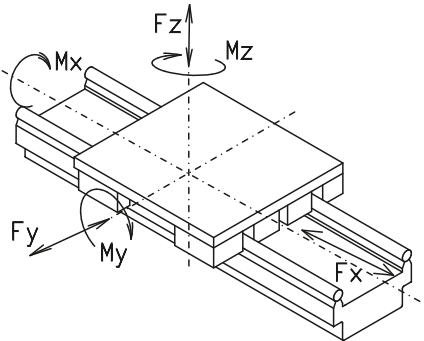

Size	ALLZQ 203
Forces/Torques	
F_x (N)	4610
F_y (N)	8700
F_z (N)	8300
M_x (Nm)	1050
M_y (Nm)	1240
M_z (Nm)	2600
All forces and torques related to the following:	
existing values	$\frac{F_y}{F_{y_{dyn}}} + \frac{F_z}{F_{z_{dyn}}} + \frac{M_x}{M_{x_{dyn}}} + \frac{M_y}{M_{y_{dyn}}} + \frac{M_z}{M_{z_{dyn}}} \leq 1$
table values	
No-load torque	
Nm	3
Driving Torque	
N	154
Geometrical moments of inertia of aluminium profile	
I_x mm ⁴	2,26x10 ⁷
I_y mm ⁴	8,75x10 ⁷
Elastic modulus N/mm ²	70000

For life-time calculation of rollers use our homepage.

14.1

Driving torque:

$$M_o = \frac{F \cdot P \cdot S_i}{2000 \cdot \pi} + M_n$$

$$P_o = \frac{M_o \cdot n}{9550}$$

- F = force (N)
- P = pulley action perimeter (mm)
- S_i = safety factor 1,2 ... 2
- M_n = no-load torque (Nm)
- n = rpm pulley (min⁻¹)
- M_o = driving torque (Nm)
- P_o = motor power (KW)

Deflection:

$$f = \frac{F \cdot L^3}{E \cdot I \cdot 192}$$

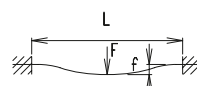

- f = deflection (mm)
- F = load (N)
- L = free length (mm)
- E = elastic modulus 70000 (N/mm²)
- I = second moment of area (mm⁴)

Linear system ALLZQ 203

Dimensions (mm)

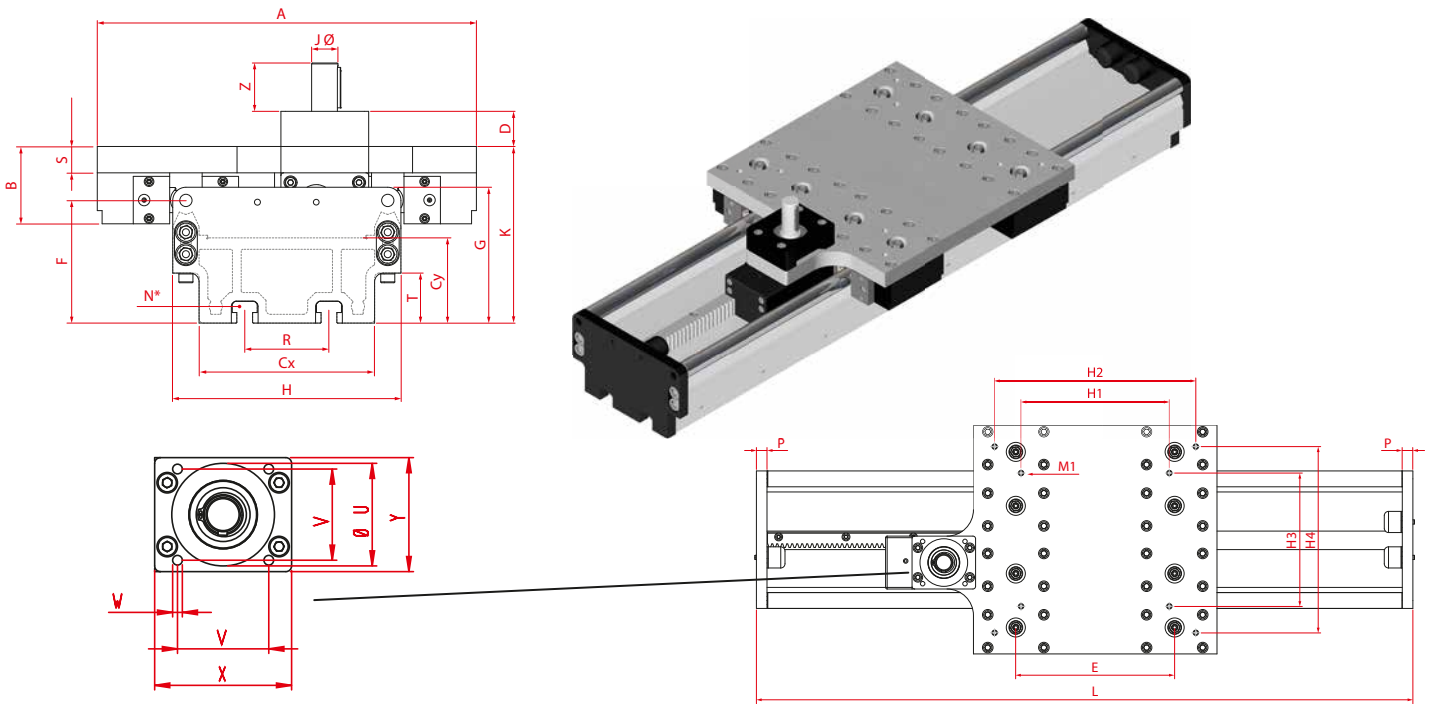

Increasing the carriage length will increase the basic length by the same amount.

Size	Basic length L	A	B	Cx	Cy	D	E	F	G	H	J Ø	K	N for	P	R	S	T	U ±0,05	V	W for	X	Y	Z	Basic weight	Weight per 100 mm
ALLZQ 203	670	432	88	200	97	40	300	139,6	154,6	260	30	200,6	M16	20	96	30	57	90	80	M10	120	100	55	77,6 kg	4,9 kg

3 Guide rod size:
(3) Ø=30

Carriage	E	H1	H2	H3	H4	M1
Version (0) & (1)	300	280	380	252	352	M12
Version (2) & (3)	355	330	430	252	352	M12

0 Choice of guide body profile:
(0) Standard (2) corrosion-protected guide rods and screws
(4) expanded corrosion-protected version (depending on the availability of components)

0 Drive version:

Size	Version (0) & (1)					Version (2) & (3)			
	I	M	Q1	Q2	L	I	M	Q2	L
203	172,75	516	626	460	670	172,75	294	510	560

Rack and pinion accuracy

Code No.	Modul	Quality	Rack accuracy	Material	Marks
0	3	10	0,091 mm/300 mm	C45	Hardened teeth
1	3	9	0,065 mm/300 mm	C45	Milled teeth
2	3	8	0,046 mm/300 mm	X8CrNiS18-9	Milled teeth

Shaft dimensions			
Shaft ø h6 x length	Key	Pinion	
		mm/U	Modul
30 x 55	8x7x50	197,92	3

ALLZQ 20 3 0 0 0 0 0 0 2000 — Basic length + stroke = total length

Pos. 1 2 3 4 5 6 7

Sample ordering code:
ALLZQ203, guide rods 30 mm, standard body profile, coupling position 0, rack accuracy 0,091 mm/300 mm, 1330 mm stroke.