

MA6

series



Product Segments

- **Industrial Motion**

Engineered by a unique design by TiMOTION, the MA6 series linear actuator is an excellent solution for applications that require heavy duty and incredible durability. Offering a high degree of protection up to IP69K, the MA6 can be constructed to withstand high-pressure water jets, ingress of dust, and other solid contaminants. Depending on the user's application requirements, the MA6 is customizable with a variety of feedback options for improved control and accuracy of motion. Robust, solid, and powerful, the MA6 is ideal for agricultural, commercial, and industrial applications such as combine harvesters, balers, lawn mowers, material handling equipment, livestock ventilation systems, and much more.

General Features

Max. load	8,000N (push/pull)
Max. speed at max. load	6.2mm/s
Max. speed at no load	64mm/s
Retracted length	≥ Stroke + 162mm
IP rating	IP69K
Stroke	25~1000mm
Output signals	Hall sensor(s), mechanical Pot., adjustable Reed switch
Voltage	12/24V DC; 12/24V DC (thermal switch)
Operational temperature range	-40°C~+85°C
Operational temperature range at full performance	+5°C~+45°C
Manual drive	

Drawing

Standard Dimensions
(mm)

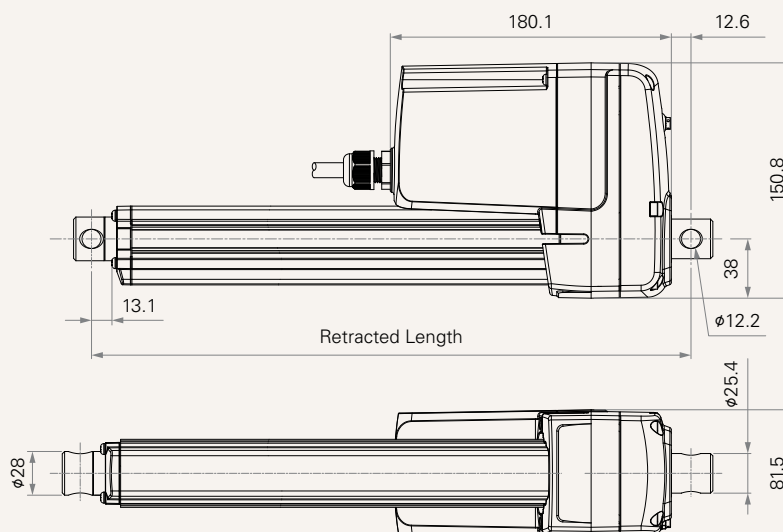

Load and Speed

CODE	Load (N)		Self Locking Force (N)	Duty Cycle	Typical Current (A)		Typical Speed (mm/s)	
	Push	Pull			No Load 24V DC	With Load 24V DC	No Load 24V DC	With Load 24V DC
Motor Speed (5100RPM)								
B	1000	1000	1300	25%	3.5	9.0	64.0	50.0
C	2000	2000	2600	25%	3.5	8.0	32.0	25.5
D	4000	4000	5200	25%	3.5	8.0	16.0	12.8
E	8000	8000	10400	25%	3.5	9.0	8.0	6.2

Note

- 1 Please refer to the approved drawing for the final authentic value.
- 2 The current & speed in table are tested with 24V DC motor. With a 12V DC motor, the current is approximately twice the current measured in 24V DC; speed will be similar for both voltages.
- 3 The current & speed in table are tested when the actuator is extending under push load.
- 4 The current & speed in table and diagram are tested with a stable 24V DC power supply.
- 5 With load, noise level ≤ 78 dB(A) (by TiMOTION test standard, ambient noise level ≤ 36 dB(A)).
- 6 Standard stroke: Min. 25mm, Max. please refer to the table below.

CODE	Load (N)	Max Stroke (mm)
B, C	≤ 2000	1000
D	≤ 4000	700
E	≤ 8000	300

Performance Data (24V DC Motor)

Motor Speed (5100RPM)

Speed vs. Load

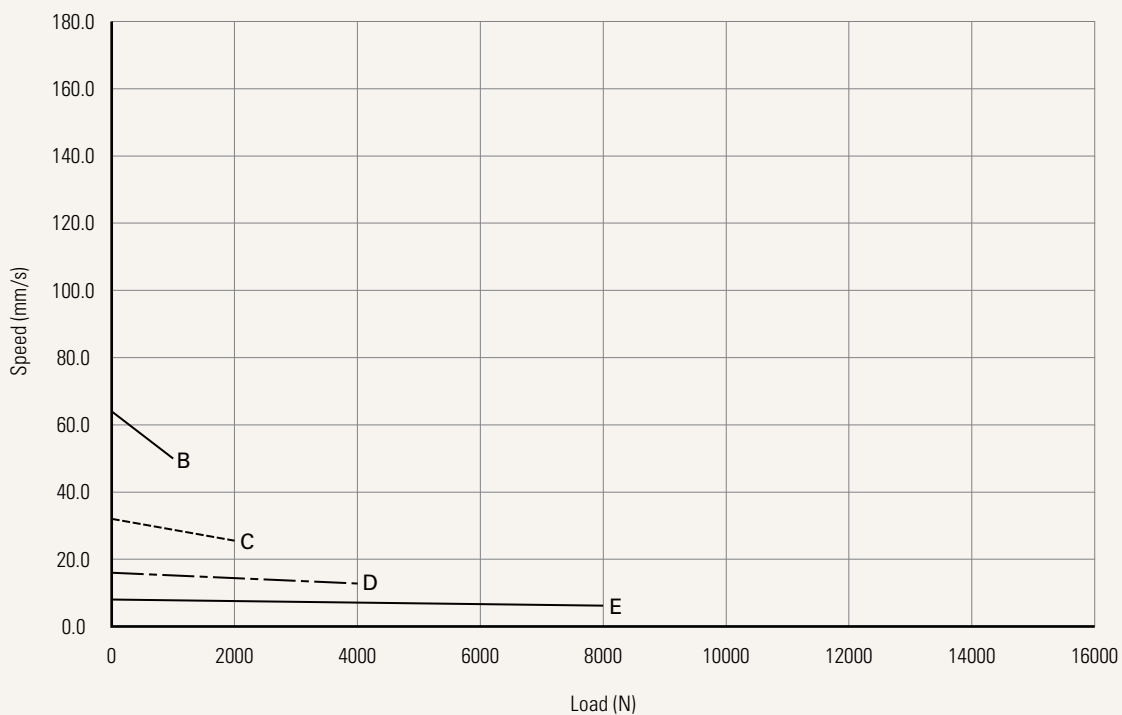

Current vs. Load

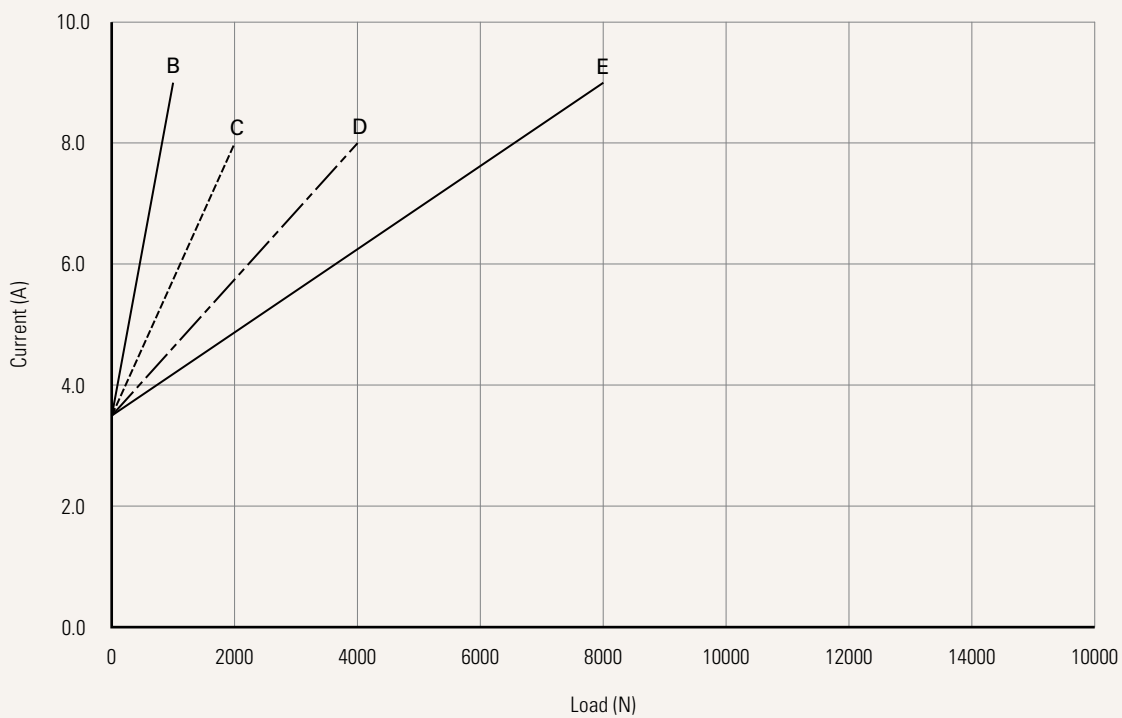

Hardware System	N = Without driver board			
Voltage	1 = 12V DC	2 = 24V DC	6 = 12VDC, thermal switch	5 = 24VDC, thermal switch
Load and Speed	See page 2			
Stroke (mm)	See page 2			
Retracted Length (mm)	See page 5			
Rear Attachment (mm)	1 = #45 Steel, slotless, hole 10.2		6 = #45 Steel, U clevis, slot 8.2, depth 12.5, hole 12.8	
See page 6	2 = #45 Steel, slotless, hole 12.2		7 = #45 Steel, U clevis, slot 8.2, depth 15.0, hole 10.2	
	3 = #45 Steel, slotless, hole 12.8		8 = #45 Steel, U clevis, slot 8.2, depth 15.0, hole 12.2	
	4 = #45 Steel, U clevis, slot 8.2, depth 12.5, hole 10.2		9 = #45 Steel, U clevis, slot 8.2, depth 15.0, hole 12.8	
	5 = #45 Steel, U clevis, slot 8.2, depth 12.5, hole 12.2			
Front Attachment (mm)	1 = #45 Steel, slotless, hole 10.2		8 = #45 Steel, U clevis, slot 8.2, depth 15.0, hole 12.2	
See page 6-7	2 = #45 Steel, slotless, hole 12.2		9 = #45 Steel, U clevis, slot 8.2, depth 15.0, hole 12.8	
	3 = #45 Steel, slotless, hole 12.8		K = Rod end bearing, hole 12.8	
	7 = #45 Steel, U clevis, slot 8.2, depth 15.0, hole 10.2			
Direction of Rear Attachment (Counterclockwise)	1 = 0°		3 = 90°	
See page 7				
Function of Limit Switches	1 = Two micro switches cut off the actuator at end of stroke			
See page 8	2 = Two micro switches send signal at end of stroke (signal type: normally closed)			
Adjustable Reed Switch	0 = Without		2 = Reed switch*2, tinned leads	
	1 = Reed switch*1, tinned leads			
Output Signal	0 = Without	1 = Mechanical Pot.	4 = Hall sensor*1	5 = Hall sensor*2
IP Rating	1 = Without	7 = IP67	9 = IP69K	
	6 = IP66M	8 = IP68		
Cable Exit	1 = Single cable			
A1 / P1 Connector (mm)	01 = Tinned leads, unsheathed wire 50, stripped wire 4			
See page 7				
A1 / P1 Cable Length (mm)	0500 = 500	1000 = 1000	1500 = 1500	2000 = 2000
P2 Connector	NN = Without			
P2 Cable Length	0000 = Without			
P3 Connector	NN = Without			
P3 Cable Length	0000 = Without			
Bus Interface	0 = Without			
Packaging (mm²)	0 = Sample packaging		E = Standard package, US plywood pallet (1219*1016 ^{^2})	
	C = Standard package, US fumigated pallet (1219*1016 ^{^2})		5 = Standard package, EU plywood pallet (1200*800 ^{^2})	
	1 = Standard package, EU fumigated pallet (1200*800 ^{^2})		6 = Standard package, EU plywood pallet (1500*800 ^{^2})	
	2 = Standard package, EU fumigated pallet (1500*800 ^{^2})			

Retracted Length (mm)

1. Calculate $A+B+C+D = Y$
2. Minimum retracted length is $\text{Stroke}+Y$

Note

¹ Depending on the attachments, the motor cover might interfere with the customer's device when retracted length is between 225~318mm. Please confirm before placing order.

A.		
Front Attach.	Rear Attach.	
	1, 2, 3, 4, 5, 6	7, 8, 9
1, 2, 3	+162	+165
7, 8, 9	+175	+178
K	+185	+188

B.	
Stroke (mm)	Load & Speed Type (N)
	B, C, D, E
25~150	-
151~200	-
201~250	+10
251~300	+20
301~350	+30
351~400	+40
401~450	+50
451~500	+60
501~550	+70
551~600	+80
601~650	+90
651~700	+100
701~750	+110
751~800	+120
801~850	+130
851~900	+140
901~950	+150
951~1000	+160

C.	
Output Signal	
0, 4, 5	-
1	+18

Rear Attachment (mm)

1 = #45 Steel, slotless, hole 10.2

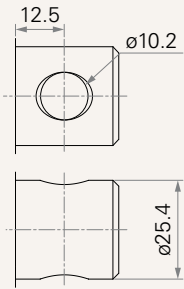

2 = #45 Steel, slotless, hole 12.2

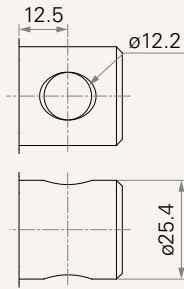

3 = #45 Steel, slotless, hole 12.8

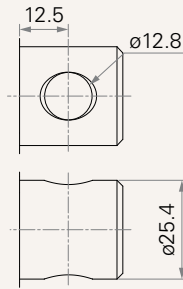

4 = #45 Steel, U clevis, slot 8.2, depth 12.5, hole 10.2

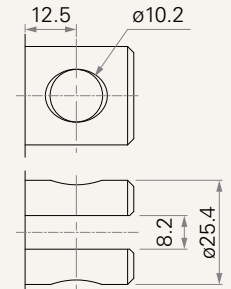

5 = #45 Steel, U clevis, slot 8.2, depth 12.5, hole 12.2

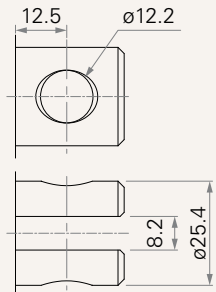

6 = #45 Steel, U clevis, slot 8.2, depth 12.5, hole 12.8

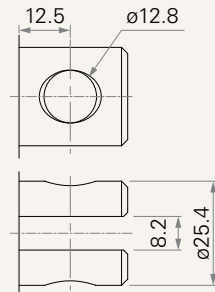

7 = #45 Steel, U clevis, slot 8.2, depth 15.0, hole 10.2

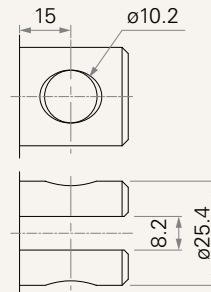

8 = #45 Steel, U clevis, slot 8.2, depth 15.0, hole 12.2

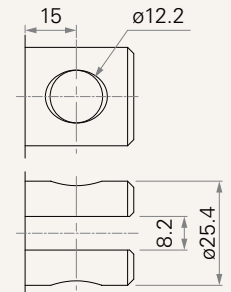

9 = #45 Steel, U clevis, slot 8.2, depth 15.0, hole 12.8

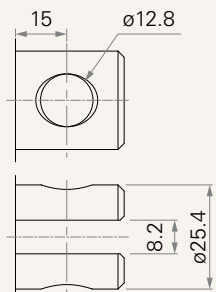

Front Attachment (mm)

1 = #45 Steel, slotless, hole 10.2

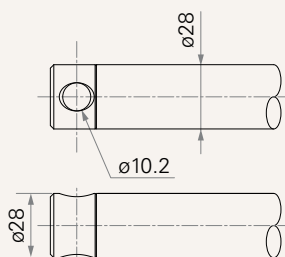

2 = #45 Steel, slotless, hole 12.2

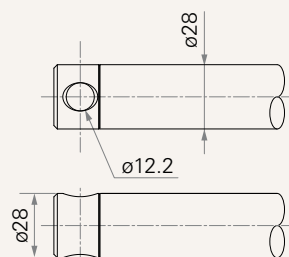

3 = #45 Steel, slotless, hole 12.8

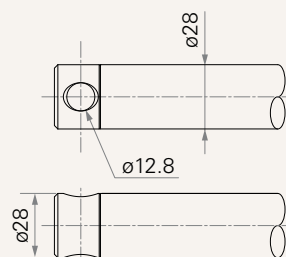

7 = #45 Steel, U clevis, slot 8.2, depth 15.0, hole 10.2

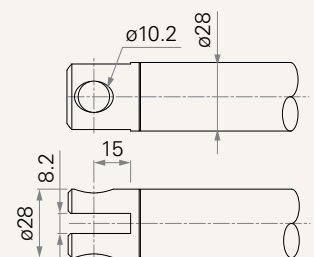

Front Attachment (mm)

8 = #45 Steel, U clevis, slot 8.2, depth 15.0, hole 12.2

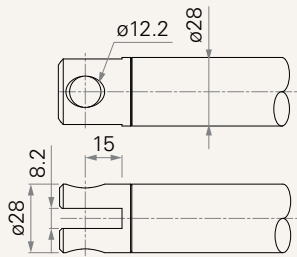

9 = #45 Steel, U clevis, slot 8.2, depth 15.0, hole 12.8

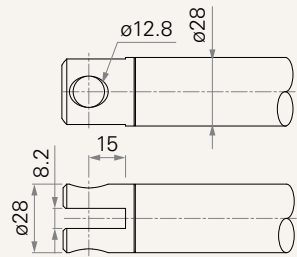

K = Rod end bearing, hole 12.8

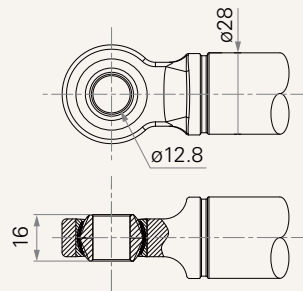

Direction of Rear Attachment (Counterclockwise)

1 = 0°

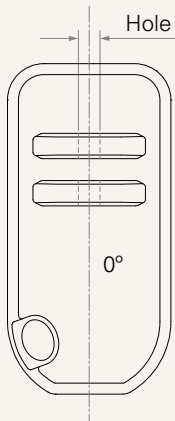

3 = 90°

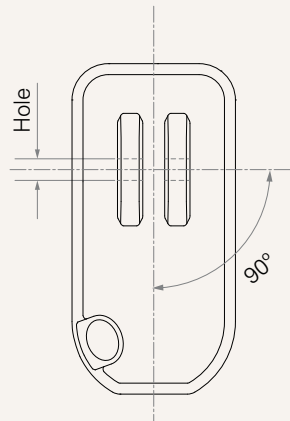

Connector (mm)

01 = Tinned leads, unsheathed wire
50, stripped wire 4

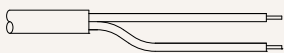

Wire Definition

Without T-Smart

Port Number	Functions for Limit Switches	Wire Color	Wire Gauge (AWG)	Position Feedback			
				0. Without	1. Pot.	4. Hall sensor*1	5. Hall sensor*2
P1	Limit switches cut off the acuator	● RD	14	EXT+	EXT+	EXT+	EXT+
		● BK	14	RET+	RET+	RET+	RET+
		● RD	20	-	V-out	+5V	+5V
		○ WH	20	-	V-in	S1	S1
		● BU	20	-	-	-	S2
		● BK	20	-	GND	GND	GND
		● BN	20	-	-	-	-
		● OG	20	-	-	-	-
		● VT	20	-	-	-	-
P1	Limit switches send signal	● RD	14	EXT+	EXT+	EXT+	EXT+
		● BK	14	RET+	RET+	RET+	RET+
		● RD	20	COM	COM	+5V	+5V
		○ WH	20	EOS-extended	EOS-extended	S1	S1
		● BU	20	EOS-retracted	EOS-retracted	-	S2
		● BK	20	-	GND	GND	GND
		● BN	20	-	V-in	EOS-extended	EOS-extended
		● OG	20	-	V-out	EOS-retracted	EOS-retracted
		● VT	20	-	-	COM	COM

Terms of Use

The user is responsible for determining the suitability of TiMOTION products for a specific application. TiMOTION products are subject to change without prior notice.