

TA5P

series

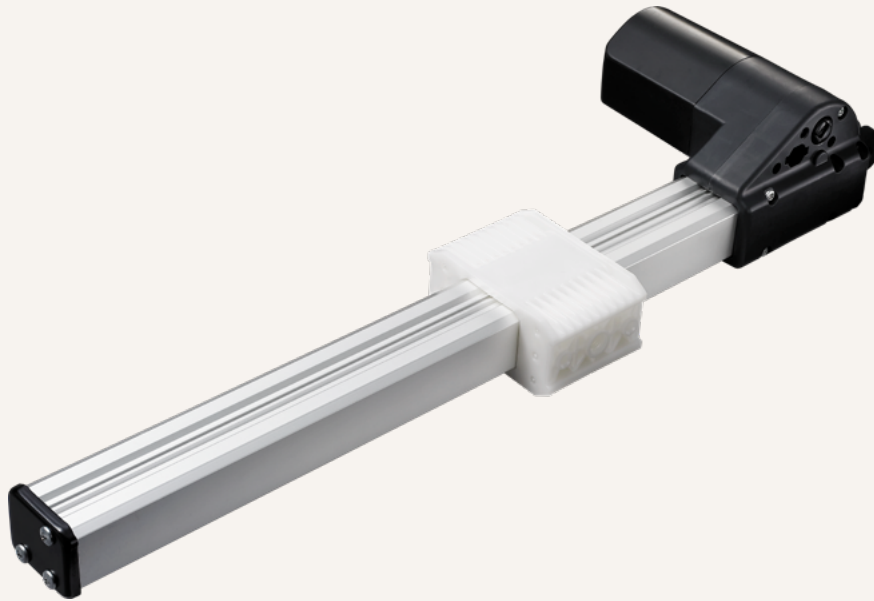

Product Segments

• Comfort Motion

TiMOTION's TA5P is designed using a one-piece aluminum outer cover for increased strength and enhanced protection from contaminants. The TA5P utilizes a linear slide to move the load, instead of a standard extension tube. Industry certifications for the TA5P include EMC, and RoHS. It is also available with Hall sensors for position feedback and a special L-shaped mounting bracket.

General Features

Max. load	6,000N (push) 3,000N (pull)
Max. speed at max. load	4.1mm/s
Max. speed at no load	58mm/s
Retracted length	≥ 157mm
Certificate	UL962, EN 61000-6-1, EN 61000-6-3
Options	Hall sensors, L-shaped bracket
Voltage	12 / 24 / 36V DC
Color	Black
Specially designed for recliner	
One-piece design, stronger structure, cable-free	

Drawing

Standard Dimensions
(mm)

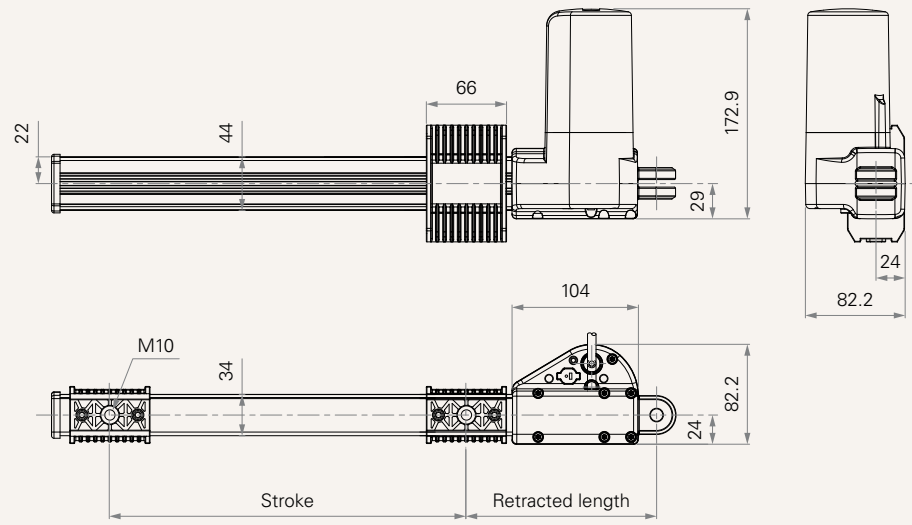

Load and Speed

CODE	Load (N)		Self Locking Force (N)	Typical Current at Rated Load (A)		Typical Speed (mm/s)	
	Push	Pull		No Load 32V DC	With Load 24V DC	No Load 32V DC	With Load 24V DC
Motor Speed (2600RPM, Duty Cycle 10%)							
A	750	750	750	1.0	2.8	47.0	25.0
C	5000	3000	5000	1.0	3.5	7.5	3.9
D	6000	3000	6000	1.0	3.5	6.0	3.1
E	3000	3000	3000	1.0	3.2	11.5	6.6
F	2500	2500	2500	1.0	3.5	17.5	8.5
G	2000	2000	2000	1.0	3.5	23.0	13.3
H	1200	1200	1200	1.0	3.2	34.5	18.5
J	3000	3000	3000	1.0	3.3	11.9	6.0
Motor Speed (3400RPM, Duty Cycle 10%)							
L	6000	3000	6000	1.1	4.0	7.5	4.1
M	3000	3000	3000	1.1	3.4	14.6	8.3
N	2500	2500	2500	1.1	4.1	22.0	12.0
O	2000	2000	2000	1.1	4.6	29.0	15.5
P	1200	1200	1200	1.1	3.6	43.5	23.5
Q	3000	3000	3000	1.1	4.2	14.5	7.6
S	750	750	750	1.1	3.5	58.0	32.5
T	5000	3000	5000	1.1	4.2	9.3	5.3

Note

- 1 Option C / D / E / F / G / J / L / M / N / O / Q / T use iron bearing, others use plastic.
- 2 Please refer to the approved drawing for the final authentic value.
- 3 This self-locking force level is reached only when a short circuit is applied on the terminals of the motor. All the TiMOTION control boxes have this feature built-in.
- 4 Operational temperature range at full performance: +5°C~+45°C
- 5 The current & speed in table are tested with 24V DC motor. With a 12V DC motor, the current is approximately twice the current measured in 24V DC. With a 36V DC motor, the current is approximately two-thirds the current measured in 24V DC. Speed will be similar for all the voltages.
- 6 The current & speed in table are tested when the actuator is extending under push load.
- 7 The current & speed in table and diagram are tested with TiMOTION control boxes, and there will be around 10% tolerance depending on different models of the control box. (Under no load condition, the voltage is around 32V DC. At rated load, the voltage output will be around 24V DC)

Performance Data (24V DC Motor)

Motor Speed (2600RPM, Duty Cycle 10%)

Speed vs. Load

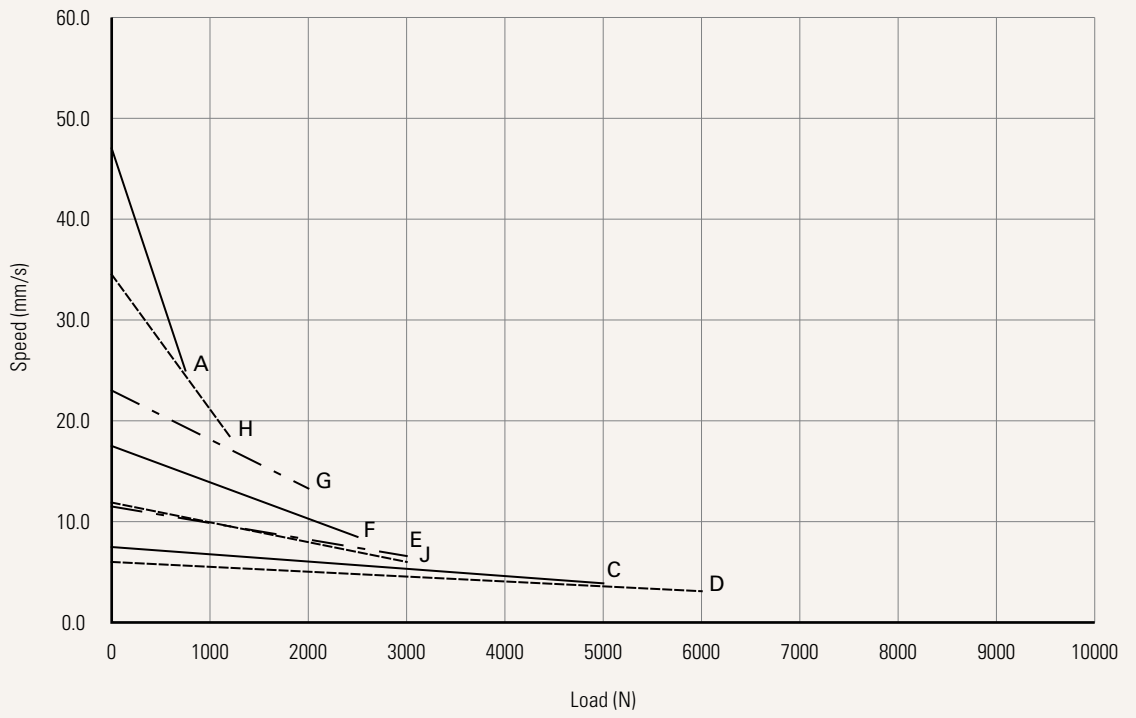

Current vs. Load

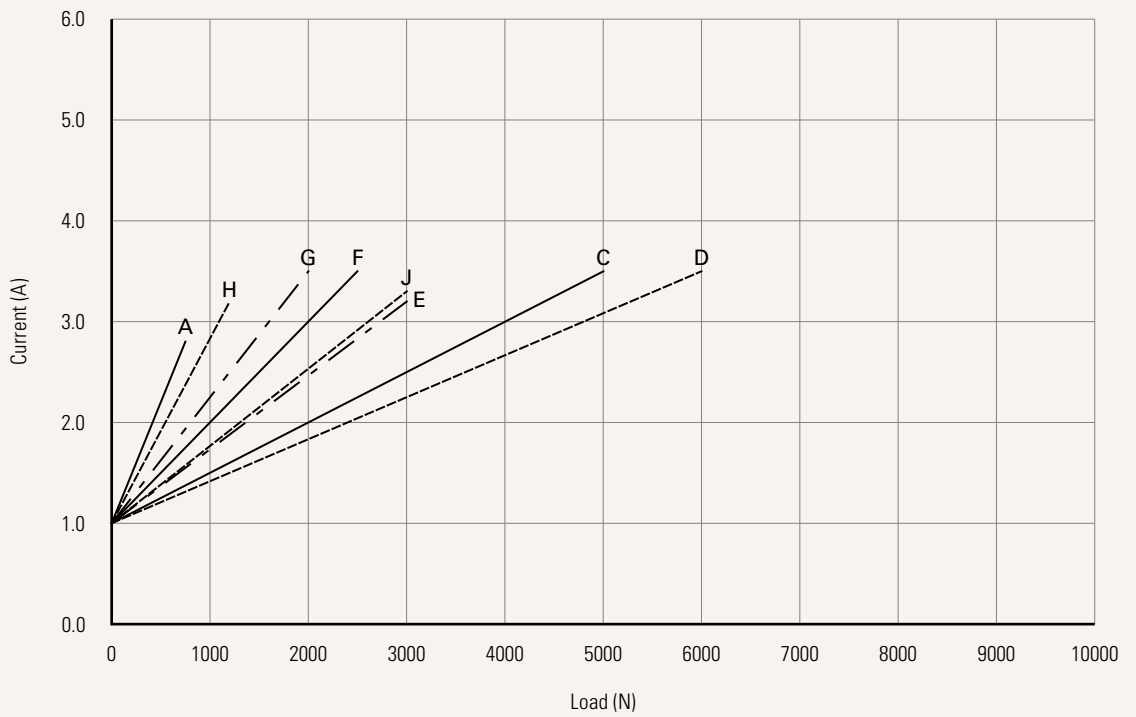

Performance Data (24V DC Motor)

Motor Speed (3400RPM, Duty Cycle 10%)

Speed vs. Load

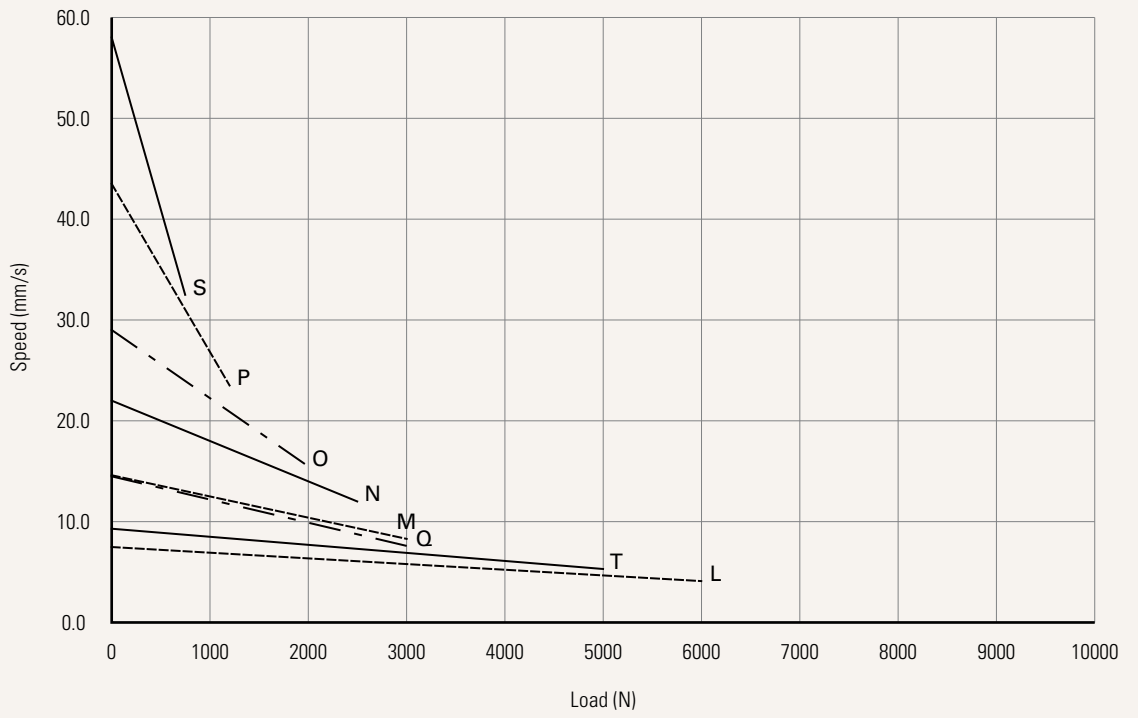

Current vs. Load

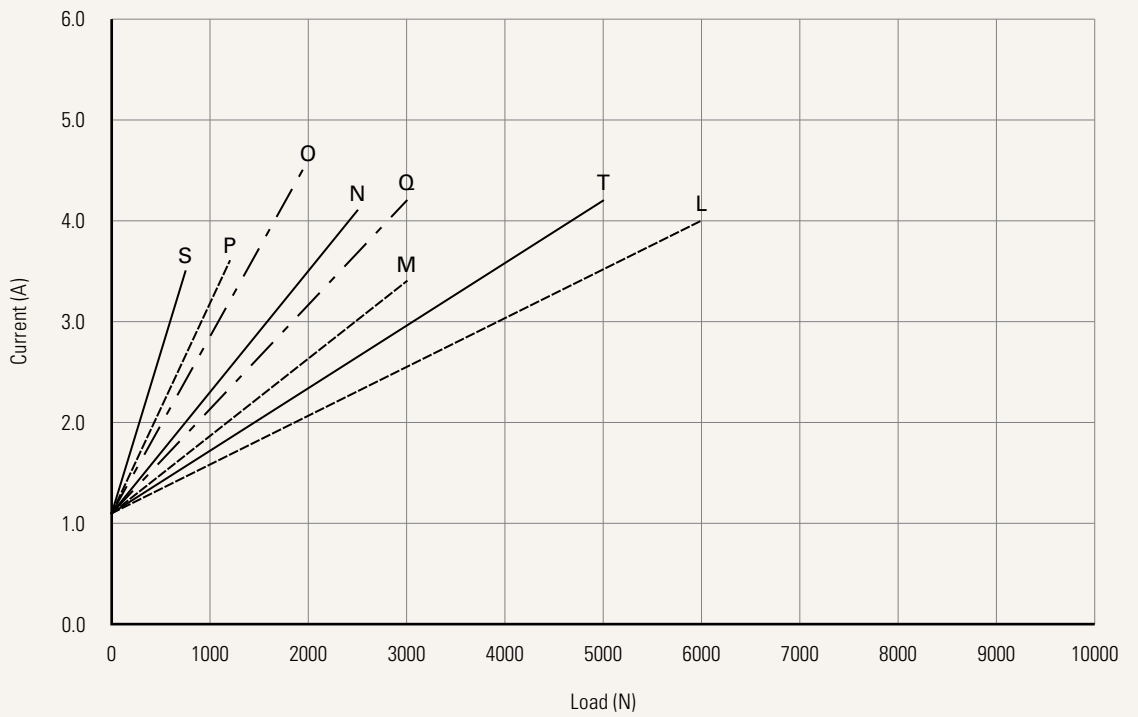

Voltage	1 = 12V DC	2 = 24V DC	3 = 36V DC
Load and Speed	See page 3		
Stroke (mm)	Note: please contact TIMOTION before making an order		
Retracted Length (mm)	≥ 157		
L-Shaped Bracket on The Front	0 = Without	1 = With	
Functions for Limit Switches See page 7	1 = Two switches at full retracted / extended positions to cut current 2 = Two switches at full retracted / extended positions to cut current + third one in between to send signal 3 = Two switches at full retracted / extended positions to send signal 4 = Two switches at full retracted / extended positions to send signal + third one in between to send signal		
Output Signal	0 = Without	2 = Hall sensor*2	
Plug See page 7	1 = DIN 6P, 90°	2 = Tinned leads	
Cable Length (mm)	0 = Without (for direct cut system, no cable) 1 = Straight, 500	2 = Straight, 750 3 = Straight, 1000 4 = Straight, 1250	5 = Straight, 1500 6 = Straight, 2000 7 = Curly, 200 8 = Curly, 400
The Slot Position on Outer Tube	1 = Front	2 = Reverse	

Functions for Limit Switches

Wire Definitions

CODE	Pin					
	● 1 (Green)	● 2 (Red)	○ 3 (White)	● 4 (Black)	● 5 (Yellow)	● 6 (Blue)
1	extend (VDC+)	N/A	N/A	N/A	retract (VDC+)	N/A
2	extend (VDC+)	N/A	middle switch pin B	middle switch pin A	retract (VDC+)	N/A
3	extend (VDC+)	common	upper limit switch	N/A	retract (VDC+)	lower limit switch
4	extend (VDC+)	common	upper limit switch	medium limit switch	retract (VDC+)	lower limit switch

Plug

1 = DIN 6P, 90°

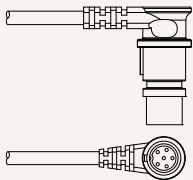

2 = Tinned leads

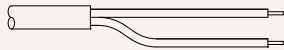

Terms of Use

The user is responsible for determining the suitability of TiMOTION products for a specific application. TiMOTION products are subject to change without prior notice.