

VN1

series

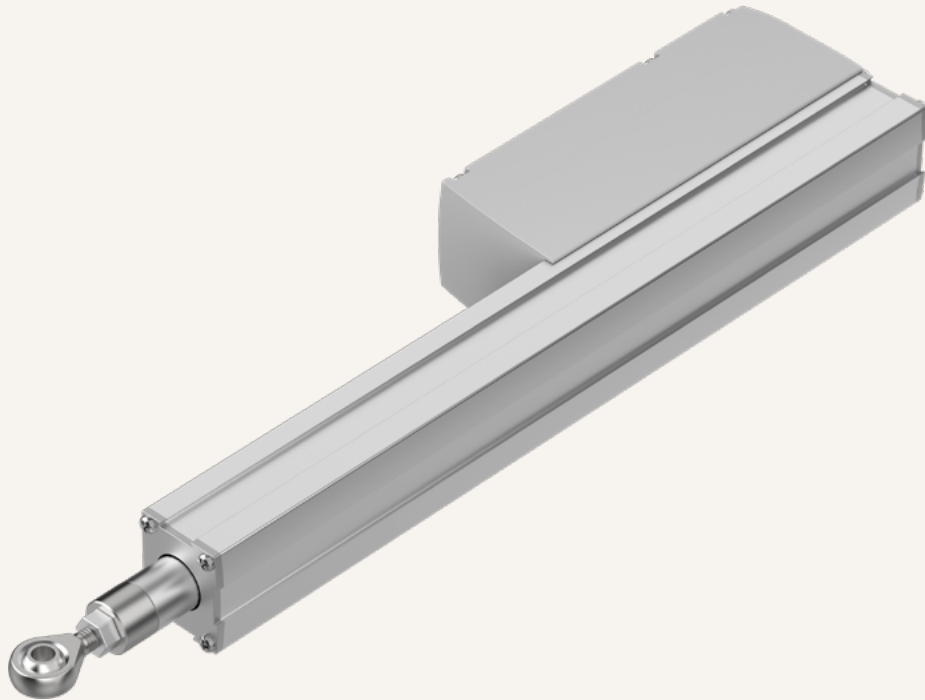

Product Segments

- **Industrial Motion**

The VN1 series linear actuator was specifically designed for ventilation applications to help remove smoke, heat, and toxic gases from the building quickly in the event of a fire. It was also designed to create a minimum smoke layer in the lower parts of the room. The VN1 is made of high-quality aluminum, suitable for applications like fall-through protection systems and greenhouses. The VN1 is equipped with either a 12V or 24V DC motor. The AC version of the VN1 is equipped with a built-in SMPS which allows the supply of alternating current.

General Features

Max. load	3,500N (push/pull)
Max. speed at max. load	4.2mm/s
Max. speed at no load	10.4mm/s
Retracted length	≥ 181mm (DC version, w/o T-Smart; depending on chosen options); ≥401mm (AC version; depending on chosen options)
IP rating	IP66
Stroke	20~500mm
Output signals	Hall sensors
Options	Safety nut, window seal mechanism, T-Smart
Voltage	12/24V DC; 100~240V AC (50Hz)
Color	Black, grey
Operational temperature range	-15°C~+50°C
Operational temperature range at full performance	+5°C~+45°C

Drawing

Dimensions
with DC Voltage
(mm)

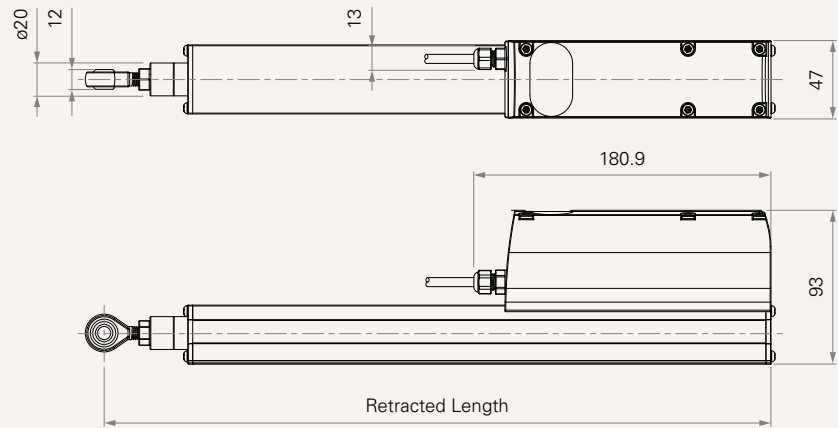

Dimensions
with AC Voltage
(mm)

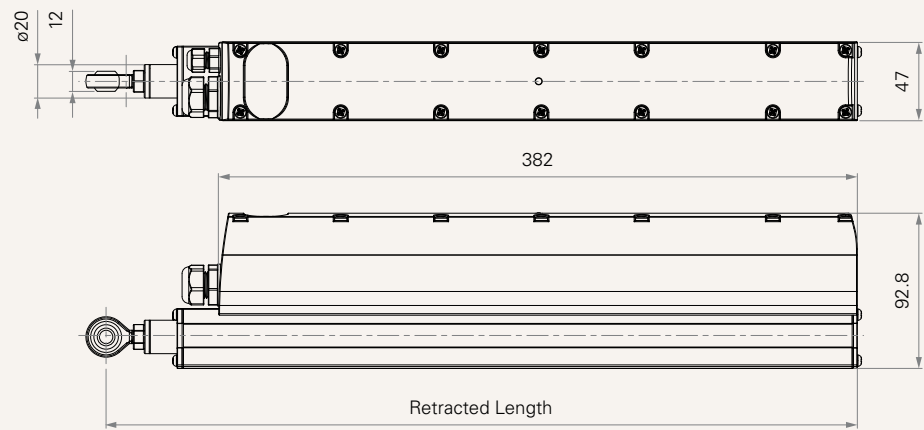

Load and Speed - DC Motor

CODE	Load (N)		Self Locking Force (N)	Typical Current (A)		Typical Speed (mm/s)	
	Push	Pull		No Load 24V DC	With Load 24V DC	No Load 24V DC	With Load 24V DC
Motor Speed (5200RPM, Duty Cycle 30%)							
B	500	500	500	1.5	1.7	10.4	8.3
C	1000	1000	1000	1.5	1.7	6.5	5.1
Motor Speed (5200RPM, Duty Cycle 10%)							
D	2000	2000	2000	1.5	2.9	10.4	7.4
E	3500	3500	3500	1.5	3.9	6.5	4.2

Note

- 1 Please refer to the approved drawing for the final authentic value.
- 2 This self-locking force level is reached only when a short circuit is applied on the terminals of the motor. All the TiMOTION control boxes have this feature built-in.
- 3 The current & speed in table are tested with 24V DC motor. With a 12V DC motor, the current is approximately twice the current measured in 24V DC; speed will be similar for both voltages. If choosing the voltage option #U, its performance is as the same as 24V DC motor.
- 4 The current & speed in table are tested when the actuator is extending under push load.
- 5 The current & speed in table and diagram are tested with TiMOTION control boxes, and there will be around 10% tolerance depending on different models of the control box. (Under no load condition, the voltage is around 32V DC. At rated load, the voltage output will be around 24V DC)
- 6 Standard stroke: Min. ≥ 20 mm, Max. please refer to below table.

CODE	Load (N)	Max Stroke (mm)
E	≤ 3500	300
D	≤ 2000	450
B, C	≤ 1000	500

7

Application	Outer Tube Adjust. Attach.	Rear Attach. #1, #2, #3
Push Application	≤ 1500 N	-
Pull Application	≤ 1500 N	≤ 2000 N

Load and Speed - AC Motor

CODE	Load (N)		Self Locking Force (N)	Typical Current (A)		Typical Speed (mm/s)	
	Push	Pull		No Load	With Load	No Load	With Load
				220VAC	220VAC	220VAC	220VAC
Motor Speed (5200RPM, Duty Cycle 30%)							
B	500	500	500	0.15	0.7	10.4	8.3
C	1000	1000	1000	0.15	0.7	6.5	5.1
Motor Speed (5200RPM, Duty Cycle 10%)							
D	2000	2000	2000	0.15	1.2	10.4	7.4
E	3500	3500	3500	0.15	1.2	6.5	4.2

Note

- Please refer to the approved drawing for the final authentic value.
The load speed is tested during 50Hz condition.
- This self-locking force level is reached only when a short circuit is applied on the terminals of the motor. All the TiMOTION control boxes have this feature built-in.
- The current & speed in table are tested when the actuator is extending under push load.
- Standard stroke: Min. ≥ 20 mm, Max. please refer to below table.

CODE	Load (N)	Max Stroke (mm)
E	≤ 3500	300
D	≤ 2000	450
B, C	≤ 1000	500

5

Application	Outer Tube Adjust. Attach.	Rear Attach. #1, #2, #3
Push Application	≤ 1500 N	-
Pull Application	≤ 1500 N	≤ 2000 N

Performance Data (24V DC Motor)

Motor Speed (5200RPM, Duty Cycle 30%)

Speed vs. Load

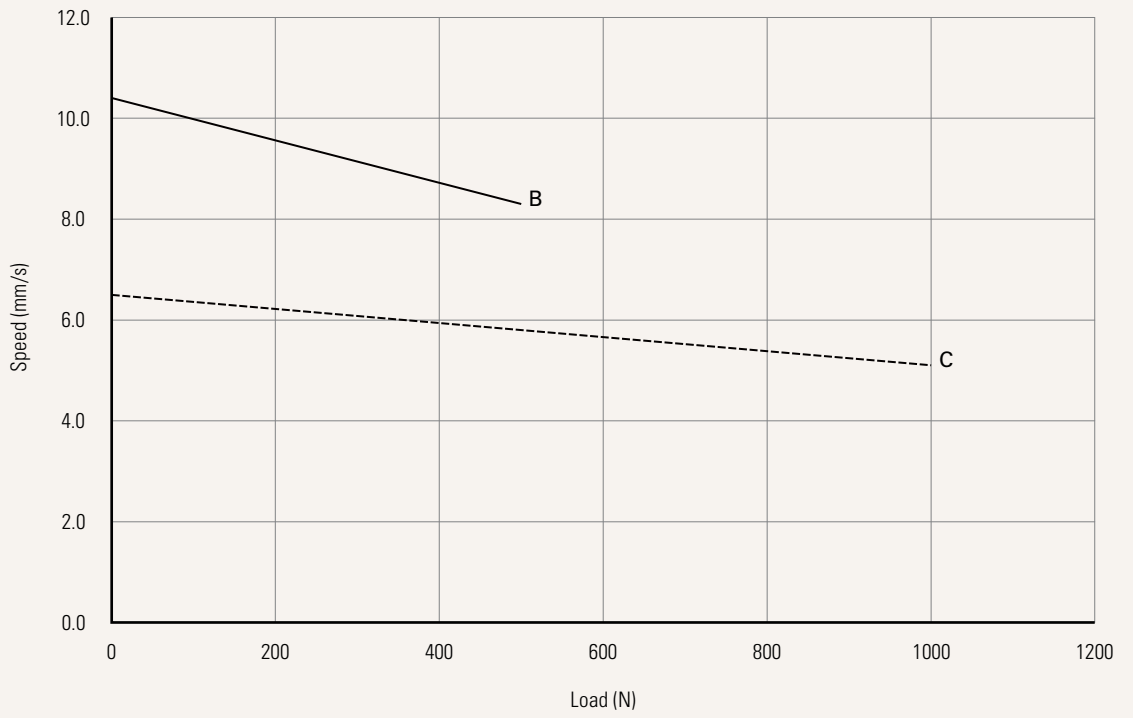

Current vs. Load

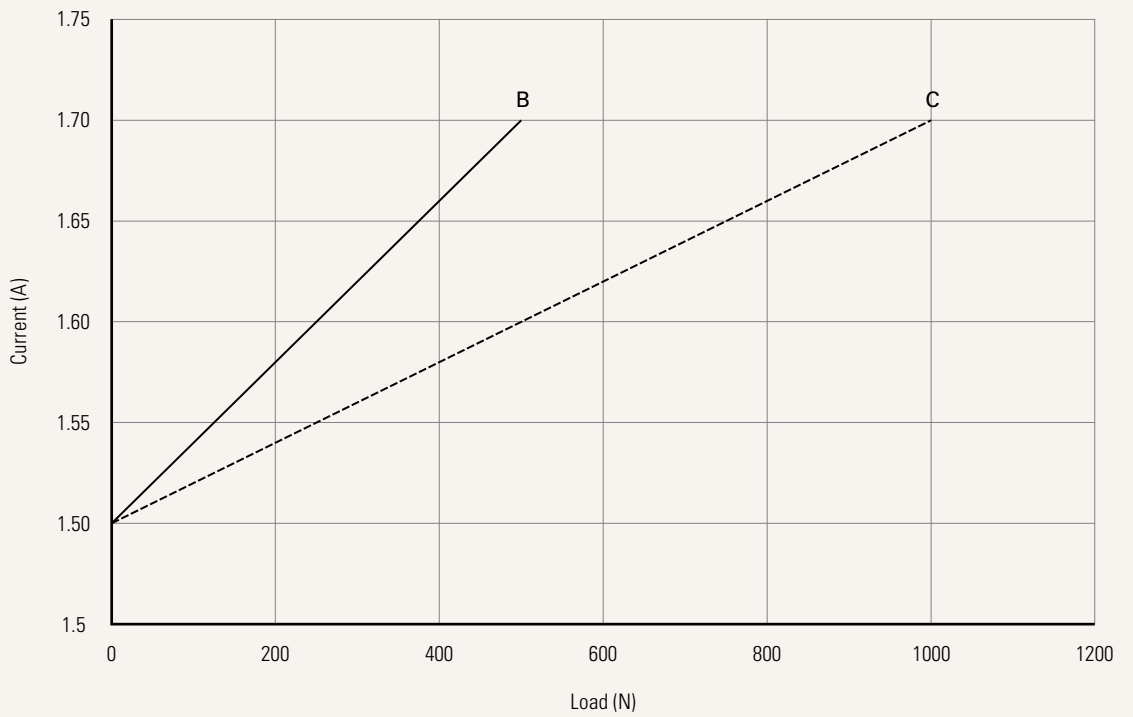

Performance Data (24V DC Motor)

Motor Speed (5200RPM, Duty Cycle 10%)

Speed vs. Load

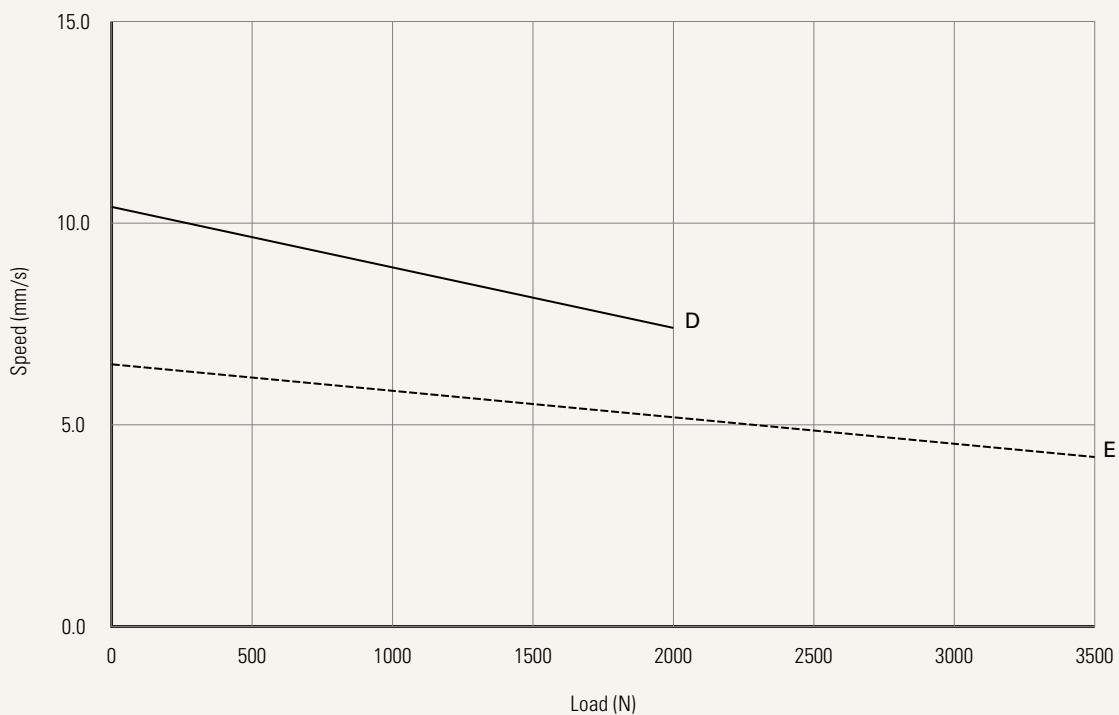

Current vs. Load

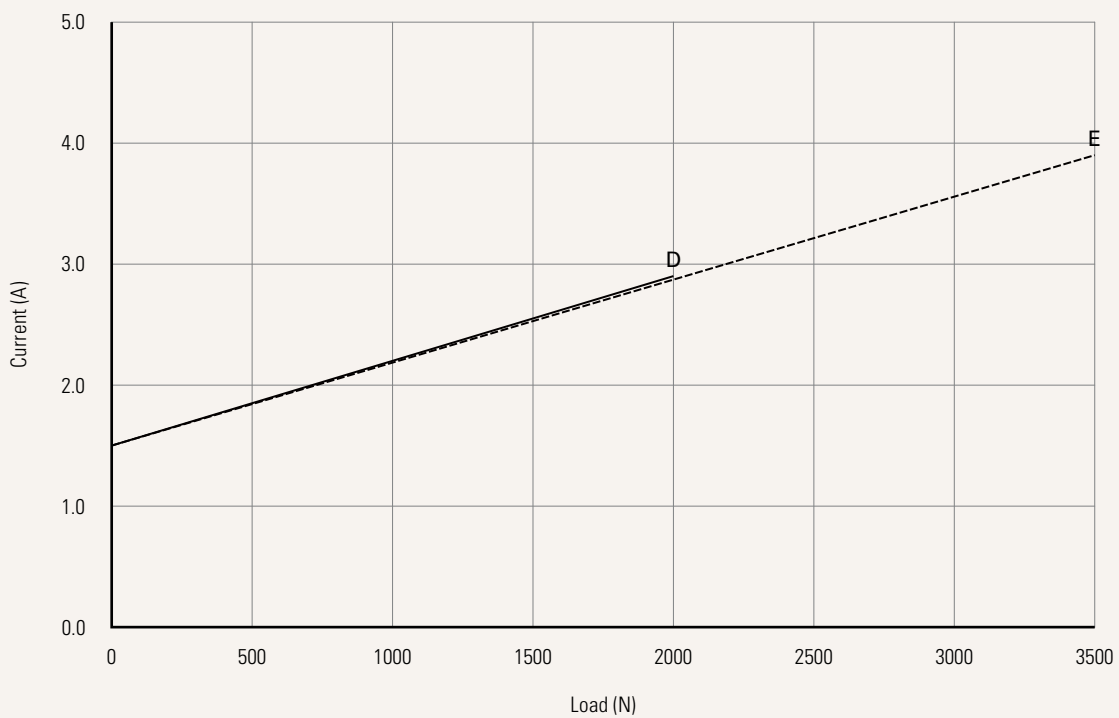

Performance Data (220V AC Motor)

Motor Speed (5200RPM, Duty Cycle 30%)

Speed vs. Load

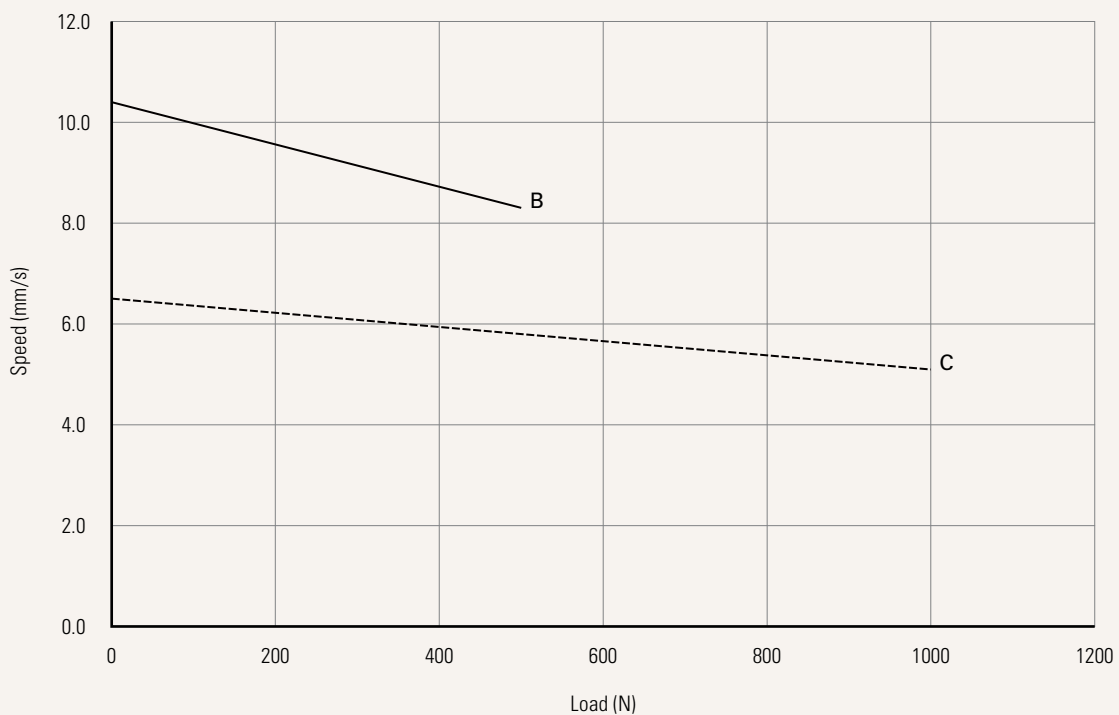

Current vs. Load

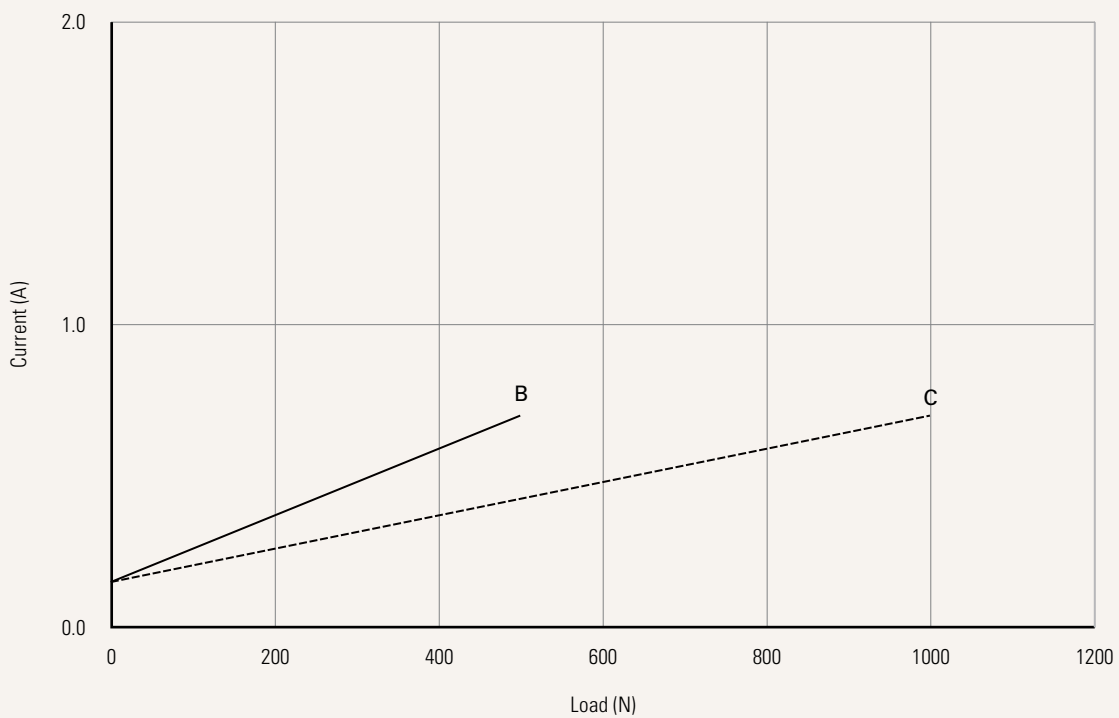

Performance Data (220V AC Motor)

Motor Speed (5200RPM, Duty Cycle 10%)

Speed vs. Load

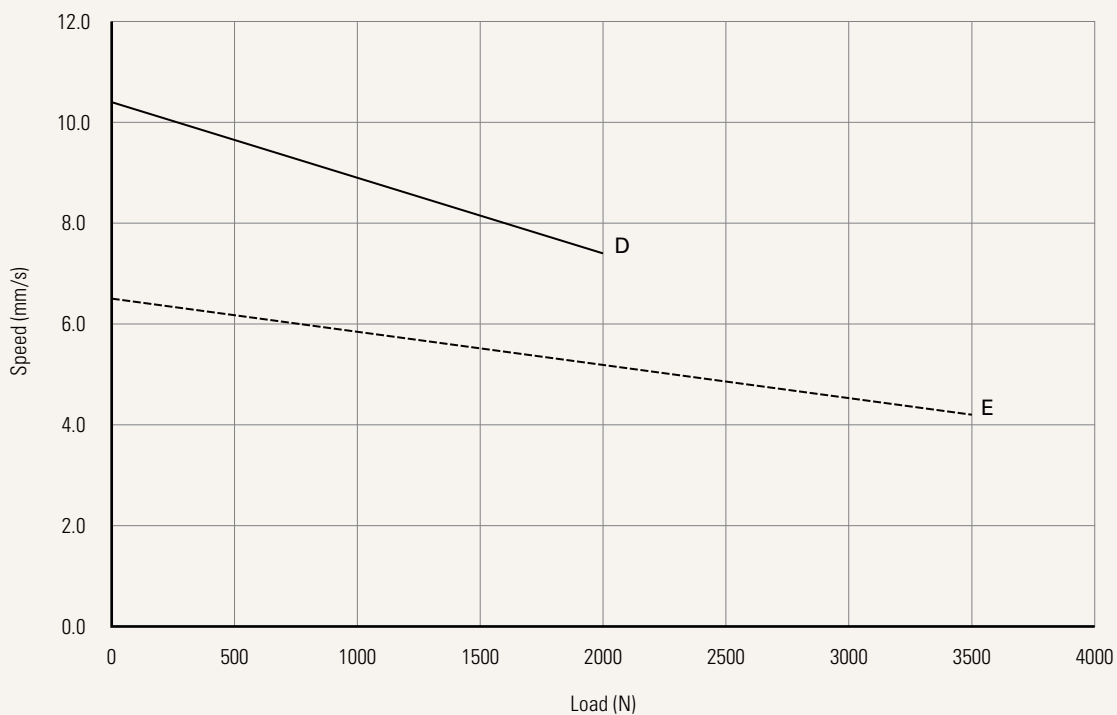

Current vs. Load

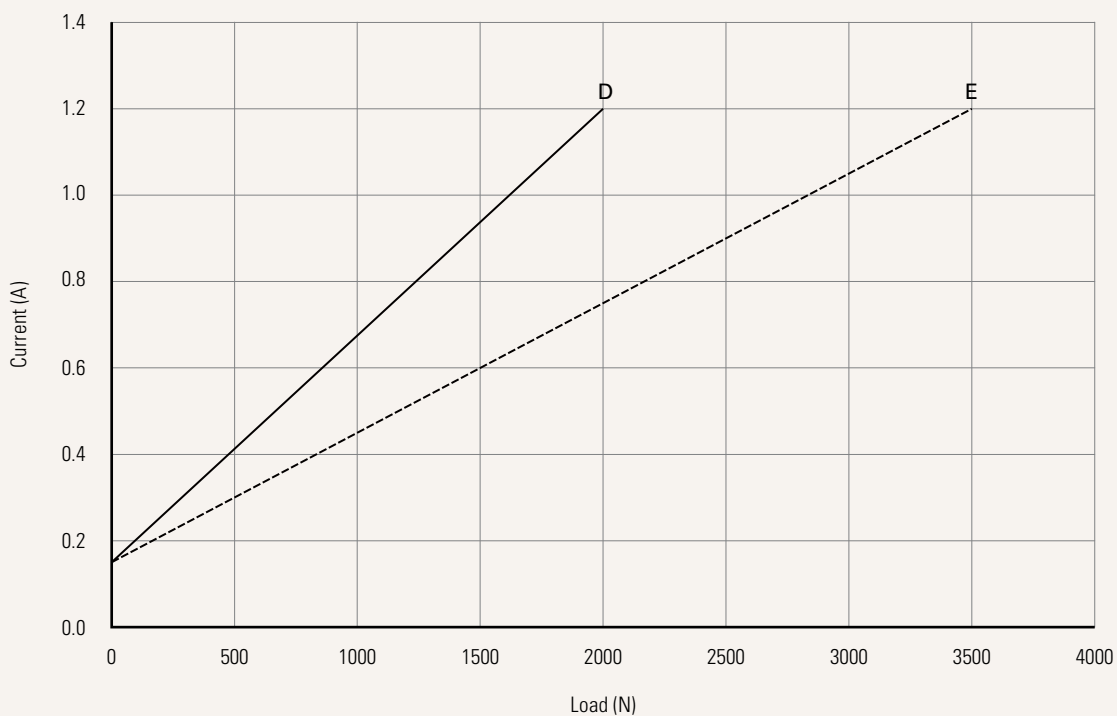

Voltage	1 = 12V DC	2 = 24V DC	U = 100-240V AC (50Hz)	
Load and Speed	See page 3			
Stroke (mm)	See page 3			
Retracted Length (mm)	See page 11			
Rear Attachment (mm)	0 = Without (choose outer tube adjustable attachment)			
Outer Tube Adjustable Attachment (Clamping Block)	0 = Without	2 = Hole ø8 (without rear attachment)		
	1 = Hole M8 (without rear attachment)			
	See page 11			
Trunnion Mount Bracket	0 = Without			
Front Attachment (mm)	B = Rod end bearing, hole 8.0	3 = Aluminum casting, no slot, hole 10.0		
	C = Rod end bearing, hole 10.0	7 = Aluminum CNC, U clevis, slot 6.2, depth 16.0, hole 6.4		
	1 = Aluminum casting, no slot, hole 6.4	8 = Aluminum CNC, U clevis, slot 6.2, depth 16.0, hole 8.0		
	2 = Aluminum casting, no slot, hole 8.0	9 = Aluminum CNC, U clevis, slot 6.2, depth 16.0, hole 10.0		
Direction of Rear Attachment (Counterclockwise)	0 = Without (When rear attachment is outer tube slide clamp block)	1 = 90°	2 = 0°	
	See page 12			
Color	1 = Black (Position B)	2 = Black (Position C)	3 = Pantone 428C (Position B)	4 = Pantone 428C (Position C)
IP Rating	1 = Without	2 = IP54	3 = IP66	
Special Functions for Spindle Sub-Assembly	0 = Without	1 = Safety nut		
Functions for Limit Switches	1 = Two switches at full retracted / extended positions to cut current			
	3 = Two switches at full retracted / extended positions to send signal			
	6 = Two switches at full retracted / extended positions to cut current + third one at end of stroke as window closed indicator switch			
	7 = Two switches at full retracted / extended positions to send signal + third one at end of stroke as window closed indicator switch			
Output Signal	0 = Without	2 = Hall sensor * 2	E = Embedded Hall sensor * 2 to MCU; the cable is without signal out	
Window Seal Mechanism	0 = Without	1 = With		
Connector	B = Tinned Lead			
P1 Cable (Big Hole)	0 = Without	1 = Standard (DC)	3 = US (AC)	
	Note: please contact TiMOTION before making an order			
P1 Cable Length (mm)	0 = Without	2 = 1000	4 = 2000	
	1 = 500	3 = 1500	5 = 5000	
P2 Cable (Small Hole)	0 = Without	1 = Standard (DC)	3 = US (AC)	
	Note: please contact TiMOTION before making an order			
P2 Cable Length (mm)	0 = Without	2 = 1000	4 = 2000	
	1 = 500	3 = 1500	5 = 5000	
T-Smart Version	0 = Without		C = T-Smart synchronization version	
Bus Interface Board	0 = Without		L = Parallel sync function without outer control box	
Push / Pull Application	1 = Push application		2 = Pull application	

System	1 = Single application	2 = Sync, 2 actuators in system	
Set Upper Stroke Limitation by Software	Full stroke, Standard default value		
Set Lower Stroke Limitation by Software	0000, standard default value		
Extension Soft Stop Length	0 = No deceleration, standard default value		
Retraction Soft Stop Length	0 = No deceleration, standard default value		
Over Current Protection	P = Cut current for over current protection, extend and retract over current protection value are standard default value Note: please contact TiMOTION before making an order		
Extend Speed	0 = PWM output 100%, standard default value 9 = PWM output 90% 8 = PWM output 80%	7 = PWM output 70% 6 = PWM output 60% 5 = PWM output 50%	
Retract Speed	0 = PWM output 100%, standard default value 9 = PWM output 90% 8 = PWM output 80%	7 = PWM output 70% 6 = PWM output 60% 5 = PWM output 50%	
Extension Soft Stop	1 = 1 second, standard default value	2 = 2 seconds	3 = 3 seconds
Retraction Soft Stop	1 = 1 second, standard default value	2 = 2 seconds	3 = 3 seconds

Retracted Length (mm)

1. Calculate $A+B = Y$
2. Retracted length needs to $\geq \text{Stroke}+Y$

The total Retracted length calculated must be equal or longer than below minimum value.

A.

Front Attach.	Outer Tube
B	+206
C	+212
1, 2, 3	+169
7, 8, 9	+182

B.

Stroke (mm)	
20~150	-
151~200	+2
201~250	+2
251~300	+2
301~350	+12
351~400	+22
401~450	+32
451~500	+42

1. When Choosing the Outer Adjustable Attachment

Voltage	DC		AC	
	Without	With	Without	With
T-smart				
B	218	308	438	438
C	224	314	444	444
1, 2, 3	181	271	401	401
7, 8, 9	194	284	414	414

Outer Tube Adjustable Attachment (Clamp Block)

1 = Hole M8 (without rear attachment)

2 = Hole $\varnothing 8$ (without rear attachment)

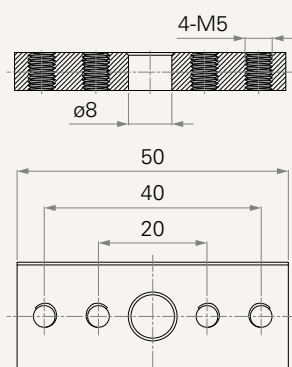
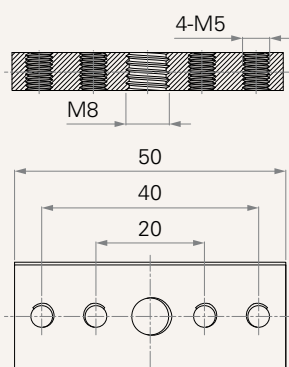

Front Attachment (mm)

B = Rod end bearing, hole 8.0

C = Rod end bearing, hole 10.0

1 = Aluminum casting, no slot, hole 6.4

2 = Aluminum casting, no slot, hole 8.0

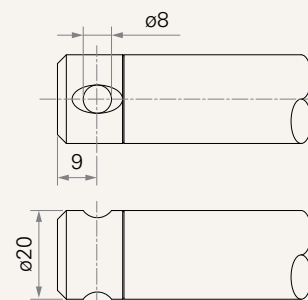
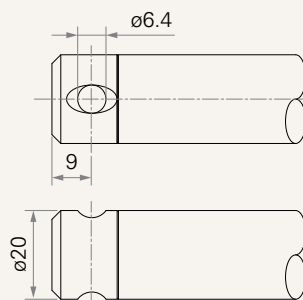
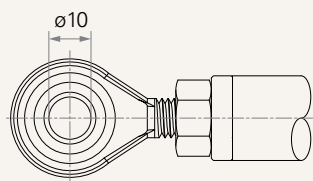
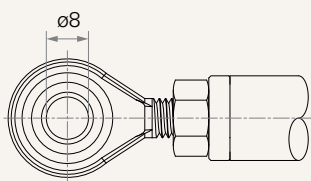

3 = Aluminum casting, no slot, hole 10.0

7 = Aluminum CNC, U clevis, slot 6.2, depth 16.0, hole 6.4

8 = Aluminum CNC, U clevis, slot 6.2, depth 16.0, hole 8.0

9 = Aluminum CNC, U clevis, slot 6.2, depth 16.0, hole 10.0

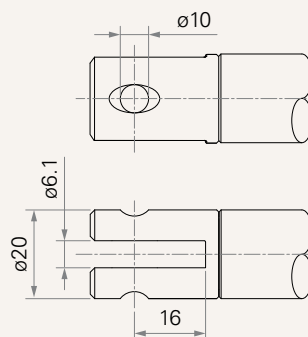
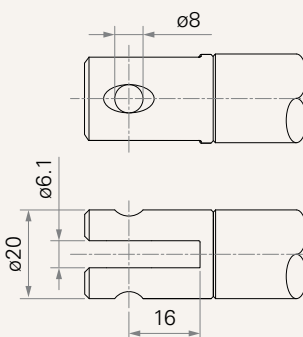
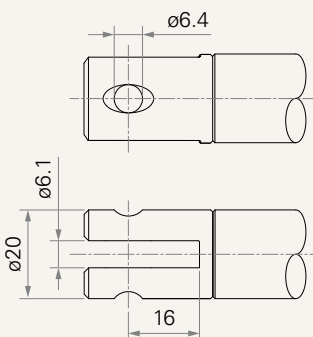
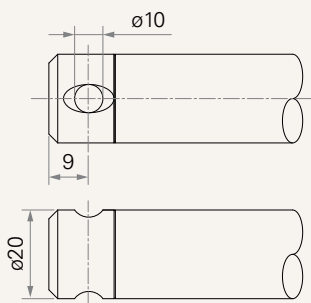

Direction of Rear Attachment (Counterclockwise)

0 = Without (When rear attachment is outer tube slide clamp block)

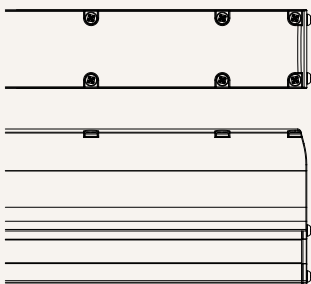

Terms of Use

The user is responsible for determining the suitability of TiMOTION products for a specific application. TiMOTION products are subject to change without prior notice.