

Brushless Edition - Rev. B

Elife-Drive HR Series

(ex H)



Application Reference Manual



Elife International S.r.l.

Via del Giglio, 4 - 57037 Portoferraio - LI

Isola d'Elba - Toscana - Italy

Tel: +39 0565 944121 Fax: +39 0565 945726

email: info@elifinternational.com

This manual is copyrighted of Elife International. All rights are reserved. This manual must not be copied in whole or in part, nor transferred to any other media or language, without express written permission of Elife International.

Technical Manual Version: **2.4**

Release Data: 07/12/2018

Contents

1	Overview	1
2	Installation and Wiring	5
2.1	Mounting Elife-Drive on-board	5
2.2	Connections	5
2.2.1	High Power Connections	6
2.2.2	Low Power Connections	8
2.3	Standard Wiring Diagrams and Wiring Instructions	11
2.3.1	Standalone Mode	11
2.3.2	PLC Mode	16
2.3.3	CAN Network Mode	20
2.3.4	RS232 Mode	24
2.4	Feedback Connector	27
2.4.1	Resolver	29
2.4.2	SinCos Encoder	30
2.4.3	Hall Sensor	30
2.4.4	Fa-Coder	31
2.4.5	Digital Absolute Angle Position	32
3	Configuration	33
3.1	Software Overview	33
3.2	Connect Elife-Drive to your PC	34
3.3	Import and Export Parameter Values	35
3.4	Change Programmable Parameters	35
3.4.1	Operating Mode and Controller Parameters	36
3.4.2	Motor and Acceleration Parameters	38
3.4.3	Throttle Parameters	39
3.4.4	CANopen [®] Parameters	39
3.4.5	Locked Parameters	40
3.4.6	Advanced Parameters	43
3.5	Auto-tuning Elife-Drive Parameters	46
3.5.1	Gain Parameters for closed-loop Current Control	46
3.5.2	Finding the Min and Max values for SinCos Encoder	47
3.5.3	Offset Resolver/SinCos	49

4	Monitoring Elife-Drive	51
4.1	LED Diagnostics	51
4.2	Reading Telemetry Data from Telemetry Panel	51
4.2.1	Alarm Indicators	54
4.2.2	Reset all Current Alarms	56
4.2.3	Digital I/O and Drive State Indicators	56
4.2.4	The Target Velocity/Torque Track Bar	58
4.3	Plot and Log Telemetry Data in Real-Time	59
5	Maintenance	61
A	Troubleshooting: Alarm Messages	63
B	Index of Programmable Parameters	71

List of Tables

1.1	The common features of all models of Elife-Drive H Series	2
1.2	An overview of the Elife-Drive H Series Models	3
2.1	A summary table of high-power connections, except the H4896-X-X Type.	7
2.2	Fuse size in accordance with the Elife-Drive Type.	7
2.3	The pins' description for the J1 - COMMAND connector.	8
2.4	Elife-Drive I/O definitions for Standalone Mode	12
2.5	Elife-Drive I/O definitions for PLC Mode	16
2.6	CAN bus address selector switch at the node set to 0.	17
2.7	Elife-Drive I/O definitions for Can Network Mode	20
2.8	Elife-Drive I/O definitions for RS232 Mode	24
2.9	Pinout Description of the J2 - FEEDBACK DB9 connector (See Figure 2.11) to connect a Resolver to your Elife-Drive.	29
2.10	Pinout Description of the J2 - FEEDBACK DB9 connector (See Figure 2.11) to connect a SinCos Encoder to your Elife-Drive.	30
2.11	Pinout Description of the J2 - FEEDBACK DB9 connector (See Figure 2.11) to connect a Hall Sensor to your Elife-Drive.	30
2.12	Pinout Description of the J2 - FEEDBACK VGA connector (See Figure 2.12) to connect a Fa-Coder to your Elife-Drive.	31
2.13	Pinout Description of the J2 - FEEDBACK VGA connector (See Figure 2.12) to connect a Digital Absolute Angle Position to your Elife-Drive.	32
4.1	Description of Digital I/O indicators in Telemetry Panel.	57

4.2	Plotting and logging telemetry data with Telemetry Panel.	60
B.1	Index of Elife-Drive Programmable Parameters in alphabetical order. .	71

Overview

Elife-Drive is the new family of drivers designed to drive the various types of low-voltage servomotors, specifically for use in battery powered devices.

The compact form was made possible thanks to the high efficiency of the design, manufactured with state-of-art electronic components.

Elife-Drive is highly configurable, a wide range of programmable parameters allow you to customize your system for your needs.

The main **key features** include:

- Designed to drive from 24 V to 96 V Brushless, Brushed and AC ServoMotors.
- The different types of feedback are supported: ***Absolute Resolver***, *SinCos Encoder*, *Hall Sensors*, *Sensorless*, *Incremental Encoder*, *Tachometer*.
- Advanced algorithms for predictive speed and torque control.
- CANopen[®] communication protocol¹: CiA[®] DS301 and CiA[®] DSP402 (Interface Profile Velocity, Torque Profile Mode and Profile Position Mode)
- Electromagnetic Holding Brake Output with DPR System (Dynamic Power Reduction)
- Telemetry of the Internal functions
- Integrated Fuse Holder (only up 80 V)
- European Conformity **CE**, and designed and tested in accordance with the *Electromagnetic compatibility* (EMC) emission [EN 61000-6-4] and immunity [EN 61000-6-2] standards.

¹ Elife International is a Member of CiA[®] - CAN in Automation

Specification:

- ✓ Four Quadrant Regenerative Operation
- ✓ Space Vector Modulation Technology
- ✓ Sinusoidal and Trapezoidal Commutation Methods
- ✓ Programmable Gain Setting
- ✓ Fully Configurable Velocity and Position Limits
- ✓ On-the-fly Mode and Gain Set Switching
- ✓ Emergency Deceleration Ramp and Emergency Input

Programmable Input/Output:

- ➔ **Two** High Powered Digital *Outputs*
- ➔ **One** 12-bit Analog *Input* 0 ÷ 10 V
- ➔ **Five** Digital *Inputs* Single Ended
- ➔ **Four** Digital *Outputs* Singled Ended

Table 1.1: The common features of all models of **Elife-Drive H Series**

	VALUE
PWM Operating Frequency:	6103 Hz
Digital Input Pin Voltage:	up to 36 V
Electrical Insulation at Heat Sink:	500 V (minimum)
Digital Output Pin Current:	up to 250 mA
Brake and Power Relay Pin Current:	up to 2 A
Digital Input Pin Current:	1.0 mA @24 V
Digital Output Pin Voltage:	From 6 to 30 V
Analog Input Voltage:	From 0 to 10 V
Package Environmental Rating:	IP 30
Weight	1.1 kg
Dimensions H x W x D:	144x100x72 mm (<i>Electrical Box Version</i>) 110x90x56 mm (<i>OEM Version</i>)

A broad range of models enable us to satisfy every requirements and to suggest the best solution for your system.

An overview of the **Elife-Drive H Series Models** is shown in Table 1.2. For other models, have a look at Elife-Drive S Series for *lower power* models or at Elife-Drive M Series for *higher power* models.

Table 1.2: An overview of the **Elife-Drive H Series Models**

DRIVER	CONTINUOUS RMS PHASE CURRENT *	MAXIMUM OUTPUT POWER	NOMINAL VOLTAGE SUPPLY (Operating Range)
H2448-2-X	up to 100 A	2 KW	48 V (18 Vmin - 70 Vmax)
H2424-3-X	up to 150 A	3 KW	24 V (18 Vmin - 35 Vmax)
H2436-3-X	up to 150 A	3 KW	36 V (18 Vmin - 55 Vmax)
H2448-3-X	up to 150 A	3 KW	48 V (18 Vmin - 70 Vmax)
H4896-6-X	up to 150 A	6 KW	96 V (43 Vmin - 150 Vmax)

* The value of the maximum **continuous** RMS Phase current is ensured with an appropriate heat sink



Figure 1.1: Elife-Drive series H enables you to drive from 24 V to 96 V Brushless, Brushed and AC ServoMotors. It's available in two configurations: (a) *Electrical Box* with container and in (b) *OEM Version* for integrating into motor housing.

Product Identification Label

Most of information about your Elife-Drive - such as *serial number*, model, customer information, *etc* - can be found on a label located on the front of the Elife-Drive (see figure below). Some of these information might be requested when you contact the technical assistance.

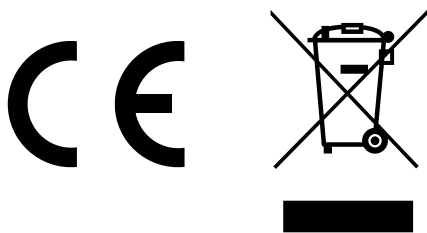
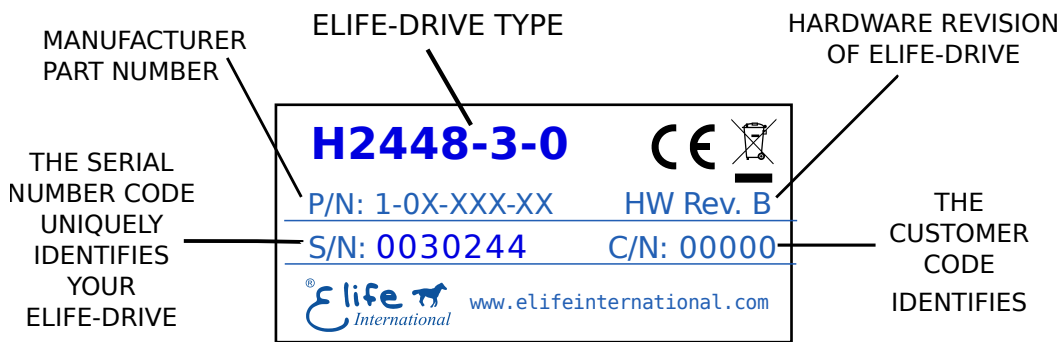

Compliance with the EU regulatory requirement for electrical and electronic equipment. When your Elife-Drive is no more usable, can't be treated as generic garbage, but must be disposed of at a collection point for recycling of electrical and electronic equipment, in compliance with the **WEEE** regulation (Waste of Electrical and Electronic Equipment).

Installation and Wiring

2.1 Mounting Elife-Drive on-board

The Elife-Drive can be mounted in any orientation, but you must choose a location in order to keep the controller **clean** and **dry**, away from sunlight, water and ice. When you mount the Elife-Drive on-board you should **ensure an effective heat dissipation** between the Elife-Drive and the vehicle surface.



Tips and Advice

A thermal grease can be used on the rear side of the Elife-Drive heatsink to improve the heat exchange between Elife-Drive and the vehicle surface.

Elife-Drive has a LED light on the front of the device that visually explains what the driver is doing (see Section 4.1), if you want it to be visible you should take this into consideration before choosing the location where your Elife-Drive will be mounted.



Warning

In order to ensure the proper functioning of the Elife-Drive you must keep the controller clean and dry and ensure an effective heat exchange between the Elife-Drive and the vehicle surface.

2.2 Connections

Elife-Drive on the front, see Figure 2.1, has different types of connectors:

High Power Connections The three-phase alternating-current generated by Elife-Drive is supplied through the **U,V,W** terminals. The **F+,B-** are the positive¹ and negative terminals to connect to your battery.

Low Power Connections A 24-pin male connector (**J1 - COMMAND**) for low power logic control.

¹For **H4896-X-X** Type you must connect an external fuse to the **B+** terminal, see Section 2.2.1.

Feedback Connections A 9-pin female low power connector (**J2 - FEEDBACK**) to connect your feedback board.

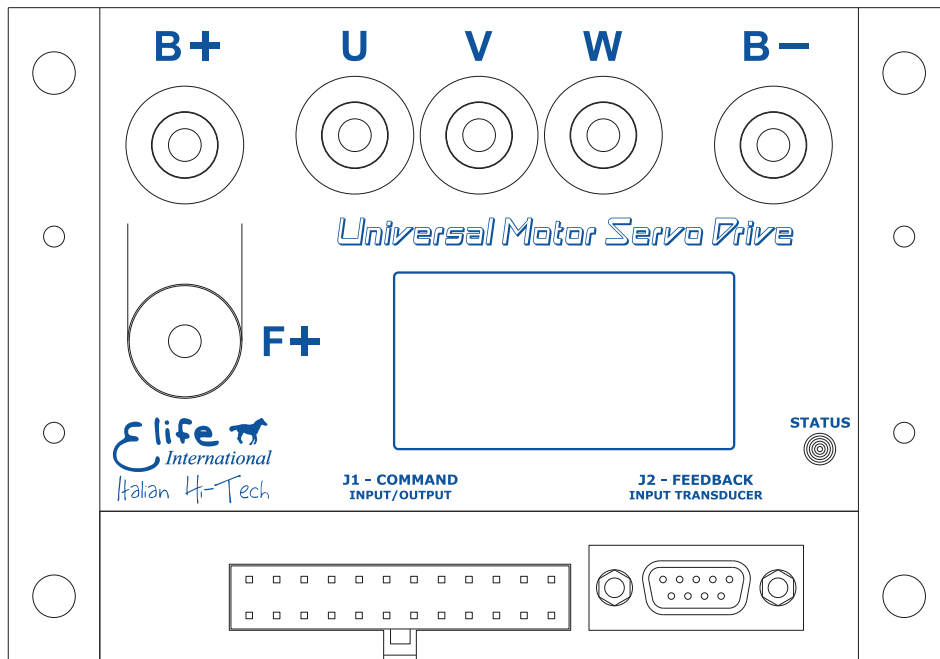

Figure 2.1: Elife-Drive has different types of connectors that can be categorized in: High Power Connections (**U,V,W,F+,B-,B+**), Low Power Connections (**J1 - COMMAND**) and Feedback Connector (**J2 - FEEDBACK**).

2.2.1 High Power Connections

High power connections are provided by: 3-phase supply terminals (**U,V,W**) and two terminals for battery connections (**F+** or **B+,B-**).

In order to connect correctly Elife-Drive, you should use the following instructions:

1. Except the **H4896-X-X** Type, you must mount an appropriately sized fuse (See Table 2.2) between **F+** and **B+** terminal to avoid damage to the controller.

Note

All Elife-Drive models, except the **H4896-X-X** Type, have a fuse already installed.

2. Connect the **battery positive** cable to the **F+** terminal and the **battery negative** cable to the **B-** terminal.

➤ For **H4896-X-X** Type you must connect an external fuse to the **B+** terminal (see Table 2.2 and the Wiring Diagrams).

Table 2.1: A summary table of high-power connections, except the H4896-X-X Type.

TERMINAL	CONNECT TO
F+	Battery positive terminal to the fuse link
B+	Fuse terminal
B-	Battery negative terminal
U,V,W	U, V, and W motor phases

3. Connect the U, V, and W motor phases to the 3-phase supply terminals (U,V,W).

 **Note**

The **tightening torque** for high-power connections must be **5.5 N·m**.

 **Warning**

Make sure when you connect the high-power cables that the feedback cable passes as far as possible from the power cables and they are not located close to each other, in order to avoid electromagnetic interference.

Table 2.2: Fuse size in accordance with the Elife-Drive Type.

ELIFE-DRIVE TYPE	FUSE RATING
H2448-2	40 A
H2424-3	100 A
H2436-3	70 A
H2448-3	50 A
H4896-6	70 A

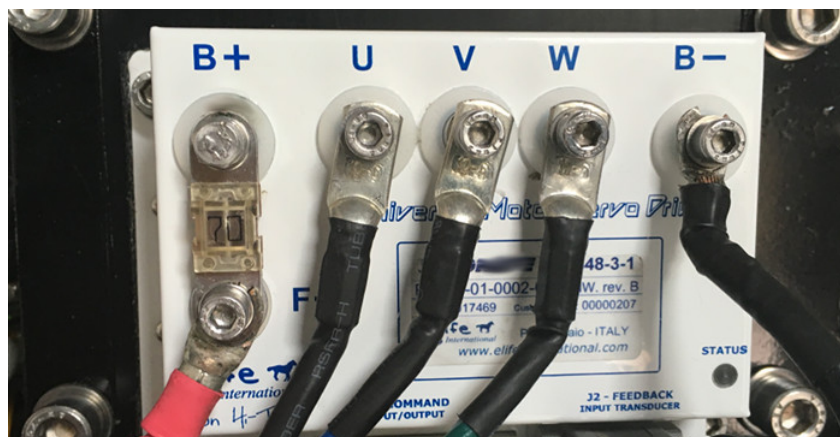

Figure 2.2: Elife-Drive H Series - High-power connections.

2.2.2 Low Power Connections

The low power logic control connections are provided by a 24-pin male connector (**J1 - COMMAND**). The pins' description is given in Table 2.3.

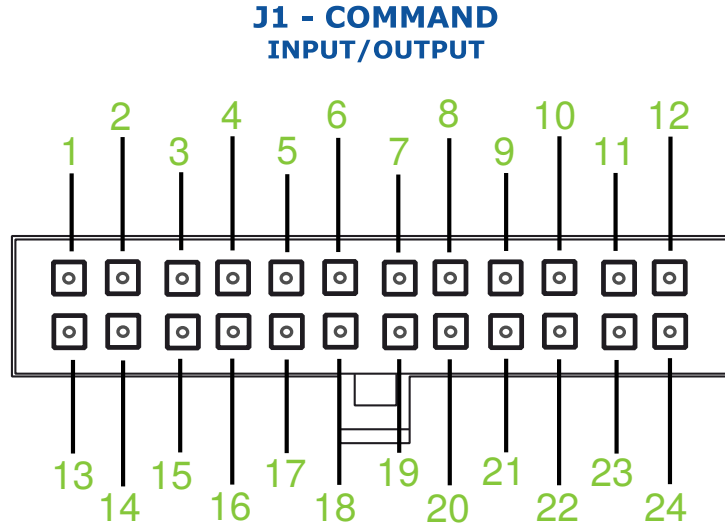

Table 2.3: The pins' description for the **J1 - COMMAND** connector.

PIN	I/O TYPE	DESCRIPTION	OPERATING RANGE
1	IN1	Digital input 1	$V_{MAX} = 36V$, High > 11 V
2	IN3	Digital input 3	$V_{MAX} = 36V$, High > 11 V
3	IN5	Digital input 5	$V_{MAX} = 36V$, High > 11 V
4	+24V INPUT	Power supply for output pins, it should be protected with 4A delayed fuse, type T	From 6 to 30 V
5	BRAKE	Brake supply with programmable dynamic power reduction	Output Voltage in according to the Input voltage on PIN 4 $I_{MAX}=2 A$
6	LINE CONTACTOR OUT	Driver main contactor output	Output Voltage in according to the Input voltage on PIN 4 $I_{MAX}=2 A$
7	OUT1	Digital output 1	Output Voltage in according to the Input voltage on PIN 4 $I_{MAX}=250 mA$
8	PWR POT	Speed potentiometer supply output	$V_{OUT}= 10 V$ $I_{OUT}=100 mA$

Continued on next page ...

... continued from previous page

PIN	I/O TYPE	DESCRIPTION	OPERATING RANGE
9	ANALOG GND	Analog Common / Potentiometer Low Input	/
10	CAN-	CAN_L bus line (dominant low)	Standard CAN
11	TX RS232	TX output, it is used to communicate with RS232 in order to realize Telemetry panel	Standard RS232
12	SERIAL GND	RS232 Common, it is used to communicate with RS232 in order to realize Telemetry panel	/
13	KEY (+BATT)	Internal logic circuits power supply, it should be protected with 1A delayed fuse, type T	From 18 to 80V (Only for H4896-X-X Type: From 43 to 160V)
14	IN2	Digital input 2	$V_{MAX} = 36\text{ V}$, High > 11 V
15	IN4	Digital input 3	$V_{MAX} = 36\text{ V}$, High > 11 V
16	SERVICE	Do not use	/
17	OUT2	Digital Output 2	Output Voltage in according to the Input voltage on PIN 4 $I_{MAX}=250\text{ mA}$
18	OUT3	Drive fault alarm output, it changes its current state whenever an alarm is present. See Section 3.4.1, Pag. 37	Output Voltage in according to the Input voltage on PIN 4 $I_{MAX}=250\text{ mA}$
19	OUT4	Encoder emulator, single phase	Output Voltage in according to the Input voltage on PIN 4 $I_{MAX}=250\text{ mA}$
20	-BATT	Common ground, it should be connected to the negative terminal of battery	/
21	AIN / WIPER POT	Analog input / Wiper input for throttle	From 0 to +10V From 0 to +5V
22	CAN+	CAN_H bus line (dominant high)	Standard CAN
23	GND CAN	CAN bus common	/
24	RX RS232	RX Input, it is used to communicate with RS232 in order to realize Telemetry panel	Standard RS232

Concluded

**Note**

The digital inputs have over-voltage protection up to battery voltage and the analog input up to 26 V.

2.3 Standard Wiring Diagrams and Wiring Instructions

This section contains standard wiring diagrams to be used to connect your **Elife-Drive H Series** on your system. The following wiring diagrams cover only the standard operating mode in which the Elife-Drive works to drive a Brushless Servomotor.

It's also possible to connect two or more Elife-Drive together for specific application (e.g: steering wheel control) and drive different types of servomotor. These advanced installations will not be dealt with in the present manual.



Warning

The following wiring diagrams and operating instructions should be read carefully and completed before wiring your Elife-Drive up on your system. The wiring diagram must be chosen in according to the operating mode (PLC, Standalone, CAN, RS323) that suits your needs.



Note

For **H4896-6-X Type** you should mount an external fuse, see Section 2.2.1.

2.3.1 Standalone Mode

The *Standalone* mode is designed to drive your motor with only two inputs: a *throttle* and a *emergency input*.

Other optional inputs can be used to extend the functionality of this operating mode (See Table 2.4).

For the correct functioning of this operating mode, special attention must be paid to choose the correct value of *Analog Input* (See Section 3.4.3) in according to the throttle characteristics.



Note

If you've installed a 0-10V or 0-5V throttle the rotation direction of the motor should be given through the FORWARD and the BACKWARD input.

When **throttle is put to neutral position** - before bridge activation - you can indicate the speed mode (FAST/SLOW input).

Table 2.4: Elife-Drive I/O definitions for **Standalone Mode**.

PIN	I/O TYPE	NAME	DESCRIPTION	
1	IN1	CRUISE	Rising Edge Signal = Enable/Disable Active or Disable the Cruise Control if a Rising Edge Signal is detected	Optional
14	IN2	FAST/SLOW	High = Slow mode, Low = Fast mode. This input is processed <i>only before</i> bridge activation	Optional ^a
2	IN3	FORWARD	High = Forward, Low = Stop (only if BACKWARD is low)	Optional ^b
		BACKWARD	High = Backward, Low = Stop. This input is only processed if FORWARD input is low.	Optional ^b
15	IN4	REVERSE	High = Active, Low = Inactive. If it's active, invert the positive/negative range of throttle.	Optional ^c
3	IN5	EMERGENCY	Emergency input should always be supplied, otherwise Elife-Drive stops motor rotation and unlocks motor brake.	Mandatory
7	OUT1	REVERSE	It is the output to connect to buzzer, it gets high when the rotation direction is backward.	
17	OUT2	STATUS	It gets steady high when motor is running and blinking when motor is stopped. It's low when there is an alarm.	
18	OUT3	ALARM	Alarm output, it changes its current state whenever an alarm is present. See Section 3.4.1, Pag. 37	

^a **Mandatory** if you want to switch between Fast and Slow mode, see Section 3.4.2.

^b **Mandatory** only for 0–10V or 0-5V throttle, see Section 3.4.3

^c Only valid for 0–5-10V or 0-2.5-5V throttle, see Section 3.4.3

Tips and Advice

You can setup accurately the levels of your throttle in the **Tuning Tab** by the **Analog adjustment in Standalone** parameters.

The **Fast** and **Slow** modes are designed to meet two different purposes:

Slow mode It's programmable so that the vehicle indoor moves slowly with accurate operation.

Fast mode It allows a faster velocity for outdoor long distance path.

It's scheduled both the configuration of the maximum motor velocity and the maximum velocity at Slow mode (See Section 3.4.2).

The Standalone Mode has a **Cruise Control**. The controller - when the Cruise Control is activated by a Rising Edge Signal on IN1 - read the actual target velocity by the throttle state and keep this velocity stable also when the throttle is released. The Cruise Control are disabled by the following actions:

- A Rising Edge Signal on IN1
- If the Emergency Input is unsupplied.
- For any Alarm Occurs.

The **wiring diagram** for standalone mode is shown in Figure 2.3 for any Elife-Drive H Series Type, except the **H4896-X-X** Type (Figure 2.4).

Standalone Mode - Wiring Diagram

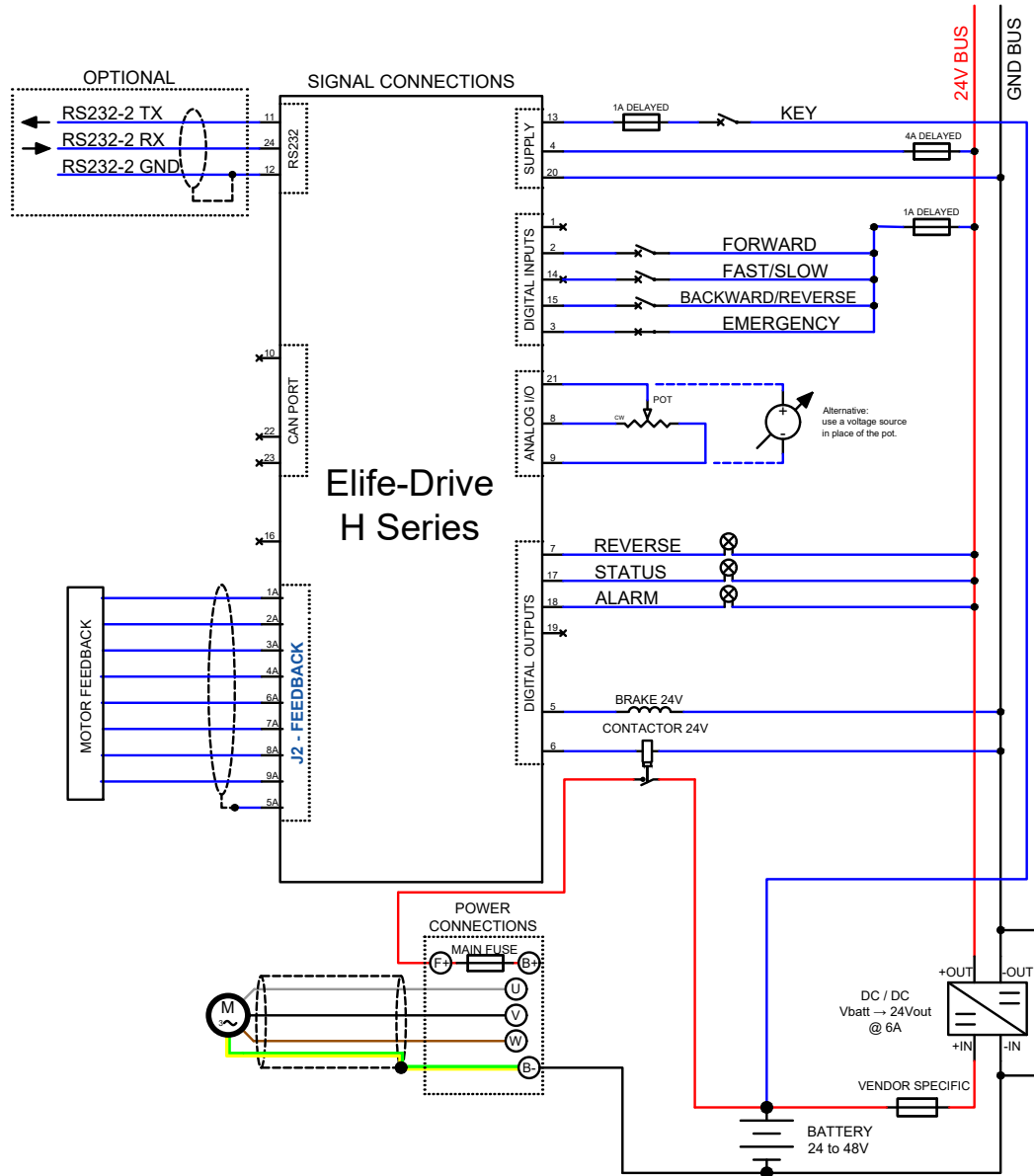

Figure 2.3: The wiring diagram to connect your Elife-Drive H Series - except the H4896-X-X Type - to your system in Standalone Mode.

Standalone Mode - Wiring Diagram [H4896-X-X Type]

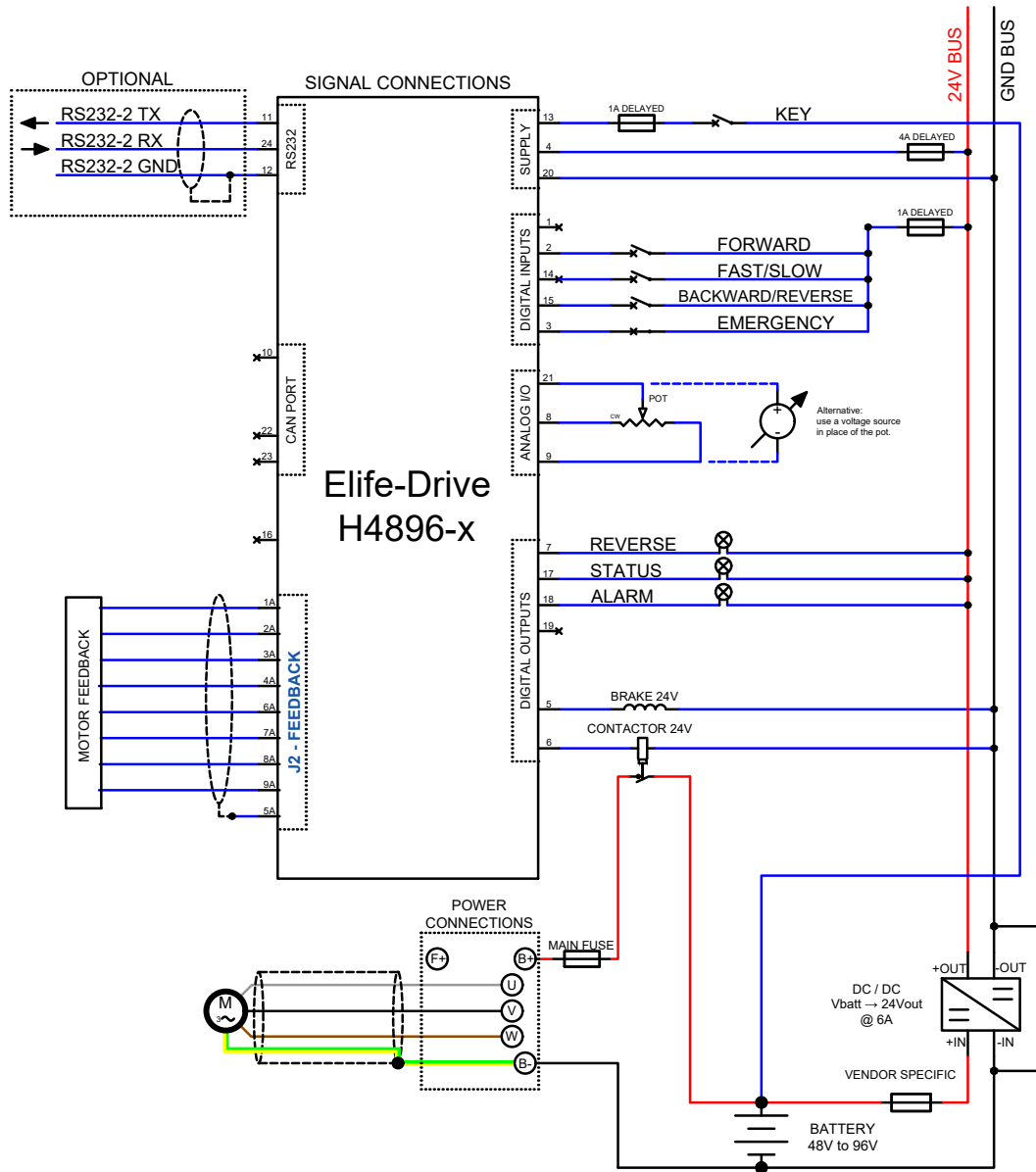

Figure 2.4: The wiring diagram to connect your Elife-Drive H4896-X-X to your system in Standalone Mode.

2.3.2 PLC Mode

The *PLC mode* is a flexible, self-contained operating mode for automatic vehicles (AGV).

The details of inputs and output of this operating mode are shown in Table 2.5.

Table 2.5: Elife-Drive I/O definitions for PLC Mode

PIN	I/O TYPE	NAME	DESCRIPTION	
1	IN1	CCW OVERTRAVEL	High = Active Overtravel for CCW rotation, Low = Inactive Overtravel	Optional ^a
		CRUISE	Rising Edge Signal = Enable/Disable Active or Disable the Cruise Control if a Rising Edge Signal is detected	Optional ^b
14	IN2	CW OVERTRAVEL	High = Active Overtravel for CW rotation, Low = Inactive Overtravel	Optional ^a
2	IN3	DIR	High = Clockwise, Low = Counterclockwise	Optional ^c
15	IN4	RUN / STOP	High = Run, Low = Stop	Mandatory
3	IN5	EMERGENCY	Emergency input should always be supplied, otherwise Elife-Drive stops motor rotation and unlocks motor brake.	Mandatory
18	OUT3	ALARM	Alarm output, it changes its current state whenever an alarm is present. See Section 3.4.1, Pag. 37	

^a It is processed as overtravel input if *overtravels* are enabled by Telemetry panel, see Section 3.4.6.

^b It is processed as cruise control if *overtravels* are disabled by Telemetry panel, see Section 3.4.6.

^c **Mandatory** only for 0–10V or 0-5V throttle.

For the correct functioning of this operating mode, special attention must be paid to choose the correct value of *Analog Input* (See Section 3.4.3) in according to the throttle characteristics.



Note

If you've installed a 0-10V or 0-5V throttle the rotation direction of the motor should be given through DIR input.

When the RUN / STOP input gets high the brake is unlocked and the motor starts to spin-up. If *overtravels* are enabled by the Telemetry panel (see Section

3.4.6) Elife-Drive will stop the motor when one of two over-travel inputs (CCW OVERTRAVEL and CW OVERTRAVEL) will get high.

Otherwise if the overtravels are disabled by the Telemetry panel, the **IN1** can be use to active the **Cruise Control**.

The Standalone Mode has a **Cruise Control**. The controller - when the Cruise Control is activated by a Rising Edge Signal on IN1 - read the actual target velocity by the throttle state and keep this velocity stable also when the throttle is released. The Cruise Control are disabled by the following actions:

- A Risign Edge Signal on IN1
- If the Emergency Input is unsupplied.
- For any Alarm Occours.

In this configuration it is also possible to read the most important information through **CAN** bus. In this case the **IN4** and **IN5** input could be used as shown in Table 2.6.

Table 2.6: CAN bus address selector switch at the node set to 0.

PIN	I/O TYPE	NAME	DESCRIPTION
15	IN4	CAN ADR0	It could be used as CAN address selector 0
3	IN5	CAN ADR1	It could be used as CAN address selector 1

In case that the CAN address is set to **0** through Telemetry panel, after switch-on it is possible to appoint the node-ID depending on two digital inputs: CAN ADR0 and CAN ADR1, in the following way:

CAN NODE	INPUT CONFIGURATION	
1	CAN ADR1 → GND	CAN ADR0 → GND
2	CAN ADR1 → GND	CAN ADR0 → +24V
3	CAN ADR1 → +24V	CAN ADR0 → GND
4	CAN ADR1 → +24V	CAN ADR0 → +24V

PLC Mode - Wiring Diagram

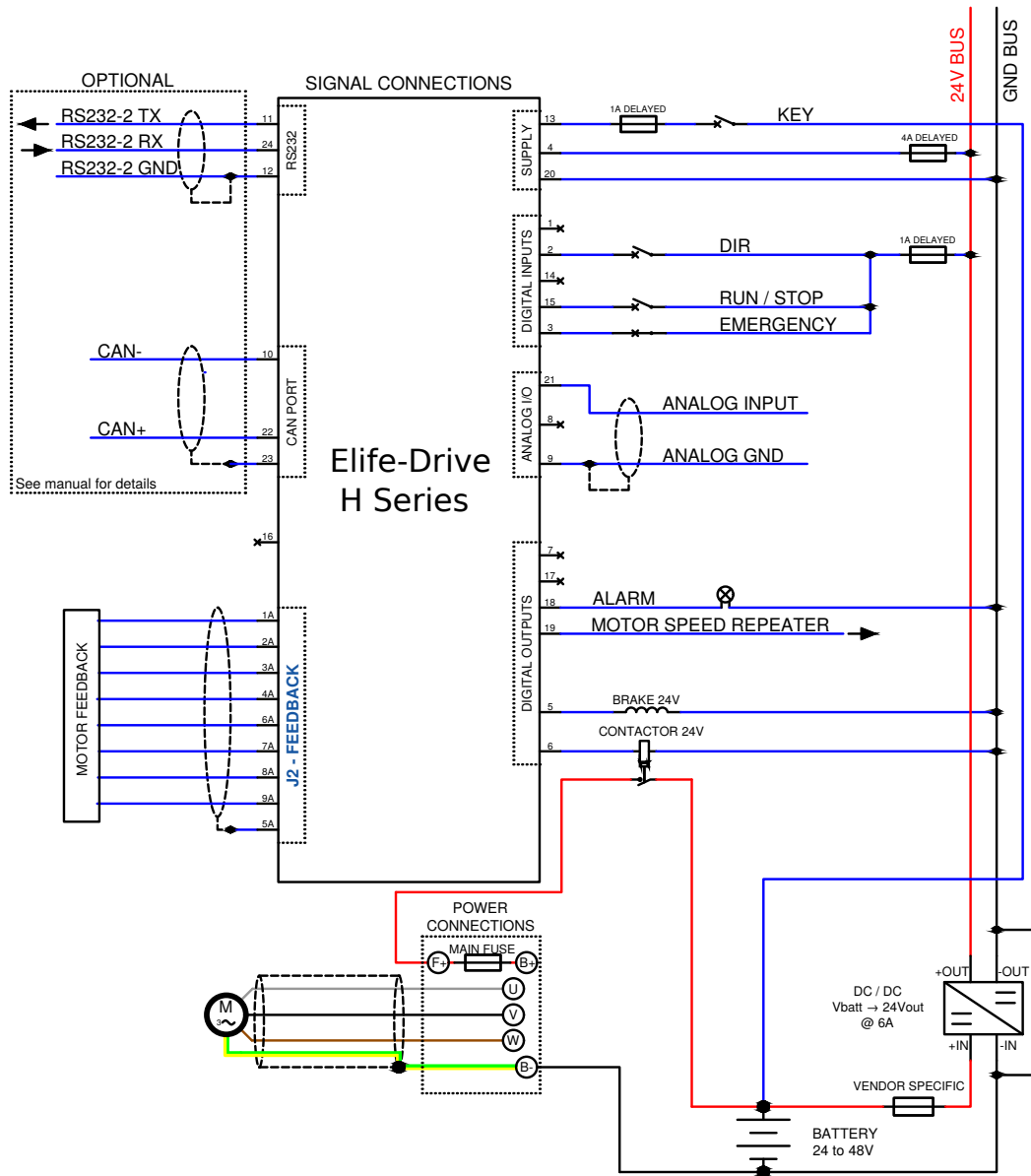

Figure 2.5: The wiring diagram to connect your **Elife-Drive H Series** - except the H4896-X-X Type - to your system in **PLC Mode**.

PLC Mode - Wiring Diagram [H4896-X-X Type]

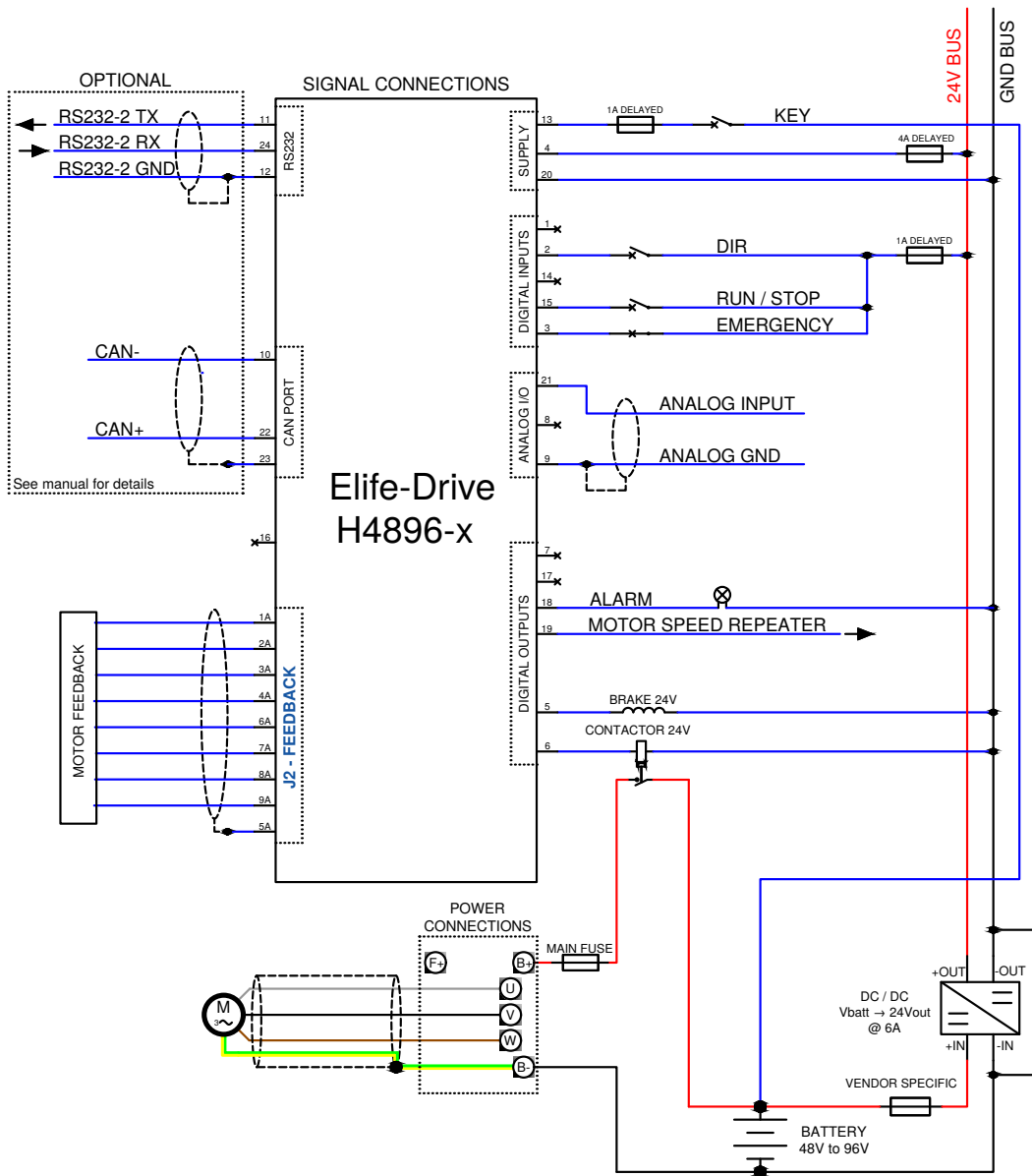

Figure 2.6: The wiring diagram to connect your Elife-Drive H4896-X-X to your system in PLC Mode. In the wiring diagram Resolver is used as Feedback System, for other feedback systems see Section 2.4.

2.3.3 CAN Network Mode

In **CAN Network** mode you can control your motor through CANopen[®] bus protocol. For further information about CANopen[®] protocol, please refer to CiA[®] DSP402 protocol (version 3.0.1.15) and UNDRIVE CANopen[®] Manual.

A description of the inputs and outputs connections for this operating mode is shown in Table 2.7

Table 2.7: Elife-Drive I/O definitions for **Can Network** Mode

PIN	I/O TYPE	NAME	DESCRIPTION	
1	IN1	BWD	It could be used as negative limit switch	Optional
14	IN2	FWD	It could be used as positive limit switch	Optional
2	IN3	HOME SENSOR	It could be used as home switch	Optional
15	IN4	CAN ADRO	It can be used as CAN address selector 0	Optional
3	IN5	CAN ADR1/ EMERGENCY	It could be used as CAN address selector 1 / Emergency input should always be supplied, otherwise Elife-Drive stops motor rotation and unlocks motor brake	Optional / Mandatory ^a
18	OUT3	ALARM	Alarm output, it changes its current state whenever an alarm is present. See Section 3.4.1, Pag. 37	

^a If the CAN address is set by Telemetry panel, the **IN5** input becomes an **Emergency Input**.

In this operating mode is needed to set the correct CANopen[®] parameters via Telemetry Panel (See Section 3.4.3).



Note

If the CAN Address is set by Telemetry panel - and different from **0** - the CAN address selector inputs (CAN ADRO, CAN ADR1) are ignored to set the CAN Address. The **IN5** input becomes an **Emergency Input** and **will must be supplied**, otherwise Elife-Drive stops motor rotation and unlocks motor brake

In case that the CAN address is set to **0** through Telemetry panel, after switch-on it is possible to appoint the node-ID depending on two digital inputs: CAN ADRO and CAN ADR1, in the following way:

CAN Network Mode - Wiring Diagram

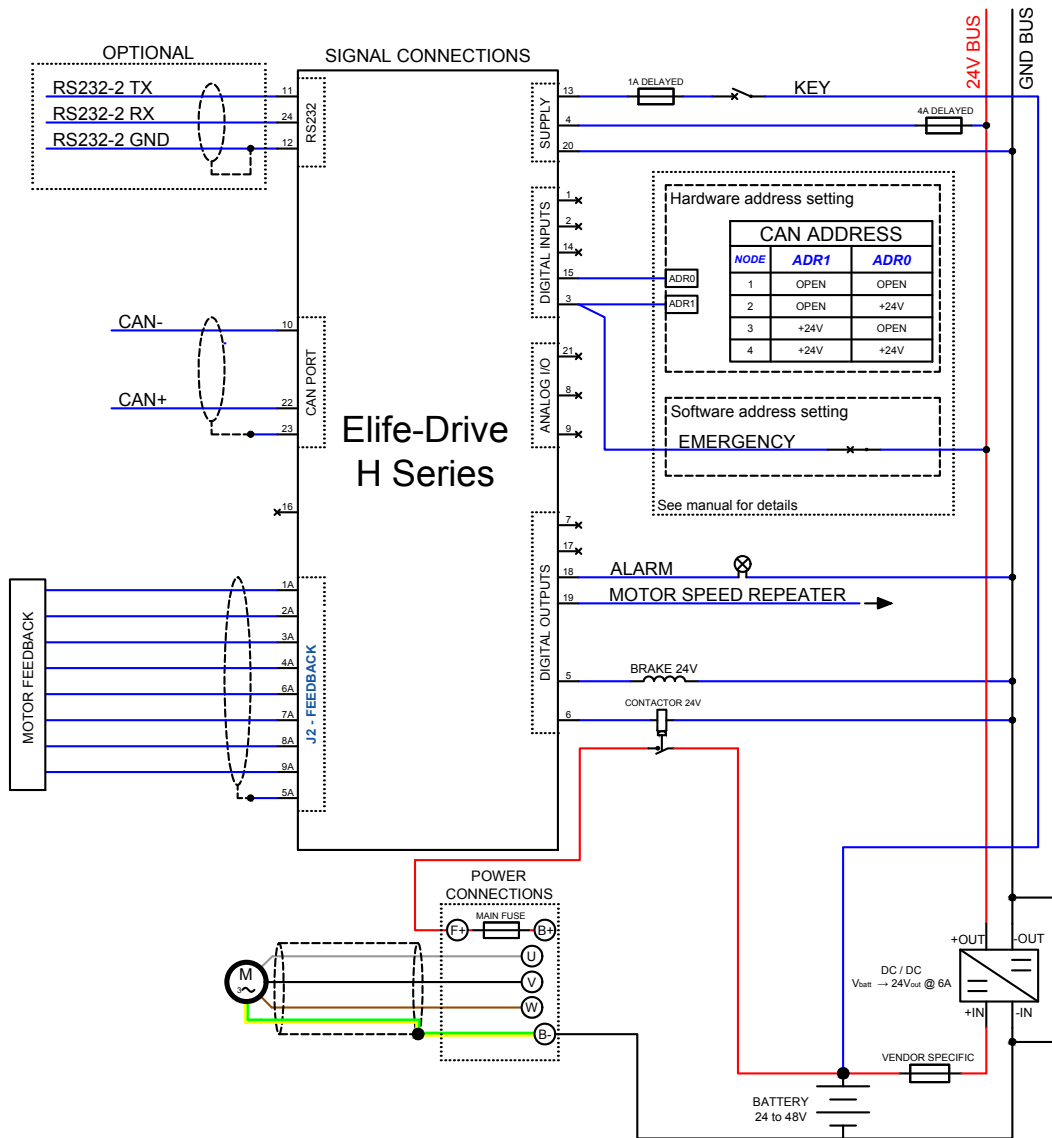

Figure 2.7: The wiring diagram to connect your **Elife-Drive H Series** - except the H4896-X-X Type - to your system in **CAN Network**.

CAN Network Mode - Wiring Diagram [H4896-X-X Type]

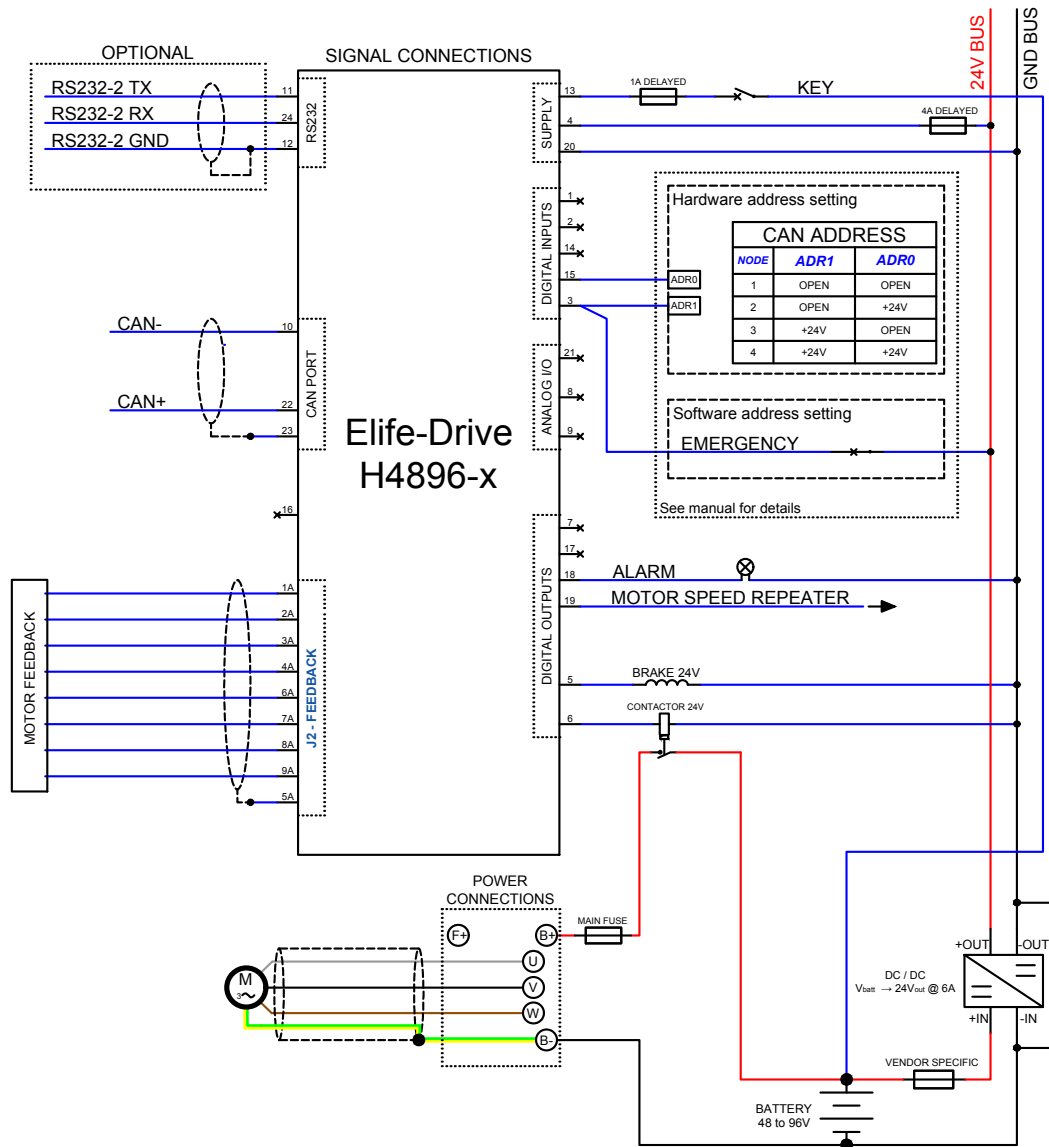
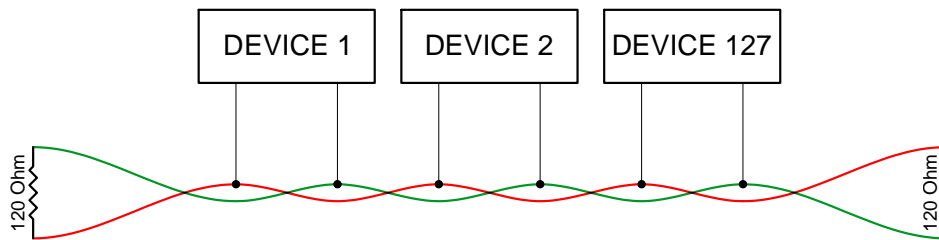

Figure 2.8: The wiring diagram to connect your Elife-Drive H4896-X-X to your system in CAN Network Mode.

CAN NODE	INPUT CONFIGURATION	
1	CAN ADR1 → GND	CAN ADR0 → GND
2	CAN ADR1 → GND	CAN ADR0 → +24V
3	CAN ADR1 → +24V	CAN ADR0 → GND
4	CAN ADR1 → +24V	CAN ADR0 → +24V

Please pay particular attention when wiring CANopen[®] connection: at both ends there must be a 120Ω resistor and the bus length must be the following:

BIT RATE	BUS LENGTH
1 Mbit/s	25 m
500 Kbit/s	100 m
250 Kbit/s	250 m
125 Kbit/s	100 m



2.3.4 RS232 Mode

The RS232 Mode allows you to drive your motor via Telemetry Panel (See Chapter 4) or send the control commands² to the Elife-Drive through the RS232 protocol. This operating mode can be useful for testing your motor, without worrying about other devices (e.g: potentiometer) or other controllers (e.g: PLC) (See Section 4.2.4). See Figure 2.9 for wiring diagrams for this operating mode and Table 2.8 for a description of inputs and outputs.

Table 2.8: Elife-Drive I/O definitions for **RS232** Mode.

PIN	I/O TYPE	NAME	DESCRIPTION
3	IN5	EMERGENCY	Emergency input should always be supplied, otherwise Elife-Drive stops motor rotation and unlocks motor brake. Mandatory
18	OUT3	ALARM	Alarm output, it changes its current state whenever an alarm is present. See Section 3.4.1, Pag. 37

²For further information, see **Elife-Drive - RS232 Communication Protocol** document

RS232 Mode - Wiring Diagram

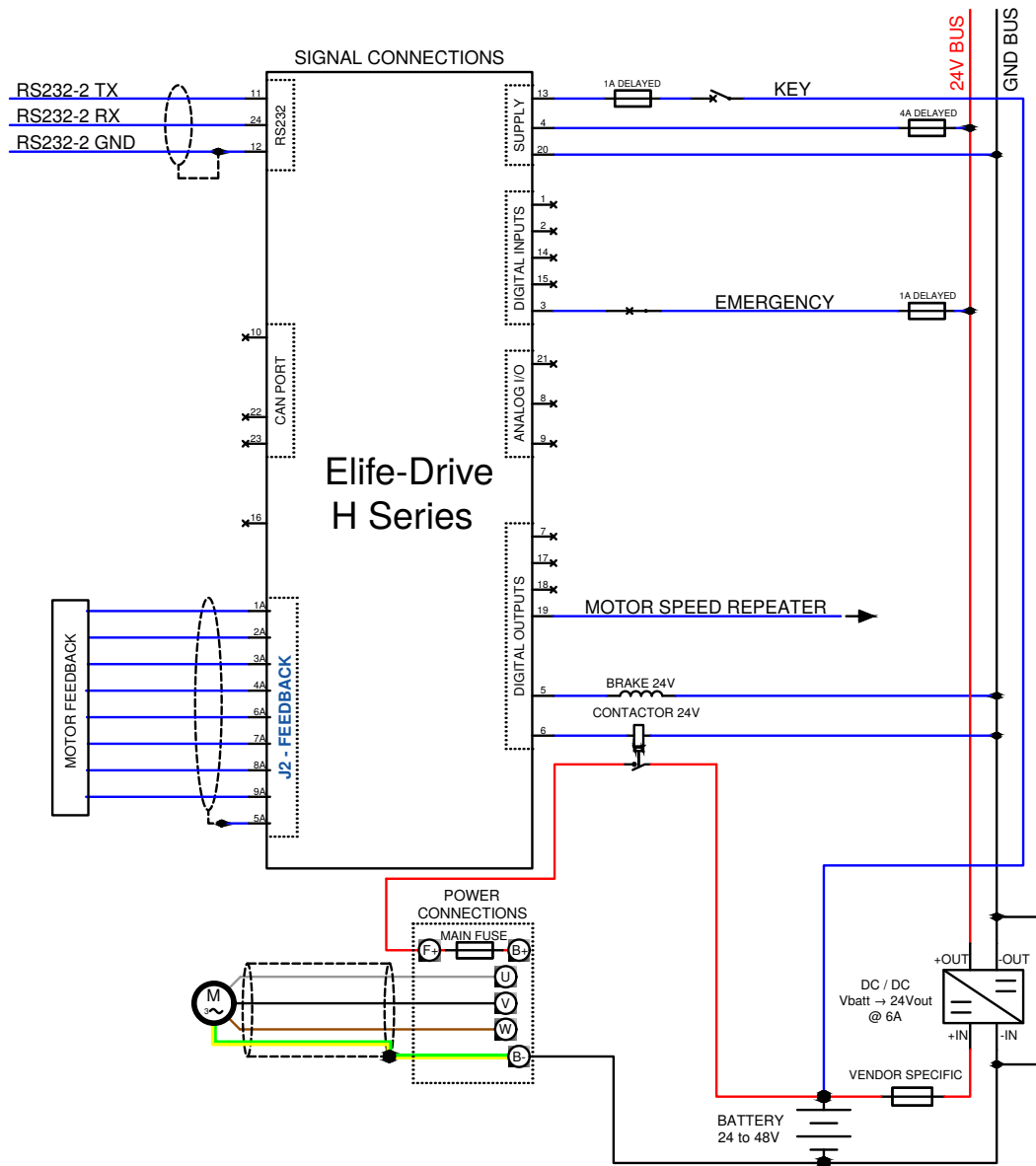

Figure 2.9: The wiring diagram to connect your **Elife-Drive H Series** - except the H4896-X-X Type - to your system in **RS232 Mode**. To connect the feedback system see Section 2.4.

RS232 Mode - Wiring Diagram [H4896-X-X Type]

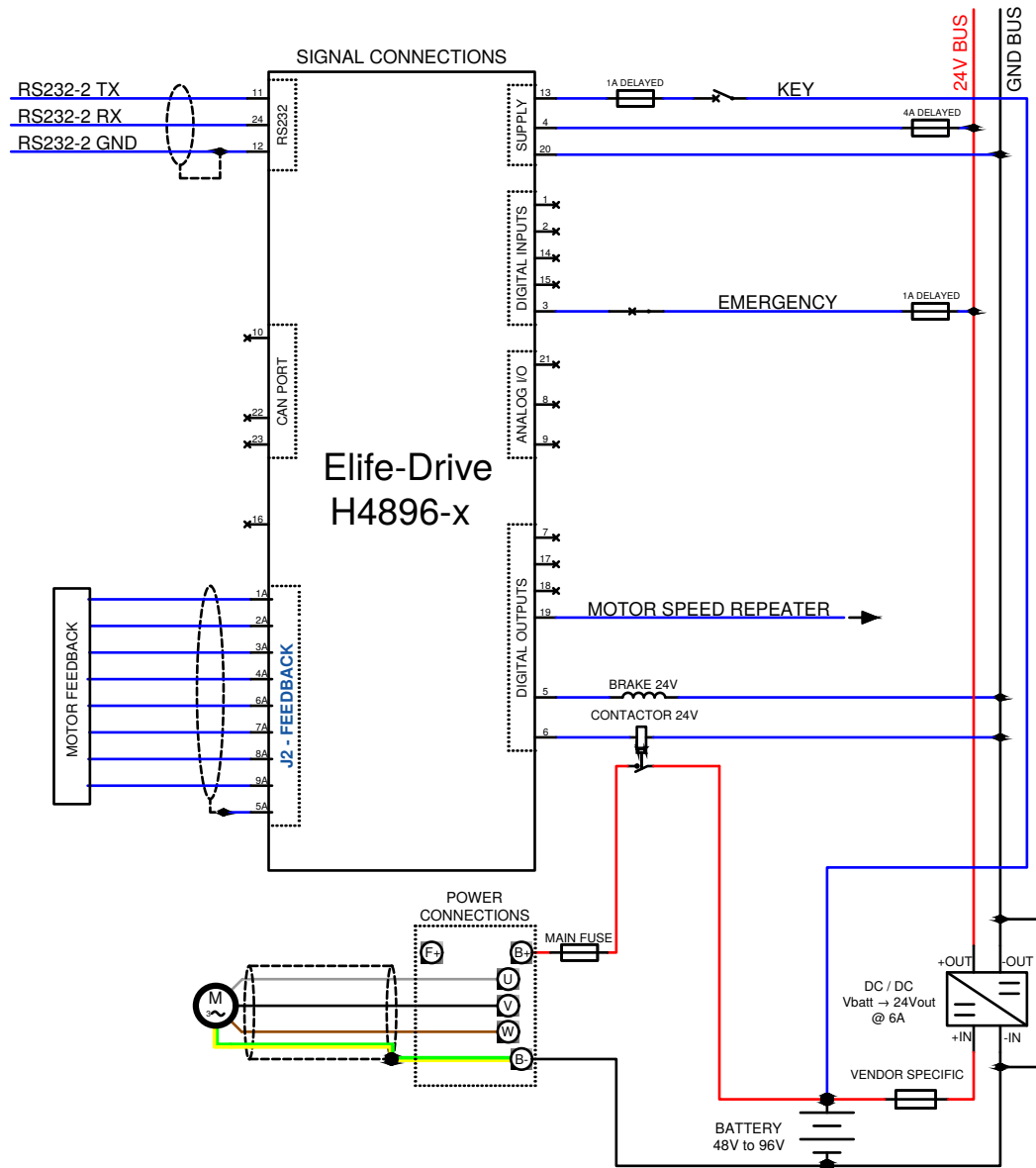

Figure 2.10: The wiring diagram to connect your Elife-Drive H4896-X-X to your system in RS232 Mode. To connect the feedback system see Section 2.4.

2.4 Feedback Connector

The feedback connector (**J2 - FEEDBACK**) can be of two types in accordance with the Elife-Drive model chosen and the type of Motor Feedback supported.



Note

The pinout descriptions and type of **J2 - FEEDBACK** connector depends on the type of feedback board mounted on your motor and the Elife-Drive Type chosen.

DB9 Connector:

A female 9-pin connector used to connect the following Motor Feedback:

Resolver: See Section 2.4.1.

SinCos Absolute Encoder: See Section 2.4.2.

Hall Sensor: See Section 2.4.3.

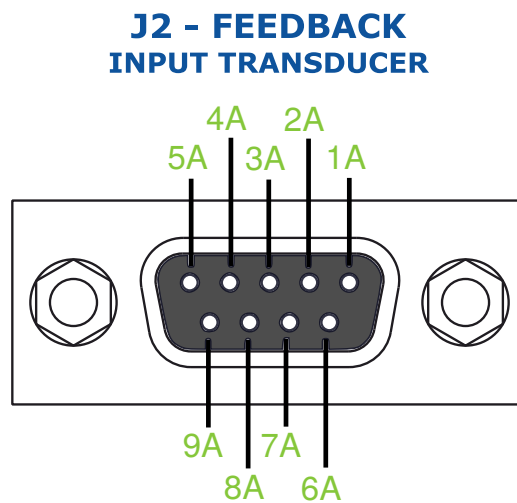

Figure 2.11: Pin Assignments of the **J2 - FEEDBACK** female connector on Elife-Drive (DB9 Connector).

VGA Connector:

A female 15-pin connector used to connect the following Motor Feedback:

Fa-coder: See Section 2.4.4.

Digital Absolute Encoder: SSI or SPI Connection, see Section 2.4.5.

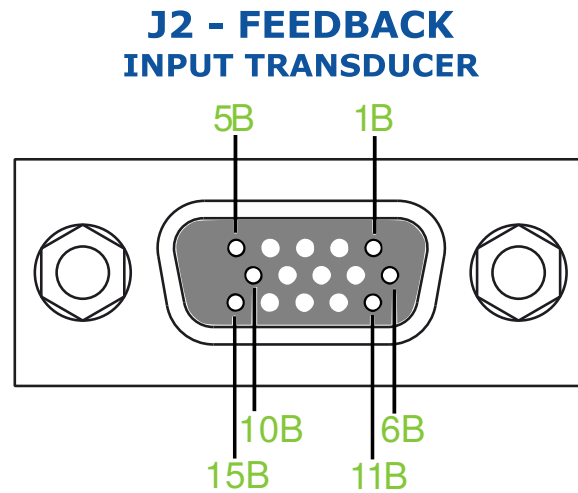

Figure 2.12: Pin Assignments of the **J2 - FEEDBACK** female connector on Elife-Drive (VGA Connector).



Warning

Make sure when you connect the high-powered connections that the feedback cable passes as far as possible from the power cables, and they are not located close to each other, in order to avoid electromagnetic interference.

2.4.1 Resolver

Table 2.9: Pinout Description of the **J2 - FEEDBACK** DB9 connector (See **Figure 2.11**) to connect a **Resolver** to your Elife-Drive.

PIN	I/O TYPE	DESCRIPTION	OPERATING RANGE	
1A	DRIVING SIGNAL -	The negative Driving signal	From -5 to +5 V	Mandatory
2A	THERMAL	Temperature sensor	/	Optional ^a
3A	SIN-	Negative Sine	From -4 to +4 V	Mandatory
4A	COS-	Negative Cosine	From -4 to +4 V	Mandatory
5A	INNER SHIELD	Connect to the cable shield	/	Mandatory
6A	DRIVING SIGNAL +	The positive Driving signal	From -5 to +5 V	Mandatory
7A	SIN+	Positive Sine	From -4 to +4 V	Mandatory
8A	THERMAL	Temperature sensor	/	Optional ^a
9A	COS+	Positive Cosine	From -4 to +4 V	Mandatory

^a **Mandatory** only if you've selected Thermistor, KTY83/122 or KTY84/130 as *Temperature probe type* (See Pag. 45)

For example, a possible connection³ if your motor has a **M23 feedback motor connector** :

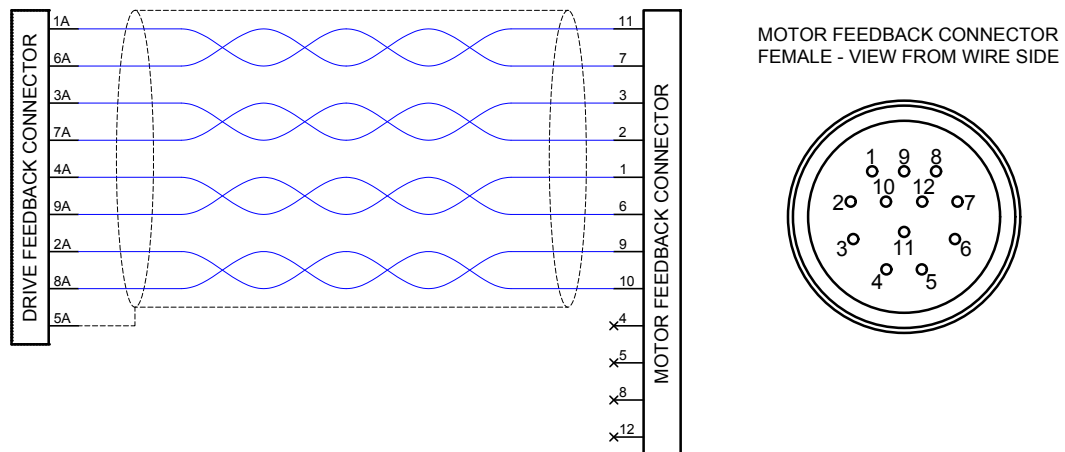

Figure 2.13: Wiring Diagram to connect your **Resolver** board to Elife-Drive if your motor has a **M23 feedback motor connector** (a possible connection).

³The M23 pins out are specified in the Motor Technical Datasheet.

2.4.2 SinCos Encoder

Table 2.10: Pinout Description of the **J2 - FEEDBACK** DB9 connector (See Figure 2.11) to connect a **SinCos Encoder** to your Elife-Drive.

PIN	I/O TYPE	DESCRIPTION	OPERATING RANGE	
1A	+5V	SinCos Supply	V = +5V	Mandatory
2A	SIN	Sine Signal	From 0 to +5V	Mandatory
3A	COS	Cosine Signal	From 0 to +5V	Mandatory
4A	THERMAL	Temperature sensor	/	Optional ^a
6A	GND	Common Ground	/	Mandatory
7A	INNER SHIELD	Connect to the cable shield	/	Mandatory
9A	THERMAL 2	Temperature sensor	/	Optional ^a

^a **Mandatory** only if you've selected Thermistor, KTY83/122 or KTY84/130 as *Temperature probe type* (See Pag. 45)

2.4.3 Hall Sensor

Table 2.11: Pinout Description of the **J2 - FEEDBACK** DB9 connector (See Figure 2.11) to connect a **Hall Sensor** to your Elife-Drive.

PIN	I/O TYPE	DESCRIPTION	OPERATING RANGE	
1A	+5V	Hall sensors supply	/	Mandatory
2A	THERMAL	Temperature sensor	/	Optional ^a
3A	H3	Hall Sensor 3	From +5 to +24V	Mandatory
4A	H2	Hall Sensor 2	From +5 to +24V	Mandatory
5A	H1	Hall Sensor 1	From +5 to +24V	Mandatory
6A	GND	Hall Sensor Ground	/	Mandatory
7A	GND	Hall Sensor Ground	/	Mandatory
8A	THERMAL	Temperature sensor	/	Optional ^a
9A	GND	Hall Sensor Ground	/	Mandatory

^a **Mandatory** only if you've selected Thermistor, KTY83/122 or KTY84/130 as *Temperature probe type* (See Pag. 45)

2.4.4 Fa-Coder

Table 2.12: Pinout Description of the **J2 - FEEDBACK** VGA connector (See Figure 2.12) to connect a **Fa-Coder** to your Elife-Drive.

PIN	I/O TYPE	DESCRIPTION	OPERATING RANGE	
1B	U	Hall Sensor U	From 0 to +5 V	Mandatory
2B	W	Hall Sensor W	From 0 to +5 V	Mandatory
3B	A	Encoder Channel A	From 0 to +5 V	Mandatory
4B	Z	Encoder Index Z	From 0 to +5 V	Mandatory
5B	GND	Common Ground	/	Mandatory
6B	U	Complementary Hall U	From 0 to +5 V	Mandatory
7B	V	Hall Sensor V	From 0 to +5 V	Mandatory
8B	A\	Complementary Channel A	From 0 to +5 V	Mandatory
9B	B	Encoder Channel B	From 0 to +5 V	Mandatory
10B	THERMAL	Temperature sensor	/	Optional ^a
11B	V\	Complementary Hall V	From 0 to +5 V	Mandatory
12B	W\	Complementary Hall W	From 0 to +5 V	Mandatory
13B	B\	Complementary Channel B	From 0 to +5 V	Mandatory
14B	B\	Complementary Index Z	From 0 to +5 V	Mandatory
15B	+5 V	Feedback Supply	V = +5 V	Mandatory

^a **Mandatory** only if you've selected Thermistor, KTY83/122 or KTY84/130 as *Temperature probe type* (See Pag. 45). Connect the other side of the thermal probe to the GND Pin (5B)

Note

The channels or the Hall Sensors may be indicated differently in function of Fa-Coder Feedback chosen. Read carefully the Motor Feedback Datasheet for a proper connection.

2.4.5 Digital Absolute Angle Position

Table 2.13: Pinout Description of the **J2 - FEEDBACK** VGA connector (See **Figure 2.12**) to connect a **Digital Absolute Angle Position** to your Elife-Drive.

PIN	I/O TYPE	DESCRIPTION	OPERATING RANGE	
1B	-	Don't use	-	-
2B	MOSI-	Negative of MOSI Signal	From 0 to +5 V	Optional ^a
3B	DATA-	Negative of Data Line Input	From 0 to +5 V	Mandatory ^a
4B	CLK-	Negative of Clock Signal	From 0 to +5 V	Mandatory
5B	GND	Common Ground	/	Mandatory
6B	THERMAL	Temperature sensor	/	Optional ^b
7B	-	Don't use	-	-
8B	MOSI+	MOSI Signal for SPI	From 0 to +5 V	Optional ^a
9B	Data+	Data Line Input from Sensor	From 0 to +5 V	Mandatory ^a
10B	CLK+	Clock Signal generated by Elide-Drive	From 0 to +5 V	Mandatory
11B	THERMAL	Temperature sensor	/	Optional ^b
12B	CS SPI	Chip Select for SPI	From 0 to +5 V	Optional ^a
13B	-	Don't use	-	-
14B	-	Don't use	-	-
15B	+5 V	Feedback Supply	V = +5 V	Mandatory

^a **Mandatory** only if you use a SPI Sensor.

^b **Mandatory** only if you've selected Thermistor, KTY83/122 or KTY84/130 as *Temperature probe type* (See Pag. 45)

^c In case of SPI Sensor, the DATA signals are also called MISO.



Note

The Elife-Drive is compatible with a wide range of Motor Feedback that use SSI or SPI as protocol communication.

Configuration

This chapter covers what you need to know to configure your Elife-Drive MR and MP Series via *Telemetry Panel*.



Warning

This part of the manual assumes that Elife-Drive was wired up correctly by following methods described in Chapter 2.

Telemetry Panel allows the adjustment of a wide range of parameters through the USB port in order to customize the vehicle's performance characteristics. To install Telemetry Panel you would simply double-click on *Setup.exe* file and following the instructions in the setup assistant.

After the installation, you can select your preferred language¹ and temperature scale - Celsius or Fahrenheit - from the list that appears under *Setup* menu.



Note

Before setting your Elife-Drive, make sure that you've the latest version of Software (Telemetry Software), Firmware and Application Reference Manual. You can find the latest version on our [website](#).

3.1 Software Overview

Software is organized in tabs according to the main functions:

Telemetry In this tab real-time telemetry data are displayed in easy-to-read format. You can also look at variables over time, both in graphical form and as data files.

Programmable Parameters In Programmable Parameters tab you can configure main parameters of Elife-Drive, import and export them in CFG format.

¹In order to display Chinese Unicode characters, user needs a Unicode Window or Unicode-compatible controls. User may also need to ensure that his Regional Settings are set up to support far eastern text/fonts.

Advanced Advance Tab includes some more programmable parameters to control your driver.

Autotuning The gain parameters for closed-loop current control and offset value of Resolver/SinCos can be estimated in Autotuning tab.

Car EV Mode Only activated for Elife-Drive M Series. It will not be dealt with in the present manual.

Steering Mode Steering Mode is an advanced operating mode of Elife-Drive. For more information, see the *Steering Mode* manual.

3.2 Connect Elife-Drive to your PC

In order to connect your Elife-Drive to Telemetry Panel, you should connect it to PC and wait for *USB* port recognition. After *USB* port recognition, you can launch Telemetry Panel and click on *Connection* menu (Figure 3.1).

Connect button permits to start communication toward the select *USB* port.



Note

Telemetry panel automatically creates a list of available *USB* port. It's then necessary to choose the suitable port where Elife-Drive is connected.

After connection, Telemetry Panel loads parameters from Elife-Drive allowing you to change them.

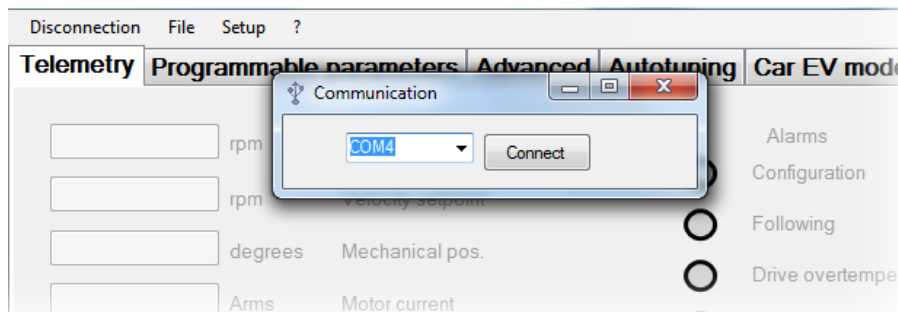

Figure 3.1: Connect your Elife-Drive to Telemetry Panel by *USB* port

3.3 Import and Export Parameter Values

After connecting your Elife-Drive to PC you can easily *import* or *export* (save) parameter values from and to *.cfg* file by *Telemetry Panel*.

- In order to **import** parameters from file and download them on to Elife-Drive:
 1. Move to *Programmable Parameters* tab.
 2. Select the *File* Menu and click on *Open* option.
 3. Select the desired *.cfg* file and wait for the progress bar to get completely green (Figure 3.2).
- Parameter values can also be **exported** to a *.cfg* file:
 1. Move to *Programmable Parameters* tab.
 2. Select the *File* menu and click on *Save*.
 3. Enter a descriptive name in the file name box and click *Save*.

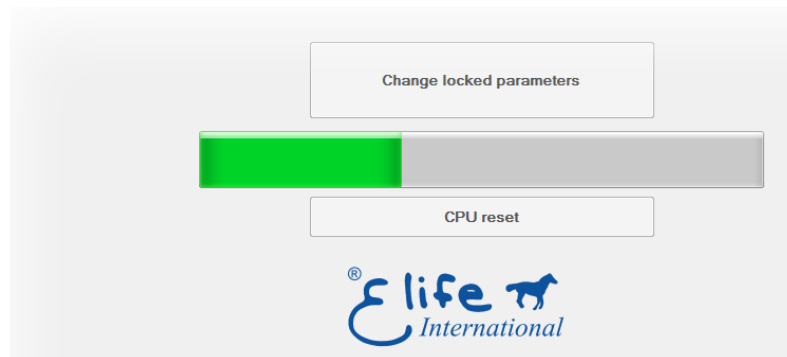

Figure 3.2: When the progress bar is running, Telemetry Panel downloads data from *.cfg* file to Elife-Drive.

3.4 Change Programmable Parameters

Programmable Parameters enables you to customize vehicle's performance characteristics to best fit your needs.

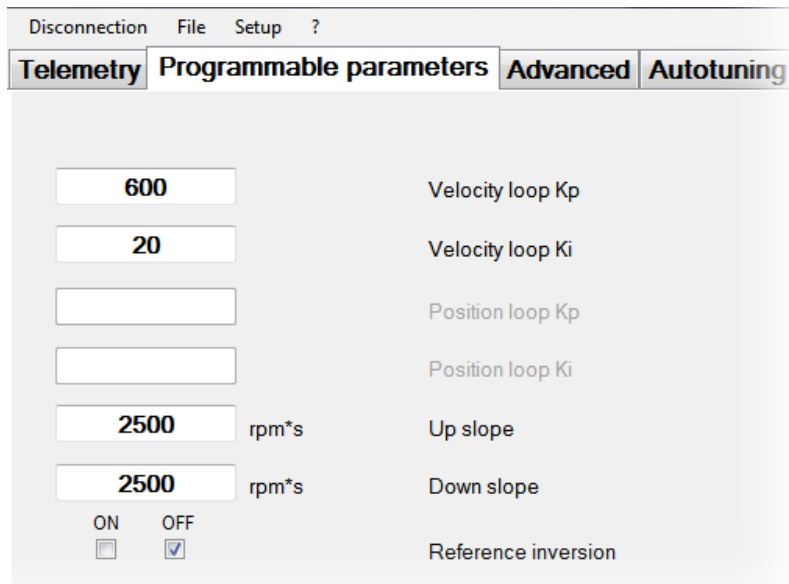

Figure 3.3: Programmable Parameters tab allows you to read and change the main programmable parameters and set the operating mode.

Note

Telemetry Panel automatically recognizes your Elife-Drive type and the feedback input (Resolver, Hall Sensor, SinCos Encoder, etc) that you've installed on your system. The **Parameters** that have their textboxes **empty and disabled** are not interesting for your model connected, for the operating mode selected or for your firmware version.

In *Programmable Parameters tab* (Figure 3.3) you can read and change the main programmable parameters and set the operating mode of Elife-Drive (*Standalone, PLC, etc*). After connecting your Elife-Drive to PC and **stopping the motor**, the values can be changed in Programmable Parameters tab.

Warning

We recommend saving preset programmable parameters to *.cfg* file before changing them, so that you can restore the preset parameters if necessary. See Section 3.3

3.4.1 Operating Mode and Controller Parameters

Velocity Loop Kp Proportional gain for closed-loop speed control, it must be less than 4096. This parameter is also programmable by CANopen[®] protocol.

Velocity Loop Ki Integral gain for closed-loop speed control, it must be less than 1024. This parameter is also programmable by CANopen[®] protocol.

Position loop Kp Proportional gain for closed-loop position control, it must be less than 16384. This parameter is also programmable by CANopen[®] protocol.

Position loop Ki Integral gain for closed-loop position control, it must be less than 128. This parameter is also programmable by CANopen[®] protocol.



Note

The gain parameters for closed-loop position control will only be processed if configuration is CANopen[®] and mode of operation is Profile Position Mode.

Speed closed loop This text box is only valid for DC motor.

Feedback inversion This text box is only valid for Brushless Motor with a **SinCos Encoder** as feedback system. If this checkbox is **ON** the SIN and COS signal from Encoder (see Table 2.13) are inverted by Software.

Encoder inversion This text box is only valid for DC motor.

NH Alarm Output If checked OFF, alarm output is normally low (NL), else it is normally high (NH).

Configuration This option sets the operating mode of Elife-Drive. The allowed values for this parameter are *Standalone, CAN Network, PLC* and *RS232* (in Speed or Torque Mode).



Warning

Elife-Drive must be wired up correctly according to the operating mode selected. See Chapter 2.

Max drive temperature At this drive temperature drive must rise "Drive over-temperature" alarm.

UNIT	MIN VALUE	MAX VALUE
°C	80	110
(°F)	(176)	(230)

Following error delay When the detected speed is less than 80 % or more than 120 % of the target speed over the set time, Elife-Drive stops the motor with *following error* alarm. This parameter is also programmable by CANopen[®] protocol.

UNIT	MIN VALUE	MAX VALUE
<i>s</i>	0	15

3.4.2 Motor and Acceleration Parameters

Up slope Lower values indicate a longer acceleration time and a more gradual departure, while bigger values indicate a faster acceleration. The implemented ramp is linear. This parameter is also programmable by CANopen[®] protocol.

UNIT	MIN VALUE	MAX VALUE	STEP
<i>rpm/s</i>	500	$35 \cdot 10^5$	500

Down slope Lower values indicate a longer deceleration time and a more gradual arrest, while bigger values indicate a faster deceleration. The implemented ramp is linear. This parameter is also programmable by CANopen[®] protocol.

UNIT	MIN VALUE	MAX VALUE	STEP
<i>rpm/s</i>	500	$35 \cdot 10^5$	500

Reference inversion Use to reverse the direction of rotation defined as positive.

Max motor speed It indicates the maximum allowed speed for the motor in either direction. It is used to protect the motor and must be taken from the motor datasheet. This parameter is also programmable by CANopen[®] protocol.

UNIT	MIN VALUE	MAX VALUE
<i>rpm</i>	0	7000

Max speed at slow mode It indicates the maximum allowed speed for the motor in either direction when *Slow* mode is selected.

UNIT	MIN VALUE	MAX VALUE
<i>rpm</i>	0	7000

Backward maximum speed Only valid for Elife-Drive M Series.

3.4.3 Throttle Parameters

Analogic input This parameter describes the analog operational mode used to process the speed potentiometer. It is processed only for PLC and Standalone.

VALUE	DESCRIPTION
0-10	Direction inversion is realized through direction digital input (DIR/FORWARD).
0-5-10	When the potentiometer value is between 5 and 10 V speed reference is positive. When it is less than 5 V speed reference is negative.
0-5	Direction inversion is realized through direction digital input (DIR/FORWARD)
0-2.5-5	When the potentiometer value is between 2.5 and 5 V speed reference is positive. When it is less than 2.5 V speed reference is negative

Deadband It is the percentage of deadband for potentiometer. Increasing deadband enlarges the stop range.

UNIT	MIN VALUE	MAX VALUE
%	0	50

Tips and Advice

This parameter is particularly useful for potentiometers that can't regularly go back to a clear idle point. Deadband must be wide enough to guarantee the transfer of driver to idle when accelerator mechanism is released.

3.4.4 CANopen[®] Parameters

Size Indicator if checked ON, the size of the data to be transmitted is specified in the last four bytes of the communication.

CANopen[®] address It's the CANopen[®] node-ID for the device that is the network-wide unique identifier for each device. When this parameter value is changed, device will be automatically reset.

UNIT	MIN VALUE	MAX VALUE
<i>integer</i>	0	127

CANopen® baudrate The baudrate for the CANopen® communication between PLC and the device. When this parameter value is changed, device will be automatically reset.

UNIT	ALLOWED VALUES
<i>Kbps</i>	1000 - 500 - 250



Note

The CANopen® values will only processed if Elife-Drive works in *CAN Network* or *PLC* configuration.

3.4.5 Locked Parameters

In Programmable Parameters tab there are a few programmable parameters which their text-boxes are disabled but filled with a value (Figure 3.4). You can unlock them and change their value.



Warning

These parameters are critical for the correct function of Elife-Drive. You should change these parameters carefully and only if necessary.

In order to change these parameters:

1. Click on **Change Locked Parameters** button.
2. Insert the password: **8192**

After unlocking, you will be able to change:

Current Loop Kp Proportional gain for closed-loop current control; it must be less than 1024. This parameter is also programmable by CANopen® protocol.

Current loop Ki Integral gain for closed-loop current control; it must be less than 512. This parameter is also programmable by CANopen® protocol.

<input type="text"/>	Current loop Kp
<input type="text"/>	Current loop Ki
<input type="text"/>	Motor poles
<input type="text"/>	Phase Advance
<input type="text"/> Arms	Maximum phase current
<input type="text"/> %A	Brake current reduction
<input type="text"/> degrees	Resolver/SinCos offset
<input type="text"/> degrees	Phase zero
<input type="text"/> degrees	Phase offset (backward)
<input type="text"/> degrees	Hall sensor phasing
<input type="text"/> Arms	S2 Maximum current
<input type="text"/> s	S2 time
<input type="text"/> us	Back-EMF sample duration
<input type="text"/> ms	Back-EMF sample period
<input type="text"/> V/1000 rpm	Ke

Change locked parameters

Figure 3.4: In Parameters Programmable tab there are some parameters locked. You can unlock them after clicking on *Change Locked Parameters* button.

 **Tips and Advice**

The Kp and Ki values can be calculated by using Telemetry Panel. See Section 3.5.1

Motor poles It indicates the number of motor poles and must be taken from motor datasheet.

UNIT	ALLOWED VALUES
<i>even integer</i>	4 - 6 - 8 - 10 - 44

Phase Advance Phase advance techniques provide field-weakening operation to improve efficiency and torque performance for brushless machines. This parameter indicates the phase advance angle with respect to back-EMF of phase current.

UNIT	MIN VALUE	MAX VALUE	STEP
<i>a.u.</i>	0	32	1

 **Tips and Advice**

Motors whose inductance value is high might require a high value of phase advance angle.

Maximum phase current It shows the maximum permissible current in the motor. This parameter is also programmable by CANopen[®] protocol.

UNIT	MIN VALUE	MAX VALUE
<i>Amperes RMS</i>	0	Max ²

Brake current reduction It is the reduction of current and voltage applied to motor. It's useful to reduce thermal dissipation due to service brake activation. It intervenes only after one minute from brake activation. Its value must be less than 50%.

Resolver/SinCos offset This parameter is only valid for Motor with Resolver or SinCos Encoder. Offset to sum to resolver/encoder position.

UNIT	MIN VALUE	MAX VALUE
<i>degree</i>	0	359.99

 **Tips and Advice**

Resolver/SinCos offset value can be calculated by using Telemetry Panel. See Section 3.5.3

Phase zero This parameter is only valid for Hall sensor drive. It must be chosen applying forward direction.

UNIT	MIN VALUE	MAX VALUE
<i>degree</i>	0	359.99

Phase offset(backward) This parameter is only valid for Hall sensor drive. It must be chosen after precisely setting of phase zero, applying backward direction.

UNIT	MIN VALUE	MAX VALUE
<i>degree</i>	0	359.99

² The maximum peak output current depends on the Elife-Drive model installed.



Tips and Advice

For phase zero and phase offset value we suggest to start with a small value (e.g. 0.05) and increase by 5 until motor consumption and sinewave are at their best.

Hall sensor phasing This parameter is only valid for Hall sensor drive. It indicates the relative position of Hall sensors.

UNIT	ALLOWED VALUES
<i>degree</i>	60 - 120

S2 Maximum current This text box is only valid for DC motor.

S2 time This text box is only valid for DC motor.

Back-EMF sample duration This text box is only valid for DC motor.

Back-EMF sample period This text box is only valid for DC motor.

Ke This text box is only valid for DC motor.

3.4.6 Advanced Parameters

Advanced tab allows you to read and change some more programmable parameters (Figure 3.5).

Some information about Elife-Drive - such as **firmware version**, serial number, customer code, *etc* - and **CANopen® parameters are displayed** in this tab.

➤ It's possible to **read** the following *telemetry data*:

Direct current It shows the actual value of direct current, that is one output for Park transform (stator current component proportional to the flux). Motor is working fine if it is about 0. It is given in arbitrary unit.

Quadrature current It shows the actual value of quadrature current, that is one output for Park transform (stator current component proportional to the rotor torque). It is given in arbitrary unit.

Direct voltage It shows the actual value of direct voltage, that is one output for PI closed-loop. It is given in arbitrary unit.

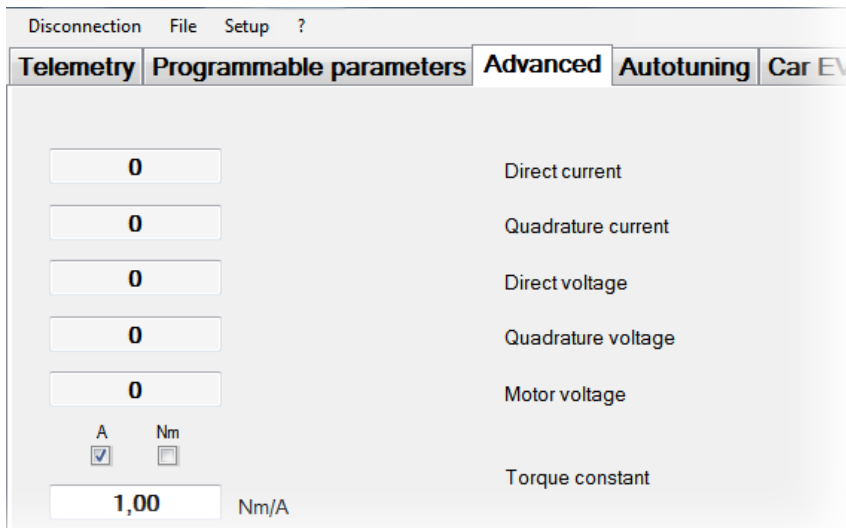

Figure 3.5: In Advanced tab is possible to read and change some more programmable parameters.

Quadrature voltage It shows the actual value of quadrature voltage, that is one output for PI closed-loop. It is given in arbitrary unit.

Motor voltage It shows the actual value of motor voltage. It is given in arbitrary unit.

➤ In Advanced tab you can also **modify** the following programmable parameters:

Torque constant This variable permits to convert motor torque current from *Amperes* to $N \cdot m$. This parameter is also programmable by CANopen[®] protocol.

UNIT	MIN VALUE	MAX VALUE
$N \cdot m/A$	0.00	10.00

Analog output This parameter is only available for Elife-Drive M Series.

Analog output function This parameter is only available for Elife-Drive M Series.

Brake fault alarm When turned OFF, Elife-Drive won't stop the motor nor inform about a brake failure.

Supply fault alarm When turned OFF, Elife-Drive won't stop the motor nor inform about a power supply relay failure.

Lower battery dynamic decrease if it turned ON, when the battery is being consumed Elife-Drive decrease automatically the speed in order to extend the battery life.

Overtravel warning When turned ON, Elife-Drive will stop the motor when one of two over-travel inputs will get high. Only for PLC Mode

Emergency input fault When this option is set OFF, the Elife-Drive stops motor rotation with emergency slope (disabling power relay and three-phase bridge) and unlocks motor brake but the controller doesn't trigger an alarm.

Power control If this option is set ON, Elife-Drive limits the max value of mechanical power of your motor for the nominal power of your Elife-Drive.

Feedback Alarm in Stop If this option is set OFF, the Feedback alarm is processed as warning when the Elife-Drive is in stop mode.

Emergency Slope This parameter configures alarm deceleration, lower values indicate a longer deceleration time and a more gradual arrest, while bigger values indicate a faster deceleration. The implemented ramp is linear. This parameter is also programmable by CANopen[®] protocol.

UNIT	MIN VALUE	MAX VALUE	STEP
<i>rpm/s</i>	500	$35 \cdot 10^5$	500

Temperature probe type From this combobox, user can select the correct PTC type from Thermostat, KTY83/122, KTY84/130 or none.



Note

If KTY83/122 or KTY84/130 is chosen, it will also be possible to read motor temperature from *Telemetry tab*.

Maximum motor temperature At this temperature drive must rise *Motor overtemperature* alarm.

UNIT	MIN VALUE	MAX VALUE
$^{\circ}C$	0	255
$(^{\circ}F)$	(32)	(491)

Encoder resolution This parameter is only available for DC motors.

Mechanical reducer This parameter is only available for DC motors.

Emulated encoder resolution This parameter is only available for Elife-Drive M Series.

Potentiometer Supply This parameter is only available for Elife-Drive M Series.

TPD02 transmission type It sets the type of transmission for TPDO2. It's only processed if configuration is CANopen[®] and can be programmable by CANopen[®] protocol also.

UNIT	MIN VALUE	MAX VALUE
<i>integer</i>	1	255

RPD02 transmission type It sets the type of transmission for RPDO2. It's only processed if configuration is CANopen[®] and can be programmable by CANopen[®] protocol also.

UNIT	MIN VALUE	MAX VALUE
<i>integer</i>	1	255

In Advanced tab there is also **Reset Alarm** button which allows you to reset all current alarms.

3.5 Auto-tuning Elife-Drive Parameters

Telemetry Panel includes two functions which help you to estimate approximate value of the following parameters:

- The gain parameters for closed-loop current control.
- The Offset Resolver/SinCos to sum to resolver/encoder position.



Warning

Please note that the suggested parameters are only a point of departure. They must be adjusted according to system and you should run the motor only after checking them.

3.5.1 Gain Parameters for closed-loop Current Control

In order to calculate the value of K_p and K_i for closed-loop current control you need two basic motor information: **Winding resistance** and **Winding inductance**.

To calculate Kp and Ki values by Telemetry Panel:

1. Move to Tuning tab (Figure 3.6).
2. Insert the **Winding resistance** and **Winding Inductance**² and the **Nominal Voltage** of your battery system.



Note

If CANopen[®] Mode is used, you can also insert the CANopen[®] SYNC period for a correct value of auto-tuning parameters.

3. Click on *Calculate* button.

The Telemetry Panel shows you the value of Kp and Ki and gets you some additional information (Cut Frequency, Motor RL Constant, PWM attenuation) which can be useful to tune Kp and Ki parameters. Elife-Drive also suggests you the max value of Slope³ for acceleration and deceleration ramps (See Section 3.4.2).



Note

If the *Send Calculate data to Elife-Drive* is checked **ON**, Telemetry Panel will automatically send the suggested current loop Kp and Ki values and slope for acceleration and deceleration ramps to Elife-Drive.

3.5.2 Finding the Min and Max values for SinCos Encoder

If your motor has installed a **SinCos Encoder** as feedback system, you **must** find the min and max values of sine and cosine functions to detect the proper angle position.



Warning

Before starting the SinCos adjustment function, the motor shaft must be free from load and free to rotate. All testing and adjustment must be done in safe condition.

²You should normally find these parameters on *data-sheet* of your *motor*, otherwise you must ask the motor manufacturer to provide these data.

³In CANopen[®] mode the value is automatically convert from *rpm/s* to *canopen acceleration unit*

Current loop gain and slopes calculation

Winding resistance Ohm

Winding inductance H

Nominal voltage V

CANopen SYNC period ms

Send calculated data ON OFF

Calculate

Cut frequency Hz

Motor RL constant s

PWM attenuation

K

Suggested current loop Kp

Suggested current loop Ki

Maximum suggested slope rpm/s

Figure 3.6: In Autotuning tab allows you to estimate gain parameters for closed-loop current control.

In order to find these values, you can use the SinCos adjustment function (Figure 3.7b).

1. Move to *Programmable Parameters* tab.
2. Choose **RS232 Speed** as *Configuration*.
3. Move to *Autotuning* tab and check if **Feedback state** is green, else see Appendix A.
4. Click on **Start** button and wait for about 30 seconds (Figure 3.7b).



Tips and Advice

If in this operation your motor goes out of control, you should make sure that the feedback connections have been correctly realized (See Table 2.13). You can also invert the SIN and COS signal by Software (See *Feedback inversion* Option, Pag. 37).



Note

If the motor **doesn't rotate correctly**, you should increase the **VMA value** by 5 and click Start button again until the motor will make one revolution.

After clicking the Start button the Telemetry Panel shows you the min and maximum of the sine and cosine signals from your SinCos Encoder installed (these values depend both the type of SinCos Encoder chosen and from how it's mounted on the motor). Telemetry Panel **automatically send** to Elife-Drive the values founded.

3.5.3 Offset Resolver/SinCos

Finding the correct value of *Offset Resolver/SinCos* is critical to the proper functioning of the system. Telemetry Panel helps you determine the correct value of *Offset Resolver/SinCos* to sum to resolver/SinCos position:



Warning

Before starting the auto-tuning procedure, you had better lift your vehicle up. The driving wheels must be off the ground and free to rotate. All testing and adjustment must be done in safe condition.

1. Move to *Programmable Parameters* tab.
2. Choose **RS232 Speed** as *Configuration*.
3. Move to *Tuning* tab and check if **Feedback state** is green, else see Appendix A.
4. **For SinCos Encoder:** Before finding the offset value, you must run the SinCos adjustment function (See Section 3.5.2)
5. Set the *Test Current* in *Amperes RMS* (Figure 3.7a). This value depends on motor dimension and characteristics.
6. Click on *Find Offset* button and wait for the progress bar to get completely green.
7. Manually rotate the motor shaft by half a turn and then click on *Find Offset* button **again**. If the value obtained is not the same of the previous value (± 0.1 degree) you must increase the **Test Current** and repeat the procedure.
8. Check that motor runs through *Velocity Target* trackbar.



Note

Telemetry Panel will automatically send the new value of *Offset Resolver/SinCos* calculated to Elife-Drive.

In *Resolver Autotuning* panel you can see two LED indicators:

Feedback state This alarm indicates that resolver cable isn't connected or that resolver is broken. If led is red, it won't be possible to accomplish resolver autotuning.

Brake state This led reflects the brake setting: when brake is locked led is green, when unlocked led is yellow. When led is red, it indicates a brake failure.

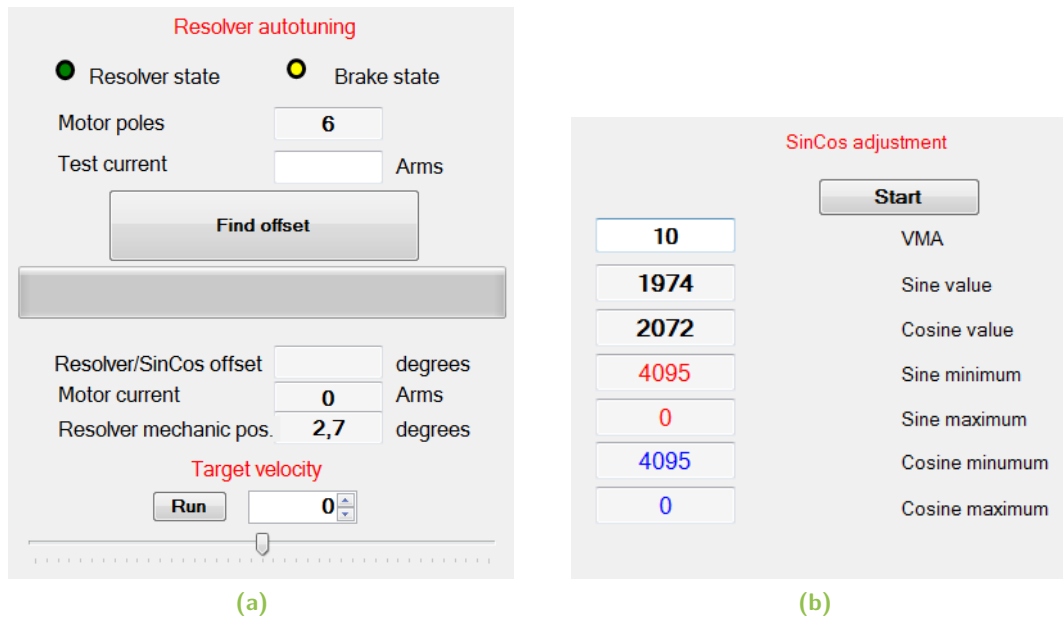

Figure 3.7: Telemetry Panel helps you to find the correct value of (a) offset Resolver/SinCos value . In case you've mounted a SinCos Encoder on your motor, you must before running (b) the SinCos adjustment function.

Warning
 The auto-tuning offset procedures are only valid if your motor is connected in star. **For SinCos Encoder:** The SinCos adjustment function - to find the min and max values of sine and cosine functions - is valid both star and triangle (or Delta) connection

Note
 The Elife-Drives (XXXXX-7 Series) allow you to set the **Excitation amplitude, Input sensitivity** and **Excitation frequency** parameters. This values must be chosen in according to the Resolver Technical Datasheet.

Monitoring Elife-Drive

After wiring up correctly Elife-Drive (See Chapter 2) and adjusting the programmable parameters (See Chapter 3), you are finally ready to test your system.



Warning

Before starting the test, you had better lift your vehicle up. The driving wheels must be off the ground and free to rotate. All testing and adjustment must be done in safe condition.

4.1 LED Diagnostics

Elife-Drive has an LED light on the front of the device that visually explains what the driver is doing. Below is the explanation of the different LED's status:

Blinking ORANGE Elife-Drive works correctly, motor is stopped

Blinking GREEN Elife-Drive works correctly, motor is running

Steady RED Elife-Drive detects one or more alarms. In this case, Elife-Drive stops motor rotation (disabling power relay and three-phase bridge) and unlocks motor brake.

If **CANopen[®]** mode is set, and the **CANopen[®]** FSA State is *Switch on disabled*, led will be **steady ORANGE** until it will receive shutdown command from PLC, independently from alarms or motor state.

4.2 Reading Telemetry Data from Telemetry Panel

Elife-Drive collects several types of telemetry data which allows you to understand better how your driver works.

Telemetry Panel¹ shows telemetry data values for each operating mode selected (Standalone,PLC,CAN Network,RS232).

Tips and Advice

In order to test your device for the first time, we suggest to select **RS232** (in Speed or Torque mode) as *Configuration* in *Programmable Parameters* tab. So you will be able to manually set the target velocity of your motor (See Section 2.3.4 and Section 4.2.4).

In Telemetry Panel you can read the following telemetry-data:

Motor velocity It is the detected speed, expressed in rotations per minute (*rpm*).

Velocity setpoint It displays the actual velocity target. This value is gotten from:

- The **Potentiometer** for *PLC* and *Standalone* configuration.
- The **CAN master** if you set *CAN Network* or *PLC* in *CANopen*[®] configuration as *Configuration*.
- The **Target Velocity Trackbar** for *RS232* configuration.

Mechanic. pos. It shows the resolver/encoder mechanical position in mechanical degrees. This is displayed only for Brushless motor with Resolver/SinCos.

Motor current or Torque This shows the actual motor current (*Ampere RMS*) or the Torque (*N·m*) value.

Note

You can choose to read either the *motor current* or the *torque* in *Advanced* tab. See Section 3.4.6.

Heat sink temperature Temperature of Elife-Drive heat-sink.

Drive Temperature Temperature of Elife-Drive.

Motor Temperature This information is available only if *Temperature probe type* parameter in *Advanced tab* is **KTY83/122** or **KTY84/130**.

¹In Chapter 3 is explained the details how install and connect your Elife-Drive to PC.



Figure 4.1: Telemetry Panel displays a wide range of telemetry data and enables you to plot or log these data over time.



Note

Under *Setup* → *Temperature Scale* menu you can choose to display temperature values in Celsius or Fahrenheit degrees.

Bus voltage It shows the real-time bus voltage.

Analog input 2 It's only displayed for Elife-Drive M Series.

Output Power It shows the mechanical power². You must make sure that the value of *Torque constant* (See Section 3.4.6) is correctly set.

Actual position It shows the actual of position control closed-loop. This parameter is processed only for *CAN Network* configuration when the operational mode is *Profile position mode*.

Position setpoint It is the position target of position control closed-loop. This parameter is processed only for *CAN Network* configuration when the operational mode is *Profile position mode*.

Motor state This text box indicates if motor is stopped or if it is running, and in which direction.

VALUE	DESCRIPTION
CCW rotation	Counterclockwise rotation, backward direction
CW rotation	Clockwise rotation, forward direction

4.2.1 Alarm Indicators

The Alarm Indicators on *Telemetry* tab enable you to determine what kind of errors are present. When Elife-Drive detects one or more alarms stops motor rotation (disabling power relay and three-phase bridge) and unlocks motor brake.

A **green led** means that the corresponding alarm isn't signaled, while a **red led** means that the alarm is active.

The Alarm indicators are as follows:

Configuration This error appears when:

- No *configuration* (Standalone, CAN Network, PLC, RS232) is selected.

²The mechanical power is derived as follows: $P = (Torque * 2\pi * rpm) / 60$

- Set *pole number* is different from allowed values.
- The internal memory of Elife-Drive has never been programmed.

Following This kind of alarm happens when the detected speed is less than 80% or more than 120% over the set time period (See Section 3.4.6).

Drive overtemperature This alarm happens when the drive temperature is higher than *max drive temperature degrees* (See Section 3.4.6).

Communication timeout This alarm happens when configuration is **Steering** and driver measure a communication timeout.

Feedback This alarm indicates that the feedback cable isn't properly connected or that the feedback is broken.



Tips and Advice

By a **Popup Window**, Elife-Drive shows you additional information about Feedback Alarm.

Overcurrent It happens whenever one of the modules of three current phases is higher than a threshold.

Emergency input It indicates that the emergency input is not supplied, if LED is yellow it means that drive just set target velocity to 0. It is processed only for *PLC*, *Standalone* and for *RS232 configuration*.

Overvoltage This error is showed when bus voltage is higher than 80 V for 24 ÷ 48 models and 122 V for 48 ÷ 96 models.

Setpoint error It indicates that speed potentiometer isn't initially put to 0. It's processed only for *Standalone* configuration.

Analogic interruption It indicates that analog input for velocity reference isn't connected. It's processed only for *PLC* and *Standalone* configuration.

Motor overtemperature This alarm appears when:

- Motor temperature exceeds *Maximum motor temperature* value if set PTC type is *KTY83/122* or *KTY84/130*.

- Motor temperature sensor isn't connected if *Thermostat* is selected as PTC type.

Safety It is only displayed for Elife-Drive M Series.

Stalled Rotor It's alarm appears when the motor is blocked and at the same time the phase current is high about for approximately for a second.

Other This alarm is showed when bus voltage is lower than 12 V.

For information on troubleshooting possible issues, see Appendix A.

4.2.2 Reset all Current Alarms

In *Advanced Tab* is present a **Reset Alarms** button that allows you to reset all running alarms.



Tips and Advice

It's also possible to reset all running alarms with a *rising edge* signal (transition from low to high) at the **PIN 15** (RUN / STOP) in **Standalone** and **PLC** configuration and with a *fault reset command* if you employ **CAN telemetry protocol**.

4.2.3 Digital I/O and Drive State Indicators

The I/O indicators enables you to read in real-time the status of input and output signal. If a led indicator is **green** means that the corresponding input/output is active: it's **supplied** if it's an **input** pin or it **sends** a signal if it's an **output** pin. The meaning of different input/output pins in according to the operating mode selected - *PLC, Standalone, CAN Network, RS322* - is given in Table 4.1.

Table 4.1: Description of Digital I/O indicators in Telemetry Panel.

	STANDALONE	PLC	CAN NETWORK	RS232
Input 1	HANDBRAKE	CCW OVERTRAVEL	Positive limit switch	/
Input 2	FAST / SLOW	CW OVERTRAVEL	Negative limit switch	/
Input 3	FORWARD ^a	Direction ^a	Home switch	/
Input 4	BACKWARD ^a	RUN CAN address 0	CAN address 0	/
Input 5	EMERGENCY	EMERGENCY CAN address 1	CAN address 1	EMERGENCY
Output 1	Reverse	/	/	/
Output 2	Drive status	/	/	/
Output 3	Drive alarm			
Output 4	Encoder emulator			

^a Only if "Analog input" is 0-10V or 0-5V.

The **Drive State Indicators** get you some information about the following Elife-Drive state:

Power Relay This led reflects the supply relay:

STATUS	MEANING
Green	The relay is enabled
Yellow	The relay is disabled
Red	Power supply relay failure



Tips and Advice

If you get this alarm only when you give RUN command, this behavior is probably due to a Resolver problem (See Appendix A and read the **Feedback Alarm** troubleshooting).

Brake State This led reflects the brake setting:

STATUS	MEANING
Green	The brake is locked
Yellow	The brake is unlocked
Red	The brake failure

Speed Limitation This indicator is yellow when quadrature current is saturating and so drive is limiting velocity.

Inversion fuse This indicator is red when **F+** and **B-** connections have been inverted at least once.

Period overcurrent It's displayed only for DC motors.

CW overtravel This indicator is yellow when drive is stopped because driver CW OVERTRAVEL input is high.

CCW overtravel This indicator is yellow when drive is stopped because driver CCW OVERTRAVEL input is high.

 **Note**

Some of these controls can be disabled in *Advanced tab*. See Section 3.4.6.

4.2.4 The Target Velocity/Torque Track Bar

The *Target velocity/Target torque* track bar is enabled on Telemetry Tab when **RS232** velocity/torque mode is chosen as *Configuration* in Programmable Parameters Tab (Figure 4.2).

This track bar allows you to manually set the target velocity - or torque - value of your Motor from 0 to the *Max value* that you have set as the *Max motor Speed* (See Section 3.4.2). The sign of value determine the direction of rotation:

VALUE	DIRECTION OF ROTATION
Positive	CW
Negative	CCW

This function can be useful for testing your motor, without worrying about other devices (e.g: potentiometer) or other controllers (e.g: PLC).

You can also put the exact value of desired target velocity/torque on the textbox at the left end of the track bar.

4.3 Plot and Log Telemetry Data in Real-Time

In telemetry Panel you can also plot telemetry data over time and create a log file to view later in a spreadsheet program.

Telemetry Panel allows you to set the following plot parameters:

Y-axis Scale *Y Max* and *Y Min* set the maximum and minimum value the y-axis of the plot.

Time Scaling You can choose how much time to display in X-axis in **X Scaling**:

VALUE	DESCRIPTION
x1	1s/div
x2	2s/div
x3	3s/div
...	

After adjusting the X/Y ranges you can plot and log telemetry data following below instructions.

1. Select one or more (max four) telemetry data that you'll want to observe from *TRACE 1*, *TRACE 2*, *TRACE 3* or *TRACE 4* list (Figure 4.3).
2. Click on *Play button*.
3. If you want to log these data click on *Save button* and enter a descriptive name in the file name box and click Save.
4. Click on *Stop button* when you want to stop collecting data.
5. To stop plotting telemetry data and freeze the plot you must click on *Pause button*.



Figure 4.2: Target Velocity track bar is enabled by the RS232 mode when this operating mode has been chosen as *Configuration* in Programmable Parameters tab.

Table 4.2: Plotting and logging telemetry data with Telemetry Panel.





BUTTON	FUNCTION	BUTTON	FUNCTION
	Play Button Start to plot telemetry data		Pause Button Stop plotting telemetry data
	Save Button Start to log telemetry data		Stop Button Stop collecting telemetry data



Figure 4.3: Telemetry Panel allows you to plot and log one or more telemetry data.

Maintenance

Elife-Drive no needs any maintenance interventions. It's only necessary to keep the contacts and the controller clean and dry. The fuse is the only user-serviceable part in the Elife-Drive (See Table 2.2, Pag. 7).



Warning

Never attempt to disassemble, repair, or modify the Elife-Drive yourself, penalty the voiding of the warranty rules.

If you perform a maintenance operation on your system owing to a problem, it could be useful to read the **error messages** that have been sent by UNDRIVE. You can read these messages in one of the following ways:

Diagnostic Display Elife Diagnostic Display allows you to get some information about battery - autonomy and voltage - and Elife-Drive fault codes.

Telemetry Panel Telemetry Panel enables you to control your Elife-Drive and read a wide range of telemetry data (See Chapter 4).

CAN Network The error messages that have been sent by Elife-Drive can be read through the CANopen[®] protocol¹.

RS232 You can read the error messages through the RS232 protocol².

For more information on the meaning of error messages and troubleshooting procedures, see Section 4.2.1 and Appendix A.

¹For further information, see **Elife-Drive - CANopen[®]** manual

²For further information, see **Elife-Drive - RS232 Communication Protocol** document

Troubleshooting: Alarm Messages

This section covers only the common and likely causes of alarm messages and actions that should be taken by the operator.

Elife-Drive alarms can be interpreted using the **Telemetry Panel** (See Chapter 5), **Elife Diagnostic Display** or can be read through the **CanOpen[®]** Protocol also.

Note

In Advanced Tab in Telemetry Panel software is present a **Reset Alarms** button that allows you to reset all running alarms.

After the resolution of the problem, Elife-Drive might need to be restarted.

Configuration Alarm

DESCRIPTION This error appears when:

- No *configuration* (Standalone, CAN Network, PLC, RS232) is selected.
- Set *pole number* is different from allowed values.
- The internal memory of Elife-Drive has never been programmed.

Elife-Drive BEHAVIOUR After switch on, drive won't enable power relay and three-phase bridge.

POSSIBLE TROUBLESHOOTING ISSUE

1. Check if a configuration is selected in the **Configuration** list (See Section 3.4.1).
2. If the other programmable parameters are null, it also needs to download parameters from motor configuration file (See Section 3.3).
3. Check if the **pole number** value is correct (See Section 3.4.5).

Following Alarm

DESCRIPTION This kind of alarm happens when the detected speed is less than 80% or more than 120% over the set time period (See Section 3.4.6).

Elife-Drive BEHAVIOUR Elife-Drive stops motor rotation with emergency slope (disabling power relay and three-phase bridge) and unlocks motor brake.

POSSIBLE TROUBLESHOOTING ISSUE There are two possible reasons for this alarm: the phase current isn't sufficient to accomplish operation or your motor is unable to attain the desired speed.

- Check the integrity of the fuse.
- Check if the motor is braked.
- Check the maximum phase current (See Section 3.4.5) is correct for your motor.
- Check if the gain parameters for closed-loop velocity control fit your needs.
- Increasing the *Following error delay* value (See Section 3.4.6).
- Decrease the *Max motor speed* if your motor is unable to achieve it (See Section 3.4.2).

Drive overtemperature Alarm

DESCRIPTION This alarm happens when the drive temperature is higher than the set *maximum drive temperature* degrees (See Section 3.4.6).

Elife-Drive BEHAVIOUR Elife-Drive stops motor rotation with emergency slope (disabling power relay and three-phase bridge) and unlocks motor brake.

POSSIBLE TROUBLESHOOTING ISSUE Restore drive temperature conditions, then reset alarms. If the error appears frequently, you must improve heat exchange between the Elife-Drive and the vehicle surface (See Section 2.1).

Communication timeout Alarm

DESCRIPTION This alarm happens when configuration is **Steering** and master measure a communication timeout.

Elife-Drive BEHAVIOUR Elife-Drive stops motor rotation with emergency slope (disabling power relay and three-phase bridge) and unlocks motor brake.

POSSIBLE TROUBLESHOOTING ISSUE Check configuration and wiring between the Elife-Drive and master (See **Elife-Drive - Steering Mode Manual**).

Feedback Alarm

DESCRIPTION The Feedback cable isn't properly connected or otherwise if this error appears when your motor is running, the possible causes are:

- Lack of earth interconnection between motor housing and driver negative terminal (-).
- Probable leakage between motor housing and phases.
- The Feedback cable passed near power cables.
- **For Resolver and SinCos:** Radial misalignment between Resolver/SinCos stator and rotor (this results in driver input signal undervoltage).
- **For Hall Sensor:** The Hall sensors are not precisely linked.

Elife-Drive BEHAVIOUR Elife-Drive stops motor rotation with emergency slope (disabling power relay and three-phase bridge) and unlocks motor brake.

POSSIBLE TROUBLESHOOTING ISSUE **Firstly**, check the feedback cable connection:

1. Check the feedback cable connection on driver/feedback side.
2. Check the electrical integrity of the cable, pay specific attention to the cable's shield.

3. Ensure that the feedback cable was constructed specifically for the feedback type mounted on your motor. It's essential that the feedback cable is of the high quality.
- If these checks failed, you must:
1. Check the correct connection between motor housing appropriate terminal and driver negative terminal (-).
 2. Check electrical isolation between every phase and motor housing.
 3. Pass feedback cable as far as possible from power cables.
 4. Check the correct Resolver/SinCos installation within motor.

Overcurrent Alarm

DESCRIPTION It happens whenever one of the modules of three current phases is higher than a threshold.

Elife-Drive BEHAVIOUR Elife-Drive stops motor rotation with emergency slope (disabling power relay and three-phase bridge) and unlocks motor brake.

POSSIBLE TROUBLESHOOTING ISSUE The possible actions that should be taken:

- Check the proper functioning of the feedback system.
- Check if the gain parameters for closed-loop current control are not too high for your application (See Section 3.4.5).

If this error appears when your motor is in **generator mode**, the voltage generated by your motor is higher than the battery voltage: Change your battery system or decrease the Max motor speed value (See Section 3.4.2).

Emergency input Alarm

DESCRIPTION It indicates that the emergency input is not supplied. It's processed only for *PLC*, *Standalone* and for *RS232 configuration*.

Elife-Drive BEHAVIOUR Elife-Drive stops motor rotation with emergency slope (disabling power relay and three-phase bridge) and unlocks motor brake.

POSSIBLE TROUBLESHOOTING ISSUE Check the *Emergency Input (PIN 3)*, then reset alarms.

Overvoltage Alarm

DESCRIPTION This error is showed when bus voltage is higher than 80 V for 24 ÷ 48 models and 122 V for 48 ÷ 96 models.

Elife-Drive BEHAVIOUR Elife-Drive stops motor rotation with emergency slope (disabling power relay and three-phase bridge) and unlocks motor brake.

POSSIBLE TROUBLESHOOTING ISSUE There are two possible explanation for this alarm:

- Battery voltage, or battery charging voltage, is too high for the Elife-Drive Type installed.
- The voltage generated by your motor, when is in **generator mode**, is higher than the battery voltage: Change your battery system or decrease the Max motor speed value (See Section 3.4.2).

Setpoint Alarm

DESCRIPTION It indicates that the speed potentiometer isn't initially put to 0 or the speed potentiometer is grater than 25% of the end-of-stroke during the start phase of the motor. It's processed only for *Standalone* configuration.

Elife-Drive BEHAVIOUR After switch on, drive won't let motor run.

POSSIBLE TROUBLESHOOTING ISSUE Put the speed potentiometer to idle state, then reset alarms.

Analogic interruption Alarm

DESCRIPTION It indicates that analog input for velocity reference isn't connected. It is processed only for PLC and Standalone configurations.

Elife-Drive BEHAVIOUR When motor is rotating, if analog input cable will disconnect or break during run operation, Elife-Drive stops motor rotation with emergency slope (disabling power relay and three-phase bridge) and unlocks motor brake.

POSSIBLE TROUBLESHOOTING ISSUE Check the *wiring* between **PIN 21** (AIN / WIPER POT) and Elife-Drive.

Motor overtemperature Alarm

DESCRIPTION This alarm appears when:

- Motor temperature exceeds *Maximum motor temperature* value if set *Temperature probe type* is *KTY83/122* or *KTY84/130*.
- Motor temperature sensor isn't connected if *Thermostat* is selected as *Temperature probe type*.

Elife-Drive BEHAVIOUR Elife-Drive stops motor rotation with emergency slope (disabling power relay and three-phase bridge) and unlocks motor brake.

POSSIBLE TROUBLESHOOTING ISSUE If motor hasn't any PTC, set **none** as *Temperature probe type* option (See Section 3.4.6. Otherwise, restore motor temperature conditions, then reset alarms.

Stalled rotor Alarm

DESCRIPTION This alarm appears when the motor is blocked and at the same time the phase current is high about for approximately for a second. For instance, the vehicle's wheels are blocked by an obstacle.

Elife-Drive BEHAVIOUR Drive won't enable power relay and three-phase bridge.

POSSIBLE TROUBLESHOOTING ISSUE Find the cause of the block and then remove it.

Other

DESCRIPTION This alarm is showed when bus voltage is lower than 12 V.

Elife-Drive BEHAVIOUR After switch on, drive won't enable power relay and three-phase bridge.

POSSIBLE TROUBLESHOOTING ISSUE The possible actions that should be taken:

- Check the integrity of the fuse.
- If this error appears always when you run Elife-Drive, contact the technical assistance.

Index of Programmable Parameters

Table B.1: Index of Elife-Drive Programmable Parameters in alphabetical order.

NAME	OPERATING RANGE			PROGRAMMABLE by CANOPEN®	REFERENCE
	UNIT	MIN	MAX		
Analogic input	<i>allowed values</i>				Pag. 39
Brake current reduction	%	0	50		Pag. 42
Brake fault alarm	<i>boolean value</i>				Pag. 44
CANopen® address	<i>integer</i>	0	127		Pag. 39
CANopen® baudrate	<i>allowed values</i>				Pag. 40
Configuration	<i>allowed values</i>				Pag. 37
Current Loop Ki	<i>a.u.</i>	0	512	●	Pag. 40
Current Loop Kp	<i>a.u.</i>	0	1024	●	Pag. 40
Deadband	%	0	50		Pag. 39
Down slope	<i>rpm/s</i>	500	$35 \cdot 10^5$	●	Pag. 38
Emergency input fault	<i>boolean value</i>				Pag. 45
Emergency Slope	<i>rpm/s</i>	500	$35 \cdot 10^5$	●	Pag. 45
Feedback inversion	<i>boolean value</i>				Pag. 37
Following error delay	<i>s</i>	0	15	●	Pag. 38
Hall sensor phasing	<i>degree</i>	60	120		Pag. 43
Lower battery dinamic decrease	<i>boolean value</i>				Pag. 44
Max drive temperature	°C (°F)	80 (176)	110 (230)		Pag. 37
Max motor speed	<i>rpm</i>	0	7000	●	Pag. 38
Max speed at slow mode	<i>rpm</i>	0	7000		Pag. 38
Maximum motor temperature	°C (°F)	0 (32)	255 (491)		Pag. 45

Continued on next page ...

... continued from previous page

NAME	OPERATING RANGE			PROGRAMMABLE by CANOPEN®	REFERENCE
	UNIT	MIN	MAX		
Maximum phase current	<i>Amperes RMS</i>	0	Max	●	Pag. 42
Motor poles	<i>integer</i>	4	44		Pag. 41
NH Alarm Output	<i>boolean value</i>				Pag. 37
Overtravel warning	<i>boolean value</i>				Pag. 45
Phase Advance	<i>a.u.</i>	0	32		Pag. 41
Phase offset(backward)	<i>degree</i>	0	359.99		Pag. 42
Phase zero	<i>degree</i>	0	359.99		Pag. 42
Position Loop Ki	<i>a.u.</i>	0	128	●	Pag. 37
Position Loop Kp	<i>a.u.</i>	0	16384	●	Pag. 36
Power Control	<i>boolean value</i>				Pag. 45
Reference inversion	<i>boolean value</i>				Pag. 39
Resolver/SinCos offset	<i>degree</i>	0	359.99	●	Pag. 42
RPD02 transmission type	<i>integer</i>	1	255	●	Pag. 46
Size Indicator	<i>boolean value</i>				Pag. 39
Supply fault alarm	<i>boolean value</i>				Pag. 44
Temperature probe type	<i>allowed values</i>				Pag. 45
Torque constant	<i>N·m/A</i>	0	10	●	Pag. 44
TPD02 transmission type	<i>integer</i>	1	255	●	Pag. 46
Up slope	<i>rpm/s</i>	500	$35 \cdot 10^5$	●	Pag. 38
Velocity Loop Ki	<i>a.u.</i>	0	1024	●	Pag. 37
Velocity Loop Kp	<i>a.u.</i>	0	4096	●	Pag. 36

Concluded

© Elife International 2018

www.elifelifeinternational.com