

# User Manual

# RM72A

## 2-Phase Digital Stepper Drive

RAVED

www.raveo.cz

CE RoHS

### RM72A

#### Microstep Drive

RS232 5V 24V

PWR/ALM

Current Table (Peak= RMSX1.4)

Peak	RMS	SW1	SW2	SW3
2.40A	1.71A	on	on	on
3.08A	2.20A	off	on	on
3.77A	2.70A	on	off	on
4.45A	3.18A	off	off	on
5.14A	3.67A	on	on	off
5.83A	4.16A	off	on	off
6.52A	4.66A	on	off	off
7.20A	5.14A	off	off	off

SW4: off= Half Current; on= Full Current

Pulse/rev Table

Pul/r	SW5	SW6	SW7	SW8
400	on	on	on	on
800	off	on	on	on
1600	on	off	on	on
3200	off	off	on	on
6400	on	on	off	on
12800	off	on	off	on
25600	on	off	off	on
51200	off	off	off	on
1000	on	on	on	off
2000	off	on	on	off
4000	on	off	on	off
5000	off	off	on	off
8000	on	on	off	off
10000	off	on	off	off
20000	on	off	off	off
40000	off	off	off	off

SW9: Pulse Mode, on=CW/CCW, off=Step/Dir  
 SW10: Filter Time, on=12ms, off=Disable

**30 - 90 VDC**

**Hardware Version 2.0**  
**Manual Revision 1.0**

## Table of Contents

<b>1. Introductions</b> .....	<b>1</b>
1.1 Features .....	1
1.2 Applications .....	1
<b>2. Specifications</b> .....	<b>1</b>
2.1 Electrical Specifications.....	1
2.2 Environment .....	2
2.3 Mechanical Specifications.....	2
2.4 Elimination of Heat .....	2
<b>3. Connection Pin Assignments and LED Indication</b> .....	<b>3</b>
3.1 P1 - Control Connector .....	3
3.2 P2 - Fault and Brake Output Connector .....	3
3.3 P3 - Motor and Power Supply Connector .....	4
3.4 P4 - Tuning Connector.....	4
3.5 LED Light Indication .....	4
<b>4. Control Signal and Output Signal</b> .....	<b>5</b>
4.1 Control Signal Connection.....	5
4.2 Fault and Brake Output Connection.....	5
<b>5. Motor Connection</b> .....	<b>6</b>
5.1 Connections of 4-lead Motor .....	6
5.2 Connections of 6-lead Motor .....	6
5.2.1 Half Coil Configuration .....	6
5.2.2 Full Coil Configuration .....	7
5.3 Connections of 8-lead Motor .....	7
5.3.1 Series Connection.....	7
5.3.2 Parallel Connection.....	7
<b>6. Power Supply Selection</b> .....	<b>8</b>
6.1 Regulated or Unregulated Power Supply .....	8
6.2 Power Supply Sharing .....	8
6.3 Selecting Supply Voltage .....	8
<b>7. DIP Switch Configurations</b> .....	<b>9</b>
7.1 Microstep Resolution Configurations.....	9
7.2 Output Current Configurations .....	9
7.2.1 Dynamic Current Configurations .....	10
7.2.2 Idle Current Configuration .....	10
7.3 Control Mode Configurations .....	10
7.4 Smoothing Time Configuration .....	10
7.3 Automatic Motor Matching & Self Configuration .....	10
<b>8. Wiring Notes</b> .....	<b>10</b>
<b>9. Typical Connection</b> .....	<b>11</b>
<b>10. Sequence Chart of Control Signals</b> .....	<b>11</b>
<b>11. Protection Functions</b> .....	<b>12</b>
<b>12. Troubleshooting</b> .....	<b>13</b>
<b>13. Warranty</b> .....	<b>14</b>
<b>14. Contact Us</b> .....	Chyba! Záložka není definována.

## 1. Introductions

The RM72A is a digital stepper drive with simple design and easy setup. By implementing advanced stepper control technology, this stepper drive is able to power 2-phase and 4 phase stepper motors smoothly with optimal torque and low motor heating & noise. Its operating voltage is 18-80VAC or 24-110VDC and it can output up to 7.2A current. All the micro step and output current configurations can be easily done via built in DIP switches. Its control type (step & direction or CW/CCW) and command smooth filtering can also be configured via DIP switches. Therefore, the RM72A are ideal choices for applications requiring simple step & direction control of NEMA 23, 24, 34, and 42 stepper motors.

### 1.1 Features

- Step & direction (PUL/DIR) or CW/CCW (double pulse) control
- Input voltage 18-80VAC or 24-110VDC (recommended 20-70VAC or 30-90VDC)
- 200 KHz max pulse input frequency
- 16 microstep resolutions of 400-51,200 via DIP switches, or 200-51,200 via software (increase by 200)
- 8 output current settings of 2.4-7.2A via DIP Switches, or 1.0-7.2A via software (increase by 0.1)
- Configurable control command smoothing for reducing motor vibration
- Idle current reduction to 50% or 90% selection via SW4
- Auto-tuning to match wide-range NEMA 23, 24, 34 and 42 stepper motors
- Anti-Resonance for optimal torque, extra smooth motion, low motor heating and noise
- Soft-start with no “jump” when powered on
- Optically isolated inputs with 5V or 24V
- Fault and Brake outputs
- Over-voltage and over-current protections

### 1.2 Applications

The RM72A stepper drive are designed to power 2 phase (1.8°) or 4-phase (0.9°) NEMA 23, 24, 34, and 42 hybrid stepper motors. It can be easily adopted in many industries (CNC, medical, automation, packaging...), such as X-Y tables, engraving machines, labeling machines, mills, plasma, laser cutters, pick and place devices, and so on. Its excellent performance, simple design, and easy setup make it ideal for many step & direction control type applications.

## 2. Specifications

### 2.1 Electrical Specifications

Parameters	RM72A			
	Min	Typical	Max	Unit
Output Current	2.4	-	7.2	A
Supply Voltage	18	20 - 70	80	VAC
	24	30 - 90	110	VDC
Logic signal current	7	10	16	mA
Pulse input frequency	0	-	200	kHz
Minimal Pulse Width	2.5	-	-	μS
Minimal Direction Setup	5.0	-	-	μS

Isolation resistance	500			MΩ
----------------------	-----	--	--	----

## 2.2 Environment

Cooling	Natural Cooling or Forced cooling			
Operating Environment	Environment	Avoid dust, oil fog and corrosive gases		
	Ambient Temperature	0°C — 65°C (32°F - 149°F)		
	Humidity	40%RH—90%RH		
	Operating Temperature	0°C — 50°C (32°F - 122°F)		
	Vibration	10-50Hz / 0.15mm		
Storage Temperature	-20°C — 65°C (-4°F - 149°F)			
Weight	Approx. 510g (1.13 lbs)			

## 2.3 Mechanical Specifications

(unit: mm [1inch=25.4mm])

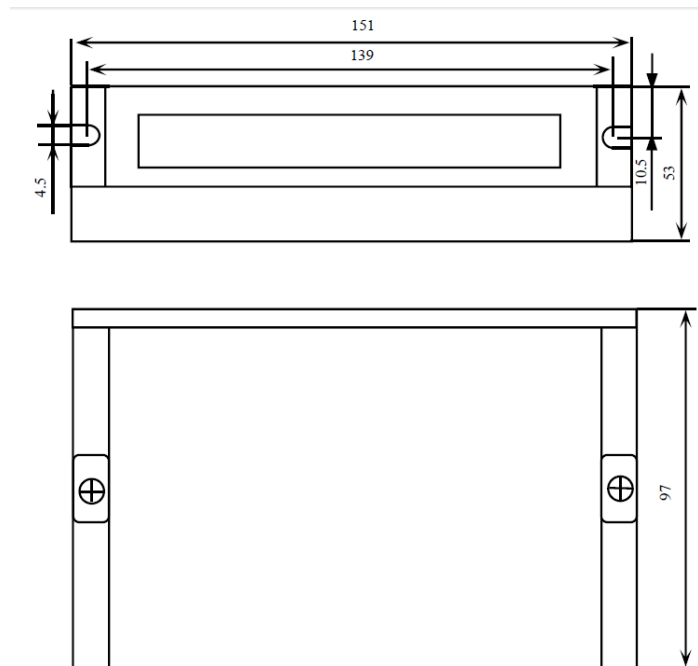

**Figure 1** Mechanical specifications

- **Side mounting recommended for better heat dissipation**

## 2.4 Elimination of Heat

- RM72A reliable working temperature should be < 60°C (140°F)
- It is recommended to use automatic idle-current mode to reduce motor heating. That means set the SW4 pin of DIP switch at “OFF” position.
- It is recommended to mount the drive vertically to maximize heat sink area. Use forced cooling method to cool if necessary.

### 3. Connection Pin Assignments and LED Indication

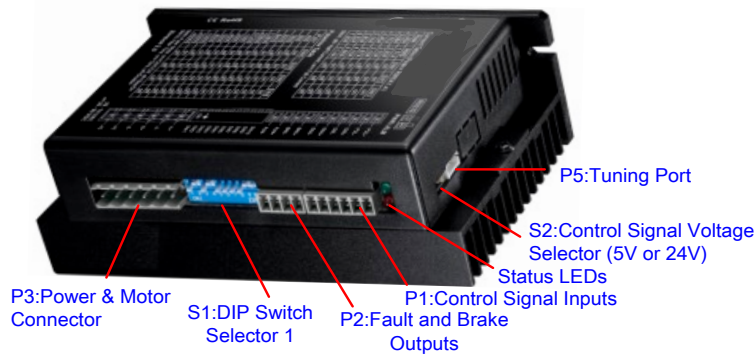

**Figure 2** Connectors, DIP switches, and LED locations

The RM72A has three connector blocks P1&P2&P3 (see above picture). P1 is for control signals connections, and P2 is for output signals connections, P3 is for power and motor connections. The following tables are brief descriptions of the three connectors. More detailed descriptions of the pins and related issues are presented in section 4, 5, 9.

#### 3.1 P1 - Control Connector

PIN	Details	
PUL+ (CW+)	<u>Pulse and Direction Connection:</u> (1) Optically isolated, high level 4.5-5V or 24V, low voltage 0-0.5V (2) Maximum 200 KHz input frequency (3) The width of PUL signal is at least 2.5 $\mu$ s, duty cycle is recommended 50% (4) Single pulse (step & direction) or double pulse (CW/CCW) is set by DIP Switch SW9 (5) DIR signal requires advance PUL signal minimum 5 $\mu$ s in single pulse mode (6) The factory setting of control signal voltage is 24V, <b>must need</b> to set S2 (figure 2) if it is 5V	
PUL- (CW-)		
DIR+ (CCW+)		
DIR- (CCW-)		
ENA+		<u>Enable Connection:</u> (default no connection) (1) Optically isolated, differential. (2) Disable the drive by 4.5- 24V input connection; enable the drive by 0-0.5V connection (3) ENA signal requires advance DIR signal minimum 5 $\mu$ s in single pulse mode (4) Enable time to be at least 200ms
ENA-		

#### Notes:

- (1) Shield cables are required for P1;
- (2) Don't tie P1/P2 cables and P3 cables together.

#### 3.2 P2 - Fault and Brake Output Connector

Pin	Details
BRK+	(1) Maximum 30V/100mA output (4) Brake connection refer to <a href="#">chapter 4.2</a>
BRK-	
ALM+	(1) Maximum 30V/100mA output

**ALM-**

- (2) Sinking or sourcing
- (3) The resistance between ALM+ and ALM- is low impedance as default, and will change to high when the drive goes into error protection.
- (4) Fault connection refer to [chapter 4.3](#)

**3.3 P3 - Motor and Power Supply Connector**

Pin Function	Details
A+, A-	Motor Phase A connections. Connect motor A+ wire to A+ Pin; motor A- wire to A-
B+, B-	Motor Phase B connections. Connect motor B+ wire to B+ Pin; motor B- wire to B-
AC	Power supply input 18-80VAC or 24-110 VDC(recommended 20-70VAC or 30-90VDC);
AC	No polarity



**Warning:** (1) Don't plug or unplug the P1 & P2&P3 terminal block to avoid drive damage or injury when RM72A is powered on. (2) If using an AC transformer, be sure to use a transformer with isolation. Otherwise there is a risk of electrocution

**3.4 P4 - Tuning Connector**

RM72A has a tuning port with RS232 to modify the drive parameters, it is just used to modify parameter, not for equipment control because neither precision nor stability is sufficient. If you need a field bus drive, use a RS485 or EtherCAT type drives:

The interface definition is as follows:

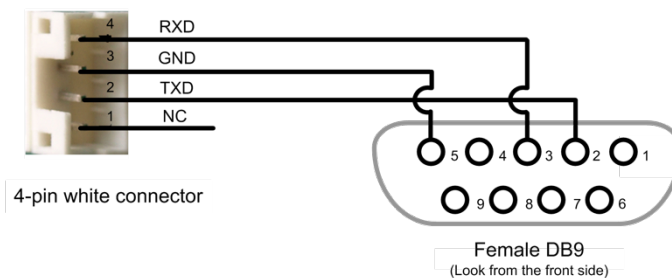

**Figure 3:** RS232 connector

**3.5 LED Light Indication**

There are two LED lights for RM72A. The GREEN one is the power indicator which will be always on generally. The RED one is a protection indicator which will flash 1-2 times in a 3-second period, when protection enabled for a RM72A. Different number of flashes indicates different protection type (read section 11 for detail).

## 4. Control Signal and Output Signal

### 4.1 Control Signal Connection

The RM72A can accept differential or single-ended control signals (pulse, direction, and enable) in open-collector or PNP connection through the P1 connector (figure 2). It is recommended to add an EMI line filter between the power supply and the drive to increase noise immunity for the drive in interference environments.

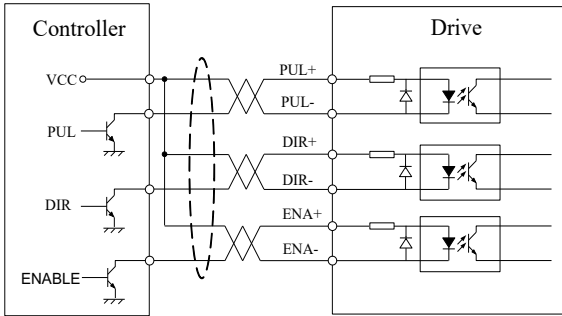

**Figure 4:** Connections to open-collector signal (common-anode)

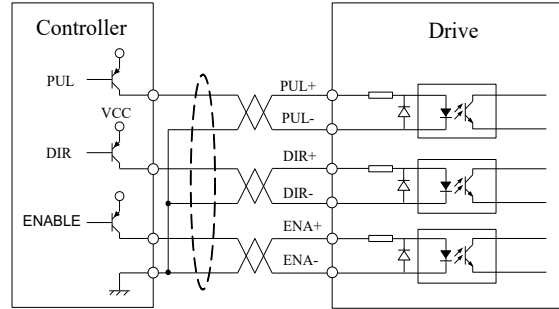

**Figure 5:** Connections to PNP signal (common-cathode)

**Notes:**

- (1) When "EAN" is switched on, the engine stops.
- (2) ENA signal is no-connected as default;
- (3) Control signal amplitude is 24 V as default. If it is 12 V, please set the S2 (Figure 2) selector switch to 5 V first, then connect 1KΩ resistor; If it is 5V, please set the S2 to 5V.

### 4.2 Fault and Brake Output Connection

- Fault Output

When over voltage or over current protection happens, RM72A red status LED light will blink and the impedance state between ALM+ and ALM- will change (from low to high or high to low depending on configuration) and can thus be detected. Fault output connection is optional, and it can be connected either in sinking or sourcing.

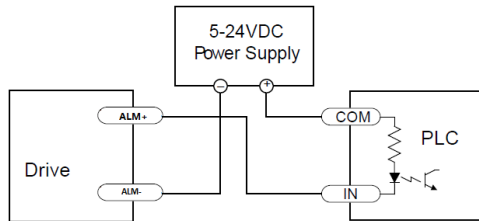

**Figure 6** Sinking output

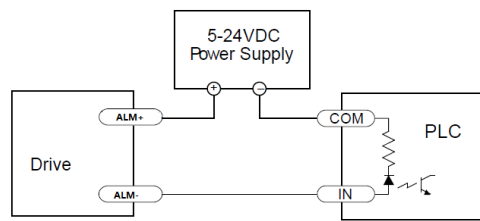

**Figure 7** Sourcing output

- Brake Control

It is recommended to connect a fly-wheel diode in parallel to a 24VDC relay and brake coil connection. Refer to the following figure for brake connection.

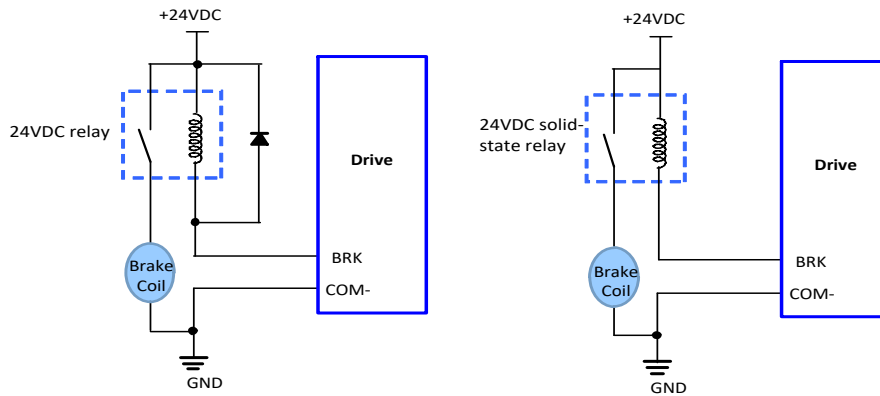

**Figure 8** Brake output

## 5. Motor Connection

The RM72A can drive 2-phase and 4-phase bipolar hybrid stepper motors with 4, 6, or 8 wires.

### 5.1 Connections of 4-lead Motor

The 4 lead motors are the least flexible and easy to connect. And the Speed – torque of motor depends on winding inductance. The output current from drive that is multiply the specified phase current by 1.4 to determine the peak output current.

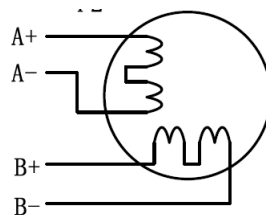

**Figure 9:** 4-lead Motor Connections

### 5.2 Connections of 6-lead Motor

Like 8 lead stepping motors, 6 lead motors have two configurations available for high speed or high torque operations. The higher speed configuration, or half coil, is described, because it uses one half of the motor’s inductor windings. The higher torque configuration, or full coil, uses the full coil windings.

#### 5.2.1 Half Coil Configuration

As previously stated, the half coil configuration uses 50% of the motor phase windings. This gives lower inductance, hence, lower torque output. Like the parallel connection of 8 lead motor, the torque output will be more stable at higher speeds. This configuration is also referred to as half chopper. In setting the drive output current multiply the specified per phase (or unipolar) current rating by 1.4 to determine the peak output current.

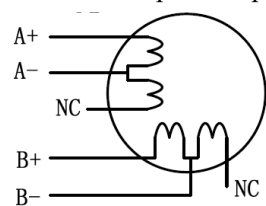



Figure 10: 6-lead motor half coil (higher speed) connections

### 5.2.2 Full Coil Configuration

The full coil configuration on a six lead motor should be used in applications where higher torque at lower speed is desired. This configuration is also referred to as full copper. In full coil mode, the motors should be run at only 70% of their rated current to prevent overheating.

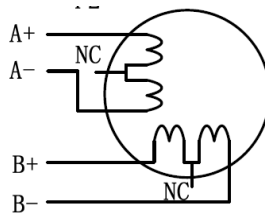

Figure 11: 6-lead motor full coil (higher torque) connections

## 5.3 Connections of 8-lead Motor

8 lead motors offer a high degree of flexibility to the system designer in that they may be connected in series or parallel, thus satisfying a wide range of applications.

### 5.3.1 Series Connection

A series motor configuration would typically be used in applications where a higher torque at lower speed is required. Because this configuration has the most inductance, the performance will start to degrade at higher speed. In series mode, the motors should also be run at only 70% of their rated current to prevent overheating.

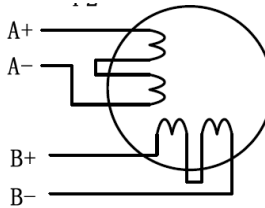

Figure 12: 8-lead motor series connections

### 5.3.2 Parallel Connection

An 8 lead motor in a parallel configuration offers a more stable, but lower torque at lower speeds. But because of the lower inductance, there will be higher torque at higher speeds. Multiply the per-phase (or unipolar) current rating by 1.96, or the bipolar current rating by 1.4, to determine the peak output current.

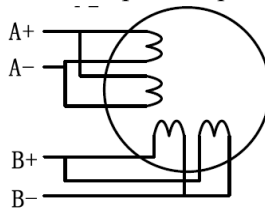

Figure 13: 8-lead motor parallel connections

## 6. Power Supply Selection

The RM72A can power medium and large size stepping motors (frame size from NEMA 23 to 42). To get good driving performances, it is important to select supply voltage and output current properly. Generally speaking, supply voltage determines the high speed performance of the motor, while output current determines the output torque of the driven motor (particularly at lower speed). Higher supply voltage will allow higher motor speed to be achieved, at the price of more noise and heating. If the motion speed requirement is low, it's better to use lower supply voltage to decrease noise, heating and improve reliability.

### 6.1 Regulated or Unregulated Power Supply

Both regulated and unregulated power supplies can be used to supply the drive. However, unregulated power supplies are preferred due to their ability to withstand current surge and fast response for current change. If you prefer to a regulated power supply, it is suggested to choose such a power supply specially designed for stepper/servo controls. Or, in the case when only normal switching power supplies are available, it is important to use "OVERSIZE" high current output rating power supplies (for example, using a 4A power supply for 3A stepper motor) to avoid problems such as current clamp. On the other hand, if unregulated supply is used, one may use a power supply of lower current rating than that of motor (typically 50%~70% of motor current). The reason is that the drive draws current from the power supply capacitor of the unregulated supply only during the ON duration of the PWM cycle, but not during the OFF duration. Therefore, the average current withdrawn from power supply is considerably less than motor current. For example, two 3A motors can be well supplied by one power supply of 4A rating.

### 6.2 Power Supply Sharing

Multiple RM72A drives can share one power supply to reduce cost, if that power supply has enough power capacity. To avoid cross interference, connect each stepper drive directly to the shared power supply separately. To avoid cross interference, DO NOT daisy-chain connect the power supply input pins of the Drivers. Instead connect them to power supply separately.

### 6.3 Selecting Supply Voltage

The RM72A is designed to operate within 18 - 80VAC or 24-110VDC voltage input. When selecting a power supply, besides voltage from the power supply power line voltage fluctuation and back EMF voltage generated during motor deceleration needs also to be taken into account. Please make sure leaving enough room for power line voltage fluctuation and back-EMF voltage charge back.

Higher supply voltage can increase motor torque at higher speeds, thus helpful for avoiding losing steps. However, higher voltage may cause bigger motor vibration at lower speed, and it may also cause over-voltage protection or even drive damage. Therefore, it is suggested to choose only sufficiently high supply voltage for intended applications.

## 7. DIP Switch Configurations

The RM72A has one 10-bit DIP switch and one 1-bit selector. The first 10-bit is used to configure settings of micro step resolution, output current, motor standstill current, pulse type and smoothing time as shown below.

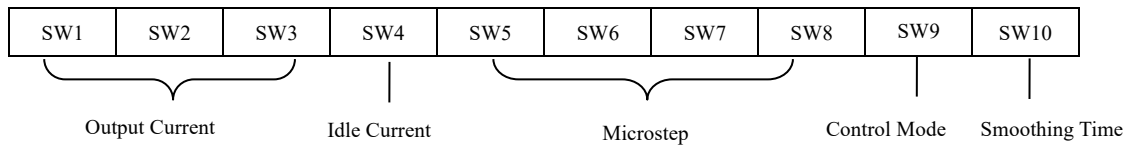

The second 1-bit selector is located on the top (S2 in figure 2), used to configure the voltage of control signals. For the safety of optically coupled, the factory setting is 24V, which no need to connect 2K resistors like the old drives, making it easier to use. When the voltage of the control signal is 5V, the S2 must be set to 5V, otherwise, [the motor won't work](#).

### 7.1 Microstep Resolution Configurations

Microstep resolution is set by SW5, 6, 7, 8 of the DIP switches as shown in the following table

Microstep	Steps/rev.(for 1.8°motor)	SW5	SW6	SW7	SW8
2	400(default)	ON	ON	ON	ON
4	800	OFF	ON	ON	ON
8	1600	ON	OFF	ON	ON
16	3200	OFF	OFF	ON	ON
32	6400	ON	ON	OFF	ON
64	12800	OFF	ON	OFF	ON
128	25600	ON	OFF	OFF	ON
256	51200	OFF	OFF	OFF	ON
5	1000	ON	ON	ON	OFF
10	2000	OFF	ON	ON	OFF
20	4000	ON	OFF	ON	OFF
25	5000	OFF	OFF	ON	OFF
40	8000	ON	ON	OFF	OFF
50	10000	OFF	ON	OFF	OFF
100	20000	ON	OFF	OFF	OFF
200	40000	OFF	OFF	OFF	OFF

### 7.2 Output Current Configurations

For a given motor, higher drive current will make the motor to output more torque, but at the same time causes more heating in the motor and drive. Therefore, output current is generally set to be such that the motor will not overheat for long time operation. Since parallel and serial connections of motor coils will significantly change resulting inductance and resistance, it is therefore important to set drive output current depending on motor phase current, motor leads and connection methods. Phase current rating supplied by motor manufacturer is important in selecting drive current, however the selection also depends on leads and connections.

The first three bits (SW1, 2, 3) of the DIP switch are used to set the dynamic current. Select a setting closest to your motor's required current.

### 7.2.1 Dynamic Current Configurations

Peak Current	RMS Current	SW1	SW2	SW3
2.40A(default)	1.70A	ON	ON	ON
3.08A	2.18A	OFF	ON	ON
3.77A	2.67A	ON	OFF	ON
4.45A	3.15A	OFF	OFF	ON
5.14A	3.64A	ON	ON	OFF
5.83A	4.12A	OFF	ON	OFF
6.52A	4.61A	ON	OFF	OFF
7.20A	5.09A	OFF	OFF	OFF

**Notes:** Due to motor inductance, the actual current in the coil may be smaller than the dynamic current setting, particularly under high speed condition.

### 7.2.2 Idle Current Configuration

SW4 is used to set motor idle current percentage. At OFF position it means the standstill current is set to be 50% of the selected output current. At ON position it means standstill current is set to be 90%.

The current automatically reduced to 50% of the selected dynamic current 0.4 second after the last pulse.

### 7.3 Control Mode Configurations

DIP switch SW9 is used to configure the control mode. Factory setting is single pulse (step & direction, or pulse & direction) control. Setting to ON to change the control model to double pulse (CW/CCW) control type.

### 7.4 Smoothing Time Configuration

RM72A has an advanced feature called control command smoothing to make the input pulse from pulse generator (controller, PLC, etc.) S-curve acceleration, to improve motion smoothness and high-speed start frequency in many circumstances. This is achieved through adding filtering time which is configured SW10. Setting to ON to activate the feature with 12ms acceleration time.

### 7.3 Automatic Motor Matching & Self Configuration

When powered on a RM72A will automatically configure itself with the best settings to match the driven stepper motor for optimal performance. No action is needed.

## 8. Wiring Notes

- In order to improve anti-interference performance of the drive, it is recommended to use twisted pair shield cable.
- To prevent noise incurred in PUL/DIR signal, pulse/direction signal wires and motor wires should not be tied up together. It is better to separate them by at least 10 cm, otherwise the disturbing signals generated by motor will easily disturb pulse direction signals, causing motor position error, system instability and other failures.
- If only one power supply serves multiple RM72A drives, separately connecting the drives to the power supply is recommended instead of daisy-chaining.
- It is prohibited to pull and plug connector P2 while the drive is powered ON, because there is high current flowing through motor coils (even when motor is at standstill). Pulling or plugging connector P2 with power on will cause extremely high back-EMF voltage surge, which may damage the drive.

## 9. Typical Connection

A complete stepping system should include stepping motor, stepping drive, power supply and controller (pulse generator). A typical connection is shown as below.

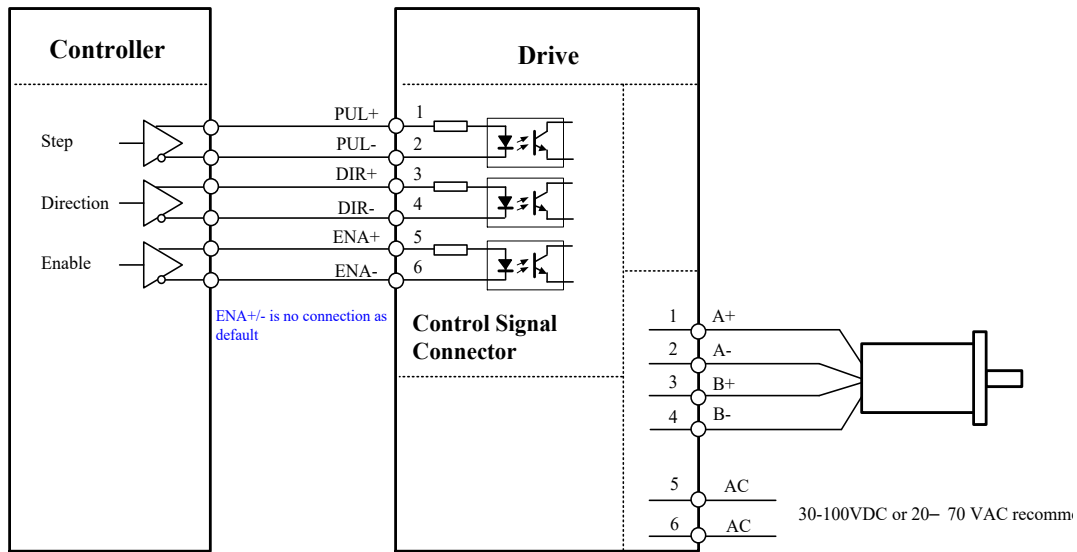

Figure 14: Typical connection

## 10. Sequence Chart of Control Signals

In order to avoid some fault operations and deviations, PUL, DIR and ENA should abide by some rules, shown as following diagram:

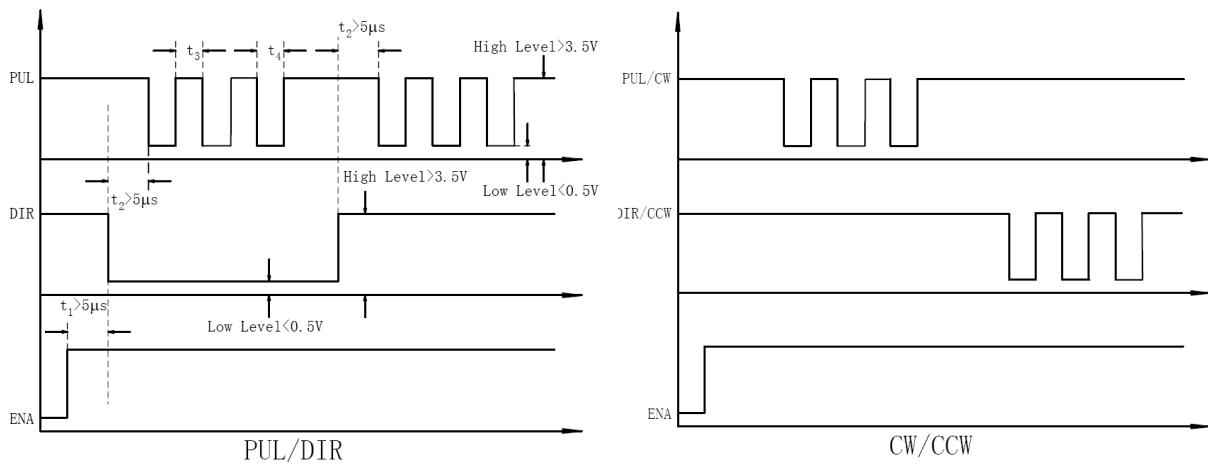

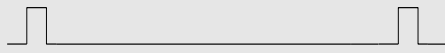

Figure 15: Sequence chart of control signals

### Remark:

- $t_1$ : ENA must be ahead of DIR by at least 5ms. Usually, ENA+ and ENA- are NC (not connected). See “Connector P1 Configurations” for more information.
- $t_2$ : DIR must be ahead of PUL effective edge by  $5\mu\text{s}$  to ensure correct direction;
- $t_3$ : Pulse width not less than  $2.5\mu\text{s}$ ;
- $t_4$ : Low level width not less than  $2.5\mu\text{s}$ .

## 11. Protection Functions

To improve reliability, the drive incorporates some built-in protections features.

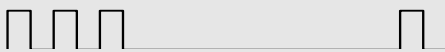
Priority	Time(s) of Blink	Sequence wave of red LED	Description
1st	1		Over-current protection activated when peak current exceeds the limit.
2nd	2		Over-voltage protection activated when drive working voltage is greater than 160VDC
3rd	3		Reserved.

When above protections are active, the motor shaft will be free or the red LED blinks. Reset the drive by repowering it to make it function properly after removing above problems.

## 12. Troubleshooting

In the event that your drive doesn't operate properly, the first step is to identify whether the problem is electrical or mechanical in nature. The next step is to isolate the system component that is causing the problem. As part of this process you may have to disconnect the individual components that make up your system and verify that they operate independently. It is important to document each step in the troubleshooting process. You may need this documentation to refer back to at a later date, and these details will greatly assist our Technical Support staff in determining the problem should you need assistance.

Many of the problems that affect motion control systems can be traced to electrical noise, controller software errors, or mistake in wiring.

### Problem Symptoms and Possible Causes

Symptoms	Possible Problems
<b>Motor is not rotating</b>	No power
	Microstep resolution setting is wrong
	DIP switch current setting is wrong
	Fault condition exists
	The drive is disabled
<b>Motor rotates in the wrong direction</b>	Motor phases may be connected in reverse
<b>The drive in fault</b>	DIP switch current setting is wrong
	Something wrong with motor coil
<b>Erratic motor motion</b>	Control signal is too weak
	Control signal is interfered
	Wrong motor connection
	Something wrong with motor coil
	Current setting is too small, losing steps
<b>Motor stalls during acceleration</b>	Current setting is too small
	Motor is undersized for the application
	Acceleration is set too high
	Power supply voltage too low
<b>Excessive motor and drive heating</b>	Inadequate heat sinking / cooling
	Automatic current reduction function not being utilized
	Current is set too high

## **13. Warranty**

### **Twelve Month Warranty**

#### **Exclusions**

The above warranty does not extend to any product damaged by reasons of improper or inadequate handlings by customer, improper or inadequate customer wirings, unauthorized modification or misuse, or operation beyond the electrical specifications of the product and/or operation beyond environmental specifications for the product.

#### **Obtaining Warranty Service**

To obtain warranty service, please contact your seller to obtain a returned material authorization number (RMA) before returning product for service.