

Ezi-IO[®]

Input/Output Module

- EtherCAT Based Analog Output Module
- All EtherCAT Synchronization Modes Supported
- CiA 401 Profile Supported
- Simple and Easy Wiring
- Output Range Configurable
- Calibration for Output Deviation

EtherCAT[®]

DA

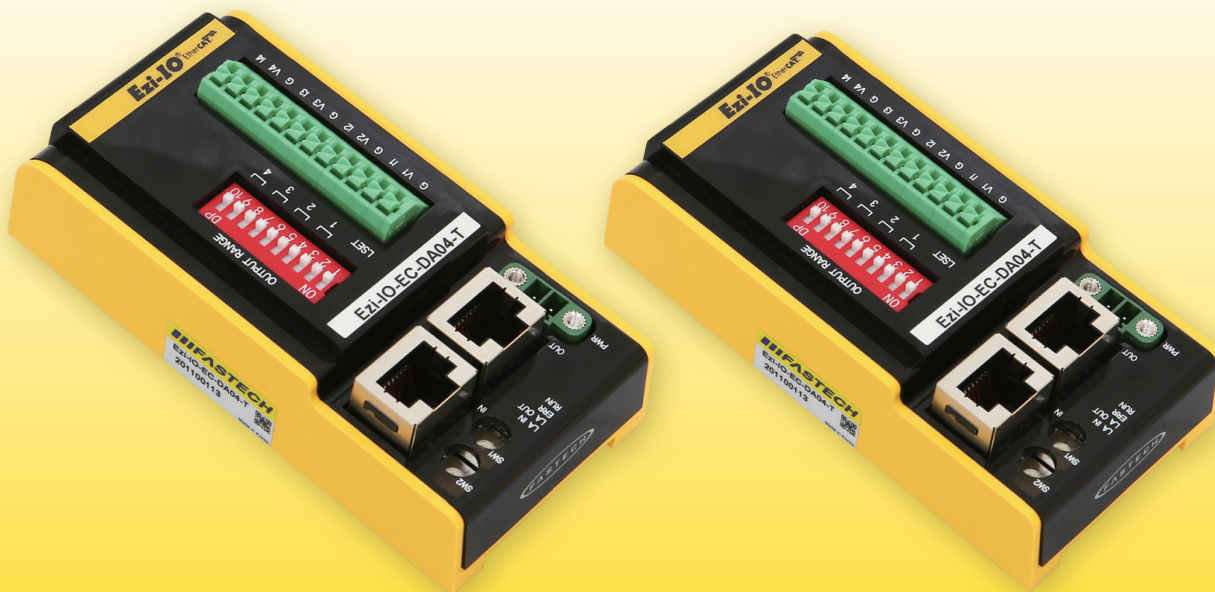

CE

FASTTECH

Fast, Accurate, Smooth Motion

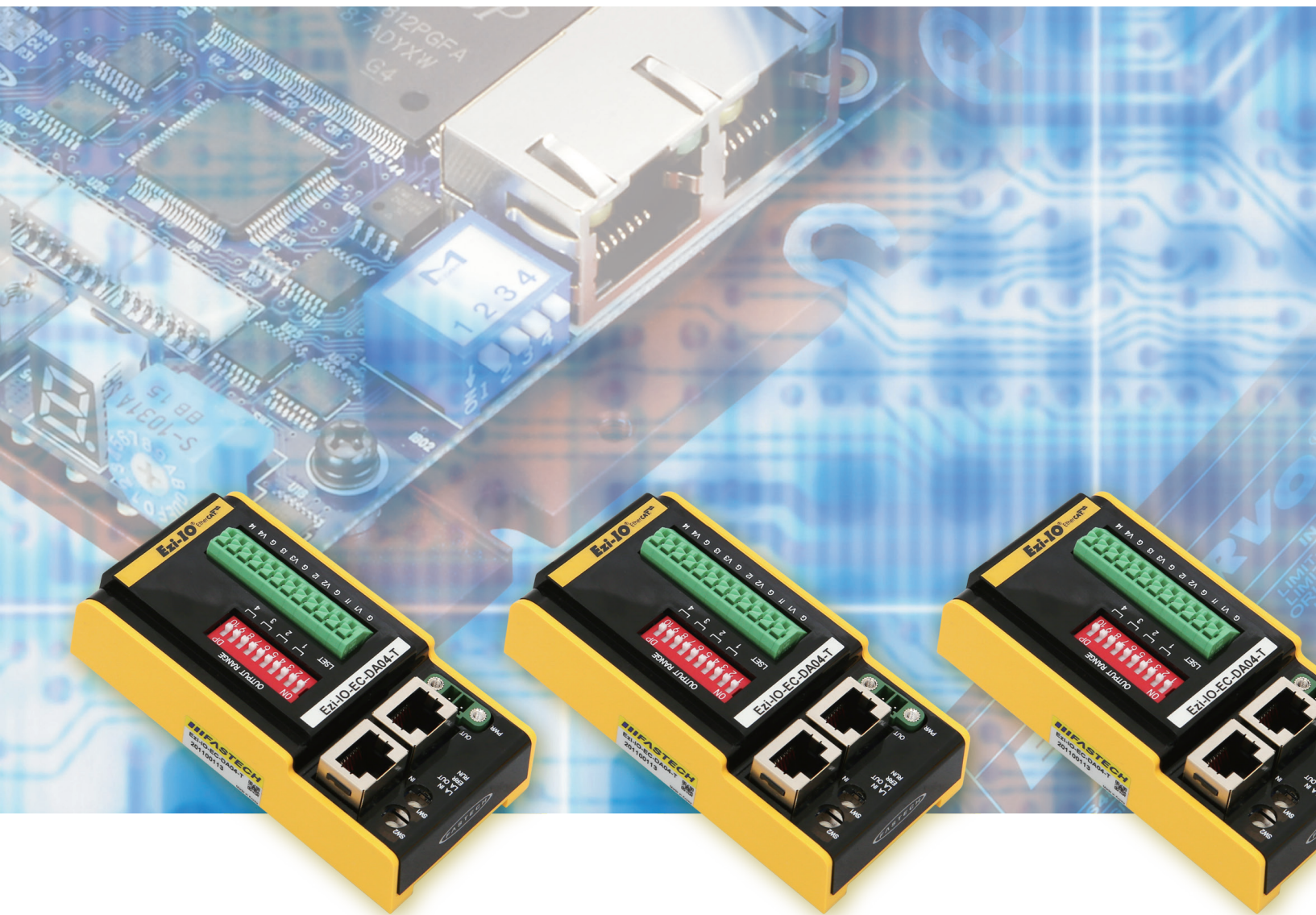

Fast, Accurate, Smooth Motion

Ezi-IO[®]
Input/Output Module

EtherCAT[®]
DA



1 EtherCAT Based Analog Output Module

Ezi-IO EtherCAT DA is an analog output module which supports EtherCAT, a fieldbus based on high speed Ethernet (100Mbps, Full-Duplex).

Ezi-IO EtherCAT DA is an EtherCAT Slave module which supports CoE(CAN Application layer over EtherCAT). It supports CiA 401 profile, and can be connected to the EtherCAT master without topology limitation.

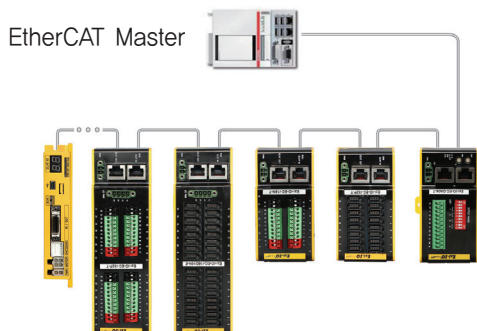

2 Simple and Easy Wiring

Ezi-IO EtherCAT DA uses a push-in type terminal block. The push-in type terminal block can be easily connected to various devices using ferrule terminals, making the wiring much simpler and easier.

3 EtherCAT Synchronization Modes

Ezi-IO EtherCAT DA supports all EtherCAT synchronization modes. You can select from Free Run, SM Event, DC SYNC Event synchronization mode according to the purpose of use.

4 Easy Setup with Switches

Ezi-IO EtherCAT DA can easily set EtherCAT ID with rotary switches and identify EtherCAT address easily. In addition, the output signal range can be easily set with the DIP switches.

5 Calibration for Output Deviation

Ezi-IO EtherCAT DA provides an output deviation calibration function as a countermeasure against deviations in the output signal due to the type of connection device, the characteristics of the cable, and the difference in the connection method.

● Ezi-IO EtherCAT DA Part Numbering

● Ezi-IO EtherCAT DA Part Number

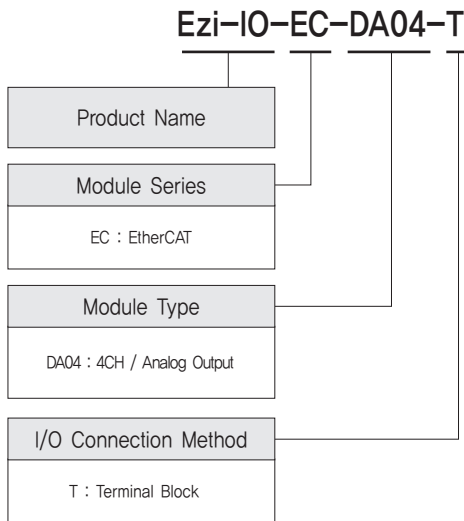

Part Number

Ezi-IO-EC-DA04-T

● Specifications of Module

Model		Ezi-IO-EC-DA04-T		
Output Mode		Voltage Output	Current Output	
Input Voltage		DC24V±10%		
Current Consumption		Max. 180mA		
Operation Condition	Ambient Temperature	<ul style="list-style-type: none"> · In Use: 0~50°C · In Storage: -20~70°C 		
	Humidity	<ul style="list-style-type: none"> · In Use: 35~85% RH (Non-Condensing) · In Storage: 10~90% RH (Non-Condensing) 		
	Vib. Resist.	0.5g		
Function	Number of Output Channels	4CH		
	Output Range	<ul style="list-style-type: none"> · 0~5V · 1~5V · 0~10V · -10~10V 	<ul style="list-style-type: none"> · 0~20mA · 4~20mA 	
	Output Range Setting Method	<ul style="list-style-type: none"> · SDO Communications (Separate settings for CH1~4) · DIP Switch (Separate settings for CH1~4) 		
	External Load Resistance	1kΩ or higher	400Ω or lower	
	Max. Resolution	1/50,000 (Full Scale)		
	Accuracy	25°C	±0.3% (Full Scale)	
		0~50°C	±0.4% (Full Scale)	
	Analog Conversion Cycle	500μs/4CH		
	D/A Converted Data	<ul style="list-style-type: none"> · -25,000~25,000 (-10~10V output range) · 0~25,000 (Other output ranges except -10~10V) 	0~25,000	
Isolation Method	Between analog output and communication connections : Digital isolation (Between channels : Non-isolated)			
LED Display		<ul style="list-style-type: none"> · Power Status (PWR) · EtherCAT Status (RUN) · Operation Error (ERR) · EtherCAT Connection (LA IN, LA OUT) 		
EtherCAT	Protocol	CoE (CiA 401 I/O Profile), FoE (Firmware Download)		
	Synchronization	Free Run, SM Event, DC SYNC Event		
	Bus Interface	2×RJ45 Connector		
	Cable	STP (Shielded Twisted Pair) Cable, Category 5e or higher / Max. 100m		

● Dimensions of Module [mm]

◆ Ezi-IO-EC-DA04-T

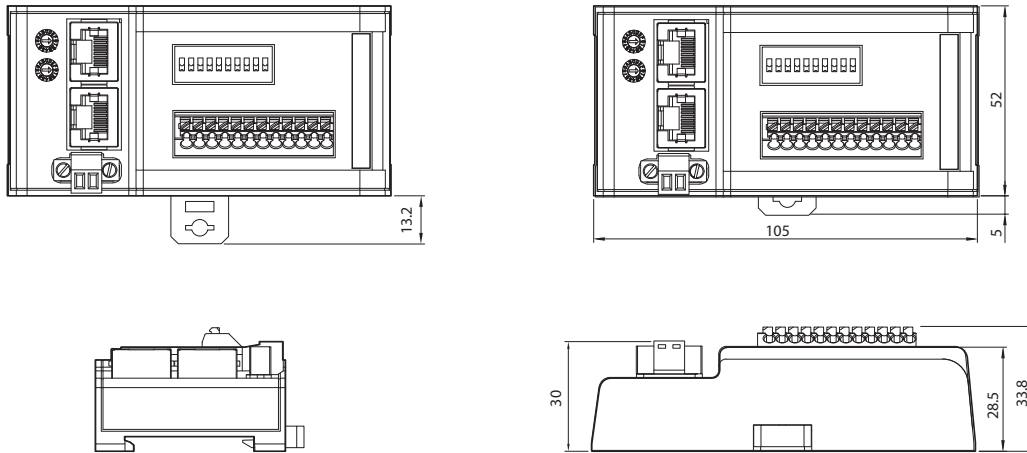

* Install the product on a din rail with a width of 35 mm.

● Settings and Operation [Ezi-IO-EC-DA04-T]

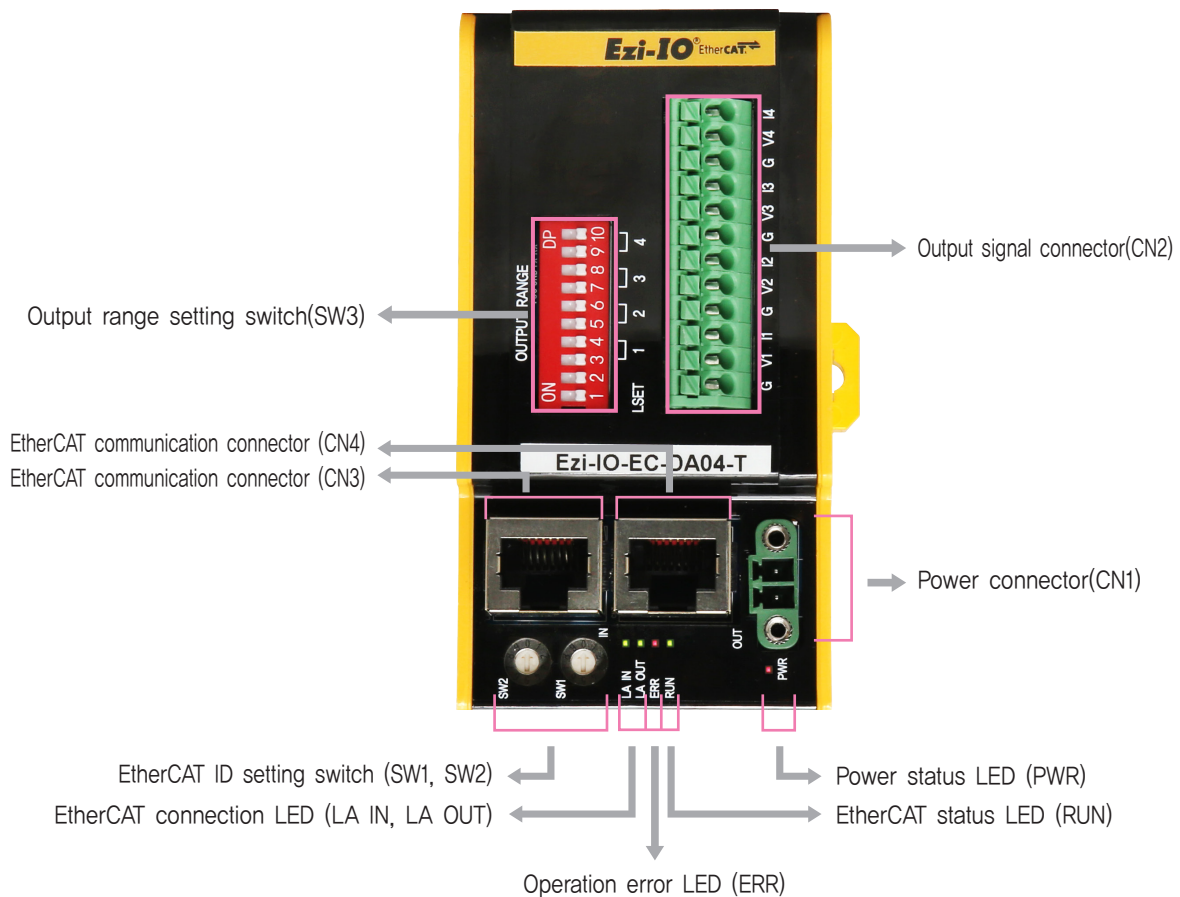

1. EtherCAT ID Setting Switch (SW1, SW2)

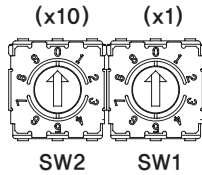

They are switches to set the EtherCAT ID (ECAT Device ID) node address, and they represent a decimal number.

SW1 indicates the units digit ($\times 1$), and SW2 indicates the tens digit ($\times 10$).

2. Output Range Setting Switch(SW3)

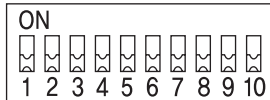

SW3 is a switch for setting the output range. You can set the range with the combination of the switches.

● Selecting Output Setting Method

You can select the output setting method with the LSET (SW3,1) switch as follows.

Setting Method	Switch	Description
	LSET SW3,1	
DIP Switch	ON	Setting output range with DIP switches (SW3,3~SW3,10)
SDO Communication	OFF	Setting output range with EtherCAT SDO communication

* Set SW3,1 before supplying power to the module.

* SW3,2 is not used.

● Output Range Setting

When using the DIP Switch for setting (SW3,1 = ON), the output range is set as shown in the table below.

Output Range	Switch	CH1		CH2		CH3		CH4	
		SW3,3	SW3,4	SW3,5	SW3,6	SW3,7	SW3,8	SW3,9	SW3,10
0~5V		OFF	OFF	OFF	OFF	OFF	OFF	OFF	OFF
-10~10V		OFF	ON	OFF	ON	OFF	ON	OFF	ON
0~20mA		ON	OFF	ON	OFF	ON	OFF	ON	OFF
4~20mA		ON	ON	ON	ON	ON	ON	ON	ON

* Output range of 1~5V and 0~10V can only be set by SDO communication.

3. Status LED

● Power Status LED

Name	Color	Status	Description
PWR	Red	OFF	Power is OFF
		ON	Power is ON

● EtherCAT Status LED

Name	Color	Status	Description
RUN	Green	OFF	State INIT or Power OFF
		Blinking	State PRE-OPERATIONAL
		Single Flash	State SAFE-OPERATIONAL
		ON	State OPERATIONAL
		Flickering	State BOOTSTRAP

• Operation Error LED

Name	Color	Status	Description
ERR	Red	OFF	No Error or Power OFF
		Blinking	Invalid Configuration
		Single Flash	Local Error
		Double Flash	Watchdog Time Out

• EtherCAT Connection LED

Name	Color	Status	Description
LA IN / LA OUT	Green	OFF	Link not Established
		ON	Link Established
		Flickering	Link Established and in Operation

4. Power Connector (CN1)

No.	Function	I/O
1	DC24V	Input
2	GND	Input

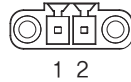

5. Output Signal Connector(CN2)

No.	Name	Function	I/O
1	G	Analog GND	Output
2	V1	Voltage Out 1	Output
3	I1	Current Out 1	Output
4	G	Analog GND	Output
5	V2	Voltage Out 2	Output
6	I2	Current Out 2	Output
7	G	Analog GND	Output
8	V3	Voltage Out 3	Output
9	I3	Current Out 3	Output
10	G	Analog GND	Output
11	V4	Voltage Out 4	Output
12	I4	Current Out 4	Output

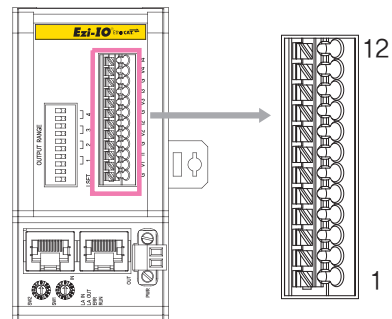

6. EtherCAT Communication Connector (CN3, CN4)

No.	Function
1	TD+
2	TD-
3	RD+
4	----
5	----
6	RD-
7	----
8	----
Connector hood	F,GND

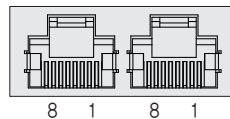

● System Configuration [Ezi-IO-EC-DA04-T]

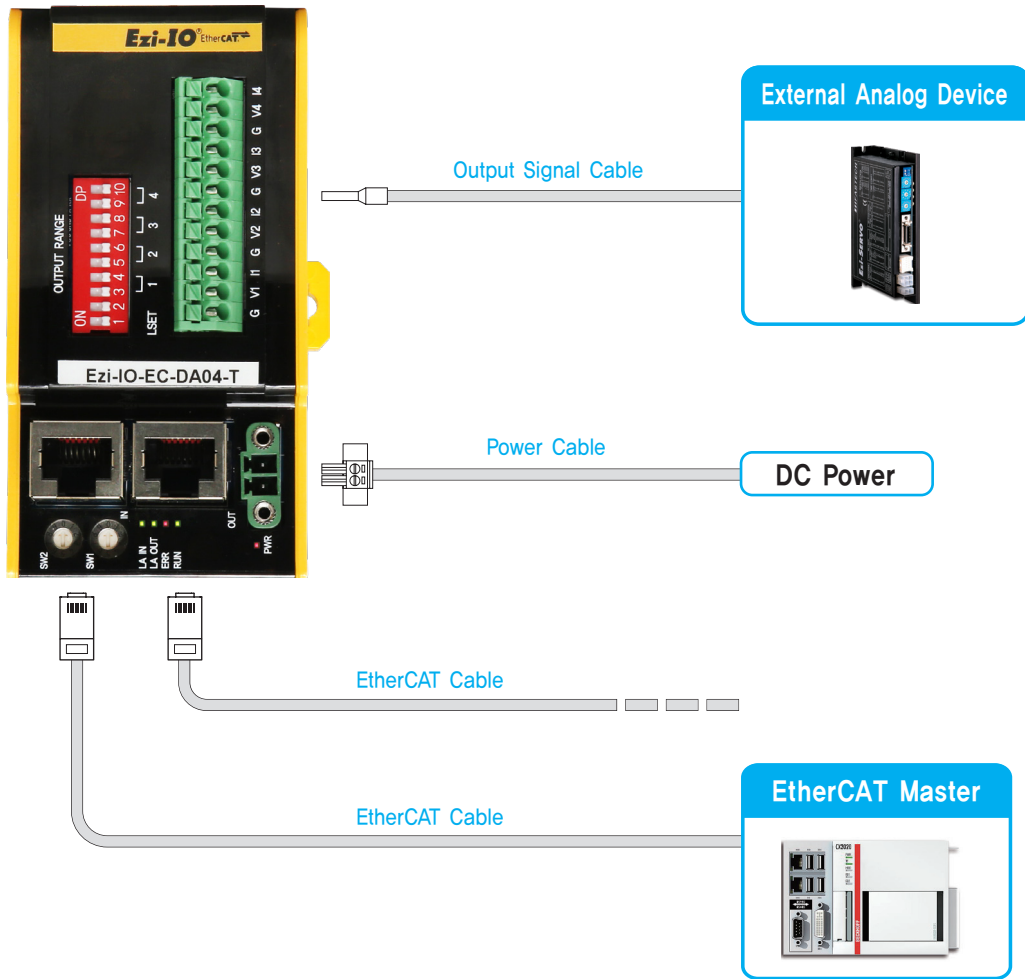

FASTECH Ezi-IO EtherCAT DA

1. Accessories

● Connectors

Purpose	Item	Part Number	Manufacturer
Power (CN1)	Terminal Block	MC421-38102	DECA

※ The connectors above are supplied with the product. If you are using other parts, please make sure they meet the specifications.

2. Options

● EtherCAT Cable

Purpose	Part Number	Length [m]	Remarks
EtherCAT Connection (CN3, CN4)	CGNR-EC-001F	1	· STP(Shielded Twisted Pair) Cable · Category 5e or higher · Maximum Length: 100m · Normal Cable
	CGNR-EC-002F	2	
	CGNR-EC-003F	3	
	CGNR-EC-005F	5	

※ If you need cables with length(in units of 1m) not listed on the table or robot cables, please contact FASTECH for more information.

External Wiring Diagram [Ezi-IO-EC-DA04-T]

1 Voltage Output Mode

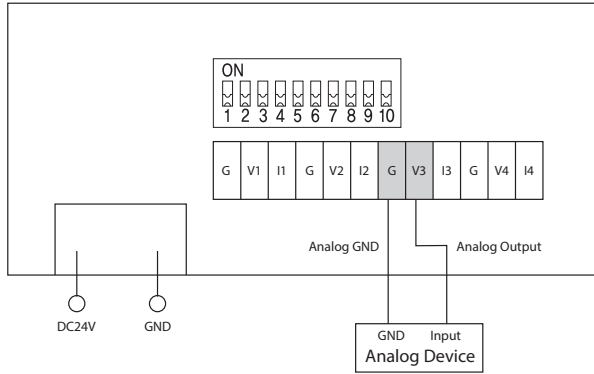

2 Current Output Mode

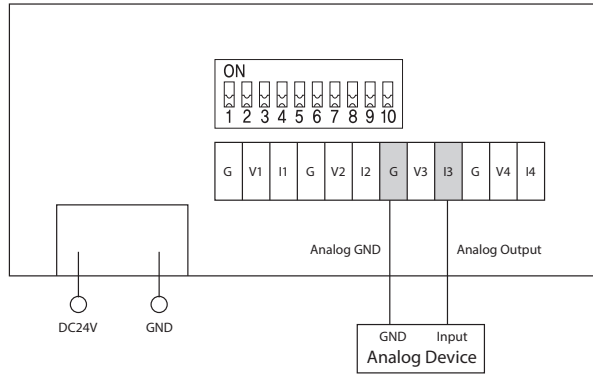

MEMO

MEMO



Fast, Accurate, Smooth Motion

FASTECH Co., Ltd.

Rm#1202, 401-dong, Bucheon Techno-Park,
655, Pyeongcheon-ro, Bucheon-si Gyeonggi-do,
Republic of Korea (Postal Code: 14502)
TEL : +82-32-234-6317 FAX : +82-32-234-6302
E-mail : sales@fastech-motions.com
Homepage : www.fastech-motions.com